

# FM201L THRU FM207L

## SURFACE MOUNT GLASS PASSIVATED SILICON RECTIFIER VOLTAGE RANGE 50 to 1000 Volts CURRENT 2.0 Ampere

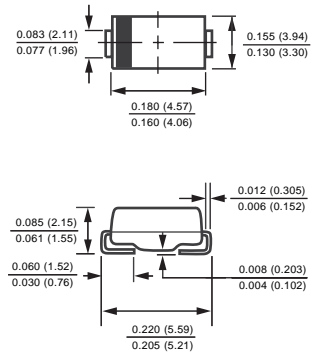
### FEATURES

- \* Glass passivated device
- \* Ideal for surface mounted applications
- \* Low leakage current
- \* Metallurgically bonded construction
- \* Mounting position: Any
- \* Weight: 0.098 gram

### MECHANICAL DATA

- \* Epoxy : Device has UL flammability classification 94V-0

SMBL



### MAXIMUM RATINGS AND ELECTRICAL CHARACTERISTICS

Ratings at 25 °C ambient temperature unless otherwise specified.  
Single phase, half wave, 60 Hz, resistive or inductive load.  
For capacitive load, derate current by 20%.

#### MAXIMUM RATINGS (@ TA=25 °C unless otherwise noted)

RATINGS	SYMBOL	FM201L	FM202L	FM203L	FM204L	FM205L	FM206L	FM207L	UNITS
Maximum Recurrent Peak Reverse Voltage	$V_{RRM}$	50	100	200	400	600	800	1000	Volts
Maximum RMS Voltage	$V_{RMS}$	35	70	140	280	420	560	700	Volts
Maximum DC Blocking Voltage	$V_{DC}$	50	100	200	400	600	800	1000	Volts
Maximum Average Forward Rectified Current at Ambient Temperature	$I_O$	2.0							Amps
Peak Forward Surge Current 8.3 ms single half sine-wave superimposed on rated load (JEDEC method)	$I_{FSM}$	50							Amps
Typical Current Squared Time	$I^2T$	10.3							A <sup>2</sup> S
Typical Thermal Resistance (Note 1)	$R_{\theta JA}$	53							°C/W
Typical Thermal Resistance (Note 1)	$R_{\theta JL}$	16							°C/W
Typical Junction Capacitance (Note 2)	$C_J$	30							pF
Operating Temperature Range	$T_J$	150							°C
Storage Temperature Range	$T_{STG}$	-55 to + 150							°C

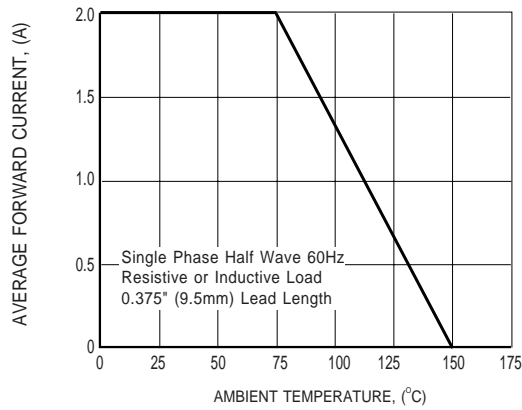
#### ELECTRICAL CHARACTERISTICS (@TA=25 °C unless otherwise noted)

CHARACTERISTICS	SYMBOL	FM201L	FM202L	FM203L	FM204L	FM205L	FM206L	FM207L	UNITS
Maximum Instantaneous Forward Voltage at 2.0A DC	$V_F$	1.1							Volts
Maximum Average Reverse Current	$I_R$	5.0							μA
at Rated DC Blocking Voltage		125							μA

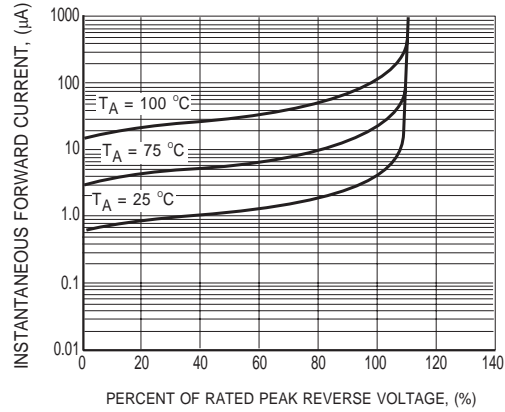
- NOTES : 1. Thermal Resistance :Mounted on PCB.  
2. Measured at 1 MHz and applied reverse voltage of 4.0 volts.  
3. "Fully ROHS compliant", "100% Sn plating (Pb-free)".  
4. Available in Halogen-free epoxy by adding suffix -HF after the part nbr.

2010-05  
REV: O

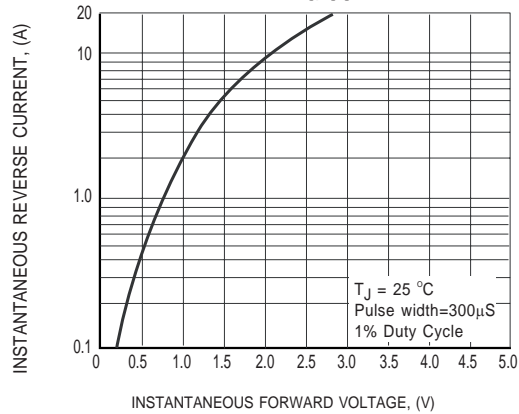
# RATING AND CHARACTERISTICS CURVES ( FM201L THRU FM207L )



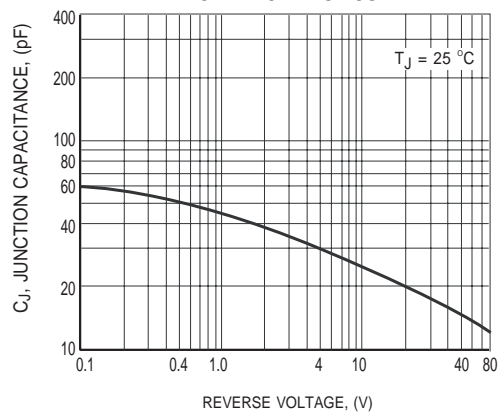
**FIG.1 TYPICAL FORWARD CURRENT DERATING CURVE**



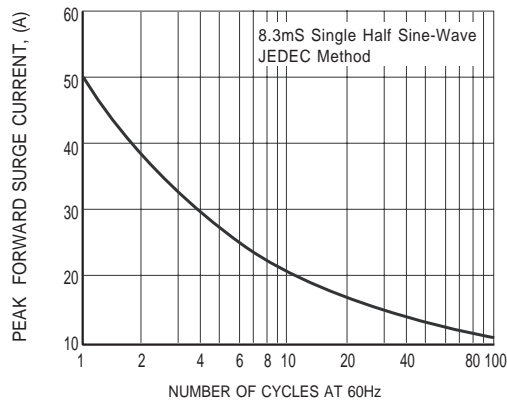
**FIG.2 TYPICAL REVERSE CHARACTERISTICS**



**FIG.3 TYPICAL INSTANTANEOUS FORWARD CHARACTERISTICS**

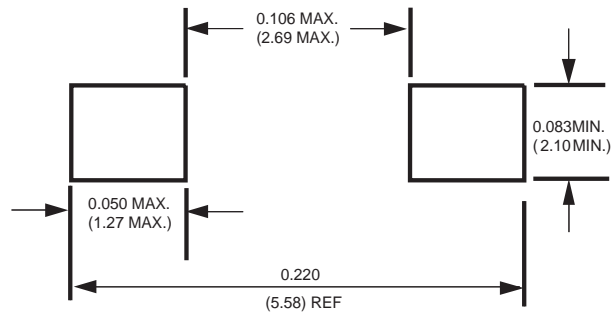


**FIG.4 TYPICAL JUNCTION CAPACITANCE**



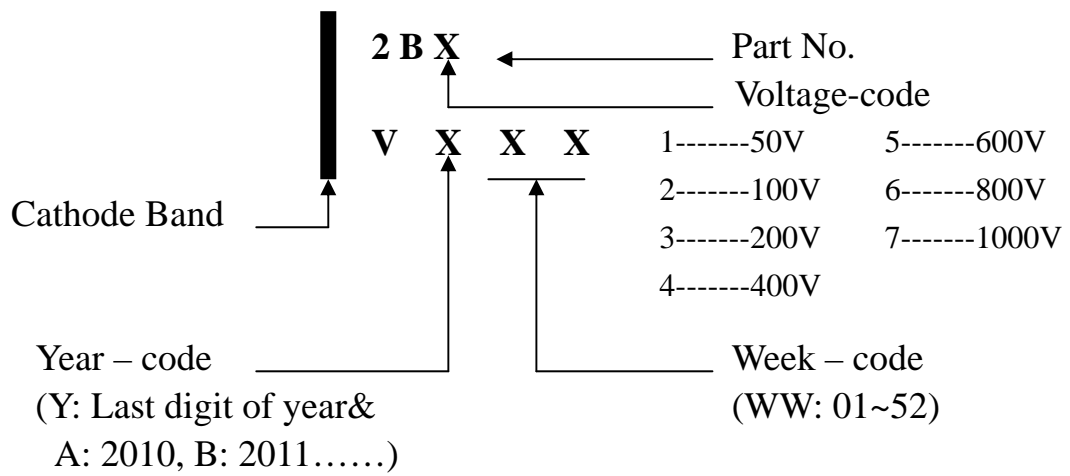
**FIG.5 MAXIMUM NON-REPETITIVE FORWARD SURGE CURRENT**

## Mounting Pad Layout



Dimensions in inches and (millimeters)

## Marking Description



## PACKAGING OF DIODE AND BRIDGE RECTIFIERS

### REEL PACK

PACKAGE	PACKING CODE	EA PER REEL	COMPONENT SPACE(mm)	TAPE SPACE (mm)	REEL DIA (mm)	CARTON SIZE (mm)	EA PER CARTON	GROSS WEIGHT(Kg)
SMBL	-T	500	---	---	178	390*205*310	16,000	---
SMBL	-W	3,000	---	---	330	355*360*350	48,000	13.90

## DISCLAIMER NOTICE

Rectron Inc reserves the right to make changes without notice to any product specification herein, to make corrections, modifications, enhancements or other changes. Rectron Inc or anyone on its behalf assumes no responsibility or liability for any errors or inaccuracies. Data sheet specifications and its information contained are intended to provide a product description only. "Typical" parameters which may be included on RECTRON data sheets and/ or specifications can and do vary in different applications and actual performance may vary over time. Rectron Inc does not assume any liability arising out of the application or use of any product or circuit.

Rectron products are not designed, intended or authorized for use in medical, life-saving implant or other applications intended for life-sustaining or other related applications where a failure or malfunction of component or circuitry may directly or indirectly cause injury or threaten a life without expressed written approval of Rectron Inc. Customers using or selling Rectron components for use in such applications do so at their own risk and shall agree to fully indemnify Rectron Inc and its subsidiaries harmless against all claims, damages and expenditures.

