



Dual 8-Bit, 40MSPs, 3V, Low-Power ADC with Internal Reference and Multiplexed Parallel Outputs

General Description

The MAX1196 is a 3V, dual 8-bit analog-to-digital converter (ADC) featuring fully differential wideband track-and-hold (T/H) inputs, driving two ADCs. The MAX1196 is optimized for low power, small size, and high-dynamic performance for applications in imaging, instrumentation, and digital communications. This ADC operates from a single 2.7V to 3.6V supply, consuming only 87mW while delivering a typical signal-to-noise and distortion (SINAD) of 48.4dB at an input frequency of 20MHz and a sampling rate of 40MSPs. The T/H driven input stages incorporate 400MHz (-3dB) input amplifiers. The converters can also be operated with single-ended inputs. In addition to low operating power, the MAX1196 features a 3mA sleep mode as well as a 0.1µA power-down mode to conserve power during idle periods.

An internal 2.048V precision bandgap reference sets the full-scale range of the ADC. A flexible reference structure allows the use of this internal or an externally applied reference, if desired for applications requiring increased accuracy or a different input voltage range.

The MAX1196 features parallel, multiplexed, CMOS-compatible three-state outputs. The digital output format can be set to two's complement or straight offset binary through a single control pin. The device provides for a separate output power supply of 1.7V to 3.6V for flexible interfacing. The MAX1196 is available in a 7mm × 7mm, 48-pin TQFP package, and is specified for the extended industrial (-40°C to +85°C) temperature range.

Pin-compatible, nonmultiplexed higher speed versions of the MAX1196 are also available. Refer to the MAX1198 data sheet for 100MSPs, the MAX1197 data sheet for 60MSPs, and the MAX1195 data sheet for 40MSPs.

For a 10-bit, pin-compatible upgrade, refer to the MAX1186 data sheet. With the N.C. pins of the MAX1196 internally pulled down to ground, this ADC becomes a drop-in replacement for the MAX1186.

Applications

- Baseband I/Q Sampling
- Multichannel IF Sampling
- Ultrasound and Medical Imaging
- Battery-Powered Instrumentation
- WLAN, WWAN, WLL, MMDS Modems
- Set-Top Boxes
- VSAT Terminals

Functional Diagram appears at end of data sheet.



Maxim Integrated Products 1

For pricing, delivery, and ordering information, please contact Maxim/Dallas Direct! at 1-888-629-4642, or visit Maxim's website at www.maxim-ic.com.

Features

- ◆ Single 2.7V to 3.6V Operation
- ◆ Excellent Dynamic Performance
 - 48.4dB/44.7dB SINAD at $f_{IN} = 20\text{MHz}/200\text{MHz}$
 - 68.9dB/53dBc SFDR at $f_{IN} = 20\text{MHz}/200\text{MHz}$
- ◆ -72dB Interchannel Crosstalk at $f_{IN} = 20\text{MHz}$
- ◆ Low Power
 - 87mW (Normal Operation)
 - 9mW (Sleep Mode)
 - 0.3µW (Shutdown Mode)
- ◆ 0.05dB Gain and $\pm 0.05^\circ$ Phase Matching
- ◆ Wide $\pm 1\text{Vp-p}$ Differential Analog Input Voltage Range
- ◆ 400MHz -3dB Input Bandwidth
- ◆ On-Chip 2.048V Precision Bandgap Reference
- ◆ User-Selectable Output Format—Two's Complement or Offset Binary
- ◆ Pin-Compatible 8-Bit and 10-Bit Upgrades Available

Ordering Information

PART	TEMP RANGE	PIN-PACKAGE
MAX1196ECM	-40°C to +85°C	48 TQFP-EP*

*EP = Exposed pad.

Pin Configuration

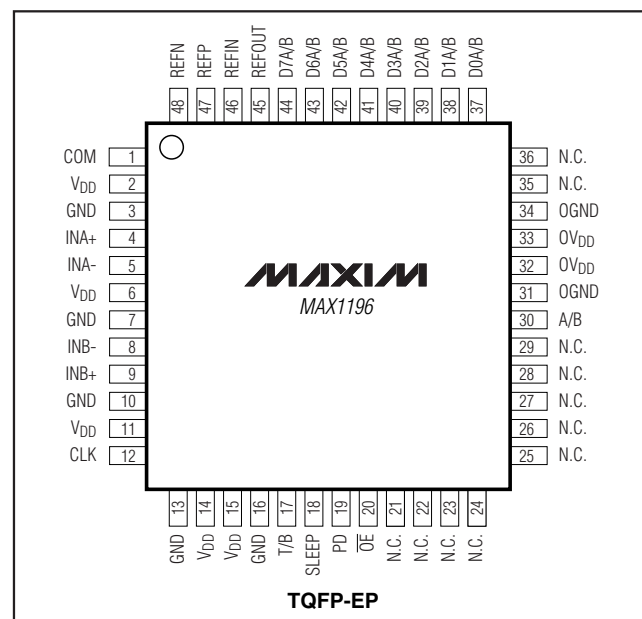

MAX1196

Dual 8-Bit, 40Mps, 3V, Low-Power ADC with Internal Reference and Multiplexed Parallel Outputs

ABSOLUTE MAXIMUM RATINGS

V _{DD} , OV _{DD} to GND	-0.3V to +3.6V
OGND to GND	-0.3V to +0.3V
INA+, INA-, INB+, INB- to GND	-0.3V to V _{DD}
REFIN, REFOUT, REFP, REFN, COM, CLK to GND	-0.3V to (V _{DD} + 0.3V)
OE, PD, SLEEP, T/B, D7A/B-D0A/B, A/B to OGND	-0.3V to (OV _{DD} + 0.3V)

Continuous Power Dissipation (T _A = +70°C)	48-Pin TQFP (derate 12.5mW/°C above +70°C)	1000mW
Operating Temperature Range		-40°C to +85°C
Junction Temperature		+150°C
Storage Temperature Range		-60°C to +150°C
Lead Temperature (soldering, 10s)		+300°C

Stresses beyond those listed under "Absolute Maximum Ratings" may cause permanent damage to the device. These are stress ratings only, and functional operation of the device at these or any other conditions beyond those indicated in the operational sections of the specifications is not implied. Exposure to absolute maximum rating conditions for extended periods may affect device reliability.

ELECTRICAL CHARACTERISTICS

(V_{DD} = OV_{DD} = 3V, 0.1μF and 2.2μF capacitors from REFP, REFN, and COM to GND; REFOUT connected to REFIN through a 10kΩ resistor, V_{IN} = 2V_{P-P} (differential with respect to COM), C_L = 10pF at digital outputs (Note 5), f_{CLK} = 40MHz, T_A = T_{MIN} to T_{MAX}, unless otherwise noted. ≥+25°C guaranteed by production test, <+25°C guaranteed by design and characterization. Typical values are at T_A = +25°C.)

PARAMETER	SYMBOL	CONDITIONS	MIN	TYP	MAX	UNITS
DC ACCURACY						
Resolution			8			Bits
Integral Nonlinearity	INL	f _{IN} = 7.51MHz (Note 1)		±0.3	±1	LSB
Differential Nonlinearity	DNL	f _{IN} = 7.51MHz, no missing codes guaranteed (Note 1)		±0.15	±1	LSB
Offset Error					±4	%FS
Gain Error					±4	%FS
Gain Temperature Coefficient				±100		ppm/°C
ANALOG INPUT						
Differential Input Voltage Range	V _{DIFF}	Differential or single-ended inputs		±1.0		V
Common-Mode Input Voltage Range	V _{CM}			V _{DD} / 2 ± 0.2		V
Input Resistance	R _{IN}	Switched capacitor load		140		kΩ
Input Capacitance	C _{IN}			5		pF
CONVERSION RATE						
Maximum Clock Frequency	f _{CLK}		40			MHz
Data Latency		CHA		5		Clock Cycles
		CHB		5.5		
DYNAMIC CHARACTERISTICS (f _{CLK} = 40MHz)						
Signal-to-Noise Ratio	SNR	f _{INA or B} = 2MHz at -1dB FS		48.7		dB
		f _{INA or B} = 7.5MHz at -1dB FS		48.7		
		f _{INA or B} = 20MHz at -1dB FS	47.5	48.5		
		f _{INA or B} = 101MHz at -1dB FS		48		
Signal-to-Noise and Distortion	SINAD	f _{INA or B} = 2MHz at -1dB FS		48.6		dB
		f _{INA or B} = 7.5MHz at -1dB FS		48.7		
		f _{INA or B} = 20MHz at -1dB FS	47	48.4		
		f _{INA or B} = 101MHz at -1dB FS		48		

Dual 8-Bit, 40MSPS, 3V, Low-Power ADC with Internal Reference and Multiplexed Parallel Outputs

MAX1196

ELECTRICAL CHARACTERISTICS (continued)

($V_{DD} = OV_{DD} = 3V$, $0.1\mu F$ and $2.2\mu F$ capacitors from REFP, REFN, and COM to GND; REFOUT connected to REFIN through a $10k\Omega$ resistor, $V_{IN} = 2V_{P-P}$ (differential with respect to COM), $C_L = 10pF$ at digital outputs (Note 5), $f_{CLK} = 40MHz$, $T_A = T_{MIN}$ to T_{MAX} , unless otherwise noted. $\geq +25^\circ C$ guaranteed by production test, $< +25^\circ C$ guaranteed by design and characterization. Typical values are at $T_A = +25^\circ C$.)

PARAMETER	SYMBOL	CONDITIONS	MIN	TYP	MAX	UNITS
Spurious-Free Dynamic Range	SFDR	$f_{INA \text{ or } B} = 2MHz$ at -1dB FS		69		dBc
		$f_{INA \text{ or } B} = 7.5MHz$ at -1dB FS		70		
		$f_{INA \text{ or } B} = 20MHz$ at -1dB FS	60	68.9		
		$f_{INA \text{ or } B} = 101MHz$ at -1dB FS		65		
Third-Harmonic Distortion	HD3	$f_{INA \text{ or } B} = 2MHz$ at -1dB FS		-72		dBc
		$f_{INA \text{ or } B} = 7.5MHz$ at -1dB FS		-73.7		
		$f_{INA \text{ or } B} = 20MHz$ at -1dB FS		-75		
		$f_{INA \text{ or } B} = 101MHz$ at -1dB FS		-67		
Intermodulation Distortion (First Five Odd-Order IMDs) (Note 2)	IMD	$f_{IN1(A \text{ or } B)} = 1.997MHz$ at -7dB FS, $f_{IN2(A \text{ or } B)} = 2.046MHz$ at -7dB FS		-68		dBc
Third-Order Intermodulation Distortion (Note 2)	IM3	$f_{IN1(A \text{ or } B)} = 1.997MHz$ at -7dB FS, $f_{IN2(A \text{ or } B)} = 2.046MHz$ at -7dB FS		-73.2		dBc
Total Harmonic Distortion (First Four Harmonics)	THD	$f_{INA \text{ or } B} = 2MHz$ at -1dB FS		-70		dBc
		$f_{INA \text{ or } B} = 7.5MHz$ at -1dB FS		-69		
		$f_{INA \text{ or } B} = 20MHz$ at -1dB FS		-69	-57	
		$f_{INA \text{ or } B} = 101MHz$ at -1dB FS		-63		
Small-Signal Bandwidth		Input at -20dB FS, differential inputs		500		MHz
Full-Power Bandwidth	FPBW	Input at -1dB FS, differential inputs		400		MHz
Gain Flatness (12MHz Spacing) (Note 3)		$f_{IN1(A \text{ or } B)} = 106MHz$ at -1dB FS, $f_{IN2(A \text{ or } B)} = 118MHz$ at -1dB FS		0.05		dB
Aperture Delay	t_{AD}			1		ns
Aperture Jitter	t_{AJ}	1dB SNR degradation at Nyquist		2		psRMS
Overdrive Recovery Time		For $1.5 \times$ full-scale input		2		ns
INTERNAL REFERENCE (REFIN = REFOUT through $10k\Omega$ resistor; REFP, REFN, and COM levels are generated internally.)						
Reference Output Voltage	V_{REFOUT}	(Note 4)		2.048 $\pm 3\%$		V
Positive Reference Output Voltage	V_{REFP}	(Note 5)		2.012		V
Negative Reference Output Voltage	V_{REFN}	(Note 5)		0.988		V
Common-Mode Level	V_{COM}	(Note 5)		$V_{DD} / 2$ ± 0.1		V
Differential Reference Output Voltage Range	ΔV_{REF}	$\Delta V_{REF} = V_{REFP} - V_{REFN}$		1.024 $\pm 3\%$		V
Reference Temperature Coefficient	TC_{REF}			± 100		ppm/ $^\circ C$

Dual 8-Bit, 40Mps, 3V, Low-Power ADC with Internal Reference and Multiplexed Parallel Outputs

ELECTRICAL CHARACTERISTICS (continued)

($V_{DD} = OV_{DD} = 3V$, $0.1\mu F$ and $2.2\mu F$ capacitors from REFP, REFN, and COM to GND; REFOUT connected to REFIN through a $10k\Omega$ resistor, $V_{IN} = 2V_{P-P}$ (differential with respect to COM), $C_L = 10pF$ at digital outputs (Note 5), $f_{CLK} = 40MHz$, $T_A = T_{MIN}$ to T_{MAX} , unless otherwise noted. $\geq +25^\circ C$ guaranteed by production test, $< +25^\circ C$ guaranteed by design and characterization. Typical values are at $T_A = +25^\circ C$.)

PARAMETER	SYMBOL	CONDITIONS	MIN	TYP	MAX	UNITS
BUFFERED EXTERNAL REFERENCE ($V_{REFIN} = 2.048V$)						
Positive Reference Output Voltage	V_{REFP}	(Note 5)		2.012		V
Negative Reference Output Voltage	V_{REFN}	(Note 5)		0.988		V
Common-Mode Level	V_{COM}	(Note 5)		$V_{DD} / 2$ ± 0.1		V
Differential Reference Output Voltage Range	ΔV_{REF}	$\Delta V_{REF} = V_{REFP} - V_{REFN}$		1.024 $\pm 2\%$		V
REFIN Resistance	R_{REFIN}			>50		$M\Omega$
Maximum REFP, COM Source Current	I_{SOURCE}			5		mA
Maximum REFP, COM Sink Current	I_{SINK}			-250		μA
Maximum REFN Source Current	I_{SOURCE}			250		μA
Maximum REFN Sink Current	I_{SINK}			-5		mA
UNBUFFERED EXTERNAL REFERENCE ($V_{REFIN} = AGND$, reference voltage applied to REFP, REFN, and COM)						
REFP, REFN Input Resistance	R_{REFP}, R_{REFN}	Measured between REFP and REFN		4		$k\Omega$
REFP, REFN, COM Input Capacitance	C_{IN}			15		pF
Differential Reference Input Voltage Range	ΔV_{REF}	$\Delta V_{REF} = V_{REFP} - V_{REFN}$		1.024 $\pm 10\%$		V
COM Input Voltage Range	V_{COM}			$V_{DD} / 2$ $\pm 5\%$		V
REFP Input Voltage	V_{REFP}			$V_{COM} + \Delta V_{REF} / 2$		V
REFN Input Voltage	V_{REFN}			$V_{COM} - \Delta V_{REF} / 2$		V
DIGITAL INPUTS (CLK, PD, \overline{OE} , SLEEP, T/B)						
Input High Threshold	V_{IH}	CLK		$0.8 \times V_{DD}$		V
		PD, \overline{OE} , SLEEP, T/B		$0.8 \times OV_{DD}$		
Input Low Threshold	V_{IL}	CLK			$0.2 \times V_{DD}$	V
		PD, \overline{OE} , SLEEP, T/B			$0.2 \times OV_{DD}$	

Dual 8-Bit, 40Mps, 3V, Low-Power ADC with Internal Reference and Multiplexed Parallel Outputs

ELECTRICAL CHARACTERISTICS (continued)

($V_{DD} = OV_{DD} = 3V$, 0.1 μF and 2.2 μF capacitors from REFP, REFN, and COM to GND; REFOUT connected to REFIN through a 10k Ω resistor, $V_{IN} = 2V_{P-P}$ (differential with respect to COM), $C_L = 10pF$ at digital outputs (Note 5), $f_{CLK} = 40MHz$, $T_A = T_{MIN}$ to T_{MAX} , unless otherwise noted. $\geq +25^{\circ}C$ guaranteed by production test, $< +25^{\circ}C$ guaranteed by design and characterization. Typical values are at $T_A = +25^{\circ}C$.)

PARAMETER	SYMBOL	CONDITIONS	MIN	TYP	MAX	UNITS
Input Hysteresis	V_{HYST}			0.15		V
Input Leakage	I_{IH}	$V_{IH} = V_{DD} = OV_{DD}$			± 20	μA
	I_{IL}	$V_{IL} = 0$			± 20	
Input Capacitance	C_{IN}			5		pF
DIGITAL OUTPUTS (D0A/B–D7A/B, A/B)						
Output Voltage Low	V_{OL}	$I_{SINK} = -200\mu A$			0.2	V
Output Voltage High	V_{OH}	$I_{SOURCE} = 200\mu A$	$OV_{DD} - 0.2$			V
Three-State Leakage Current	I_{LEAK}	$\overline{OE} = OV_{DD}$			± 10	μA
Three-State Output Capacitance	C_{OUT}	$\overline{OE} = OV_{DD}$		5		pF
POWER REQUIREMENTS						
Analog Supply Voltage Range	V_{DD}		2.7	3	3.6	V
Output Supply Voltage Range	OV_{DD}		1.7	3	3.6	V
Analog Supply Current	I_{VDD}	Operating, $f_{INA\&B} = 20MHz$ at -1dB FS applied to both channels		29	36	mA
		Sleep mode		3		
		Shutdown, clock idle, $PD = \overline{OE} = OV_{DD}$		0.1	20	μA
Output Supply Current	I_{OVDD}	Operating, $f_{INA\&B} = 20MHz$ at -1dB FS applied to both channels (Note 6)		8		mA
		Sleep mode		3		
		Shutdown, clock idle, $PD = \overline{OE} = OV_{DD}$		3	10	μA
Analog Power Dissipation	PDISS	Operating, $f_{INA\&B} = 20MHz$ at -1dB FS applied to both channels		87	108	mW
		Sleep mode		9		
		Shutdown, clock idle, $PD = \overline{OE} = OV_{DD}$		0.3	60	μW
Power-Supply Rejection	PSRR	Offset, $V_{DD} \pm 5\%$		± 3		mV/V
		Gain, $V_{DD} \pm 5\%$		± 3		
TIMING CHARACTERISTICS						
CLK Rise to CHA Output Data Valid	t_{DOA}	$C_L = 20pF$ (Notes 1, 7)		6	8.25	ns
CLK Fall to CHB Output Data Valid	t_{DOB}	$C_L = 20pF$ (Notes 1, 7)		6	8.25	ns
Clock Rise/Fall to A/B Rise/Fall Time	$t_{DA/B}$			6		ns
\overline{OE} Fall to Output Enable Time	t_{ENABLE}			5		ns
\overline{OE} Rise to Output Disable Time	$t_{DISABLE}$			5		ns
CLK Pulse Width High	t_{CH}	Clock period: 25ns (Note 7)		12.5 ± 1.5		ns

Dual 8-Bit, 40MSPS, 3V, Low-Power ADC with Internal Reference and Multiplexed Parallel Outputs

ELECTRICAL CHARACTERISTICS (continued)

($V_{DD} = OV_{DD} = 3V$, $0.1\mu F$ and $2.2\mu F$ capacitors from REFP, REFN, and COM to GND; REFOUT connected to REFIN through a $10k\Omega$ resistor, $V_{IN} = 2V_{P-P}$ (differential with respect to COM), $C_L = 10pF$ at digital outputs (Note 5), $f_{CLK} = 40MHz$, $T_A = T_{MIN}$ to T_{MAX} , unless otherwise noted. $\geq +25^\circ C$ guaranteed by production test, $< +25^\circ C$ guaranteed by design and characterization. Typical values are at $T_A = +25^\circ C$.)

PARAMETER	SYMBOL	CONDITIONS	MIN	TYP	MAX	UNITS
CLK Pulse Width Low	t_{CL}	Clock period: 25ns (Note 7)		12.5 ± 1.5		ns
Wake-Up Time	t_{WAKE}	Wake-up from sleep mode		1		μs
		Wake-up from shutdown mode (Note 8)		20		
CHANNEL-TO-CHANNEL MATCHING						
Crosstalk		$f_{INA \text{ or } B} = 20MHz$ at -1dB FS (Note 9)		-72		dB
Gain Matching		$f_{INA \text{ or } B} = 20MHz$ at -1dB FS (Note 10)		0.05		dB
Phase Matching		$f_{INA \text{ or } B} = 20MHz$ at -1dB FS (Note 11)		± 0.05		Degrees

Note 1: Guaranteed by design. Not subject to production testing.

Note 2: Intermodulation distortion is the total power of the intermodulation products relative to the total input power.

Note 3: Analog attenuation is defined as the amount of attenuation of the fundamental bin from a converted FFT between two applied input signals with the same magnitude (peak-to-peak) at f_{IN1} and f_{IN2} .

Note 4: REFIN and REFOUT should be bypassed to GND with a $0.1\mu F$ (min) and $2.2\mu F$ (typ) capacitor.

Note 5: REFP, REFN, and COM should be bypassed to GND with a $0.1\mu F$ (min) and $2.2\mu F$ (typ) capacitor.

Note 6: Typical digital output current at $f_{INA\&B} = 20MHz$. For digital output currents vs. analog input frequency, see the *Typical Operating Characteristics*.

Note 7: See Figure 3 for detailed system timing diagrams. Clock to data valid timing is measured from 50% of the clock level to 50% of the data output level.

Note 8: SINAD settles to within 0.5dB of its typical value in unbuffered external reference mode.

Note 9: Crosstalk rejection is tested by applying a test tone to one channel and holding the other channel at DC level. Crosstalk is measured by calculating the power ratio of the fundamental of each channel's FFT.

Note 10: Amplitude matching is measured by applying the same signal to each channel and comparing the magnitude of the fundamental of the calculated FFT.

Note 11: Phase matching is measured by applying the same signal to each channel and comparing the phase of the fundamental of the calculated FFT. The data from both ADC channels must be captured simultaneously during this test.

Dual 8-Bit, 40MSPS, 3V, Low-Power ADC with Internal Reference and Multiplexed Parallel Outputs

Typical Operating Characteristics

($V_{DD} = OV_{DD} = 3V$, $V_{REFIN} = 2.048V$, differential input at $-1dB$ FS, $f_{CLK} = 40MHz$, $C_L \approx 10pF$, $T_A = +25^\circ C$, unless otherwise noted.)

MAX1196

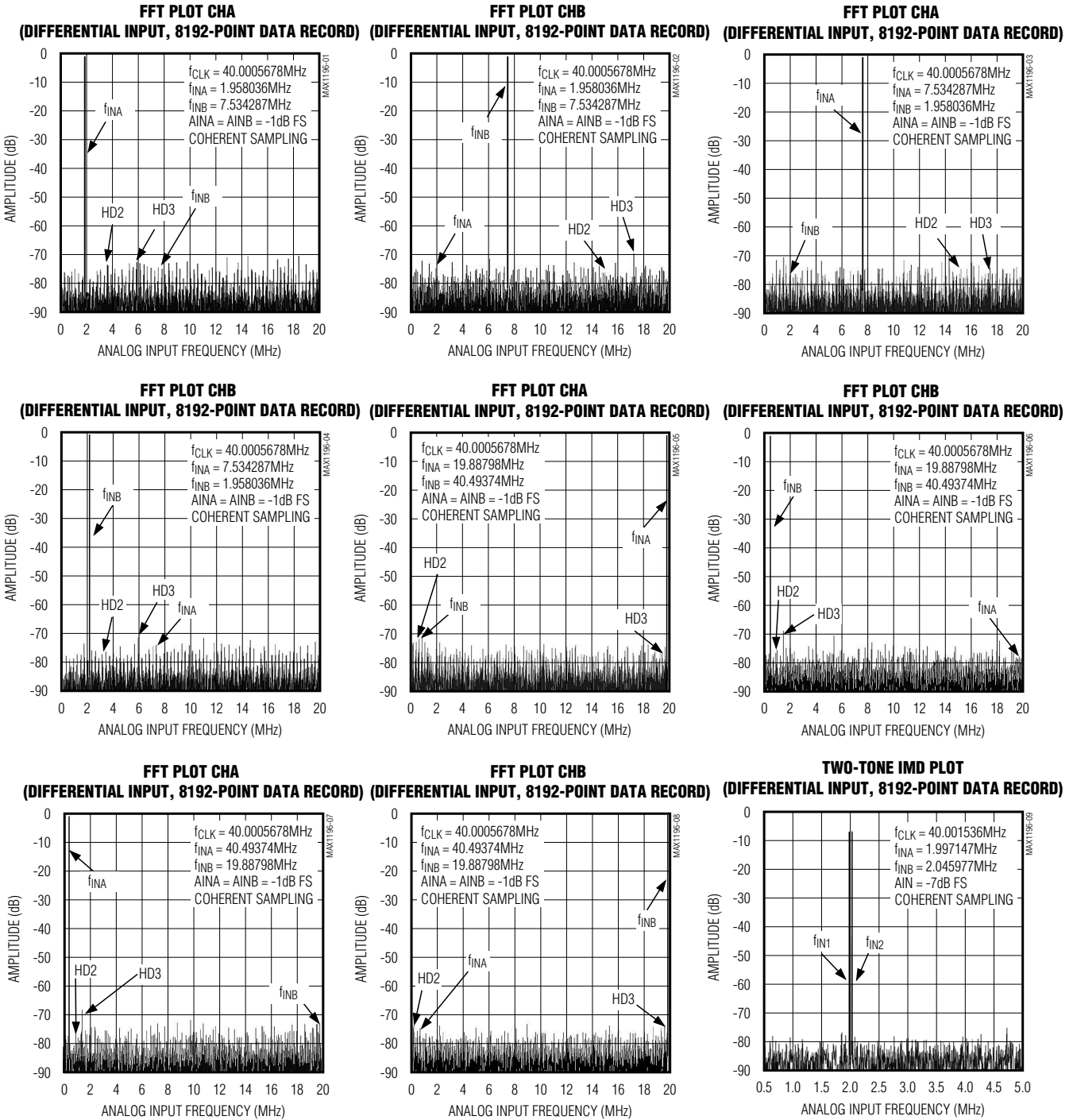

Dual 8-Bit, 40Mps, 3V, Low-Power ADC with Internal Reference and Multiplexed Parallel Outputs

Typical Operating Characteristics (continued)

($V_{DD} = OV_{DD} = 3V$, $V_{REFIN} = 2.048V$, differential input at $-1dB$ FS, $f_{CLK} = 40MHz$, $C_L \approx 10pF$, $T_A = +25^\circ C$, unless otherwise noted.)

**TWO-TONE IMD PLOT
(DIFFERENTIAL INPUT, 8192-POINT DATA RECORD)**

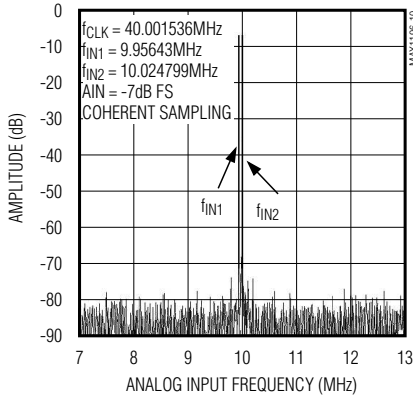

**SIGNAL-TO-NOISE RATIO
vs. ANALOG INPUT FREQUENCY**

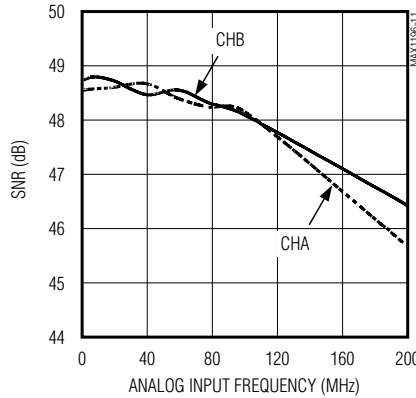

**SIGNAL-TO-NOISE + DISTORTION
vs. ANALOG INPUT FREQUENCY**

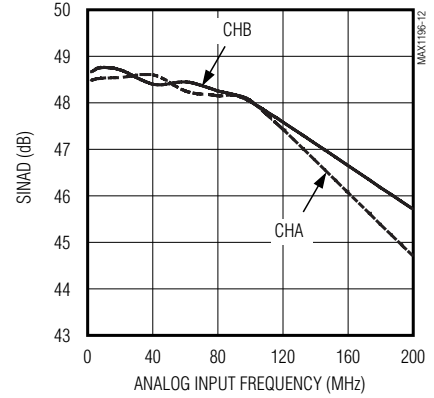

**TOTAL HARMONIC DISTORTION
vs. ANALOG INPUT FREQUENCY**

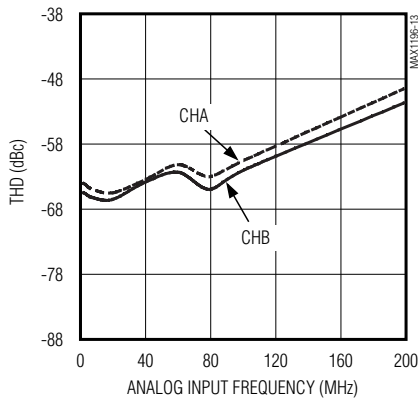

**SPURIOUS-FREE DYNAMIC RANGE
vs. ANALOG INPUT FREQUENCY**

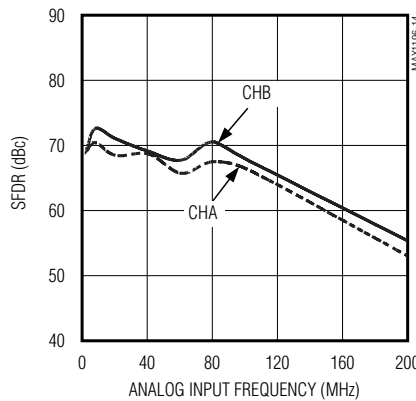

**FULL-POWER INPUT BANDWIDTH
vs. ANALOG INPUT FREQUENCY, DIFFERENTIAL**

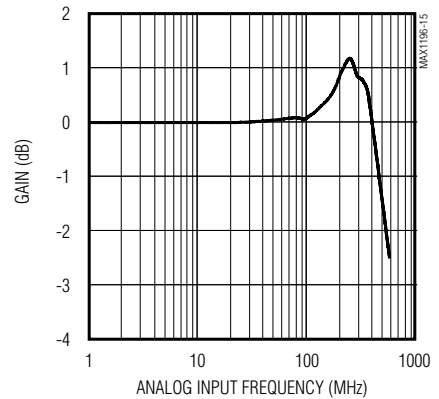

**SMALL-SIGNAL INPUT BANDWIDTH
vs. ANALOG INPUT FREQUENCY, DIFFERENTIAL**

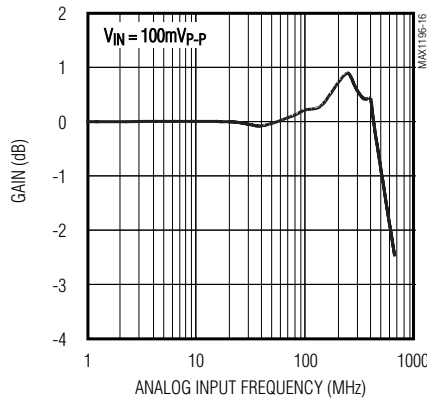

**SIGNAL-TO-NOISE RATIO
vs. INPUT POWER ($f_{IN} = 19.88798MHz$)**

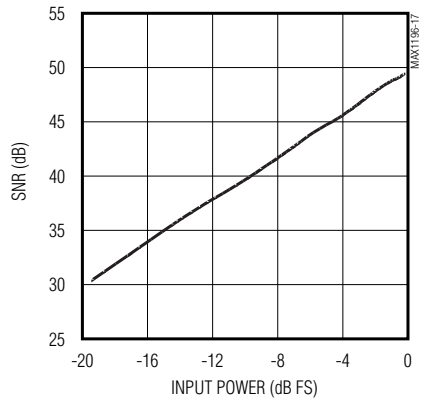

**SIGNAL-TO-NOISE + DISTORTION
vs. INPUT POWER ($f_{IN} = 19.88798MHz$)**

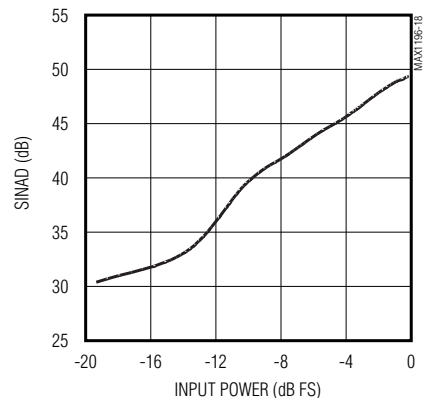

Dual 8-Bit, 40Mps, 3V, Low-Power ADC with Internal Reference and Multiplexed Parallel Outputs

MAX1196

Typical Operating Characteristics (continued)

(VDD = OVDD = 3V, VREFIN = 2.048V, differential input at -1dB FS, fCLK = 40MHz, CL ≈ 10pF, TA = +25°C, unless otherwise noted.)

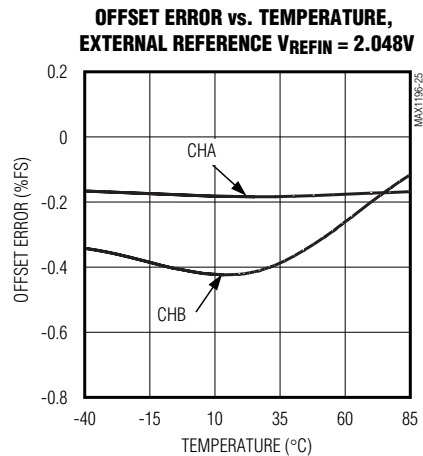
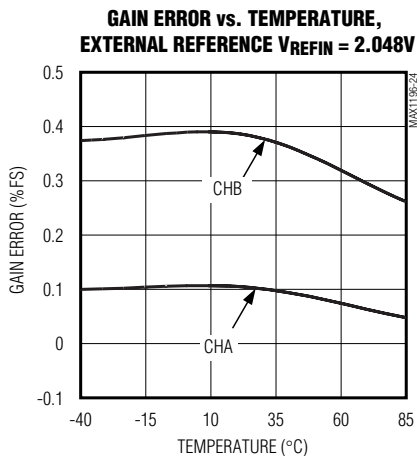
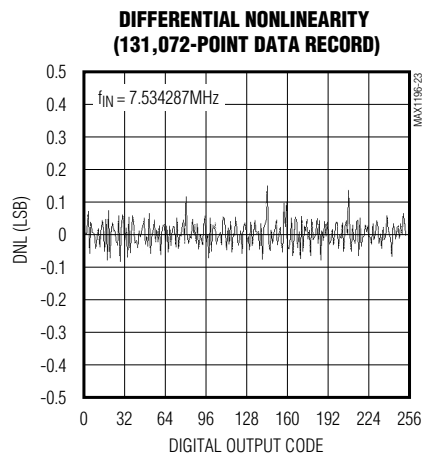
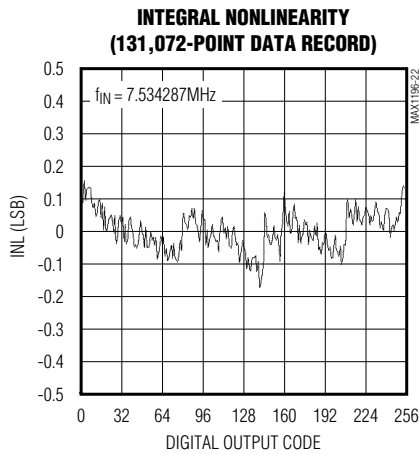
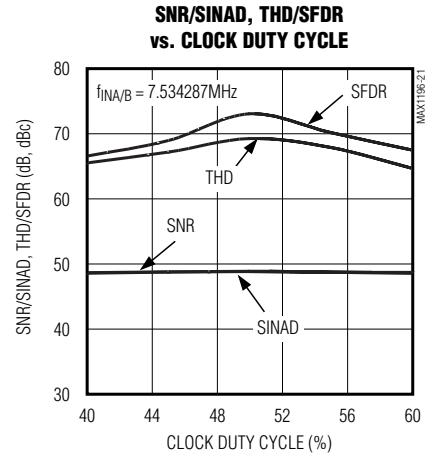
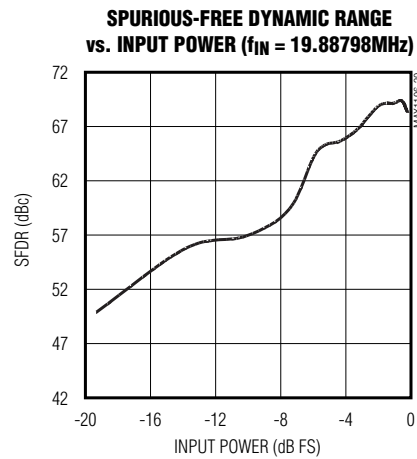
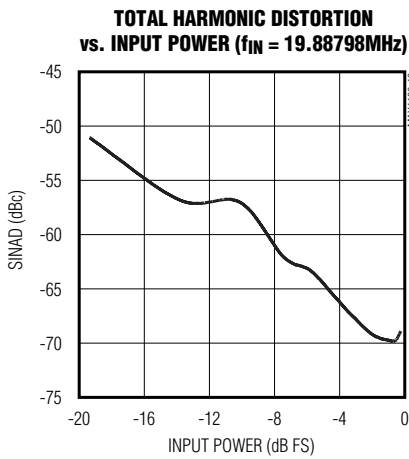

Dual 8-Bit, 40Mps, 3V, Low-Power ADC with Internal Reference and Multiplexed Parallel Outputs

Typical Operating Characteristics (continued)

($V_{DD} = OV_{DD} = 3V$, $V_{REFIN} = 2.048V$, differential input at -1dB FS, $f_{CLK} = 40MHz$, $C_L \approx 10pF$, $T_A = +25^\circ C$, unless otherwise noted.)

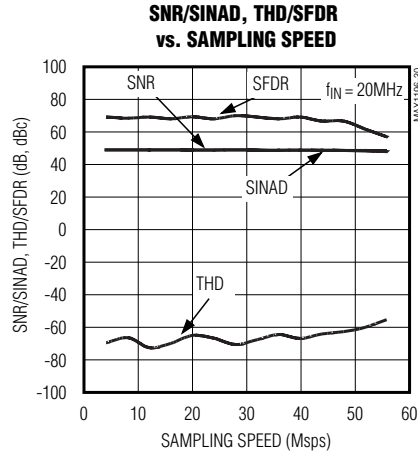
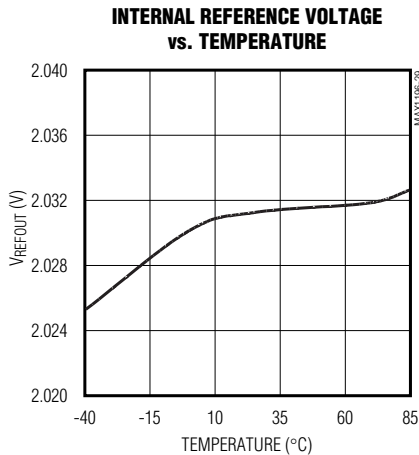
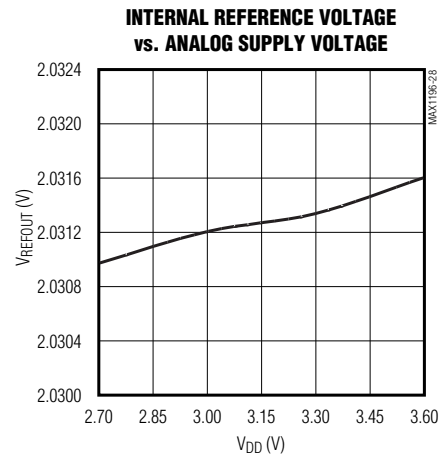
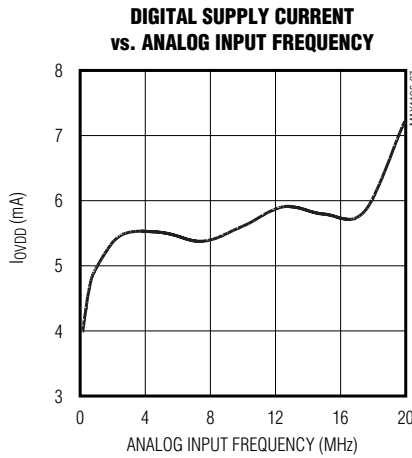
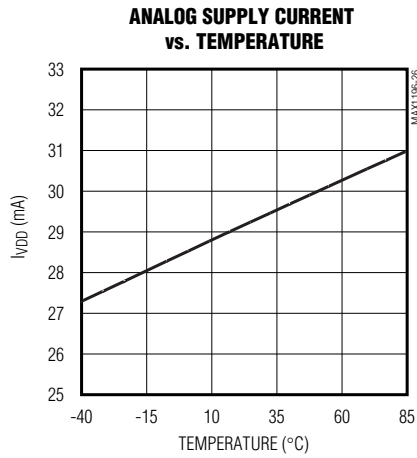

Pin Description

PIN	NAME	FUNCTION
1	COM	Common-Mode Voltage Input/Output. Bypass to GND with a $\geq 0.1\mu F$ capacitor.
2, 6, 11, 14, 15	V_{DD}	Analog Supply Voltage. Bypass to GND with a capacitor combination of $2.2\mu F$ in parallel with $0.1\mu F$.
3, 7, 10, 13, 16	GND	Analog Ground
4	INA+	Channel 'A' Positive Analog Input. For single-ended operation, connect signal source to INA+.
5	INA-	Channel 'A' Negative Analog Input. For single-ended operation, connect INA- to COM.
8	INB-	Channel 'B' Negative Analog Input. For single-ended operation, connect INB- to COM.
9	INB+	Channel 'B' Positive Analog Input. For single-ended operation, connect signal source to INB+.
12	CLK	Converter Clock Input

Dual 8-Bit, 40MSPS, 3V, Low-Power ADC with Internal Reference and Multiplexed Parallel Outputs

Pin Description (continued)

MAX1196

PIN	NAME	FUNCTION
17	T/B	T/B selects the ADC digital output format. High: Two's complement. Low: Straight offset binary.
18	SLEEP	Sleep Mode Input. High: Deactivates the two ADCs, but leaves the reference bias circuit active. Low: Normal operation.
19	PD	High-Active Power-Down Input. High: Power-down mode Low: Normal operation
20	\overline{OE}	Low-Active Output Enable Input. High: Digital outputs disabled Low: Digital outputs enabled
21–29, 35, 36	N.C.	No Connection. Do not connect.
30	A/B	A/B Data Indicator. This digital output indicates CHA data (A/B = 1) or CHB data (A/B = 0) to be present on the output. A/B follows the external clock signal with typically 6ns delay.
31, 34	OGND	Output-Driver Ground
32, 33	OV _{DD}	Output-Driver Supply Voltage. Bypass to OGND with a capacitor combination of 2.2μF in parallel with 0.1μF.
37	D0A/B	Three-State Digital Output, Bit 0. Depending on status of A/B, output data reflects channel A or channel B data.
38	D1A/B	Three-State Digital Output, Bit 1. Depending on status of A/B, output data reflects channel A or channel B data.
39	D2A/B	Three-State Digital Output, Bit 2. Depending on status of A/B, output data reflects channel A or channel B data.
40	D3A/B	Three-State Digital Output, Bit 3. Depending on status of A/B, output data reflects channel A or channel B data.
41	D4A/B	Three-State Digital Output, Bit 4. Depending on status of A/B, output data reflects channel A or channel B data.
42	D5A/B	Three-State Digital Output, Bit 5. Depending on status of A/B, output data reflects channel A or channel B data.
43	D6A/B	Three-State Digital Output, Bit 6. Depending on status of A/B, output data reflects channel A or channel B data.
44	D7A/B	Three-State Digital Output, Bit 7 (MSB). Depending on status of A/B, output data reflects channel A or channel B data.
45	REFOUT	Internal Reference Voltage Output. Can be connected to REFIN through a resistor or a resistor-divider.
46	REFIN	Reference Input. $V_{REFIN} = 2 \times (V_{REFP} - V_{REFN})$. Bypass to GND with a $\geq 0.1\mu F$ capacitor.
47	REFP	Positive Reference I/O. Conversion range is $\pm(V_{REFP} - V_{REFN})$. Bypass to GND with a $\geq 0.1\mu F$ capacitor.
48	REFN	Negative Reference I/O. Conversion range is $\pm(V_{REFP} - V_{REFN})$. Bypass to GND with a $\geq 0.1\mu F$ capacitor.

Dual 8-Bit, 40Mps, 3V, Low-Power ADC with Internal Reference and Multiplexed Parallel Outputs

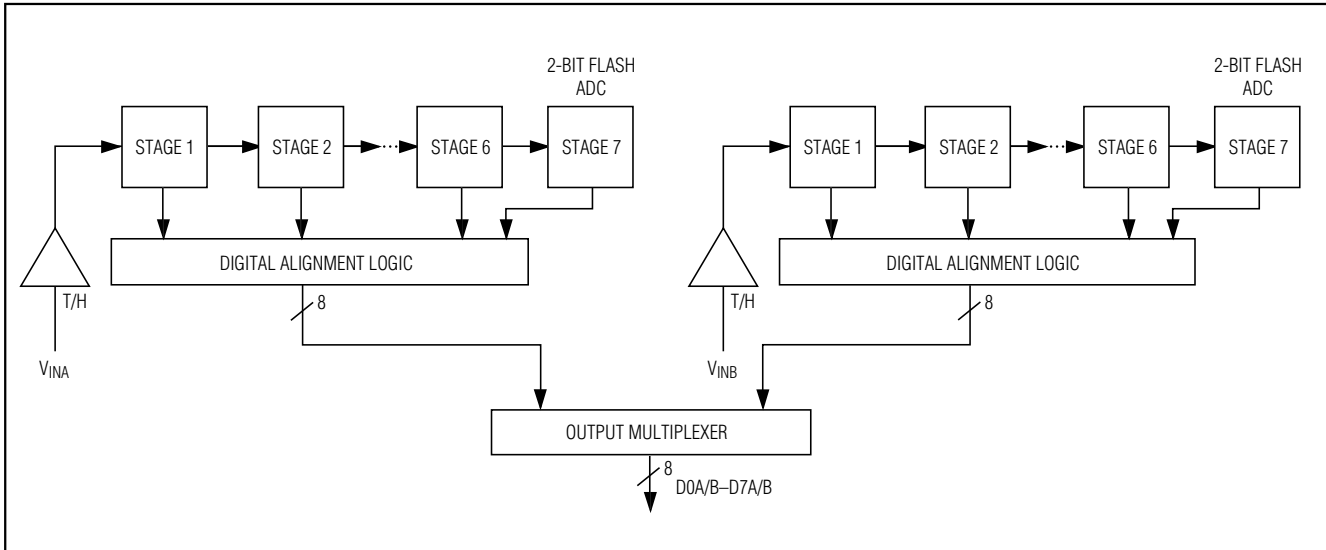

Figure 1. Pipelined Architecture—Stage Blocks

Detailed Description

The MAX1196 uses a 7-stage, fully differential, pipelined architecture (Figure 1) that allows for high-speed conversion while minimizing power consumption. Samples taken at the inputs move progressively through the pipeline stages every half clock cycle. Including the delay through the output latch, the total clock-cycle latency is 5 clock cycles for CHA and 5.5 clock cycles for CHB.

Flash ADCs convert the held input voltages into a digital code. Internal MDACs convert the digitized results back into analog voltages, which are then subtracted from the original held input signals. The resulting error signals are then multiplied by two, and the residues are passed along to the next pipeline stages where the process is repeated until the signals have been processed by all 7 stages.

Both input channels are sampled on the rising edge of the clock and the resulting data is multiplexed at the output. CHA data is updated on the rising edge (5 clock cycles later) and CHB data is updated on the falling edge (5.5 clock cycles later) of the clock signal. The A/B indicator follows the clock signal with a typical delay time of 6ns and remains high when CHA data is updated and low when CHB data is updated.

Input Track-and-Hold (T/H) Circuits

Figure 2 displays a simplified functional diagram of the input track-and-hold (T/H) circuits in both track and hold mode. In track mode, switches S1, S2a, S2b, S4a,

S4b, S5a, and S5b are closed. The fully differential circuits sample the input signals onto the two capacitors (C2a and C2b) through switches S4a and S4b. S2a and S2b set the common mode for the amplifier input, and open simultaneously with S1, sampling the input waveform. Switches S4a, S4b, S5a, and S5b are then opened before switches S3a and S3b connect capacitors C1a and C1b to the output of the amplifier and switch S4c is closed. The resulting differential voltages are held on capacitors C2a and C2b. The amplifiers are used to charge capacitors C1a and C1b to the same values originally held on C2a and C2b. These values are then presented to the first stage quantizers and isolate the pipelines from the fast-changing inputs. The wide input bandwidth T/H amplifiers allow the MAX1196 to track and sample/hold analog inputs of high frequencies ($>N_{\text{Nyquist}}$). Both ADC inputs (INA+, INB+, INA-, and INB-) can be driven either differentially or single ended. Match the impedance of INA+ and INA-, as well as INB+ and INB-, and set the common-mode voltage to midsupply ($V_{\text{DD}}/2$) for optimum performance.

Analog Inputs and Reference Configurations

The full-scale range of the MAX1196 is determined by the internally generated voltage difference between REFP ($V_{\text{DD}}/2 + V_{\text{REFIN}}/4$) and REFN ($V_{\text{DD}}/2 - V_{\text{REFIN}}/4$). The full-scale range for both on-chip ADCs is adjustable through the REFIN pin, which is provided for this purpose.

Dual 8-Bit, 40Mps, 3V, Low-Power ADC with Internal Reference and Multiplexed Parallel Outputs

MAX1196

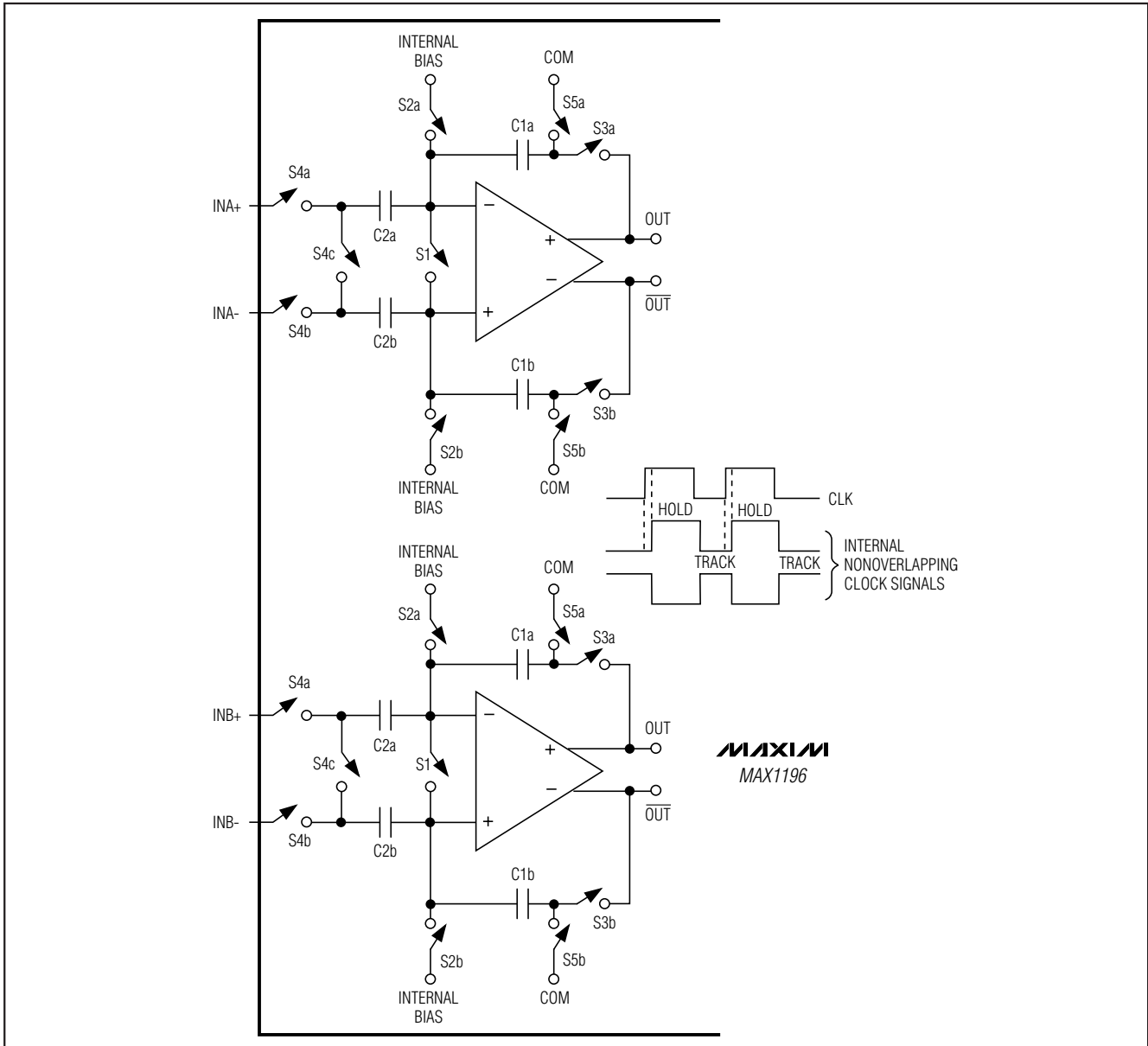

Figure 2. MAX1196 T/H Amplifiers

The MAX1196 provides three modes of reference operation:

- Internal reference mode
- Buffered external reference mode
- Unbuffered external reference mode

In internal reference mode, connect the internal reference output REFOUT to REFIN through a resistor (e.g.,

10k Ω) or resistor-divider, if an application requires a reduced full-scale range. For stability and noise-filtering purposes, bypass REFIN with a $\geq 0.1\mu\text{F}$ capacitor to GND. In internal reference mode, REFOUT, COM, REFP, and REFN become low-impedance outputs.

In buffered external reference mode, adjust the reference voltage levels externally by applying a stable and accurate voltage at REFIN. In this mode, COM, REFP,

Dual 8-Bit, 40Mps, 3V, Low-Power ADC with Internal Reference and Multiplexed Parallel Outputs

and REFN are outputs. REFOUT can be left open or connected to REFIN through a >10kΩ resistor.

In unbuffered external reference mode, connect REFIN to GND. This deactivates the on-chip reference buffers for REFP, COM, and REFN. With their buffers shut down, these nodes become high-impedance inputs and can be driven through separate, external reference sources.

For detailed circuit suggestions and how to drive this dual ADC in buffered/unbuffered external reference mode, see the *Applications Information* section.

Clock Input (CLK)

The MAX1196's CLK input accepts CMOS-compatible clock signal. Since the interstage conversion of the device depends on the repeatability of the rising and falling edges of the external clock, use a clock with low jitter and fast rise and fall times (<2ns). In particular, sampling occurs on the rising edge of the clock signal, requiring this edge to provide lowest possible jitter. Any significant aperture jitter would limit the SNR performance of the on-chip ADCs as follows:

$$SNR = 20 \times \log \left(\frac{1}{2 \times \pi \times f_{IN} \times t_{AJ}} \right)$$

where f_{IN} represents the analog input frequency and t_{AJ} is the time of the aperture jitter.

Clock jitter is especially critical for undersampling applications. The clock input should always be considered as an analog input and routed away from any analog input or other digital signal lines.

The MAX1196 clock input operates with a voltage threshold set to $V_{DD}/2$. Clock inputs with a duty cycle other than 50%, must meet the specifications for high and low periods as stated in the *Electrical Characteristics*.

System Timing Requirements

Figure 3 shows the relationship between clock and analog input, A/B indicator, and the resulting valid CHA/CHB data output. CHA and CHB data are sampled on the rising edge of the clock signal. Following the rising edge of the 5th clock cycles, the digitized value of the original CHA sample is presented at the output, followed one-half clock cycle later by the digitized value of the original CHB sample.

A channel selection signal (A/B indicator) allows the user to determine which output data represents which input channel. With A/B = 1, digitized data from CHA is present at the output and with A/B = 0 digitized data from CHB is present.

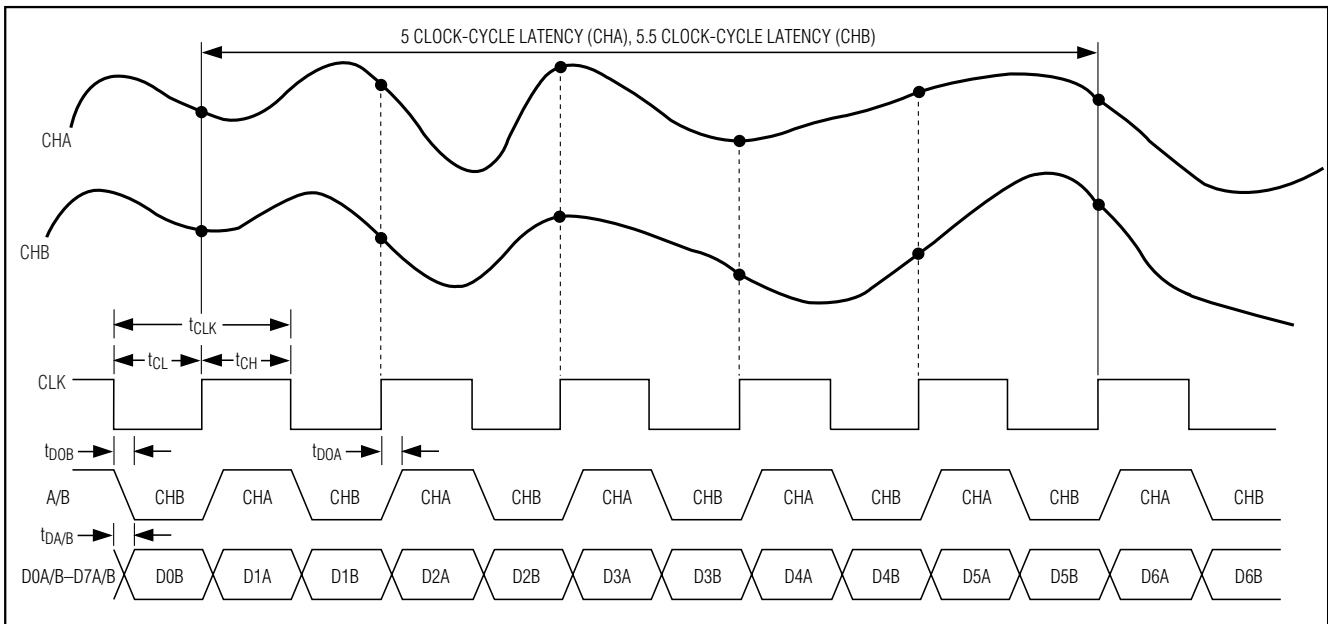

Figure 3. System Timing Diagram

Dual 8-Bit, 40MSPS, 3V, Low-Power ADC with Internal Reference and Multiplexed Parallel Outputs

Digital Output Data, Output Data Format Selection (T/B), Output Enable (OE), Channel Selection (A/B)

All digital outputs, D0A/B–D7A/B (CHA or CHB data) and A/B are TTL/CMOS-logic compatible. The output coding can be chosen to be either offset binary or two’s complement (Table 1) controlled by a single pin (T/B). Pull T/B low to select offset binary and high to activate two’s complement output coding. The capacitive load on the digital outputs D0A/B–D7A/B should be kept as low as possible (<15pF), to avoid large digital currents that could feed back into the analog portion of the MAX1196, thereby degrading its dynamic performance. Using buffers on the digital outputs of the ADCs can further isolate the digital outputs from heavy capacitive loads. To further improve the dynamic performance of the MAX1196, small-series resistors (e.g., 100Ω) can be added to the digital output paths, close to the MAX1196.

Figure 4 displays the timing relationship between output enable and data output valid as well as power-down/wake-up and data output valid.

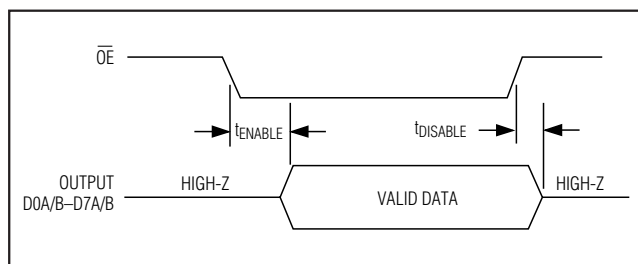

Figure 4. Output Timing Diagram

Power-Down (PD) and Sleep (SLEEP) Modes

The MAX1196 offers two power-save modes—sleep and full power-down mode. In sleep mode (SLEEP = 1), only the reference bias circuit is active (both ADCs are disabled), and current consumption is reduced to 3mA.

To enter full power-down mode, pull PD high. With \overline{OE} simultaneously low, all outputs are latched at the last value prior to the power down. Pulling \overline{OE} high forces the digital outputs into a high-impedance state.

Applications Information

Figure 5 depicts a typical application circuit containing two single-ended-to-differential converters. The internal reference provides a $V_{DD}/2$ output voltage for level-shifting purposes. The input is buffered and then split to a voltage follower and inverter. One lowpass filter per amplifier suppresses some of the wideband noise associated with high-speed operational amplifiers. The user can select the R_{ISO} and C_{IN} values to optimize the filter performance, to suit a particular application. For the application in Figure 5, an R_{ISO} of 50Ω is placed before the capacitive load to prevent ringing and oscillation. The 22pF C_{IN} capacitor acts as a small filter capacitor.

Using Transformer Coupling

An RF transformer (Figure 6) provides an excellent solution to convert a single-ended source signal to a fully differential signal, required by the MAX1196 for optimum performance. Connecting the center tap of the transformer to COM provides a $V_{DD}/2$ DC level shift to the input. Although a 1:1 transformer is shown, a step-up transformer can be selected to reduce the drive requirements. A reduced signal swing from the input driver, such as an op amp, can also improve the overall distortion.

Table 1. MAX1196 Output Codes for Differential Inputs

DIFFERENTIAL INPUT VOLTAGE*	DIFFERENTIAL INPUT	STRAIGHT OFFSET BINARY T/B = 0	TWO'S COMPLEMENT T/B = 1
$V_{REF} \times 255/256$	+Full Scale - 1LSB	1111 1111	0111 1111
$V_{REF} \times 1/256$	+1LSB	1000 0001	0000 0001
0	Bipolar Zero	1000 0000	0000 0000
$-V_{REF} \times 1/256$	-1LSB	0111 1111	1111 1111
$-V_{REF} \times 255/256$	-Full Scale + 1LSB	0000 0001	1000 0001
$-V_{REF} \times 256/256$	-Full Scale	0000 0000	1000 0000

* $V_{REF} = V_{REFP} - V_{REFN}$

Dual 8-Bit, 40Mps, 3V, Low-Power ADC with Internal Reference and Multiplexed Parallel Outputs

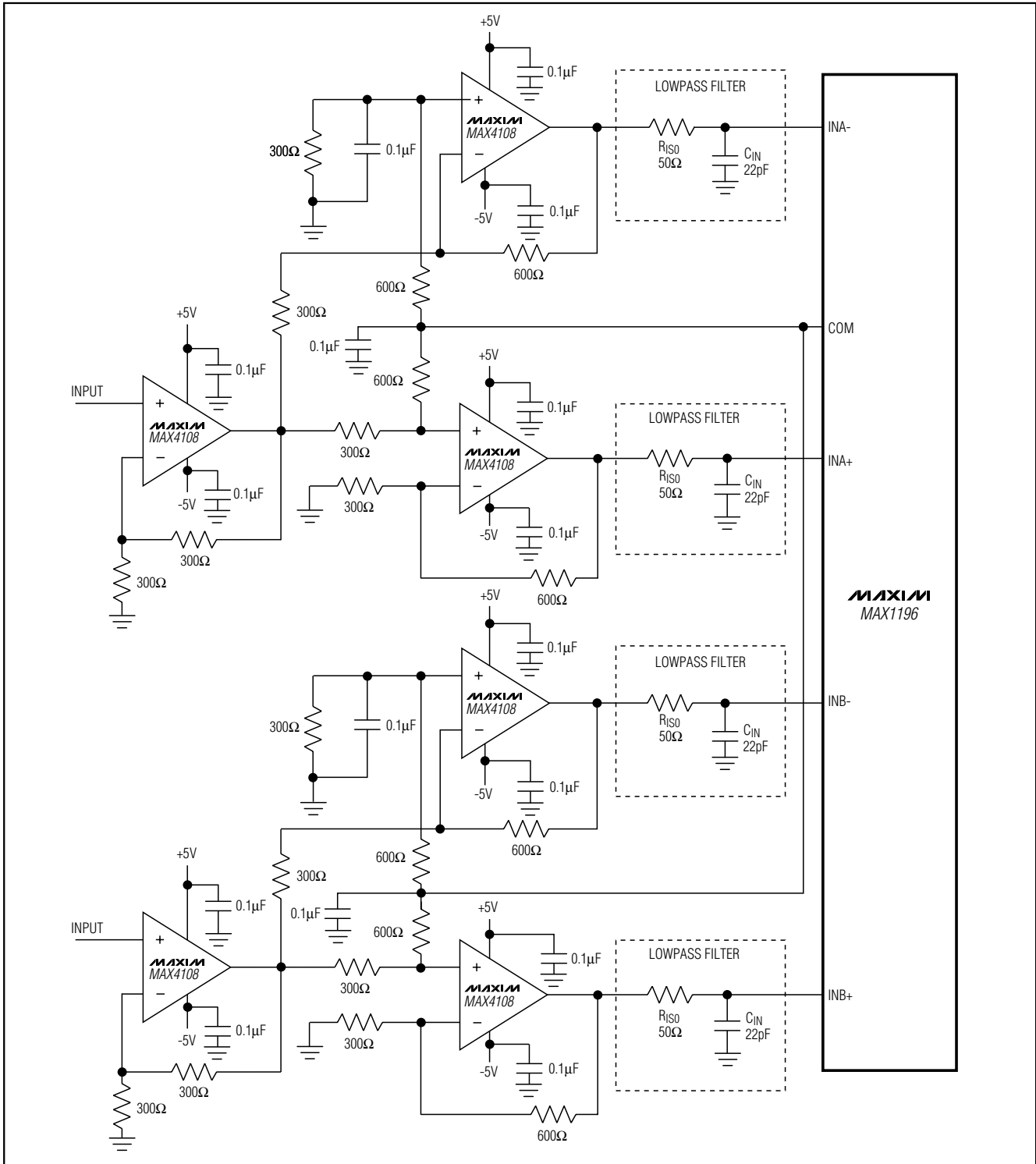

Figure 5. Typical Application for Single-Ended-to-Differential Conversion

Dual 8-Bit, 40MSPS, 3V, Low-Power ADC with Internal Reference and Multiplexed Parallel Outputs

MAX1196

In general, the MAX1196 provides better SFDR and THD with fully differential input signals than single-ended drive, especially for very high input frequencies. In differential input mode, even-order harmonics are lower as both inputs (INA+, INA- and/or INB+, INB-) are balanced, and each of the ADC inputs only requires half the signal swing compared to single-ended mode.

Single-Ended AC-Coupled Input Signal

Figure 7 shows an AC-coupled, single-ended application. Amplifiers like the MAX4108 provide high speed, high bandwidth, low noise, and low distortion to maintain the integrity of the input signal.

Buffered External Reference Drives Multiple ADCs

Multiple-converter systems based on the MAX1196 are well suited for use with a common reference voltage. The REFIN pin of those converters can be connected directly to an external reference source.

A precision bandgap reference like the MAX6062 generates an external DC level of 2.048V (Figure 8), and exhibits a noise voltage density of 150nV/√Hz. Its output passes through a one-pole lowpass filter (with 10Hz cutoff frequency) to the MAX4250, which buffers the reference before its output is applied to a second 10Hz lowpass filter. The MAX4250 provides a low offset voltage (for high gain accuracy) and a low noise level. The passive 10Hz filter following the buffer attenuates noise

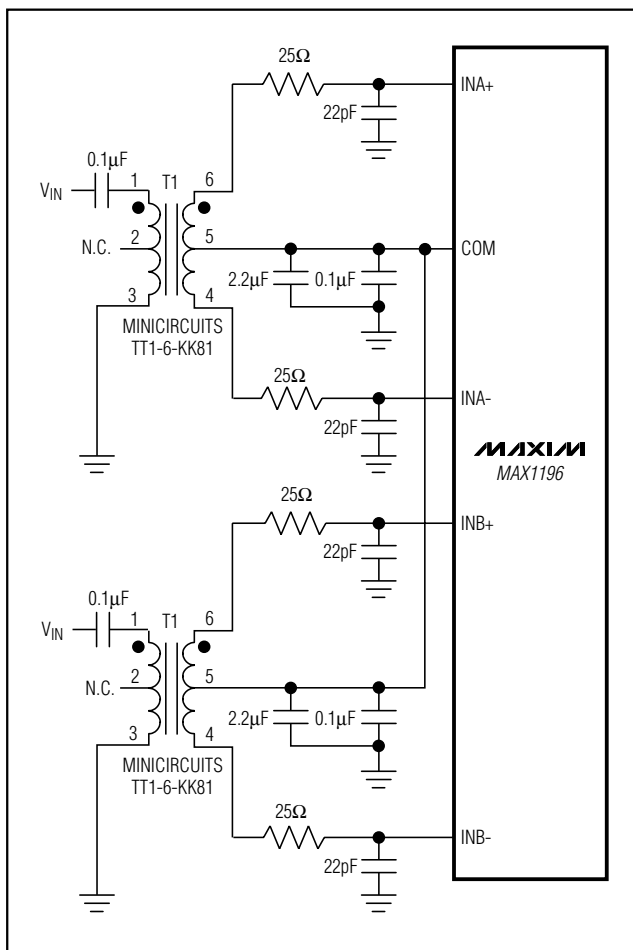

Figure 6. Transformer-Coupled Input Drive

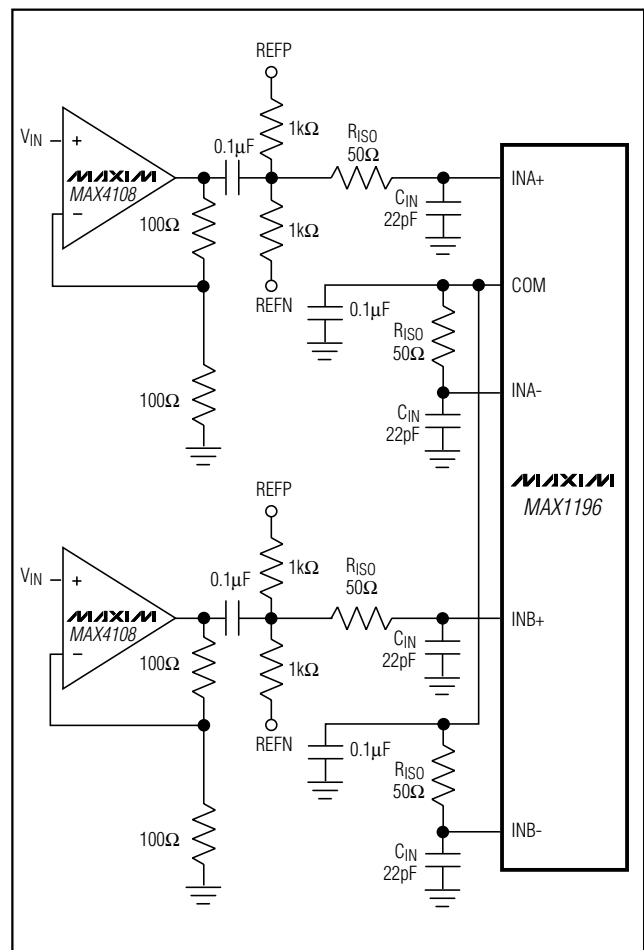

Figure 7. Using an Op Amp for Single-Ended, AC-Coupled Input Drive

Dual 8-Bit, 40MSPS, 3V, Low-Power ADC with Internal Reference and Multiplexed Parallel Outputs

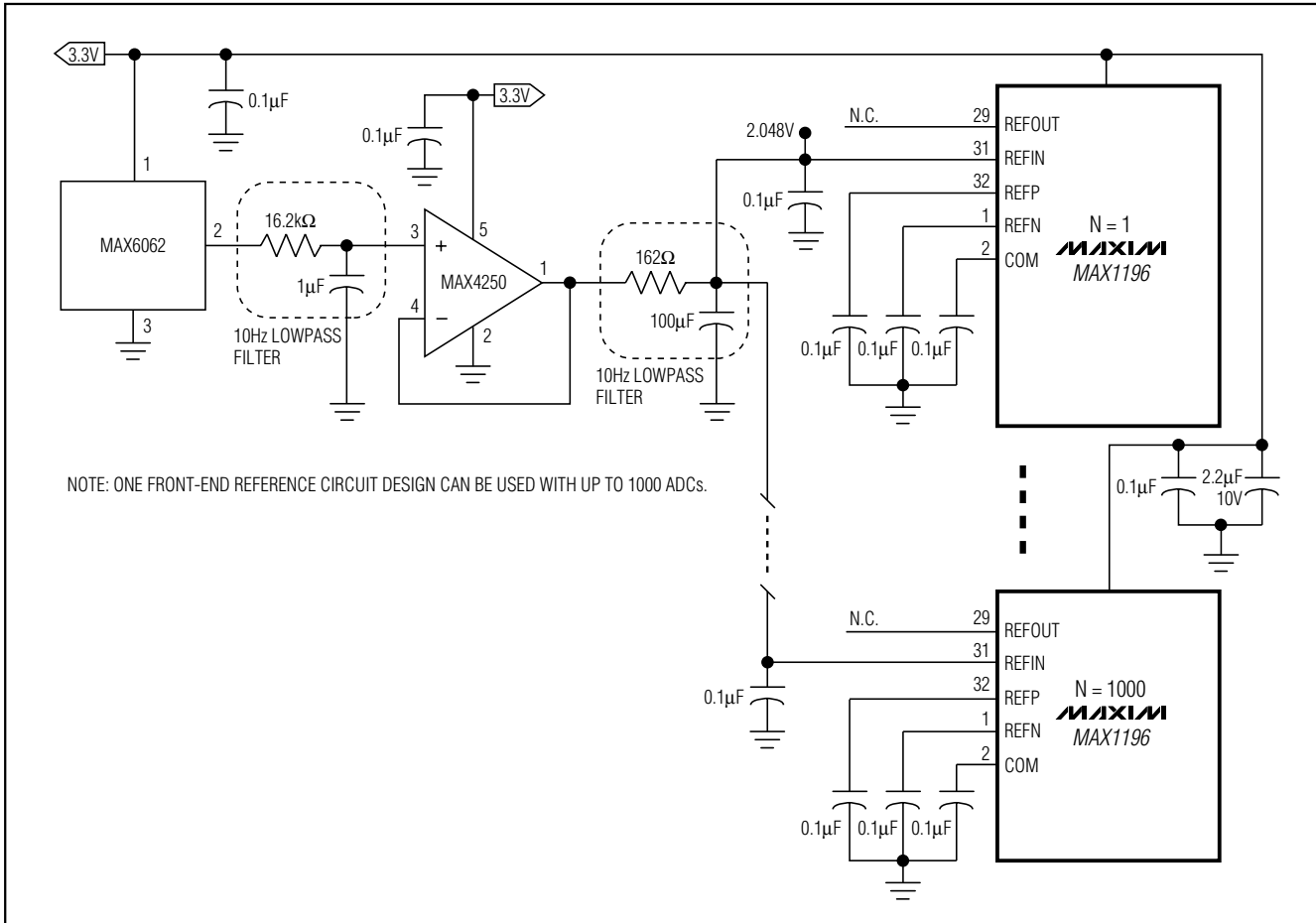

Figure 8. External Buffered (MAX4250) Reference Drive Using a MAX6062 Bandgap Reference

produced in the voltage-reference and buffer stages. This filtered noise density, which decreases for higher frequencies, meets the noise levels specified for precision-ADC operation.

Unbuffered External Reference Drives Multiple ADCs

Connecting each REFIN to analog ground disables the internal reference of each device, allowing the internal reference ladders to be driven directly by a set of external reference sources. Followed by a 10Hz lowpass filter and precision voltage-divider, the MAX6066 generates a DC level of 2.500V. The buffered outputs of this divider are set to 2.0V, 1.5V, and 1.0V, with an accuracy that depends on the tolerance of the divider resistors.

Those three voltages are buffered by the MAX4252, which provides low noise and low DC offset. The individ-

ual voltage followers are connected to 10Hz lowpass filters, which filter both the reference-voltage and amplifier noise to a level of $3\text{nV}/\sqrt{\text{Hz}}$. The 2.0V and 1.0V reference voltages set the differential full-scale range of the associated ADCs at 2V_{p-p}. The 2.0V and 1.0V buffers drive the ADCs' internal ladder resistances between them.

Note that the common power supply for all active components removes any concern regarding power-supply sequencing when powering up or down.

With the outputs of the MAX4252 matching better than 0.1%, the buffers and subsequent lowpass filters can be replicated to support as many as 32 ADCs. For applications requiring more than 32 matched ADCs, a voltage-reference and divider string common to all converters is highly recommended.

Dual 8-Bit, 40MSPS, 3V, Low-Power ADC with Internal Reference and Multiplexed Parallel Outputs

MAX1196

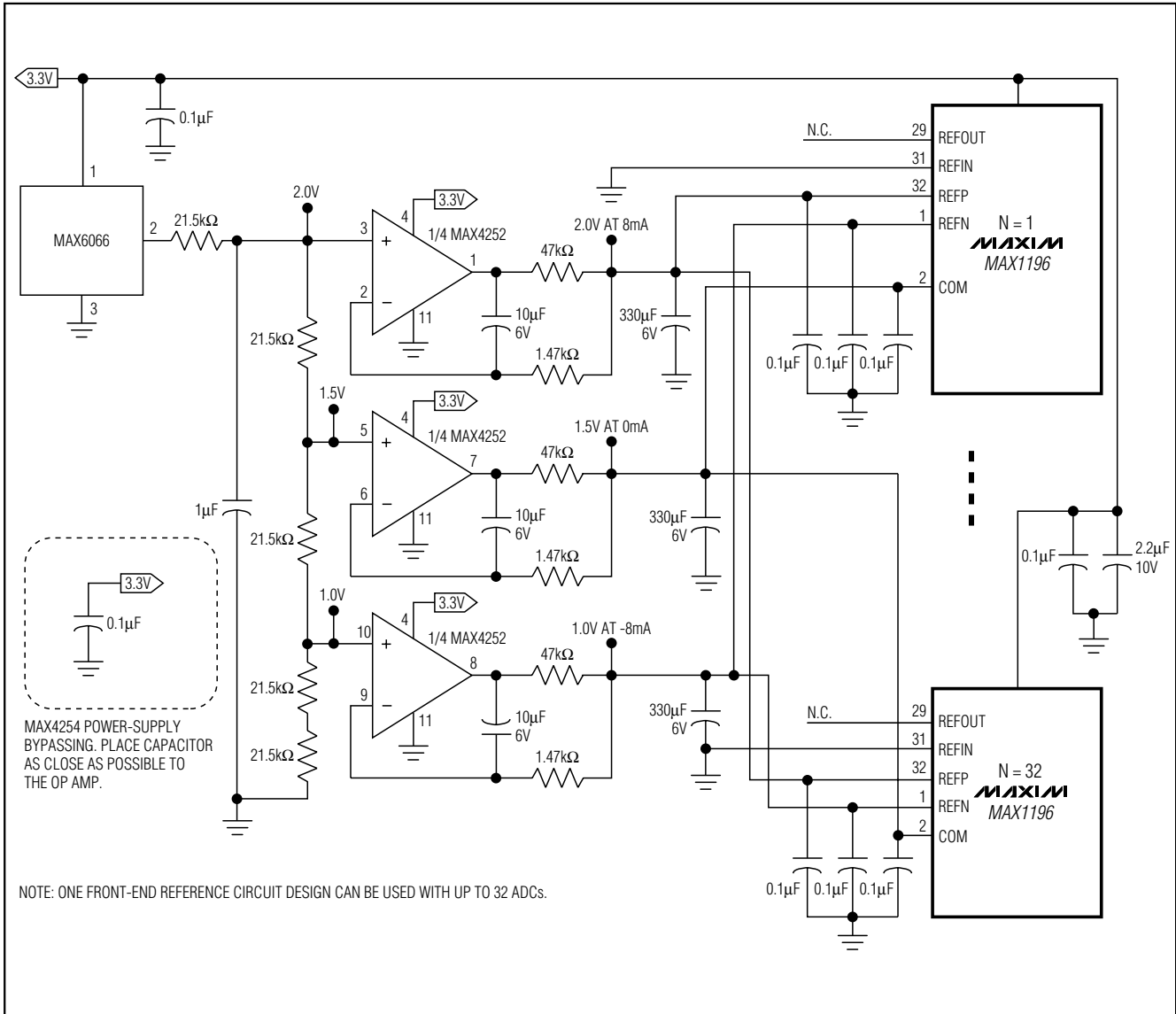

Figure 9. External Unbuffered Reference Drive With MAX4252 and MAX6066

Typical QAM Demodulation Application

A frequently used modulation technique in digital communications applications is quadrature amplitude modulation (QAM). Typically found in spread-spectrum-based systems, a QAM signal represents a carrier frequency modulated in both amplitude and phase. At the transmitter, modulating the baseband signal with quadrature outputs, a local oscillator followed by subsequent up-conversion can generate the QAM signal. The result is an in-phase (I) and a quadrature (Q) carrier

component, where the Q component is 90 degrees phase-shifted with respect to the in-phase component. At the receiver, the QAM signal is divided down into its I and Q components, essentially representing the modulation process reversed. Figure 10 displays the demodulation process performed in the analog domain, using the dual matched 3V, 8-bit ADC MAX1196, and the MAX2451 quadrature demodulator to recover and digitize the I and Q baseband signals. Before being digitized by the MAX1196, the mixed-down signal components can be filtered by matched analog filters, such

Dual 8-Bit, 40Mps, 3V, Low-Power ADC with Internal Reference and Multiplexed Parallel Outputs

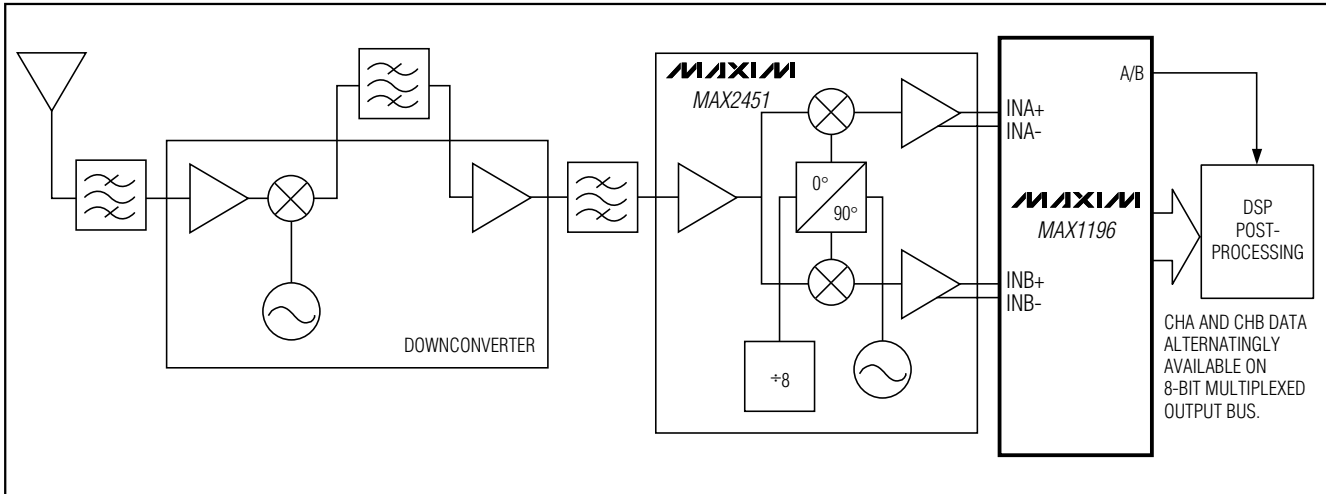

Figure 10. Typical QAM Application Using the MAX1196

as Nyquist or pulse-shaping filters, which remove unwanted images from the mixing process, thereby enhancing the overall signal-to-noise (SNR) performance and minimizing intersymbol interference.

Grounding, Bypassing, and Board Layout

The MAX1196 requires high-speed board layout design techniques. Locate all bypass capacitors as close to the device as possible, preferably on the same side as the ADC, using surface-mount devices for minimum inductance. Bypass V_{DD} , REFP, REFN, and COM with two parallel 0.1 μ F ceramic capacitors and a 2.2 μ F bipolar capacitor to GND. Follow the same rules to bypass the digital supply (OV_{DD}) to OGND. Multilayer boards with separated ground and power planes produce the highest level of signal integrity. Consider the use of a split ground plane arranged to match the physical location of the analog ground (GND) and the digital output-driver ground (OGND) on the ADC's package. The two ground planes should be joined at a single point such that the noisy digital ground currents do not interfere with the analog ground plane. The ideal location of this connection can be determined experimentally at a point along the gap between the two ground planes, which produces optimum results. Make this connection with a low-value, surface-mount resistor (1 Ω to 5 Ω), a ferrite bead, or a direct short.

Alternatively, all ground pins could share the same ground plane, if the ground plane is sufficiently isolated from any noisy, digital systems ground plane (e.g., downstream output buffer or DSP ground plane). Route

high-speed digital signal traces away from the sensitive analog traces of either channel. Make sure to isolate the analog input lines to each respective converter to minimize channel-to-channel crosstalk. Keep all signal lines short and free of 90 degree turns.

Static Parameter Definitions

Integral Nonlinearity (INL)

Integral nonlinearity is the deviation of the values on an actual transfer function from a straight line. This straight line can be either a best-straight-line fit or a line drawn between the endpoints of the transfer function, once offset and gain errors have been nullified. The static linearity parameters for the MAX1196 are measured using the best-straight-line fit method.

Differential Nonlinearity (DNL)

Differential nonlinearity is the difference between an actual step width and the ideal value of 1LSB. A DNL error specification of less than 1LSB guarantees no missing codes and a monotonic transfer function.

Dynamic Parameter Definitions

Aperture Jitter

Figure 11 depicts the aperture jitter (t_{AJ}), which is the sample-to-sample variation in the aperture delay.

Aperture Delay

Aperture delay (t_{AD}) is the time defined between the rising edge of the sampling clock and the instant when an actual sample is taken (Figure 11).

Dual 8-Bit, 40MSPS, 3V, Low-Power ADC with Internal Reference and Multiplexed Parallel Outputs

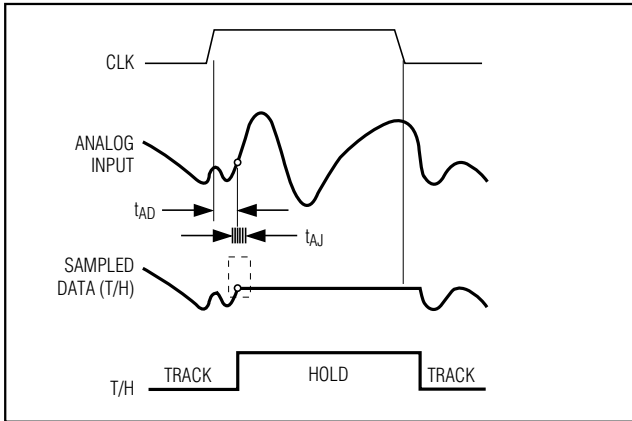

Figure 11. T/H Aperture Timing

Signal-to-Noise Ratio (SNR)

For a waveform perfectly reconstructed from digital samples, the theoretical maximum SNR is the ratio of the full-scale analog input (RMS value) to the RMS quantization error (residual error). The ideal, theoretical minimum analog-to-digital noise is caused by quantization error only and results directly from the ADC's resolution (N bits):

$$SNR_{dB[max]} = 6.02_{dB} \times N + 1.76_{dB}$$

In reality, there are other noise sources besides quantization noise: thermal noise, reference noise, clock jitter, etc. SNR is computed by taking the ratio of the RMS signal to the RMS noise, which includes all spectral components minus the fundamental, the first five harmonics, and the DC offset.

Signal-to-Noise Plus Distortion (SINAD)

SINAD is computed by taking the ratio of the RMS signal to all spectral components minus the fundamental and the DC offset.

Effective Number of Bits (ENOB)

ENOB specifies the dynamic performance of an ADC at a specific input frequency and sampling rate. An ideal ADC error consists of quantization noise only. ENOB for a full-scale sinusoidal input waveform is computed from:

$$ENOB = \left(\frac{SINAD - 1.76}{6.02} \right)$$

Total Harmonic Distortion (THD)

THD is typically the ratio of the RMS sum of the first four harmonics of the input signal to the fundamental itself. This is expressed as:

$$THD = 20 \times \log \left(\frac{\sqrt{V_2^2 + V_3^2 + V_4^2 + V_5^2}}{V_1} \right)$$

where V_1 is the fundamental amplitude, and V_2 through V_5 are the amplitudes of the 2nd- through 5th-order harmonics.

Spurious-Free Dynamic Range (SFDR)

SFDR is the ratio expressed in decibels of the RMS amplitude of the fundamental (maximum signal component) to the RMS value of the next largest spurious component, excluding DC offset.

Intermodulation Distortion (IMD)

The two-tone IMD is the ratio expressed in decibels of either input tone to the worst third-order (or higher) intermodulation products. The individual input tone levels are at -7dB full scale.

Pin-Compatible Upgrades (Sampling Speed and Resolution)

8-BIT PART	10-BIT PART	SAMPLING SPEED (MSPS)
N/A	MAX1185	20
MAX1195	MAX1183	40
MAX1197	MAX1182	60
MAX1198	MAX1180	100
N/A	MAX1190	120
MAX1196	MAX1186	40, multiplexed

Chip Information

TRANSISTOR COUNT: 11,601

PROCESS: CMOS

Dual 8-Bit, 40Mps, 3V, Low-Power ADC with Internal Reference and Multiplexed Parallel Outputs

Functional Diagram

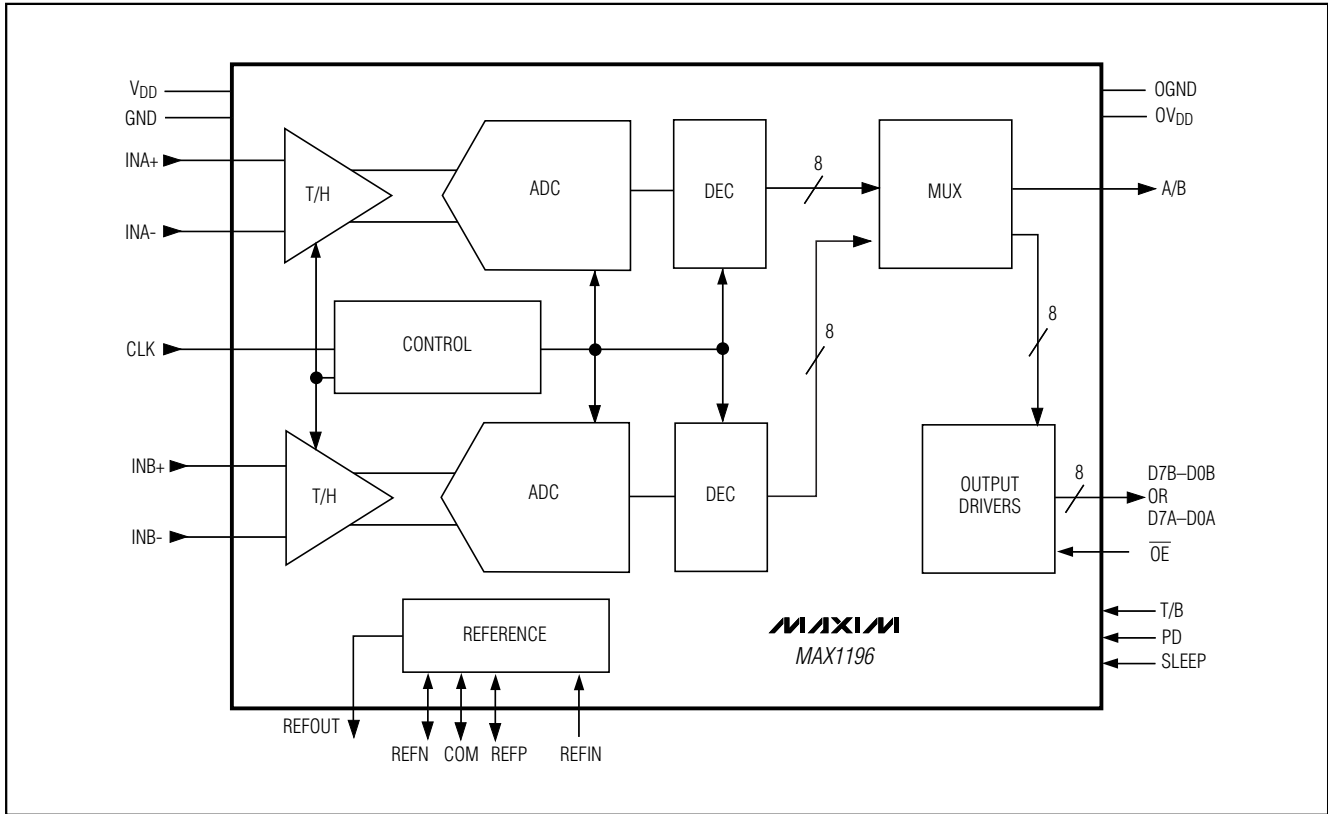

Dual 8-Bit, 40MSPS, 3V, Low-Power ADC with Internal Reference and Multiplexed Parallel Outputs

Package Information

(The package drawing(s) in this data sheet may not reflect the most current specifications. For the latest package outline information go to www.maxim-ic.com/packages.)

MAX1196

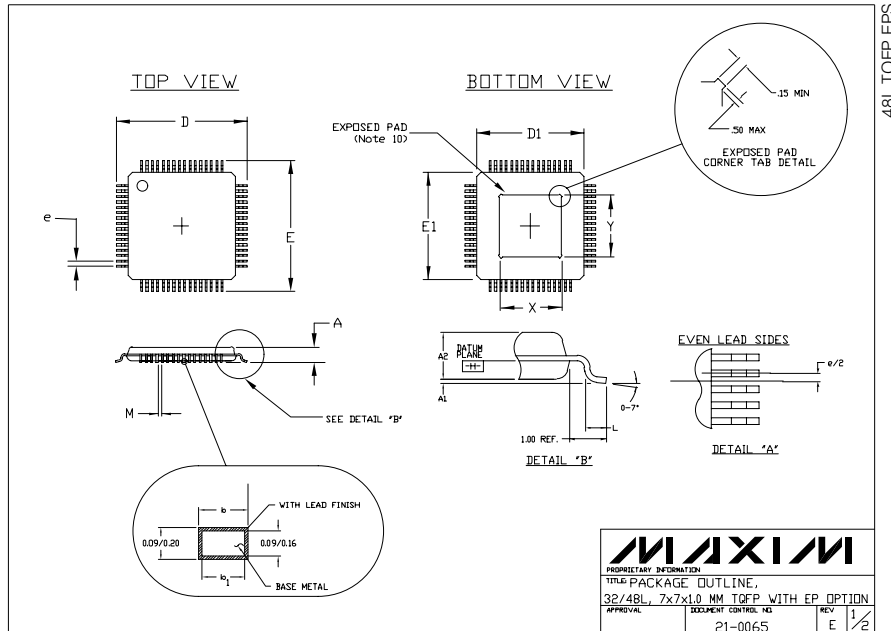

NOTES:

- ALL DIMENSIONS AND TOLERANCING CONFORM TO ANSI Y14.5-1982.
- DATUM PLANE [H] IS LOCATED AT MOLD PARTING LINE AND COINCIDENT WITH LEAD, WHERE LEAD EXISTS PLASTIC BODY AT BOTTOM OF PARTING LINE.
- DIMENSIONS D1 AND E1 DO NOT INCLUDE MOLD PROTRUSION. ALLOWABLE MOLD PROTRUSION IS 0.254 MM ON D1 AND E1 DIMENSIONS.
- THE TOP OF PACKAGE IS SMALLER THAN THE BOTTOM OF PACKAGE BY 0.15 MILLIMETERS.
- DIMENSION b DOES NOT INCLUDE DAMBAR PROTRUSION. ALLOWABLE DAMBAR PROTRUSION SHALL BE 0.08 MM TOTAL IN EXCESS OF THE b DIMENSION AT MAXIMUM MATERIAL CONDITION.
- CONTROLLING DIMENSION: MILLIMETER.
- THIS OUTLINE CONFORMS TO JEDEC PUBLICATION 95 REGISTRATION MO-136, VARIATIONS AC AND AE.
- LEADS SHALL BE COPLANAR WITHIN .004 INCH.
- EXPOSED DIE PAD SHALL BE COPLANAR WITH BOTTOM OF PACKAGE WITHIN 2 MILS (.05 MM).
- DIMENSIONS X & Y APPLY TO EXPOSED PAD (EP) VERSIONS ONLY. SEE INDIVIDUAL PRODUCT DATASHEET TO DETERMINE IF A PRODUCT USES EXPOSED PAD PACKAGE.

SYMBOL	JEDEC VARIATION ALL DIMENSIONS IN MILLIMETERS					
	AC			AE		
	MIN.	NOM.	MAX.	MIN.	NOM.	MAX.
A	~	~	1.20	~	~	1.20
A1	0.05	0.10	0.15	0.05	0.10	0.15
A2	0.95	1.00	1.05	0.95	1.00	1.05
D	9.00 BSC.			9.00 BSC.		
D1	7.00 BSC.			7.00 BSC.		
E	9.00 BSC.			9.00 BSC.		
E1	7.00 BSC.			7.00 BSC.		
L	0.45	0.60	0.75	0.45	0.60	0.75
M	0.15	~	~	0.14	~	~
N	32			48		
e	0.80 BSC.			0.50 BSC.		
b	0.30	0.37	0.45	0.17	0.22	0.27
b1	0.30	0.35	0.40	0.17	0.20	0.23
*X	3.20	3.50	3.80	3.70	4.00	4.30
*Y	3.20	3.50	3.80	3.70	4.00	4.30

* EXPOSED PAD
(Note 10)

MAXIM

PROPRIETARY INFORMATION
TITLE: PACKAGE OUTLINE,
32/48L, 7x7x1.0 MM TOFP WITH EP OPTION
APPROVAL: DOCUMENT CONTROL NO: 21-0065 REV: E 2/2

Maxim cannot assume responsibility for use of any circuitry other than circuitry entirely embodied in a Maxim product. No circuit patent licenses are implied. Maxim reserves the right to change the circuitry and specifications without notice at any time.

Maxim Integrated Products, 120 San Gabriel Drive, Sunnyvale, CA 94086 408-737-7600 _____ **23**