

MAXIM

670MHz LVDS-to-LVDS and Anything-to-LVDS 2:1 Multiplexers

MAX9176/MAX9177

General Description

The MAX9176/MAX9177 are 670MHz, low-jitter, low-skew 2:1 multiplexers ideal for protection switching, loopback, and clock distribution. The devices feature ultra-low 68ps peak-to-peak deterministic jitter that ensures reliable operation in high-speed links that are highly sensitive to timing errors.

The MAX9176 has fail-safe LVDS inputs and an LVDS output. The MAX9177 has "anything" differential inputs (CML/LVDS/LVPECL) and an LVDS output. The output can be put into high impedance using the power-down input. The MAX9176 features fail-safe circuits that drive the output high when a selected input is open, undriven and shorted, or undriven and terminated. The MAX9177 has bias circuits that force the output high when a selected input is open. The mux select and power-down inputs are compatible with standard LVTTTL/LVCMOS logic.

The select and power-down inputs tolerate undershoot of -1V and overshoot of $V_{CC} + 1V$. The MAX9176/MAX9177 are available in 10-pin μ MAX and 10-lead thin QFN packages, and operate from a single 3.3V supply over the -40°C to +85°C temperature range.

Applications

Protection Switching
Loopback
Clock Distribution

Functional Diagram appears at end of data sheet.

Features

- ◆ 1.0ps(RMS) Jitter (max) at 670MHz
- ◆ 68ps(P-P) Jitter at 800Mbps Data Rate
- ◆ 3.3V Supply
- ◆ LVDS Fail-Safe Inputs (MAX9176)
- ◆ Anything Inputs (MAX9177) Accept CML/LVDS/LVPECL
- ◆ Select and Power-Down Inputs Tolerate -1.0V and $V_{CC} + 1.0V$
- ◆ Low-Power CMOS Design
- ◆ 10-Lead μ MAX and QFN Packages
- ◆ -40°C to +85°C Operating Temperature Range
- ◆ Conform to ANSI TIA/EIA-644 LVDS Standard
- ◆ IEC61000-4-2 Level 4 ESD Rating

Ordering Information

PART	TEMP RANGE	PIN-PACKAGE
MAX9176EUB	-40°C to +85°C	10 μ MAX
MAX9176ETB*	-40°C to +85°C	10 Thin QFN-EP**
MAX9177EUB	-40°C to +85°C	10 μ MAX
MAX9177ETB*	-40°C to +85°C	10 Thin QFN-EP**

*Future product—contact factory for availability.

**EP = Exposed paddle.

Pin Configurations

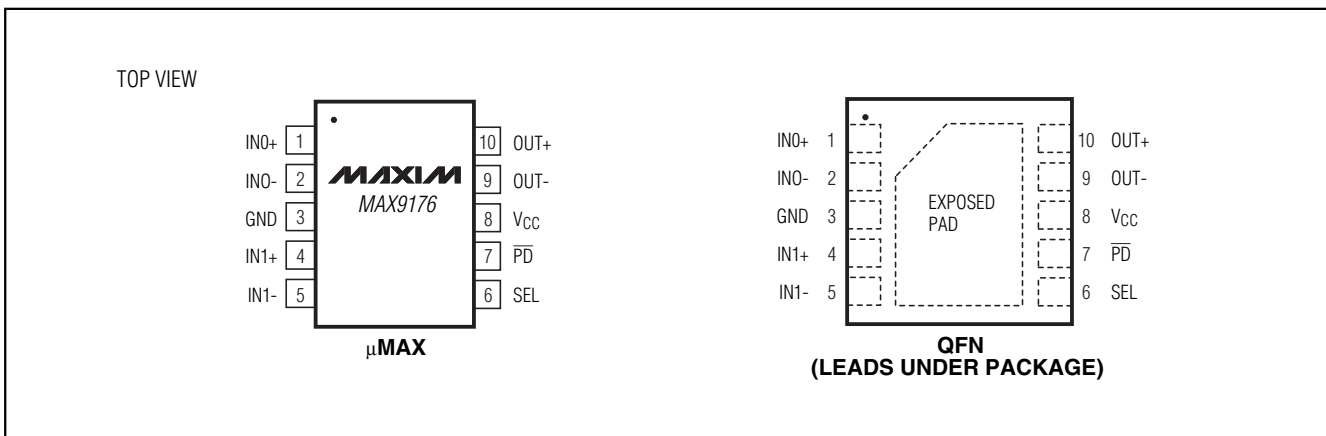

670MHz LVDS-to-LVDS and Anything-to-LVDS 2:1 Multiplexers

ABSOLUTE MAXIMUM RATINGS

V _{CC} to GND	-0.3V to +4.0V
IN ₊ , IN ₋ to GND	-0.3V to +4.0V
OUT ₊ , OUT ₋ to GND	-0.3V to +4.0V
PD, SEL to GND	-1.4V to (V _{CC} + 1.4V)
Single-Ended and Differential Output	
Short-Circuit Duration (OUT ₊ , OUT ₋)	Continuous
Continuous Power Dissipation (T _A = +70°C)	
10-Pin μMAX (derate 5.6mW/°C above +70°C)	444mW
10-Lead Thin QFN (derate 24.4mW/°C above +70°C)	1951mW

Operating Temperature Range	-40°C to +85°C
Maximum Junction Temperature	+150°C
Storage Temperature Range	-65°C to +150°C
ESD Protection	
Human Body Model (R _D = 1.5kΩ, C _S = 100pF)	
(IN ₊ , IN ₋ , OUT ₊ , OUT ₋)	±16kV
IEC61000-4-2 Level 4 (R _D = 330Ω, C _S = 150pF)	
Contact Discharge (IN ₊ , IN ₋ , OUT ₊ , OUT ₋)	±8 kV
Air-Gap Discharge (IN ₊ , IN ₋ , OUT ₊ , OUT ₋)	±15kV
Lead Temperature (soldering, 10s)	+300°C

Stresses beyond those listed under "Absolute Maximum Ratings" may cause permanent damage to the device. These are stress ratings only, and functional operation of the device at these or any other conditions beyond those indicated in the operational sections of the specifications is not implied. Exposure to absolute maximum rating conditions for extended periods may affect device reliability.

DC ELECTRICAL CHARACTERISTICS

(V_{CC} = 3.0V to 3.6V, R_L = 100Ω, $\overline{\text{PD}}$ = high, SEL = high or low, differential input voltage |V_{ID}| = 0.05V to 1.2V, MAX9176 input common-mode voltage V_{CM} = |V_{ID}|/2 to 2.4V - |V_{ID}|/2, MAX9177 input common-mode voltage V_{CM} = |V_{ID}|/2 to V_{CC} - |V_{ID}|/2, T_A = -40°C to +85°C, unless otherwise noted. Typical values are at V_{CC} = 3.3V, |V_{ID}| = 0.2V, V_{CM} = 1.25V, T_A = +25°C.) (Notes 1, 2, 3)

PARAMETER	SYMBOL	CONDITIONS		MIN	TYP	MAX	UNITS
DIFFERENTIAL INPUTS (IN₊, IN₋)							
Differential Input High Threshold	V _{TH}					+50	mV
Differential Input Low Threshold	V _{TL}			-50			mV
Input Current	I _{IN+} , I _{IN-}	Figure 1		-20		+20	μA
Power-Off Input Current	I _{INO+} , I _{INO-}	MAX9176	V _{CC} = 0 or open, Figure 1				
		MAX9177	V _{IN+} = 3.6V or 0, V _{IN-} = 3.6V or 0, V _{CC} = 0 or open, Figure 1	-20		+20	μA
Fail-Safe Input Resistors (MAX9176)	R _{IN1}	V _{CC} = 3.6V, 0 or open, Figure 1		60		108	kΩ
	R _{IN2}			200		394	
Input Resistors (MAX9177)	R _{IN3}	V _{CC} = 3.6V, 0 or open, Figure 1		212		450	kΩ
Input Capacitance	C _{IN}	IN ₊ or IN ₋ to GND (Note 4)				4.5	pF
LVTTTL/LVCMOS INPUTS (SEL, PD)							
Input High Voltage	V _{IH}			2.0		V _{CC} + 1.0	V
Input Low Voltage	V _{IL}			-1.0		+0.8	V
Input Current	I _{IN}	-1.0V ≤ SEL, $\overline{\text{PD}}$ ≤ 0V		-1.5			mA
		0V ≤ SEL, $\overline{\text{PD}}$ ≤ V _{CC}		-20		+20	μA
		V _{CC} ≤ SEL, $\overline{\text{PD}}$ ≤ V _{CC} + 1.0V				+1.5	mA
LVDS OUTPUT (OUT₊, OUT₋)							
Differential Output Voltage	V _{OD}	Figure 2		250	393	475	mV
Change in Differential Output Voltage Between Logic States	ΔV _{OD}	Figure 2			1.0	15	mV
Offset Voltage	V _{OS}	Figure 3		1.125	1.25	1.375	V

670MHz LVDS-to-LVDS and Anything-to-LVDS 2:1 Multiplexers

MAX9176/MAX9177

DC ELECTRICAL CHARACTERISTICS (continued)

($V_{CC} = 3.0V$ to $3.6V$, $R_L = 100\Omega$, $\overline{PD} = \text{high}$, $SEL = \text{high or low}$, differential input voltage $|V_{ID}| = 0.05V$ to $1.2V$, MAX9176 input common-mode voltage $V_{CM} = |V_{ID}|/2$ to $2.4V - |V_{ID}|/2$, MAX9177 input common-mode voltage $V_{CM} = |V_{ID}|/2$ to $V_{CC} - |V_{ID}|/2$, $T_A = -40^\circ C$ to $+85^\circ C$, unless otherwise noted. Typical values are at $V_{CC} = 3.3V$, $|V_{ID}| = 0.2V$, $V_{CM} = 1.25V$, $T_A = +25^\circ C$.) (Notes 1, 2, 3)

PARAMETER	SYMBOL	CONDITIONS		MIN	TYP	MAX	UNITS
Change in Offset Voltage Between Logic States	ΔV_{OS}	Figure 3			4	15	mV
Fail-Safe Differential Output Voltage (MAX9176)	V_{OD}	Figure 2		250	393	475	mV
Differential Output Resistance	R_{DIFF}	$V_{CC} = 3.6V$ or 0		95	123	146	Ω
Power-Down Single-Ended Output Current	I_{PD}	$\overline{PD} = \text{low}$	$V_{OUT+} = \text{open}, V_{OUT-} = 3.6V$ or 0	-1.0	± 0.01	+1.0	μA
			$V_{OUT-} = \text{open}, V_{OUT+} = 3.6V$ or 0				
Power-Off Single-Ended Output Current	I_{OFF}	$\overline{PD}, SEL = \text{low}, V_{CC} = 0$ or open	$V_{OUT+} = \text{open}, V_{OUT-} = 3.6V$ or 0	-1.0	± 0.01	+1.0	μA
			$V_{OUT-} = \text{open}, V_{OUT+} = 3.6V$ or 0				
Output Short-Circuit Current	I_{OS}	$V_{ID} = +50mV$ or $-50mV$, $V_{OUT+} = 0$ or V_{CC}		-15		+15	mA
		$V_{ID} = +50mV$ or $-50mV$, $V_{OUT-} = 0$ or V_{CC}					
Differential Output Short-Circuit Current Magnitude	I_{OSD}	$V_{ID} = +50mV$ or $-50mV$, $V_{OD} = 0$ (Note 4)				15	mA
Supply Current	I_{CC}	$R_L = 100\Omega$, $\overline{PD} = V_{CC}$, $SEL = V_{CC}$ or 0			26	40	mA
Power-Down Supply Current	I_{CCPD}	$R_L = 100\Omega$, $\overline{PD} = 0$, other inputs open			0.5	20	μA
Output Capacitance	C_O	OUT+ or OUT- to GND (Note 4)				5.2	pF

670MHz LVDS-to-LVDS and Anything-to-LVDS 2:1 Multiplexers

AC ELECTRICAL CHARACTERISTICS

($V_{CC} = 3.0V$ to $3.6V$, $R_L = 100\Omega$, $C_L = 5pF$, differential input voltage $|V_{ID}| = 0.15V$ to $1.2V$, MAX9176 input common-mode voltage $V_{CM} = |V_{ID}|/2$ to $2.4V - |V_{ID}|/2$, MAX9177 input common-mode voltage $V_{CM} = |V_{ID}|/2$ to $V_{CC} - |V_{ID}|/2$, $T_A = -40^\circ C$ to $+85^\circ C$, unless otherwise noted. Typical values are at $V_{CC} = 3.3V$, $|V_{ID}| = 0.2V$, $V_{CM} = 1.25V$, $T_A = +25^\circ C$.) (Notes 5, 6, 7)

PARAMETER	SYMBOL	CONDITIONS	MIN	TYP	MAX	UNITS
DIFFERENTIAL INPUTS (IN₊, IN₋)						
High-to-Low Propagation Delay	t _{PHL}	Figures 4, 5	1.33	2.46	3.23	ns
Low-to-High Propagation Delay	t _{PLH}	Figures 4, 5	1.33	2.49	3.31	ns
Added Deterministic Jitter	t _{DJ}	Figures 4, 5 (Notes 8, 12)		68	80	ps(P-P)
Added Random Jitter	t _{RJ}	Figures 4, 5 (Note 12)		0.7	1.0	ps(RMS)
Pulse Skew t _{PLH} - t _{PHL}	t _{SKP}	Figures 4, 5		27	142	ps
Part-to-Part Skew	t _{SKPP1}	Figures 4, 5 (Note 9)		0.4	1.3	ns
	t _{SKPP2}	Figures 4, 5 (Note 10)			2.0	
Rise Time	t _R	Figures 4, 5	217	320	383	ps
Fall Time	t _F	Figures 4, 5	157	340	360	ps
Select to Out Delay	t _{PSO}	Figure 6		2.0	2.7	ns
Power-Down Time	t _{PD}	Figures 7, 8			6.0	ns
Power-Up Time	t _{PU}	Figures 7, 8			35	μs
Maximum Data Rate	DR _{MAX}	Figures 4, 5, V _{OD} \geq 250mV (Note 11)	800			Mbps
Maximum Switching Frequency	f _{MAX}	Figures 4, 5, V _{OD} \geq 250mV (Note 11)	670			MHz
Switching Supply Current	I _{CCSW}	f _{IN} = 670MHz		38	58	mA
		f _{IN} = 155MHz		26	47	
PRBS Supply Current	I _{CCPR}	DR = 800Mbps, 2 ²³ - 1 PRBS input		27	49	mA

Note 1: Current into a pin is defined as positive. Current out of a pin is defined as negative. All voltages are referenced to ground except V_{TH} , V_{TL} , V_{ID} , V_{OD} , and ΔV_{OD} .

Note 2: Maximum and minimum limits over temperature are guaranteed by design and characterization. Devices are 100% tested at $T_A = +25^\circ C$.

Note 3: Tolerance on all external resistors (including figures) is $\pm 1\%$.

Note 4: Guaranteed by design and characterization.

Note 5: AC parameters are guaranteed by design and characterization and not production tested. Limits are set at ± 6 sigma.

Note 6: C_L includes scope probe and test jig capacitance.

Note 7: Pulse-generator output for differential inputs IN₊, IN₋ (unless otherwise noted): $f = 670MHz$, 50% duty cycle, $R_O = 50\Omega$, $t_R = 500ps$, and $t_F = 500ps$ (0% to 100%). Pulse-generator output for single-ended inputs PD, SEL: $t_R = t_F = 1.5ns$ (0.2V_{CC} to 0.8V_{CC}), 50% duty cycle, $V_{OH} = V_{CC} + 1.0V$ settling to V_{CC} , $V_{OL} = -1.0V$ settling to zero.

Note 8: Pulse-generator output for t_{DJ}: $V_{OD} = 0.15V$, $V_{OS} = 1.25V$, bit rate = 800Mbps, 2²³ - 1 PRBS, $R_O = 50\Omega$, $t_R = 500ps$, and $t_F = 500ps$ (0% to 100%).

Note 9: t_{SKPP1} is the magnitude of the difference of any differential propagation delays between devices operating under identical conditions.

Note 10: t_{SKPP2} is the magnitude of the difference of any differential propagation delays between devices operating over rated conditions.

Note 11: Meets all AC specifications.

Note 12: Input jitter subtracted from output jitter.

670MHz LVDS-to-LVDS and Anything-to-LVDS 2:1 Multiplexers

MAX9176/MAX9177

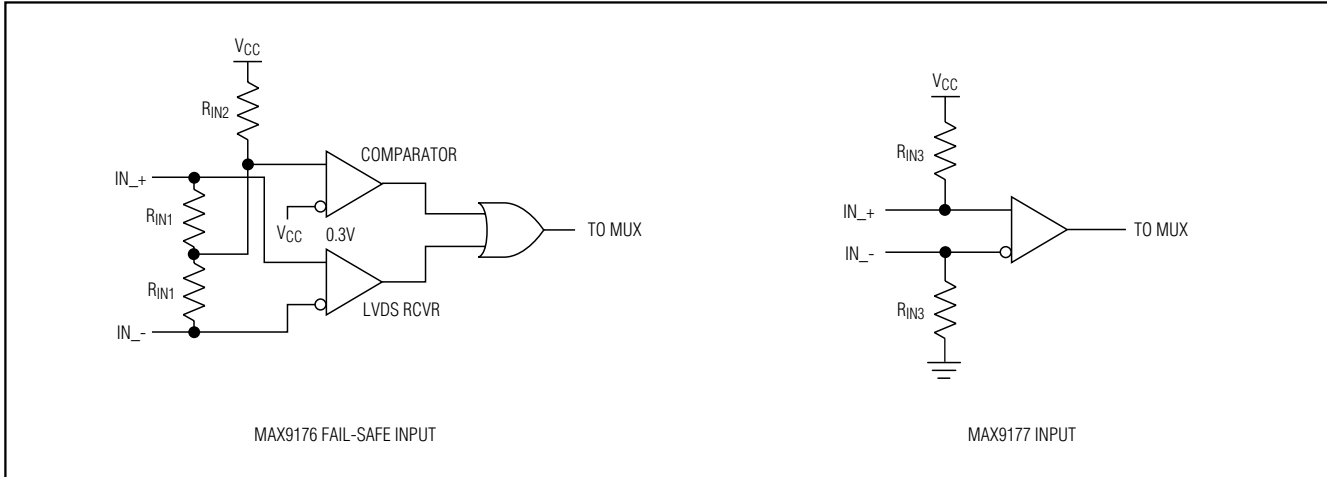

Figure 1. Input Structure

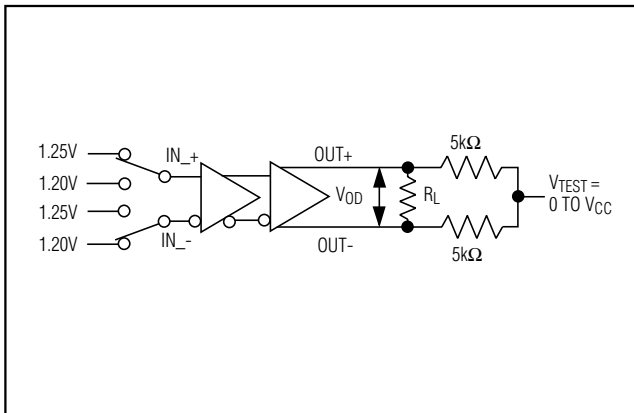

Figure 2. V_{OD} Test Circuit

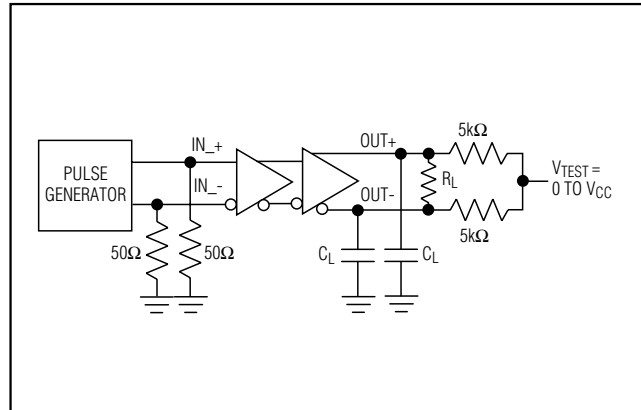

Figure 4. Transition Time and Propagation Delay Test Circuit

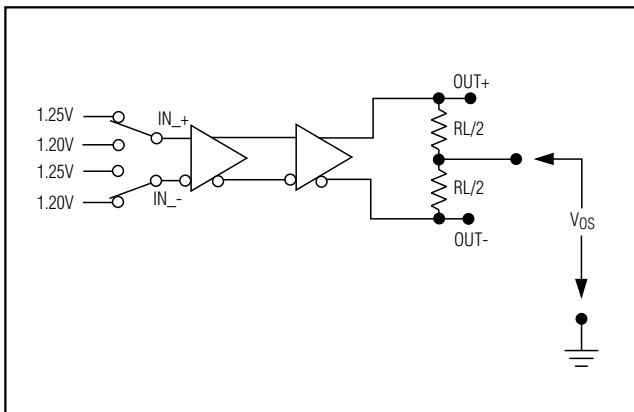

Figure 3. V_{OS} Test Circuit

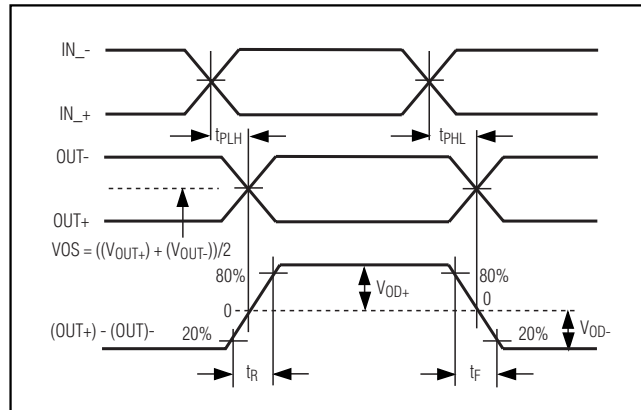

Figure 5. Transition Time and Propagation Delay Timing

670MHz LVDS-to-LVDS and Anything-to-LVDS 2:1 Multiplexers

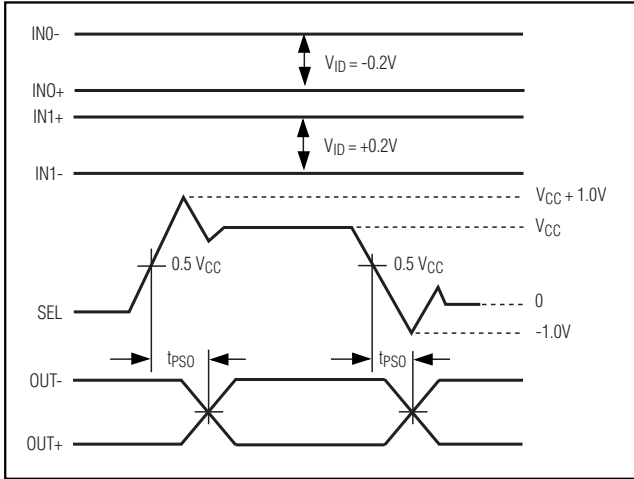

Figure 6. Select-to-Out Delay Timing

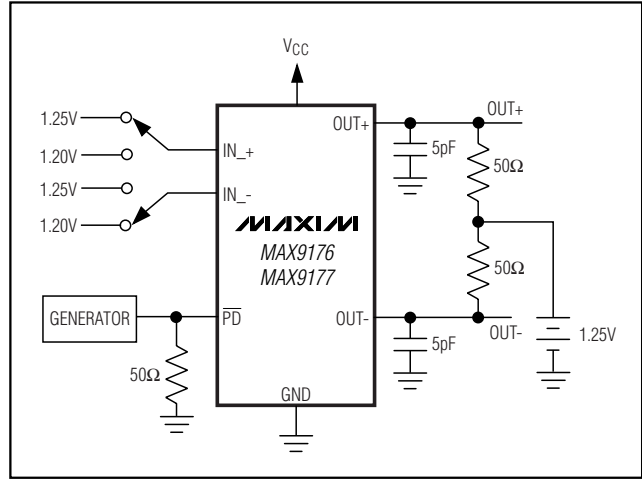

Figure 7. Power-Up/Down Delay Test Circuit

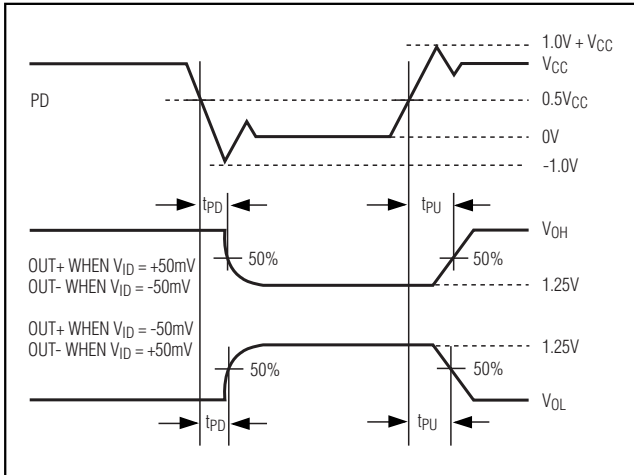

Figure 8. Power-Up/Down Delay Waveform

670MHz LVDS-to-LVDS and Anything-to-LVDS 2:1 Multiplexers

Typical Operating Characteristics

((MAX9176) $V_{CC} = 3.3V$, $|V_{ID}| = 0.2V$, $V_{CM} = 1.25V$, $R_L = 100\Omega$, $C_L = 5pf$, $\overline{PD} = V_{CC}$, $SEL = 0V$, $IN1+$, $IN1-$ = open, $T_A = +25^\circ C$, unless otherwise noted.)

MAX9176/MAX9177

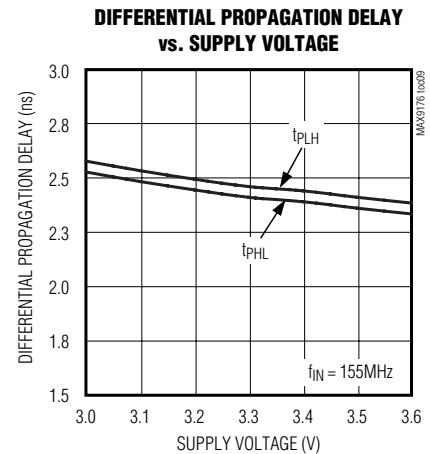
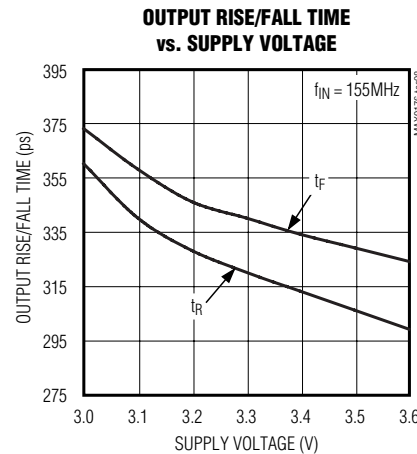
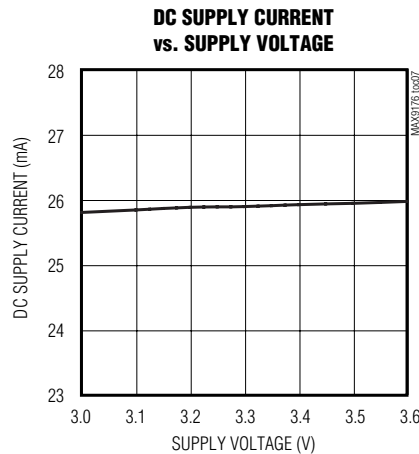
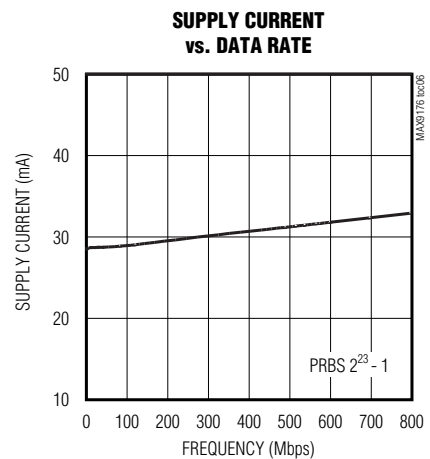
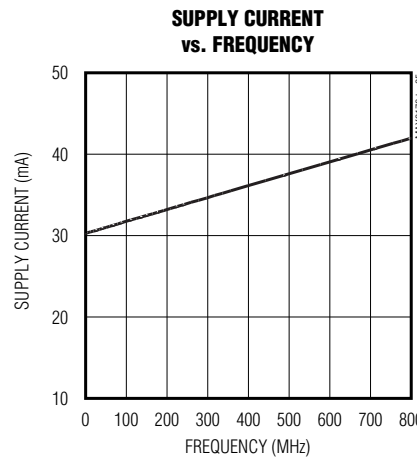
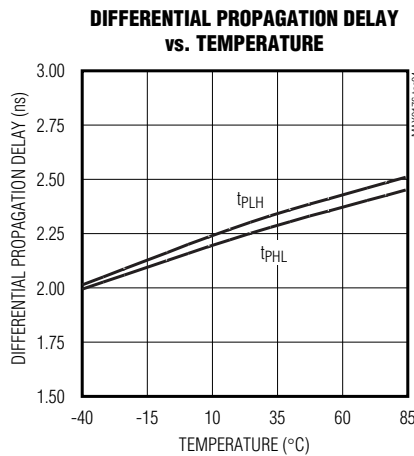
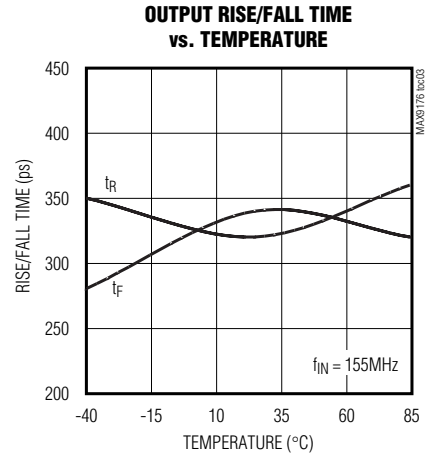
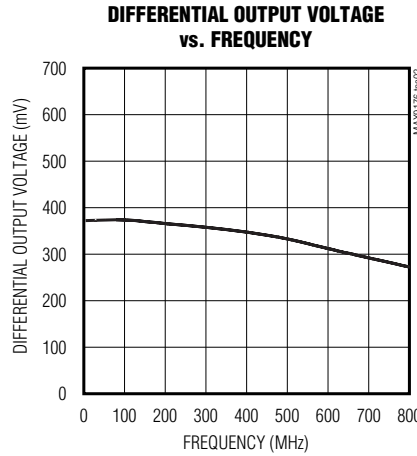
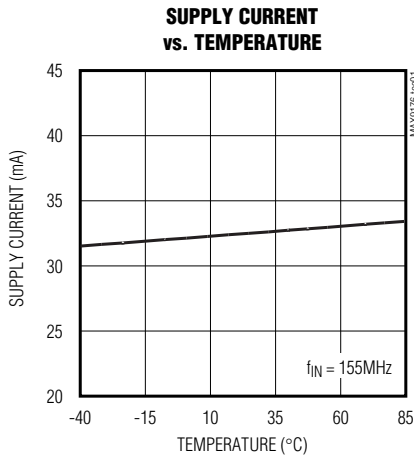

670MHz LVDS-to-LVDS and Anything-to-LVDS 2:1 Multiplexers

Typical Operating Characteristics (continued)

((MAX9176) $V_{CC} = 3.3V$, $|V_{ID}| = 0.2V$, $V_{CM} = 1.25V$, $R_L = 100\Omega$, $C_L = 5pf$, $\overline{PD} = V_{CC}$, $SEL = 0V$, $IN1+$, $IN1-$ = open, $T_A = +25^\circ C$, unless otherwise noted.)

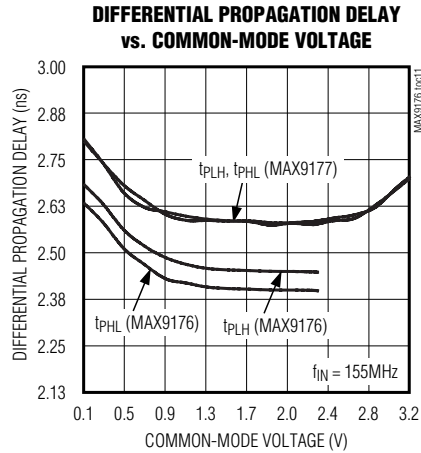
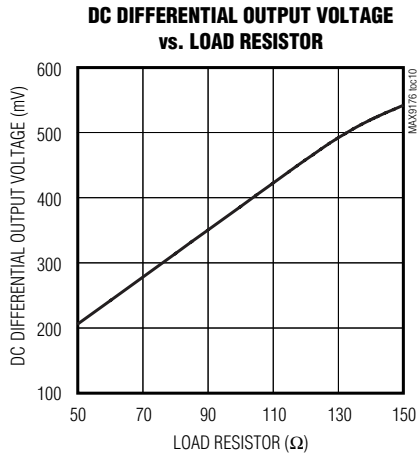

Pin Description

PIN		NAME	FUNCTION
μ MAX	QFN		
1	1	INO+	Noninverting Differential Input 0
2	2	INO-	Inverting Differential Input 0
3	3	GND	Ground
4	4	IN1+	Noninverting Differential Input 1
5	5	IN1-	Inverting Differential Input 1
6	6	SEL	LVTTL/LVCMOS Input Select. SEL = high selects differential input 1. SEL = low selects differential input 0. Internal pull-down resistor to GND.
7	7	\overline{PD}	LVTTL/LVCMOS Input. Device is powered down when \overline{PD} is low. Internal pull-down resistor to GND.
8	8	V_{CC}	Power Supply
9	9	OUT-	Inverting Differential Output
10	10	OUT+	Noninverting Differential Output
—	EP	Exposed Pad	Exposed Pad. Solder to ground.

670MHz LVDS-to-LVDS and Anything-to-LVDS 2:1 Multiplexers

Table 1. Function Table

INPUTS		OUTPUT
(IN ₊) - (IN ₋)		(OUT ₊) - (OUT ₋)
≥ +50mV		H
≤ -50mV		L
-50mV < V _{ID} < +50mV		Indeterminate
MAX9177	Open	H
MAX9176	Open, undriven short, or undriven parallel termination	

Detailed Description

The MAX9176/MAX9177 are 670MHz, low-jitter, low-skew 2:1 multiplexers ideal for protection switching, loopback, and clock distribution. The devices feature ultra-low 68ps(p-p) deterministic jitter that ensures reliable operation in high-speed links that are highly sensitive to timing error.

The MAX9176 has fail-safe LVDS inputs and an LVDS output. The MAX9177 has anything differential inputs (CML/LVDS/LVPECL) and an LVDS output. The output can be put into high impedance using the power-down input. The MAX9176 features fail-safe circuits that drive the output high when a selected input is open, undriven and shorted, or undriven and terminated. The MAX9177 has bias circuits that force the output high when a selected input is open. The mux select and power-down inputs are compatible with standard LVTTTL/LVCMOS logic.

The select and power-down inputs tolerate undershoot of -1V and overshoot of V_{CC} + 1V. The MAX9176/MAX9177 are available in 10-pin μ MAX and 10-lead thin QFN packages, and operate from a single 3.3V supply over the -40°C to +85°C temperature range.

Current-Mode LVDS Output

The LVDS output uses a current-steering configuration. This approach results in less ground bounce and less output ringing, enhancing noise margin and system speed performance.

A differential output voltage is produced by steering current through the parallel combination of the integrated differential output resistor and transmission line impedance/termination resistor. When driving a 100 Ω load, a differential voltage of 250mV to 475mV is produced. For loads greater than 100 Ω , the output voltage is larger, and for loads less than 100 Ω , the output volt-

Table 2. Input Select and Power-Down Function Table

SEL	$\overline{\text{PD}}$	OUT ₊ , OUT ₋
H	H	IN1 ₊ , IN1 ₋
L or open	H	IN0 ₊ , IN0 ₋
X	L or open	High impedance to ground and 123 Ω (typ) differential output resistance

age is smaller. See the Differential Output Voltage vs. Load Resistance curve in *Typical Operating Characteristics* for more information. The output is short-circuit current limited for single-ended and differential shorts.

MAX9176 Input Fail-Safe

The fail-safe feature of the MAX9176 sets the output high when the differential input is:

- Open
- Undriven and shorted
- Undriven and terminated

Without a fail-safe circuit, when the selected input is undriven, noise at the input may switch the output and it may appear to the system that data is being sent. Open or undriven terminated input conditions can occur when a cable is disconnected or cut, or when the driver output is in high impedance. A shorted input can occur because of a cable failure.

When the selected input is driven with a differential signal of $|V_{ID}| = 50\text{mV}$ to 1.2V within a voltage range of 0 to 2.4V, the fail-safe circuit is not activated. If the selected input is open, undriven and shorted, or undriven and terminated, an internal resistor in the fail-safe circuit pulls both inputs above V_{CC} - 0.3V, activating the fail-safe circuit and forcing the output high (Figure 1).

Overshoot and Undershoot Voltage Protection

The MAX9176/MAX9177 are designed to protect the select and power-down inputs (SEL and $\overline{\text{PD}}$) against latchup due to transient overshoot and undershoot voltage. If the input voltage goes above V_{CC} or below GND by up to 1V, an internal circuit limits input current to 1.5mA.

670MHz LVDS-to-LVDS and Anything-to-LVDS 2:1 Multiplexers

Applications Information

Power-Supply Bypassing

Bypass the V_{CC} pin with high-frequency surface-mount ceramic $0.1\mu\text{F}$ and $0.001\mu\text{F}$ capacitors in parallel as close to the device as possible, with the smaller valued capacitor closest to V_{CC} .

Differential Traces

Input and output trace characteristics affect the performance of the MAX9176/MAX9177. Use controlled-impedance differential traces (100Ω typical). To reduce radiated noise and ensure that noise couples as common mode, route the differential input and output signals within a pair close together. Reduce skew by matching the electrical length of the two signal paths that make up the differential pair. Excessive skew can result in a degradation of magnetic field cancellation. Maintain a constant distance between the differential traces to avoid discontinuities in differential impedance. Minimize the number of vias to further prevent impedance discontinuities.

Cables and Connectors

Interconnect for LVDS typically has a controlled differential impedance of 100Ω . Use cables and connectors that have matched differential impedance to minimize impedance discontinuities.

Avoid the use of unbalanced cables such as ribbon or simple coaxial cable. Balanced cables such as twisted pair offer superior signal quality and tend to generate less EMI due to magnetic field canceling effects. Balanced cables pick up noise as common mode, which is rejected by the LVDS receiver.

Termination

The MAX9176/MAX9177 require external input and output termination resistors. For LVDS, connect an input termination resistor across each differential input and at the far end of the interconnect driven by the LVDS output. Place the input termination resistor as close to the receiver input as possible. Termination resistors should match the differential impedance of the transmission line. Use 1% surface-mount resistors.

The MAX9176/MAX9177 feature an integrated differential output resistor. This resistor reduces jitter by damping reflections produced by any mismatch between the transmission line and termination resistor at the far end of the interconnect.

Board Layout

Separate the differential and single-ended signals to reduce crosstalk. A four-layer printed circuit board with separate layers for power, ground, differential signals,

and single-ended logic signals is recommended. Separate the differential signals from the logic signals with power and ground planes for best results.

IEC 61000-4-2 Level 4 ESD Protection

The IEC 61000-4-2 standard (Figure 10) specifies ESD tolerance for electronic systems. The IEC61000-4-2 model specifies a 150pF capacitor that is discharged into the device through a 330Ω resistor. The MAX9176/MAX9177 differential inputs and outputs are rated for IEC61000-4-2 level 4 ($\pm 8\text{kV}$ Contact Discharge and $\pm 15\text{kV}$ Air-Gap Discharge). The Human Body Model (HBM, Figure 9) specifies a 100pF capacitor that is discharged into the device through a $1.5\text{k}\Omega$ resistor.

IEC 61000-4-2 level 4 discharges higher peak current and more energy than the HBM due to the lower series resistance and larger capacitor.

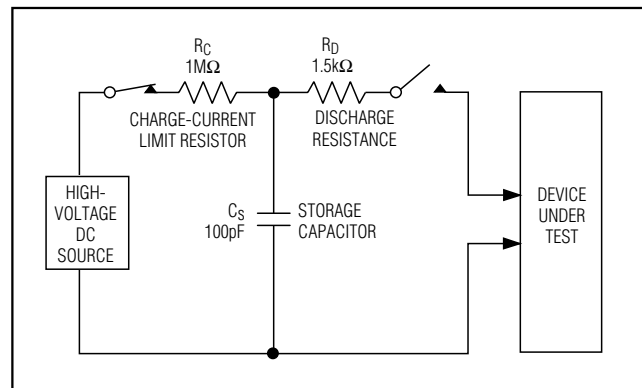

Figure 9. Human Body Test Model

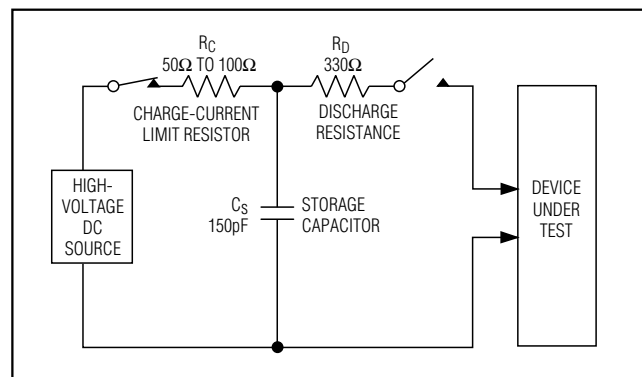
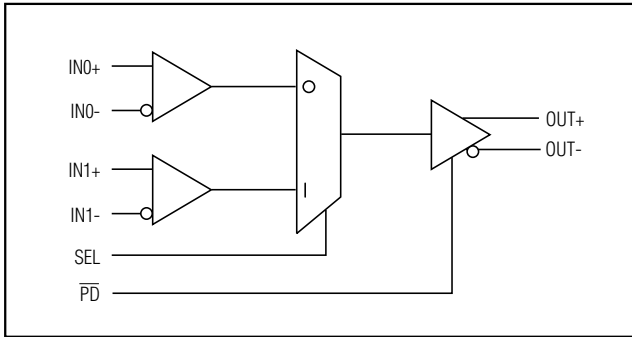

Figure 10. IEC 61000_4-2 Contact Discharge Test Model

670MHz LVDS-to-LVDS and Anything-to-LVDS 2:1 Multiplexers

Functional Diagram



Chip Information

TRANSISTOR COUNT: 744
PROCESS: CMOS

MAX9176/MAX9177

670MHz LVDS-to-LVDS and Anything-to-LVDS 2:1 Multiplexers

Package Information

(The package drawing(s) in this data sheet may not reflect the most current specifications. For the latest package outline information go to www.maxim-ic.com/packages.)

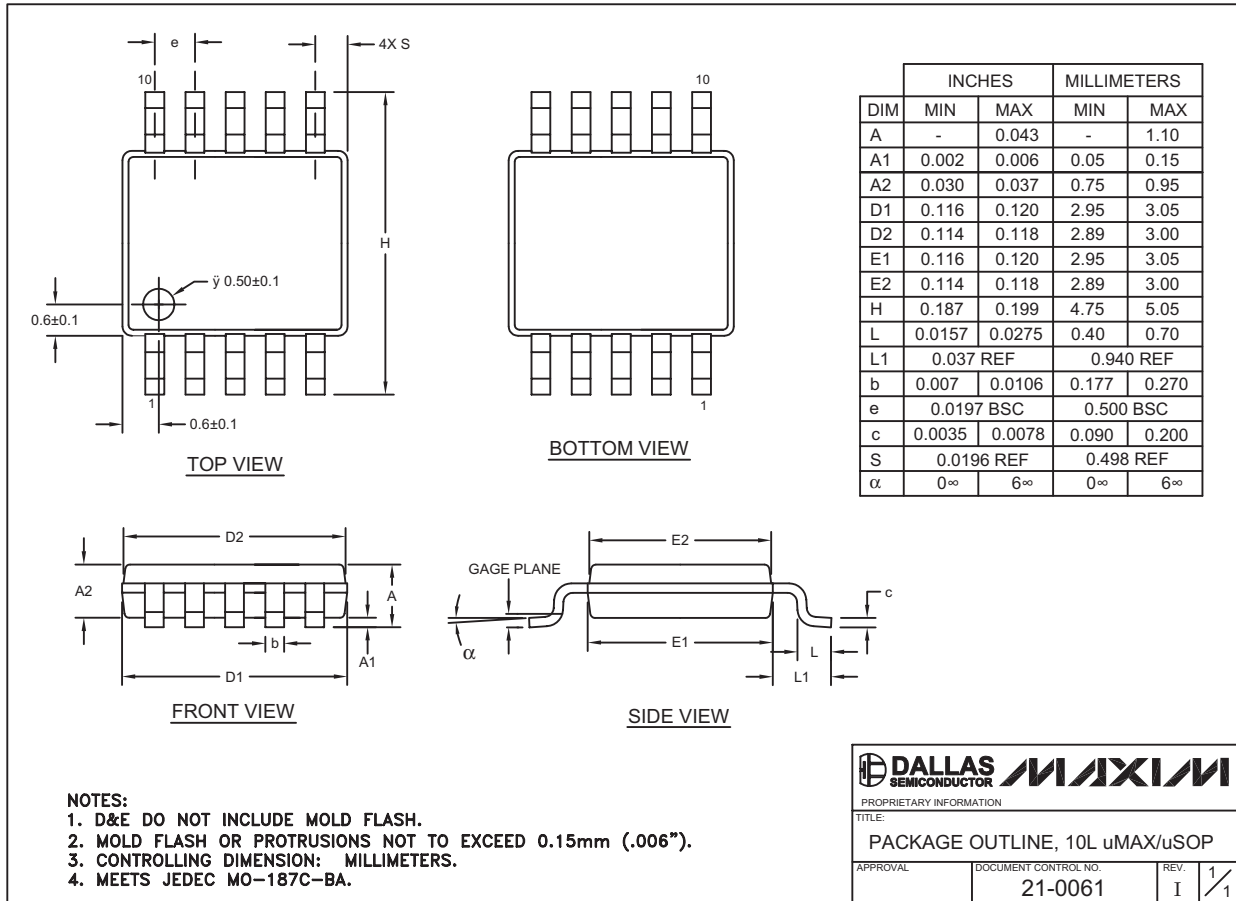

10LUMAX.EPS

670MHz LVDS-to-LVDS and Anything-to-LVDS 2:1 Multiplexers

Package Information (continued)

(The package drawing(s) in this data sheet may not reflect the most current specifications. For the latest package outline information go to www.maxim-ic.com/packages.)

MAX9176/MAX9177

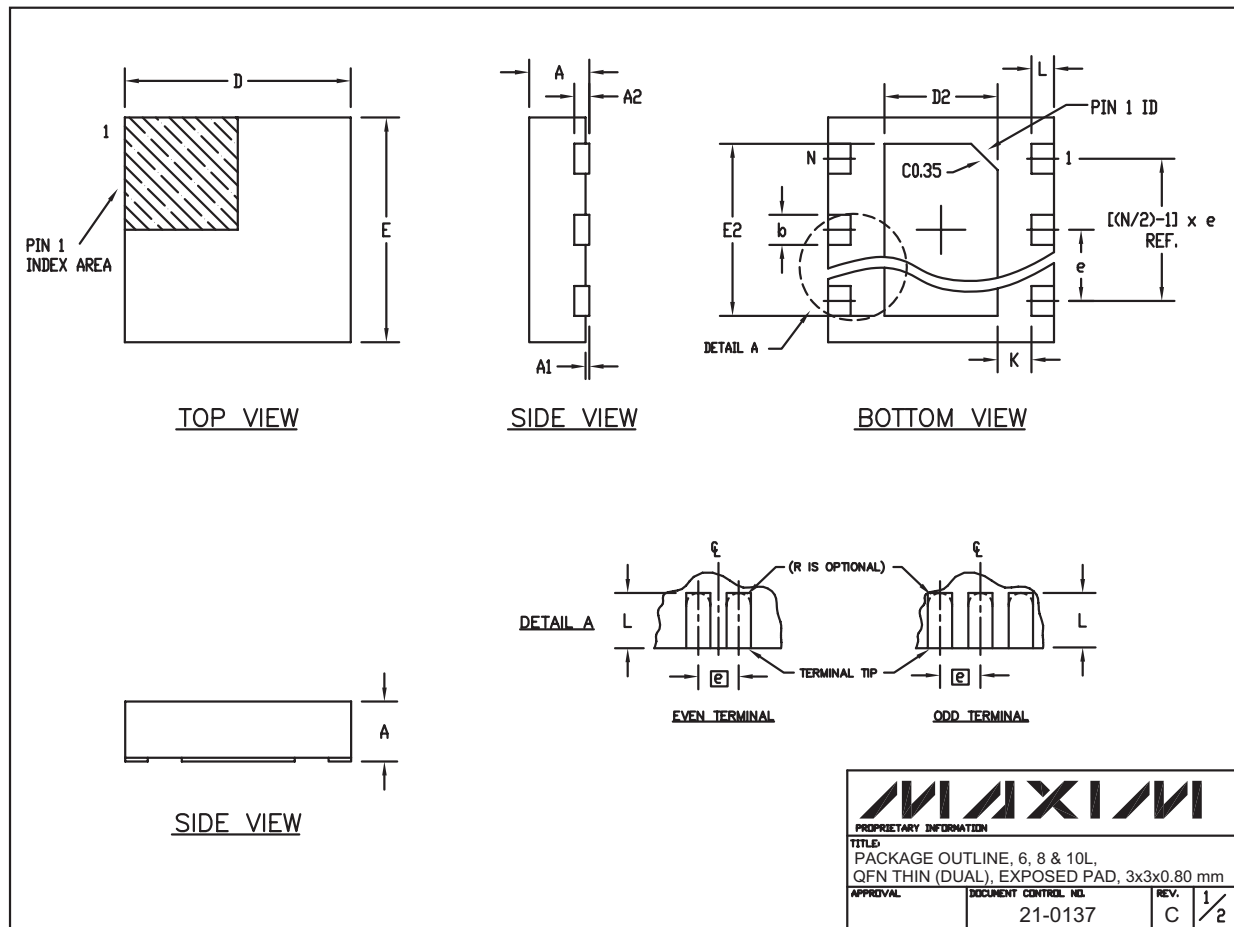

6, 8, & 10L, QFN THIN, EPS

MAXIM		
PROPRIETARY INFORMATION		
TITLE PACKAGE OUTLINE, 6, 8 & 10L, QFN THIN (DUAL), EXPOSED PAD, 3x3x0.80 mm		
APPROVAL	DOCUMENT CONTROL NO. 21-0137	REV. C 1/2

670MHz LVDS-to-LVDS and Anything-to-LVDS 2:1 Multiplexers

Package Information (continued)

(The package drawing(s) in this data sheet may not reflect the most current specifications. For the latest package outline information go to www.maxim-ic.com/packages.)

COMMON DIMENSIONS		
SYMBOL	MIN.	MAX.
A	0.70	0.80
D	2.90	3.10
E	2.90	3.10
A1	0.00	0.05
L	0.20	0.40
k	0.25 MIN	
A2	0.20 REF.	

PACKAGE VARIATIONS							
PKG. CODE	N	D2	E2	e	JEDEC SPEC	b	[(N/2)-1] x e
T633-1	6	1.50±0.10	2.30±0.10	0.95 BSC	MO229 / WEEA	0.40±0.05	1.90 REF
T833-1	8	1.50±0.10	2.30±0.10	0.65 BSC	MO229 / WEEC	0.30±0.05	1.95 REF
T1033-1	10	1.50±0.10	2.30±0.10	0.50 BSC	MO229 / WEED-3	0.25±0.05	2.00 REF

NOTES:

1. ALL DIMENSIONS ARE IN mm. ANGLES IN DEGREES.
2. COPLANARITY SHALL NOT EXCEED 0.08 mm.
3. WARPAGE SHALL NOT EXCEED 0.10 mm.
4. PACKAGE LENGTH/PACKAGE WIDTH ARE CONSIDERED AS SPECIAL CHARACTERISTIC(S).
5. DRAWING CONFORMS TO JEDEC MO220.

			
<small>PROPRIETARY INFORMATION</small>			
<small>TITLE:</small> PACKAGE OUTLINE, 6, 8 & 10L, QFN THIN (DUAL), EXPOSED PAD, 3x3x0.80 mm			
<small>APPROVAL</small>	<small>DOCUMENT CONTROL NO.</small>	<small>REV.</small>	<small>2/2</small>
	21-0137	C	

Maxim cannot assume responsibility for use of any circuitry other than circuitry entirely embodied in a Maxim product. No circuit patent licenses are implied. Maxim reserves the right to change the circuitry and specifications without notice at any time.

14 _____ **Maxim Integrated Products, 120 San Gabriel Drive, Sunnyvale, CA 94086 408-737-7600**