



## DS1995

# 16Kb Memory iButton

### SPECIAL FEATURES

- 16384 bits of read/write nonvolatile memory
- 256-bit scratchpad ensures integrity of data transfer
- Overdrive mode boosts communication to 142 kbits per second
- Memory partitioned into 256-bit pages for packetizing data
- Data integrity assured with strict read/write protocols
- Operating temperature range from -40°C to +70°C
- Over 10 years of data retention

### COMMON iButton FEATURES

- Unique, factory-lasered and tested 64-bit registration number (8-bit family code + 48-bit serial number + 8-bit CRC tester) assures absolute traceability because no two parts are alike
- Multidrop controller for MicroLAN
- Digital identification and information by momentary contact
- Chip-based data carrier compactly stores information
- Data can be accessed while affixed to object
- Economically communicates to bus master with a single digital signal at 16.3 kbits per second
- Standard 16 mm diameter and 1-Wire<sup>®</sup> protocol ensure compatibility with iButton family
- Button shape is self-aligning with cup-shaped probes
- Durable stainless steel case engraved with registration number withstands harsh environments
- Easily affixed with self-stick adhesive backing, latched by its flange, or locked with a ring pressed onto its rim

- Presence detector acknowledges when reader first applies voltage

### F5 MICROCAN

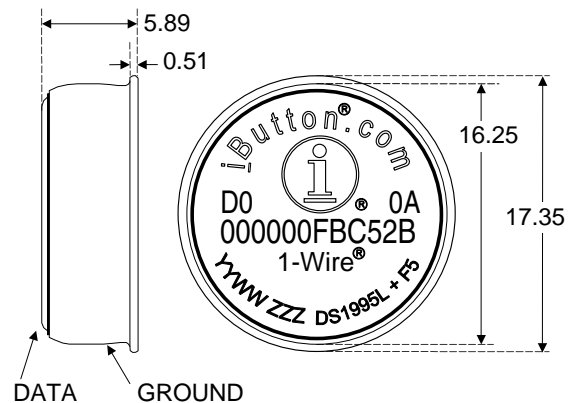

All dimensions are shown in millimeters.

### ORDERING INFORMATION

PART	TEMP RANGE	PIN-PACKAGE
DS1995L-F5+	-40°C to +70°C	F5 MicroCan

+Denotes a lead(Pb)-free/RoHS-compliant package.

### EXAMPLES OF ACCESSORIES

DS9096P	Self-Stick Adhesive Pad
DS9101	Multi-Purpose Clip
DS9093RA	Mounting Lock Ring
DS9093F	Snap-In Fob
DS9092	iButton Probe

### iButton DESCRIPTION

The DS1995 Memory iButton operates nearly identically to the DS1996. The main differences are: 16 Kbits of memory organized as 64 pages of 32 bytes and a family code of 0A hexadecimal. For further details, refer to the DS1996 data sheet.

**REVISION HISTORY**

<b>REVISION DATE</b>	<b>DESCRIPTION</b>	<b>PAGES CHANGED</b>
070808	Updated the <i>Ordering Information</i> table to only show the lead-free version (DS1995-F5+).	1
	Updated the F5 MicroCan marking to match PCN H020201.	1
8/09	Removed the UL#913 bullet from the <i>Common iButton Features</i> section.	1