

DATA SHEET
SE2579U:2.4 GHz High Efficiency Wireless LAN/BT Front End

Applications

- IEEE802.11b DSSS WLAN
- IEEE802.11g,n OFDM WLAN
- Embedded applications with Bluetooth (Mobile)

Features

- Dual Mode IEEE802.11b & IEEE802.11g
- Integrated PA, Harmonic Filter, LNA and BT port
- Integrated Positive Slope Power Detector
- 19 dBm @ 4.0 % EVM, 802.11g, 54 Mbps
- Simultaneous WLAN and Bluetooth receive mode
- Direct connection to battery with 3.3 V nominal supply
- Lead free, Halogen free and RoHS compliant
- Compact package, 3 x 3 x 0.5 mm, MSL 1

Ordering Information

Part No.	Package	Remark
SE2579U	20 pin QFN	Samples
SE2579U-R	20 pin QFN	Tape and Reel
SE2579U-EK1	N/A	Evaluation kit

Product Description

The SE2579U is a complete 802.11 b/g/n WLAN RF front-end module with a Bluetooth port. The device provides all the functionality of the power amplifier, power detector, filter, Switch, Low Noise Amplifier, 2170 MHz notch filtering and associated matching. The SE2579U provides a complete 2.4 GHz WLAN RF solution from the output of the transceiver to the antennas, and from the antennas to the input of the transceiver, in an ultra compact form factor.

The SE2579U is designed for ease of use, with all the critical matching and harmonic filtering integrated, also offering a simple 50 Ω interface to the antenna.

The SE2579U includes a low noise amplifier to increase the receive sensitivity of embedded solutions to improve range or to overcome the insertion loss of cellular filters often included for mobile applications. It offers simultaneous WLAN and Bluetooth receive mode.

The SE2579U also includes a transmitter power detector with 20 dB of dynamic range and a digital enable control for transmitter power ramp on/off control. The power ramp rise/fall time is 0.5 μs typical.

Functional Block Diagram

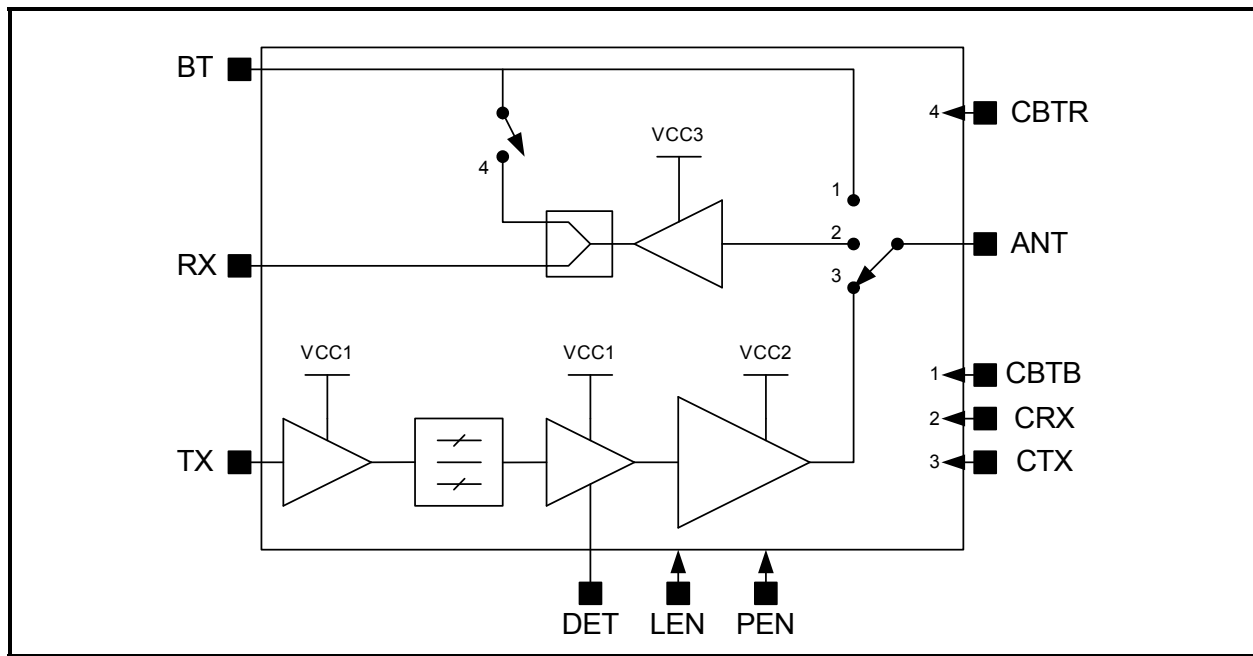

Figure 1: Functional Block Diagram

DATA SHEET
SE2579U:2.4 GHz High Efficiency Wireless LAN/BT Front End

Pin Out Diagram

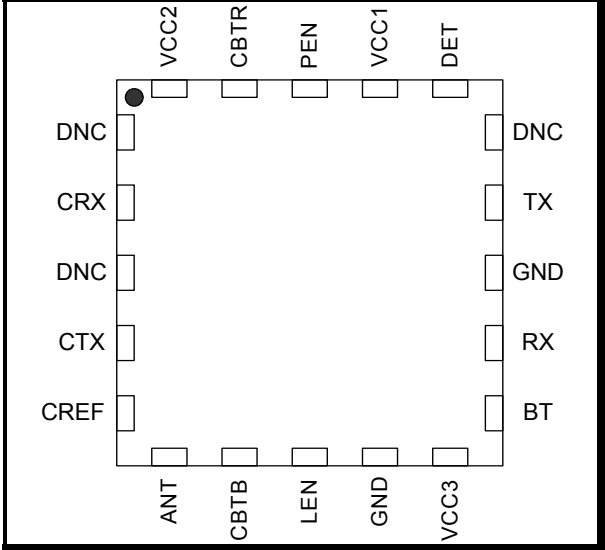

Figure 2: SE2579U Pin out (Top View through Package)



SKYWORKS®

DATA SHEET
SE2579U:2.4 GHz High Efficiency Wireless LAN/BT Front End

DATA SHEET
SE2579U:2.4 GHz High Efficiency Wireless LAN/BT Front End

Pin Out Description

Pin No.	Name	Description
1	DNC	Do Not Connect
2	CRX	WLAN Receive antenna switch control
3	DNC	Do Not Connect
4	CTX	WLAN Transmit antenna switch control
5	CREF	Control pin reference 'high' level input
6	ANT	Antenna Port (must be AC-coupled)
7	CBTB	Bluetooth antenna switch control
8	LEN	LNA Enable
9	GND	Ground
10	VCC3	LNA Power Supply
11	BT	Bluetooth Port (must be AC coupled)
12	RX	WLAN Receive Port (must be AC-coupled)
13	GND	Ground
14	TX	WLAN Transmit Port (must be AC-coupled)
15	DNC	Do Not Connect
16	DET	Transmit Power Detector Output
17	VCC1	Power Amplifier Power Supply
18	PEN	Power Amplifier Enable
19	CBTR	Bluetooth back-end switch control
20	VCC2	Power Amplifier Power Supply
Die paddle	GND	Ground

DATA SHEET
SE2579U:2.4 GHz High Efficiency Wireless LAN/BT Front End
Absolute Maximum Ratings

These are stress ratings only. Exposure to stresses beyond these maximum ratings may cause permanent damage to, or affect the reliability of the device. Avoid operating the device outside the recommended operating conditions defined below. This device is ESD sensitive. Handling and assembly of this device should be at ESD protected workstations.

Symbol	Definition	Min.	Max.	Unit
VCC	Supply Voltage on VCC	-0.3	5.5	V
V _{IN}	DC input on control pins	-0.3	3.6	V
P _{TXIN}	TX Input Power, ANT terminated in 50Ω match	-	5	dBm
T _A	Operating Temperature Range	-30	85	°C
T _{STG}	Storage Temperature Range	-40	150	°C
ESD _{HBM}	JEDEC JESD22-A114 All pins except ANT, CBTB, LEN, Vcc3,BT, RX pins ANT, BT pins with recommended application circuit ANT, CBTB, LEN, Vcc3, BT, RX pins		1000 1000 400	V

Recommended Operating Conditions

Symbol	Parameter	Min.	Typ.	Max.	Unit
T _A	Ambient temperature	-30	25	85	°C
V _{CC}	Supply voltage, relative to GND = 0 V	2.7	3.3	4.8	V

DC Electrical Characteristics

Conditions: V_{CC} = P_{EN} = 3.3 V, T_A = 25 °C, as measured on Skyworks Solutions' SE2579U-EK1 evaluation board (de-embedded to device), all unused ports terminated with 50 ohms, unless otherwise noted

Symbol	Parameter	Conditions	Min.	Typ.	Max.	Unit
I _{CC-G}	Total Supply Current	POUT = 18 dBm, 54 Mbps OFDM signal, 64QAM	-	185	210	mA
I _{CC-B}	Total Supply Current	P _{OUT} = 20 dBm, 11 Mbps CCK signal, BT = 0.45	-	215	248	mA
I _{CC}	Quiescent Current	No RF	-	133	148	mA
I _{CC-OFF}	Total Supply Current	P _{EN} = 0 V, No RF Applied, CBTR = CBTB = CTX = CRX = 0 V	-	5	10	μA
I _{CC-LNA}	Total Supply Current	LEN = V _{CC}	-	8	12	mA
I _{CC-LNA-BYP}	Total Supply Current in bypass mode	LEN = 0 V	-	50	100	μA

DATA SHEET
SE2579U:2.4 GHz High Efficiency Wireless LAN/BT Front End

Control Logic Characteristics

Conditions: $V_{CC} = PEN = 3.3\text{ V}$, $T_A = 25\text{ }^\circ\text{C}$, as measured on Skyworks Solutions' SE2579U-EK1 evaluation board (de-embedded to device), all unused ports terminated with 50 ohms, unless otherwise noted.

Symbol	Parameter	Conditions	Min.	Typ.	Max.	Unit
V_{IH}	Logic High Voltage	-	2.7.	-	3.3	V
V_{IL}	Logic Low Voltage	-	0	-	0.4	V
I_{IH}	Input Current Logic High Voltage	-	-		10	μA
I_{IL}	Input Current Logic Low Voltage	-	-		1	μA

Control Logic Table

Mode#	Mode Description	CTX	CRX	CBTB	CREF	PEN	LEN	CBTR
0	All Off	0	0	0	X	0	0	0
1	BT	0	0	1	1	0	0	0
2	WLAN Rx, high gain	0	1	0	1	0	1	0
3	WLAN Rx, low gain	0	1	0	1	0	0	0
4	WLAN TX	1	0	0	1	0	0	0
5	WLAN TX + PA enabled	1	0	0	1	1	0	0
6	(BT+WLAN) Rx, high gain	0	1	0	1	0	1	1
7	(BT+WLAN) Rx, low gain	0	1	0	1	0	0	1
8	ANT to (BT+WLAN) connect	0	0	1	1	0	0	1

AC Electrical Characteristics

802.11g Transmit Characteristics

Conditions: $V_{CC} = PEN = 3.3\text{ V}$, $T_A = 25\text{ }^\circ\text{C}$, as measured on Skyworks Solutions' SE2579U-EK1 evaluation board (de-embedded to device), all unused ports terminated with 50 ohms, unless otherwise noted.

Symbol	Parameter	Condition	Min.	Typ.	Max.	Unit
F_{IN}	Frequency Range	-	2400	-	2500	MHz
EVM	EVM	$V_{CC} = 3.3\text{ V}$, $P_{OUT} = 19\text{ dBm}$, 54 Mbps OFDM signal, 64 QAM	-	-	4	%
		$V_{CC} = 3.0\text{ V}$, $P_{OUT} = 18\text{ dBm}$, 54Mbps, OFDM signal, 64 QAM				
		$V_{CC} = 2.7\text{ V}$, $P_{OUT} = 17\text{ dBm}$, 54Mbps, OFDM signal, 64 QAM				



DATA SHEET
SE2579U:2.4 GHz High Efficiency Wireless LAN/BT Front End

Symbol	Parameter	Condition	Min.	Typ.	Max.	Unit
ACPRb	Adjacent Channel Power Ratio 11b	P _{out} = 20dBm, 11Mbps CCK, BT = 0.45 ±11 MHz offset ±22 MHz offset	-	-37 -58	-32 -55	dBc
ACPRg	Adjacent Channel Power Ratio 11g	P _{out} = 18 dBm, 54 Mbps OFDM, 64QAM ±11 MHz offset ±20 MHz offset ±30 MHz offset			-20 -28 -40	dBc
P _{max-OOB}	Out-of-band limited output power	11g - 54 Mbps 11b – 11 Mbps PSD _{OOB} = -43 dBm/MHz, RB = 1 MHz 2310-2390 MHz 2483.5-2500 MHz	16 20	17 20	-	dBm
S ₂₁	Small Signal Gain	-	25	27	30	dB
ΔS ₂₁	Small Signal Gain Variation Over Band	-	-	-	1.5	dBpp
2f	Harmonics	P _{OUT} = 20 dBm, 1 Mbps, 802.11b P _{OUT} = 18 dBm, 54Mbps OFDM signal, 64 QAM	-	-35	-25	dBm/MHz
3f				-52	-43	dBm/MHz
t _{dr} , t _{df}	Delay and rise/fall Time	50 % of V _{PEN} edge and 90/10 % of final output power level	-	0.5	1	μs
S ₁₁	Input Return Loss	TX port	-	-15	-10	dB
S _{21WCDMA}	Small Signal Gain in WCDMA band	2110-2170 MHz, relative to min in-band gain			-11	dBr
P _{NWCDMA}	Output noise power in WCDMA band	2110-2170 MHz P _{OUT} = 20 dBm, 1 Mbps, 802.11b P _{OUT} = 18 dBm, 54Mbps OFDM signal, 64 QAM		-130	-127	dBm/Hz
STAB	Stability	CW, P _{in} = -5 dBm 0.1 GHz – 20 GHz Load VSWR = 6:1	All non-harmonically related outputs less than -43 dBm/MHz			
RGGD	Ruggedness	CW, P _{IN} = -5 dBm 0.1 GHz – 20 GHz Load VSWR = 10:1	No permanent damage or performance degradation			

DATA SHEET
SE2579U:2.4 GHz High Efficiency Wireless LAN/BT Front End

Power Detector Characteristics

Conditions: $V_{CC} = PEN = 3.3\text{ V}$, $T_A = 25\text{ °C}$, as measured on Skyworks Solutions' SE2579U-EK1 evaluation board (de-embedded to device), unless otherwise noted.

Symbol	Parameter	Condition	Min.	Typ.	Max.	Unit
F_{OUT}	Frequency Range	-	2400	-	2500	MHz
PDR	Power detect range, CW	Measured at ANT	0	-	22	dBm
PDZ _{LOAD}	Output Impedance	-		2.2		K Ω
PDV _{NoRF}	Output Voltage, $P_{OUT} =$ No RF	Measured in to 1M Ω	0.1	0.125	0.150	V
PDV _{p18.5}	Output Voltage, $P_{OUT} =$ 18.5 dBm CW	Measured in to 1M Ω	0.56	0.66	0.76	V
PDV _{p20}	Output Voltage, $P_{OUT} =$ 20 dBm CW	Measured in to 1M Ω	0.70	0.80	0.90	V
PD _{TVAR}	Detector variation over temperature	-30 to 25 deg C 25 to 85 deg C given detector voltage	-0.6		+0.5	dB
PD _{FVAR}	Detector variation over frequency	2400-2500 MHz given detector voltage	-0.5		0.5	dB
PD _{VSWR}	Detector variation over load VSWR	Forward power ANT VSWR 3:1 all phases given detector voltage	-2		+1	dB
PD _{BW}	Detector bandwidth			1		MHz



DATA SHEET
SE2579U:2.4 GHz High Efficiency Wireless LAN/BT Front End



Figure 3: Power Detector Characteristic

DATA SHEET
SE2579U:2.4 GHz High Efficiency Wireless LAN/BT Front End

Bluetooth Characteristics

Conditions: $V_{CC} = 3.3\text{ V}$, $T_A = 25\text{ }^\circ\text{C}$, as measured on Skyworks Solutions' SE2579U-EK1 evaluation board (de-embedded to device), all unused ports terminated with 50 ohms, unless otherwise noted.

Symbol	Parameter	Condition	Min.	Typ.	Max.	Unit
F _{OUT}	Frequency Range	-	2400	-	2500	MHz
BT _{IL}	Insertion Loss	BT-ANT, CBTB=hi, CBTR=CTX=CRX=lo	-	1.2	1.5	dB
S ₁₁	BT Port Return Loss	CBTB=hi, CBTR=CTX=CRX=lo			-12	dB
ISOL _{SW}	Switch Isolation	ANT-RX, CBTB=hi, CBTR=CTX=CRX=lo	20			dB

2.4 GHz Receive Characteristics

Conditions: $V_{CC} = 3.3\text{ V}$, $LEN = CRX = CBTR = GREF = 3.3\text{V}$, $PEN = CBTB = CTX = 0\text{ V}$, $T_A = 25\text{ }^\circ\text{C}$, as measured on Skyworks Solutions' SE2579U-EK1 evaluation board (de-embedded to device), all unused ports terminated with 50 ohms, unless otherwise noted.

Symbol	Parameter	Condition	Min.	Typ.	Max.	Unit
F _{OUT}	Frequency Range	-	2400	-	2500	MHz
S ₂₁	Receive Gain, LNA enabled.	(BT+WLAN) Rx, high gain	11	13	15	dB
		WLAN Rx, high gain only, LEN = CRX = GREF = 3.3V, PEN = CBTB = CTX = CBTR = 0 V	14	16	18	dB
ΔS ₂₁	Gain Variation	2400 – 2485 MHz, Over any 20MHz band	-	-	0.5	dB
NF	Noise Figure		-	2.0	2.5	dB
IIP3	Third Order Intercept		-3		-	dBm
S ₁₁	Input Return Loss	-			-10	dB
S ₁₂	Reverse Isolation				-20	dB
IP1dB	Input P1dB	CW	-13			dBm
T _{EN}	Enable Time	10% to 90% of RX RF power, from time that LEN is at 50%			500	nsec
S ₂₁ -BYP	Receive Gain, LNA bypassed	LEN = 0 V	-20		-10	dB
S ₁₁ -BYP	Input Return Loss, LNA bypassed	LEN = 0 V			-7	dB
ISOL _{SW}	Switch Isolation	CBTB=CBTR=lo, CRX=hi, ANT-BT + BT-RX	20			dB

DATA SHEET
SE2579U:2.4 GHz High Efficiency Wireless LAN/BT Front End

Package Handling Information

Branding Information

The device branding is shown in Figure 4.

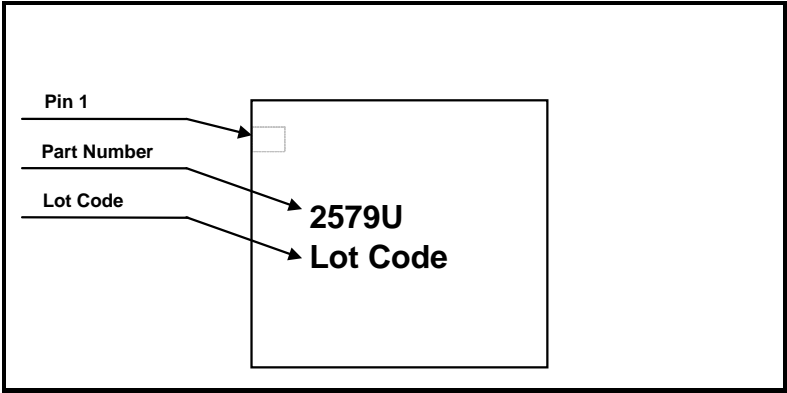

Figure 4: SE2579U Branding and Pin 1 Location

Package Diagram

The package diagram is shown in Figure 5.

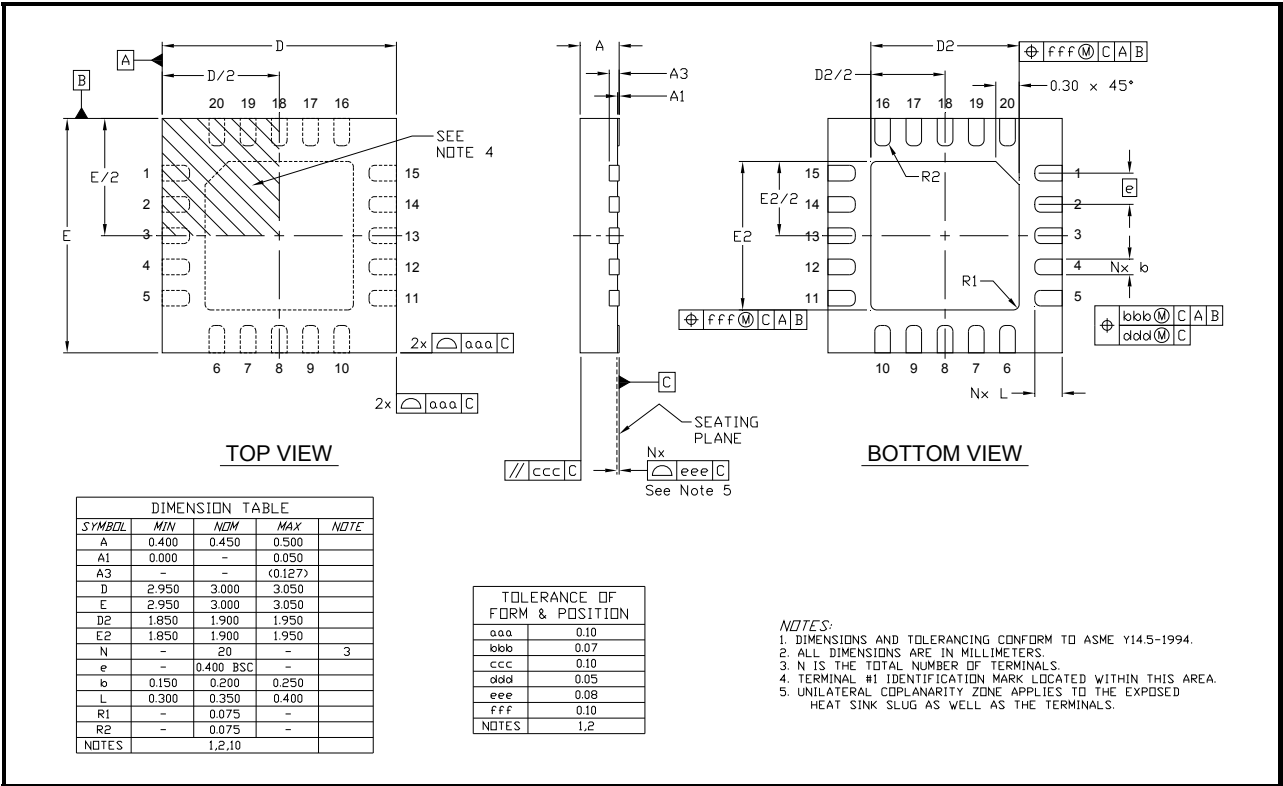
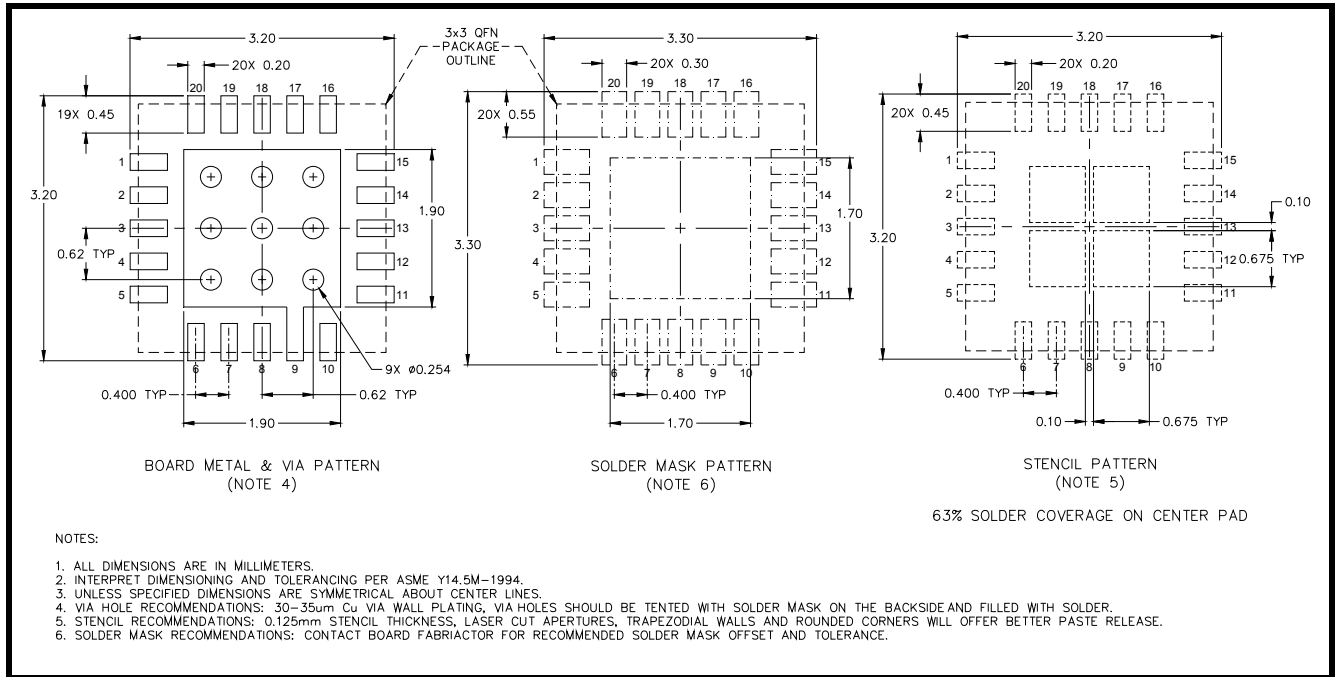

Figure 5: SE2579U Package Diagram

DATA SHEET
SE2579U:2.4 GHz High Efficiency Wireless LAN/BT Front End

Recommended PCB Footprint and Solder pattern



Package Handling Information

Because of its sensitivity to moisture absorption, instructions on the shipping container label must be followed regarding exposure to moisture after the container seal is broken, otherwise, problems related to moisture absorption may occur when the part is subjected to high temperature during solder assembly. The SE2579U is capable of withstanding a Pb free solder reflow. Care must be taken when attaching this product, whether it is done manually or in a production solder reflow environment. If the part is manually attached, precaution should be taken to insure that the device is not subjected to temperatures above its rated peak temperature for an extended period of time. For details on both attachment techniques, precautions, and handling procedures recommended, please refer to:

- “QFN solder reflow and rework information application note”, Document Number QAD-00045
- “Handling, packing, shipping and use of moisture sensitive QFN application note”, Document Number QAD-00044



DATA SHEET
SE2579U:2.4 GHz High Efficiency Wireless LAN/BT Front End

Tape and Reel Information

Parameter	Value
Devices Per Reel	3000
Reel Diameter	13 inches
Tape Width	12 millimeters

Figure 7: SE2579U-R Tape and Reel Information.

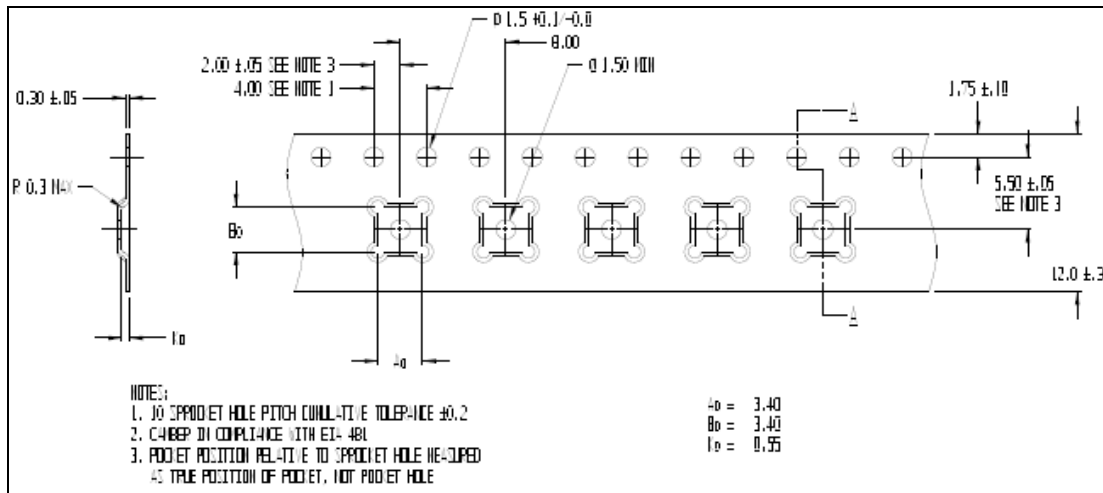

Document Change History

Revision	Date	Notes
1.0	03/02/2009	Initial Release
1.1	3/17/2009	Updated specification
1.2	04/06/2009	Updated maximum control pin voltage to 3.6V
1.3	05/27/2009	Updated specification, and updated back page
1.4	06/25/2009	Updated ESD specification
1.5	08/26/2009	Updated ACPRb specification
1.6	09/20/2009	Updated Power detector specification, and pcb footprint recommendation
1.7	Jan-12-2010	Clarified ESD ratings
1.8	Apr-10-2012	Updated with Skyworks logo and disclaimer statement

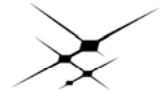

SKYWORKS®

DATA SHEET

SE2579U:2.4 GHz High Efficiency Wireless LAN/BT Front End

Copyright © 2012 Skyworks Solutions, Inc. All Rights Reserved.

Information in this document is provided in connection with Skyworks Solutions, Inc. ("Skyworks") products or services. These materials, including the information contained herein, are provided by Skyworks as a service to its customers and may be used for informational purposes only by the customer. Skyworks assumes no responsibility for errors or omissions in these materials or the information contained herein. Skyworks may change its documentation, products, services, specifications or product descriptions at any time, without notice. Skyworks makes no commitment to update the materials or information and shall have no responsibility whatsoever for conflicts, incompatibilities, or other difficulties arising from any future changes.

No license, whether express, implied, by estoppel or otherwise, is granted to any intellectual property rights by this document. Skyworks assumes no liability for any materials, products or information provided hereunder, including the sale, distribution, reproduction or use of Skyworks products, information or materials, except as may be provided in Skyworks Terms and Conditions of Sale.

THE MATERIALS, PRODUCTS AND INFORMATION ARE PROVIDED "AS IS" WITHOUT WARRANTY OF ANY KIND, WHETHER EXPRESS, IMPLIED, STATUTORY, OR OTHERWISE, INCLUDING FITNESS FOR A PARTICULAR PURPOSE OR USE, MERCHANTABILITY, PERFORMANCE, QUALITY OR NON-INFRINGEMENT OF ANY INTELLECTUAL PROPERTY RIGHT; ALL SUCH WARRANTIES ARE HEREBY EXPRESSLY DISCLAIMED. SKYWORKS DOES NOT WARRANT THE ACCURACY OR COMPLETENESS OF THE INFORMATION, TEXT, GRAPHICS OR OTHER ITEMS CONTAINED WITHIN THESE MATERIALS. SKYWORKS SHALL NOT BE LIABLE FOR ANY DAMAGES, INCLUDING BUT NOT LIMITED TO ANY SPECIAL, INDIRECT, INCIDENTAL, STATUTORY, OR CONSEQUENTIAL DAMAGES, INCLUDING WITHOUT LIMITATION, LOST REVENUES OR LOST PROFITS THAT MAY RESULT FROM THE USE OF THE MATERIALS OR INFORMATION, WHETHER OR NOT THE RECIPIENT OF MATERIALS HAS BEEN ADVISED OF THE POSSIBILITY OF SUCH DAMAGE.

Skyworks products are not intended for use in medical, lifesaving or life-sustaining applications, or other equipment in which the failure of the Skyworks products could lead to personal injury, death, physical or environmental damage. Skyworks customers using or selling Skyworks products for use in such applications do so at their own risk and agree to fully indemnify Skyworks for any damages resulting from such improper use or sale.

Customers are responsible for their products and applications using Skyworks products, which may deviate from published specifications as a result of design defects, errors, or operation of products outside of published parameters or design specifications. Customers should include design and operating safeguards to minimize these and other risks. Skyworks assumes no liability for applications assistance, customer product design, or damage to any equipment resulting from the use of Skyworks products outside of stated published specifications or parameters.

Skyworks, the Skyworks symbol, and "Breakthrough Simplicity" are trademarks or registered trademarks of Skyworks Solutions, Inc., in the United States and other countries. Third-party brands and names are for identification purposes only, and are the property of their respective owners. Additional information, including relevant terms and conditions, posted at www.skyworksinc.com, are incorporated by reference.