



MICRF113

300MHz to 450MHz +10dBm
ASK Transmitter in SOT23

General Description

The MICRF113 is a high-performance, easy-to-use, single-chip ASK Transmitter IC for remote wireless applications in the 300MHz to 450MHz frequency band. This transmitter IC is a true “data-in, antenna-out” monolithic device. MICRF113 has three strong attributes: power delivery, operating voltage and operating temperature. In terms of power, the MICRF113 is capable of delivering +10dBm into a 50Ω load. This power level enables a small form factor transmitter (lossy antenna) such as a key fob transmitter to operate near the maximum limit of transmission regulations. In terms of operating voltage, the MICRF113 operates from 1.8V to 3.6V. Many transmitter ICs in the same frequency band stop operating below 2.0V. The MICRF113 will work with most batteries to the end of their useful limits. In terms of operating temperature, the MICRF113 operates from -40°C to +85°C.

The MICRF113 is easy to use. It requires a reference frequency (RF carrier frequency divided by 32 times) generated from a crystal with a few additional external parts to create a complete versatile transmitter.

The MICRF113 operates with Amplitude Shift Keying/On-Off Keyed (ASK/OOK) UHF receiver types from wide-band super-regenerative radios to narrow-band, high-performance super-heterodyne receivers. The MICRF113's maximum ASK bit rate is 20kbps (minimum pulse width of 50μs at ASK pin).

The MICRF113 transmitter solution is ideal for industrial and consumer applications where simplicity and form factor are important.

Data sheets and support documentation can be found on Micrel's web site at: www.micrel.com.

Features

- Complete UHF ASK transmitter
- Frequency range 300MHz to 450MHz
- Bit rates up to 20kbps
- Output power up to 10dBm
- Low external part count
- Low voltage operation (down to 1.8V)
- Operate with crystals or ceramic resonators
- 6-pin SOT23

Applications

- Fan Controllers
- Remote Power Switches
- Multimedia Remote Control
- Remote Sensor Data Links
- Infrared Transmitter Replacement

Ordering Information

Part Number	Temperature Range	Package
MICRF113YM6	-40°C to +85°C	SOT23-6

QwikRadio is a registered trademark of Micrel, Inc.

Micrel Inc. • 2180 Fortune Drive • San Jose, CA 95131 • USA • tel +1 (408) 944-0800 • fax + 1 (408) 474-1000 • <http://www.micrel.com>

Typical Application

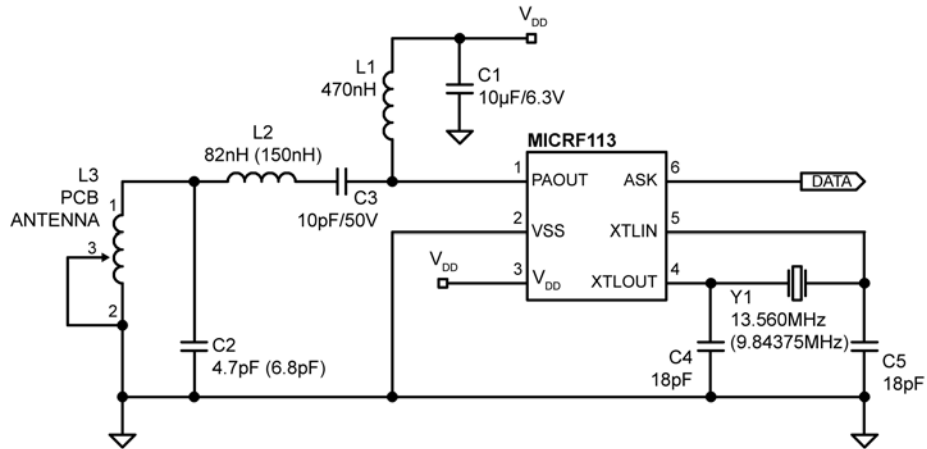
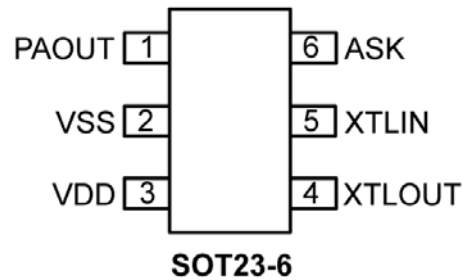

Figure 1. Typical Application Circuit for 433.92MHz and 315MHz (component values for 315MHz in parenthesis)

Pin Configuration



Pin Description

Pin Number MSOP-6	Pin Name	Pin Function
1	PAOUT	PA output
2	VSS	Ground
3	VDD	Positive Power Supply Voltage (Input)
4	XTLOUT	Crystal Out (Output): Reference Oscillator Output Connection.
5	XTLIN	Crystal In (Input): Reference Oscillator Input Connection.
6	ASK	ASK DATA Input

Absolute Maximum Ratings⁽¹⁾

Supply Voltage V_{DD}	+5.0V
Voltage on PA_{OUT}	+7.2V
Voltage on I/O Pins	$V_{SS} - 0.3$ to $V_{DD} + 0.3$
Storage Temperature Range	-65°C to +150°C
Lead Temperature (soldering, 10s).....	+300°C
ESD Rating ⁽³⁾	2kV

Operating Ratings⁽²⁾

Supply Voltage V_{DD}	1.8V to 3.6V
Ambient Operating Temperature (T_A)	-40°C to +85°C
Transmitter Frequency Range	300MHz to 450MHz

Electrical Characteristics⁽⁴⁾

$V_{DD} = 3.0V$, $T_A = 25^\circ C$, $Freq_{REFOSC} = 13.560MHz$. **Bold** values indicate -40°C to 85°C unless otherwise noted. 2kbps bit rate, 50Ω load.

Parameter	Condition	Min.	Typ.	Max.	Units
Power Supply					
Mark Supply Current I_{MARK} , $V_{ASK} = 3.0V$	@ 315MHz, $P_{OUT} = +10dBm$		12.3		mA
	@ 433.92MHz, $P_{OUT} = +10dBm$		12.5		
SPACE Supply Current, I_{SPACE} , $V_{ASK} = 0V$	@ 315MHz		2		mA
	@ 433.92 MHz		2		
RF Output Section and Modulation Limits					
Output Power Level, P_{OUT} ASK "mark"	@315MHz ⁽⁴⁾		10		dBm
	@433.92MHz ⁽⁴⁾		10		
Harmonics Output for 315MHz	@ 630MHz ⁽⁴⁾ 2nd harm.		-39		dBc
	@945MHz ⁽⁴⁾ 3rd harm.		-53		
Harmonics Output for 433.92MHz	@ 867.84MHz ⁽⁴⁾ 2nd harm.		-55		dBc
	@1301.76MHz ⁽⁴⁾ 3rd harm.		-55		
Extinction Ratio for ASK			70		dBc
ASK Modulation					
Encoded Bit Rate				20	kbps
Occupied Bandwidth	@315MHz ⁽⁶⁾		<700		kHz
	@433.92MHz ⁽⁶⁾		<1000		
VCO Section					
315MHz Single-Side Band Phase Noise	@ 100kHz from Carrier		-76		dBc/Hz
	@ 1000kHz from Carrier		-79		
433.92MHz Single-Side Band Phase Noise	@ 100kHz from Carrier		-72		dBc/Hz
	@ 1000kHz from Carrier		-81		

Notes:

1. Exceeding the absolute maximum rating may damage the device.
2. The device is not guaranteed to function outside its operating rating.
3. Devices are ESD sensitive. Handling precautions recommended. Human body model, 1.5k in series with 100pF.
4. Measured using Test Circuit in Figure 2.
5. Dependent on crystal
6. RBW = 100kHz, OBW measured at -20dBc.

Electrical Characteristics⁽⁴⁾ (Continued)

$V_{DD} = 3.0V$, $T_A = 25^\circ C$, $Freq_{REFOSC} = 13.560MHz$. **Bold** values indicate $-40^\circ C$ to $85^\circ C$ unless otherwise noted. 2kbps bit rate, 50Ω load.

Parameter	Condition	Min.	Typ.	Max.	Units
Reference Oscillator Section					
XTLIN, XTLOUT	Pin capacitance		2		pF
External Capacitance	From each side of the crystal to GND		18		pF
Oscillator Startup Time ⁽⁵⁾	Crystal: HC49S		300		μs
Digital / Control Section					
Output Blanking	VDD transition from LOW to HIGH		500		μs
Digital Input ASK Pin	High (V_{IH})	$0.8 \times V_{DD}$			V
	Low (V_{IL})			$0.2 \times V_{DD}$	
Digital Input Leakage Current ASK Pin	High (V_{IH})		0.05		μA
	Low (V_{IL})		0.05		
Undervoltage Lock Out (UVLO)			1.6		V

Test Circuit

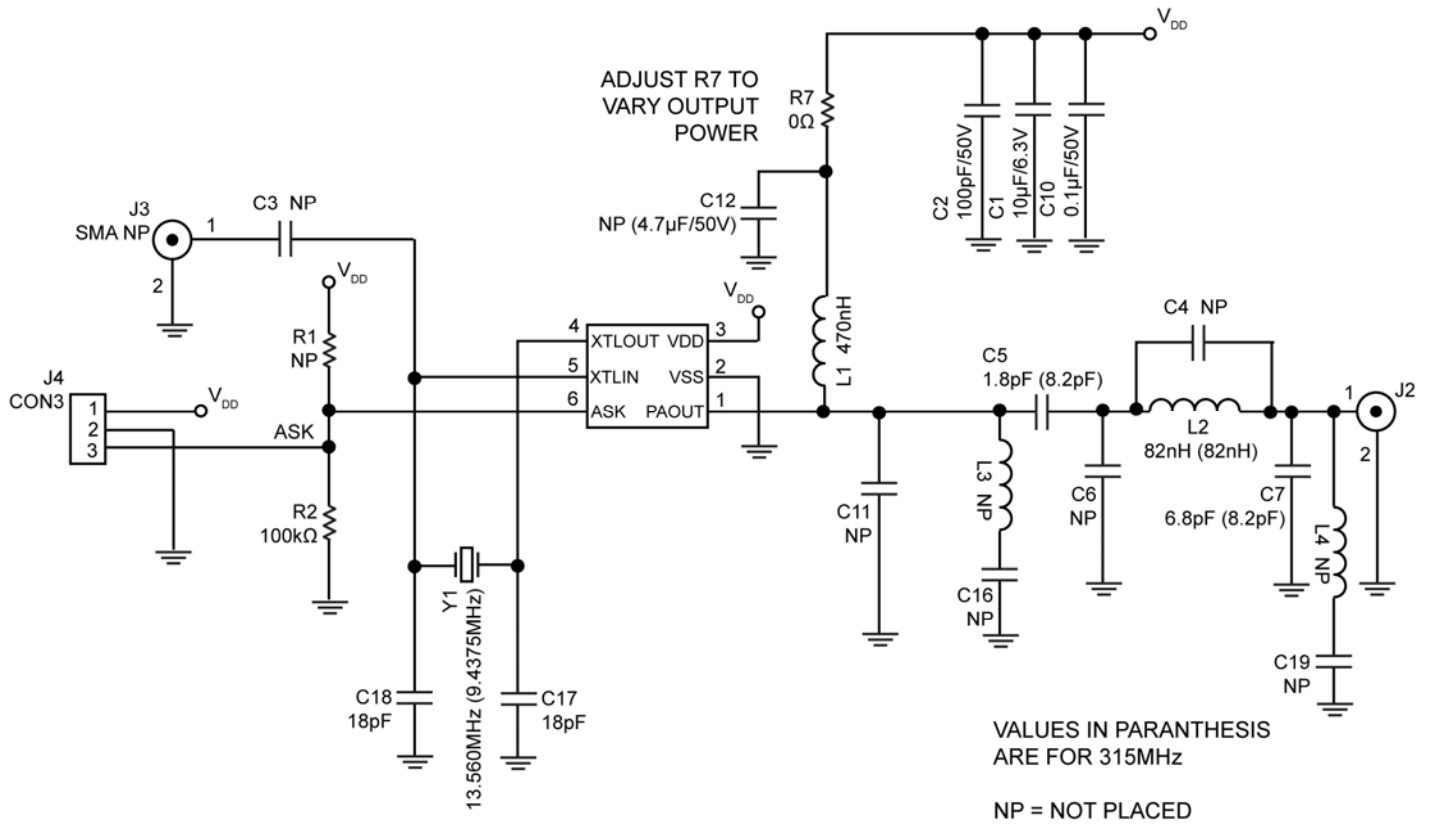
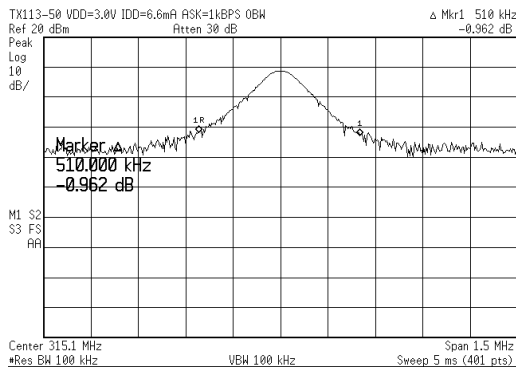

Figure 2. MICRF113 Test Circuit with 50Ω Output

Typical Characteristics – MICRF113 50Ω Test Board

315MHz OBW, ASK = 2kbps



315MHz OBW, ASK = 20kbps

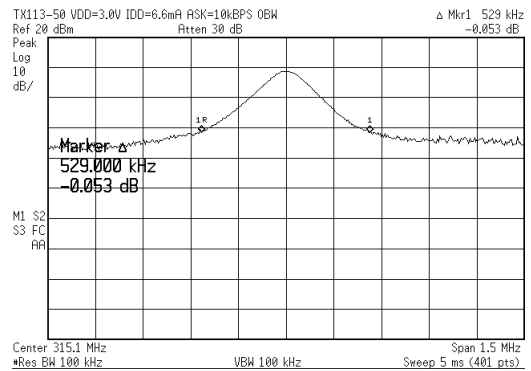

CW Max Power @ 3V, 315MHz⁽¹⁾

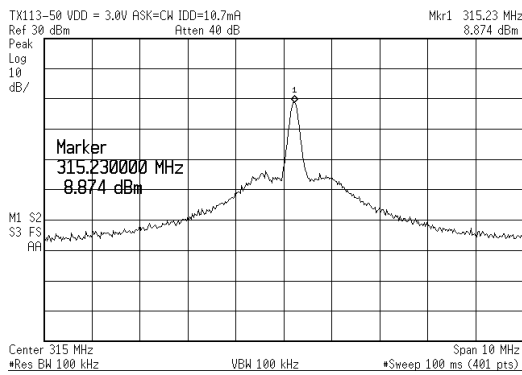

RF Spectrum 2nd Harmonic; Fundamental at 315MHz

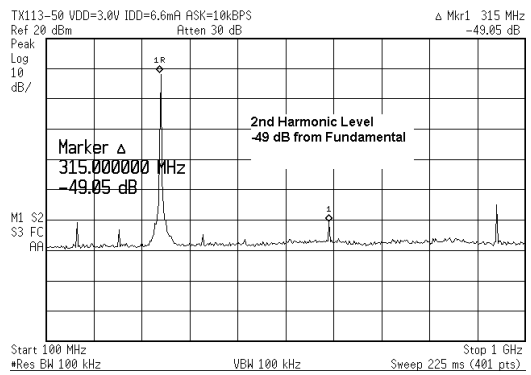

RF Spectrum 3rd Harmonic; Fundamental at 315MHz

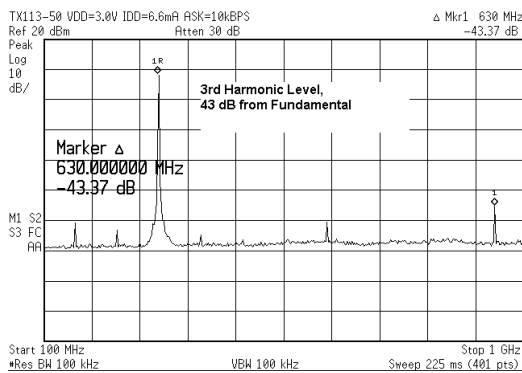

315MHz, Power Level at Space, VDD = 3.0V, ASK = 2kbps, -62dBm

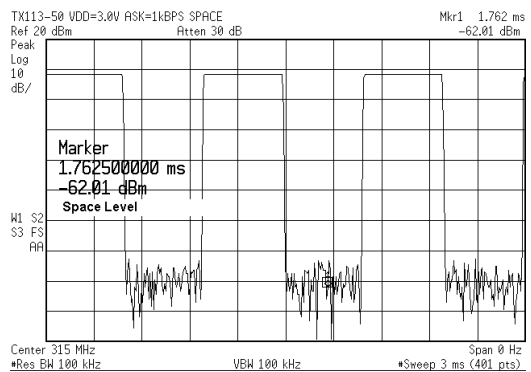

Typical Characteristics – MICRF113 50Ω Test Board (Continued)

315MHz, Zero Span , ASK = 2kbps

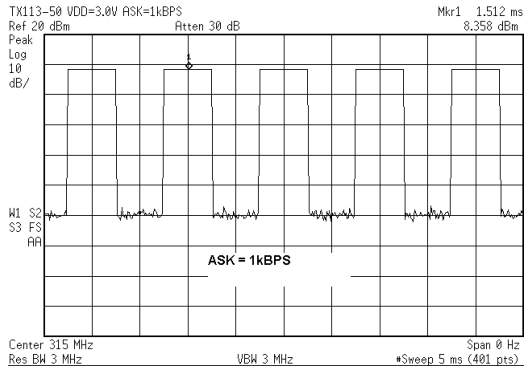

315MHz, Zero Span, ASK = 20kbps

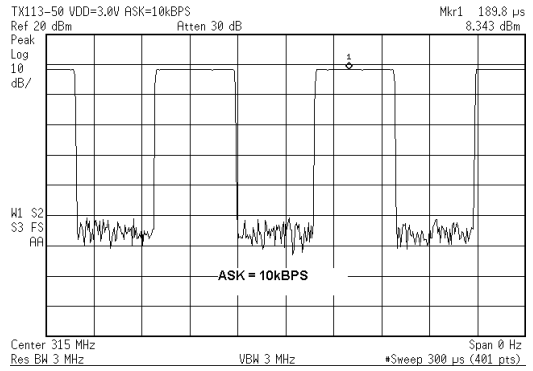

315MHz, Phase Noise, ASK = 2kbps, 100kHz Offset, -75.59dBc/Hz

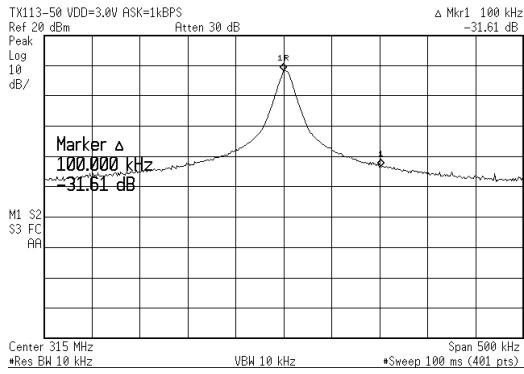

315MHz, Phase Noise, ASK = 2kbps, 1MHz Offset, -78.99dBc/Hz

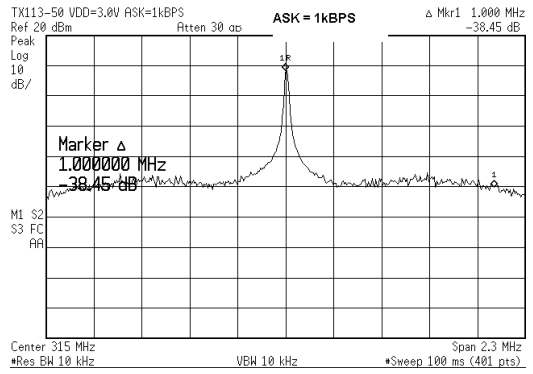

315MHz, Phase Noise, ASK = CW, 100kHz Offset, -70.96dBc/Hz

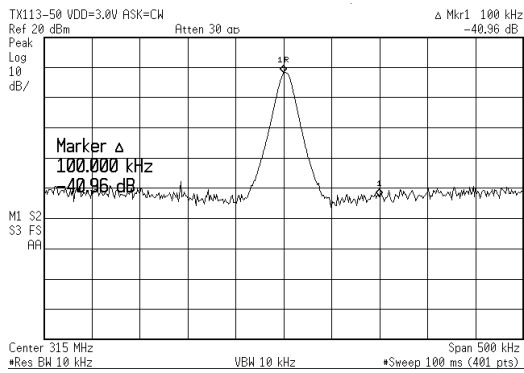

315MHz, Phase Noise, ASK = CW, 1MHz Offset, -76.72dBc/Hz

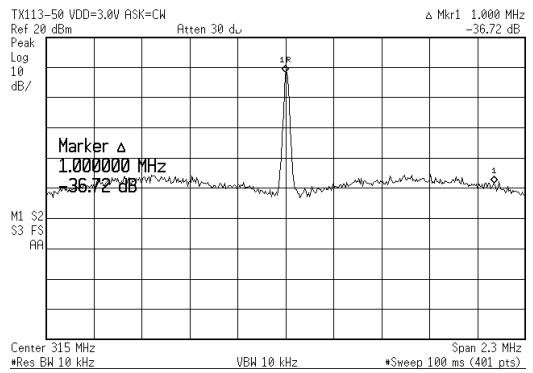

Typical Characteristics – MICRF113 50Ω Test Board (Continued)

433.92MHz OBW, ASK = 2kbps

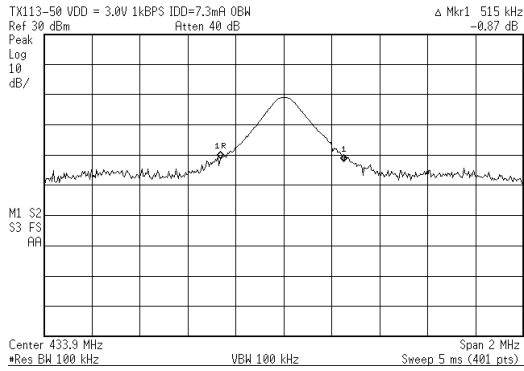

433.92MHz OBW, ASK = 20kbps

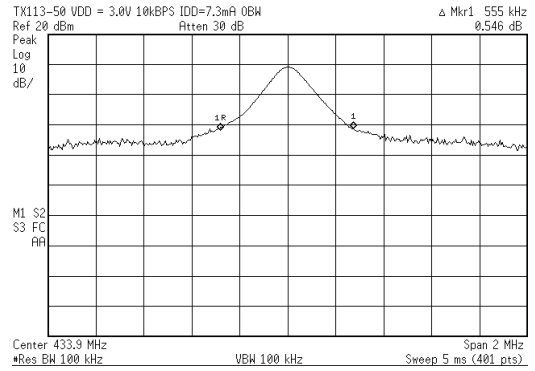

433.92MHz, CW Max Power @ 3V, ASK = 2kbps⁽¹⁾

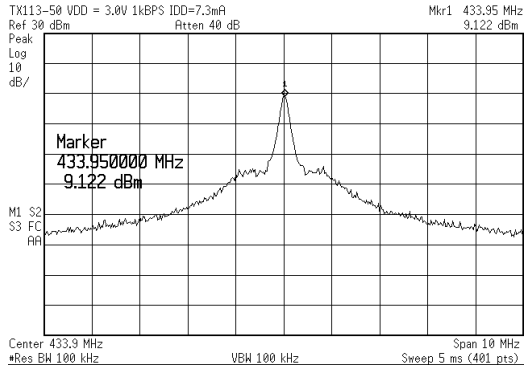

RF Spectrum 2nd Harmonic; Fundamental at 433.92MHz

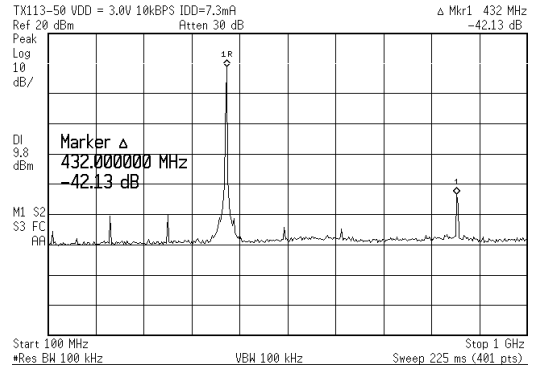

RF Spectrum 3rd Harmonic; Fundamental at 433.92MHz

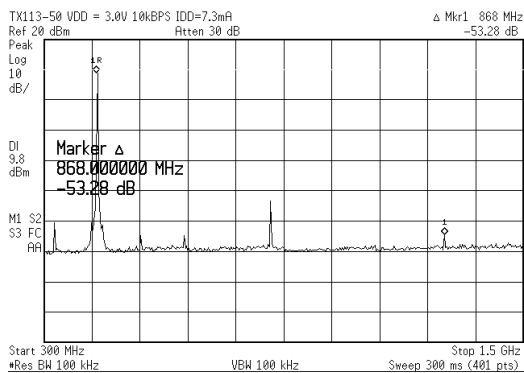

433.92MHz Power Level at Space, VDD = 3.0V, ASK = 2kbps, -52dBm

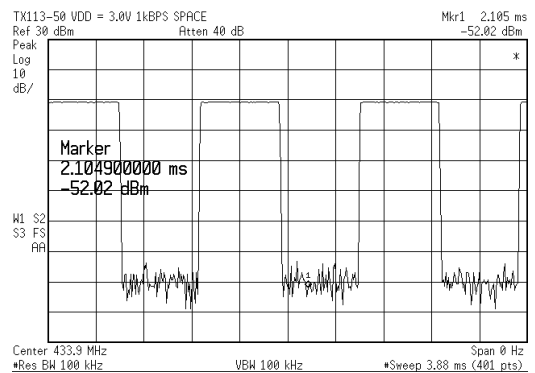

Typical Characteristics – MICRF113 50Ω Test Board (Continued)

433.92MHz Zero Span, 2kbps

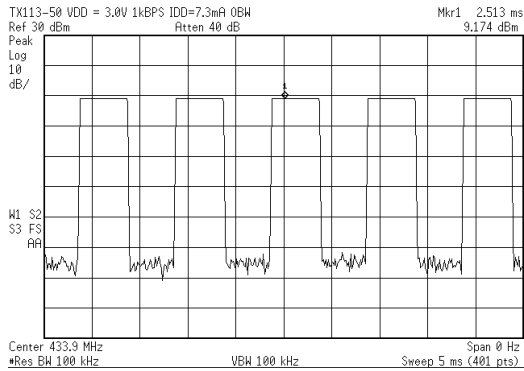

433.92ASK Zero Span at 20kbps

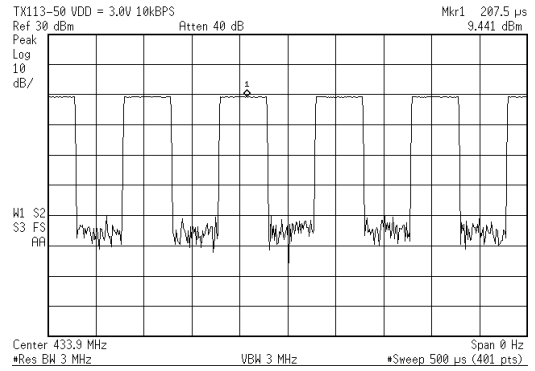

433.92MHz Phase Noise, ASK = CW, 100kHz Offset, -81.73dBc/Hz

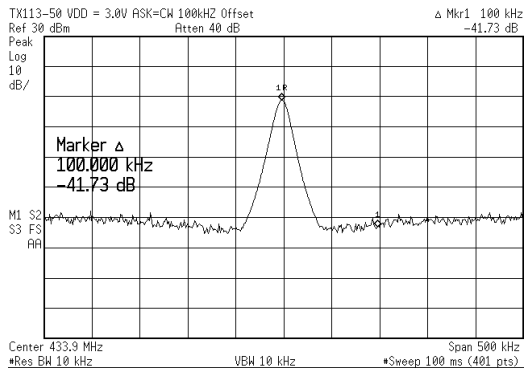

433.92MHz Phase Noise, ASK = CW, 1MHz Offset, -78.49dBc/Hz

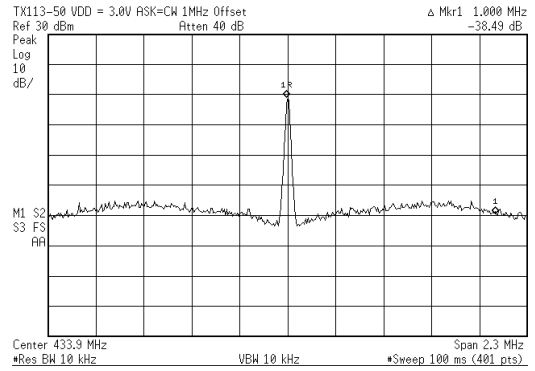

433.92MHz Phase Noise, ASK = 2kbps, 100kHz Offset, -71.64dBc/Hz

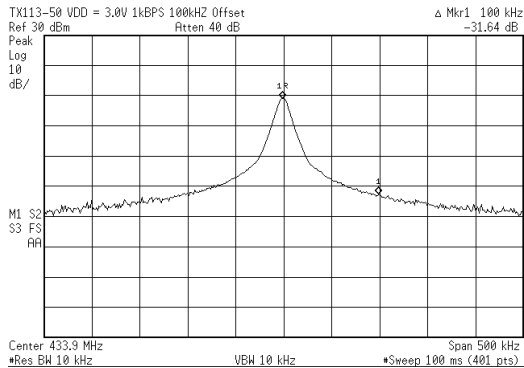

433.92MHz Phase Noise, ASK = 2kbps, 1MHz Offset, -79.4dBc/Hz

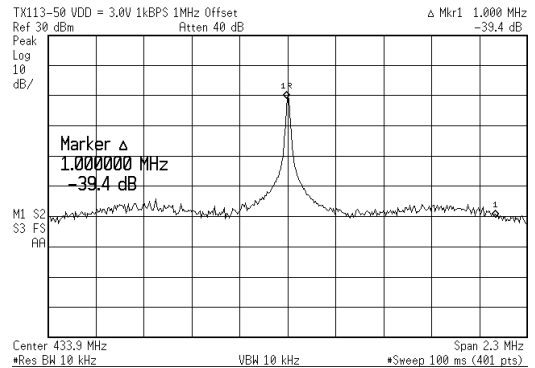

Functional Diagram

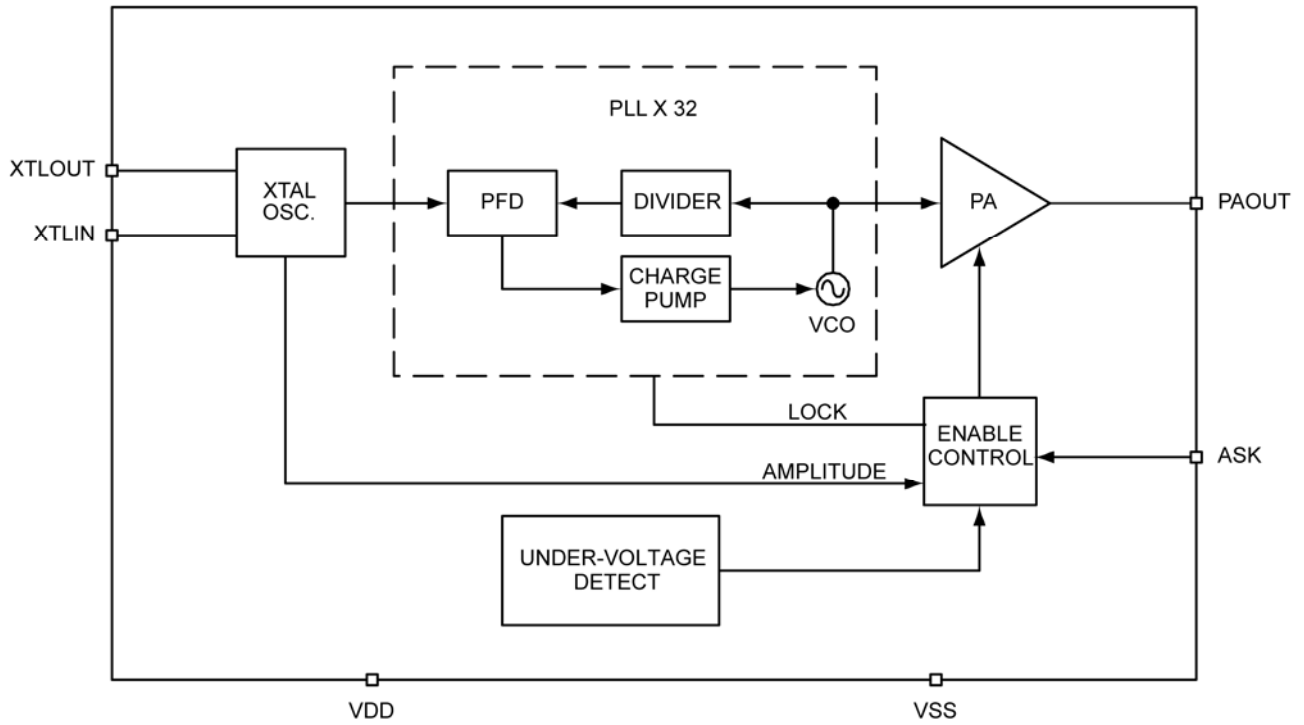

Figure 3. MICRF113 Functional Block Diagram

Functional Description

Figure 3 is a functional block diagram of the MICRF113 transmitter. The MICRF113 is best described as a phase locked transmitter. The MICRF113 system is partitioned into five functional blocks:

- Crystal oscillator
- PLL×32
- Power amplifier
- Enable control
- Undervoltage detection

Crystal Oscillator

The reference oscillator is crystal-based Pierce configuration, designed to accept crystals with frequency from 9.375MHz to 14.0625MHz.

Crystal Oscillator Parameters for ASK Operation

Figure 4 shows a reference oscillator circuit configuration for ASK operation. The reference oscillator is capable of driving crystals with ESR range from 20Ω to 300Ω.

When the ESR of crystal is at 20Ω, the crystal parameter limits are:

- ESR 20Ω
- C_{PAR} 2 to 10pF
- C_{MO} 10 to 40fF

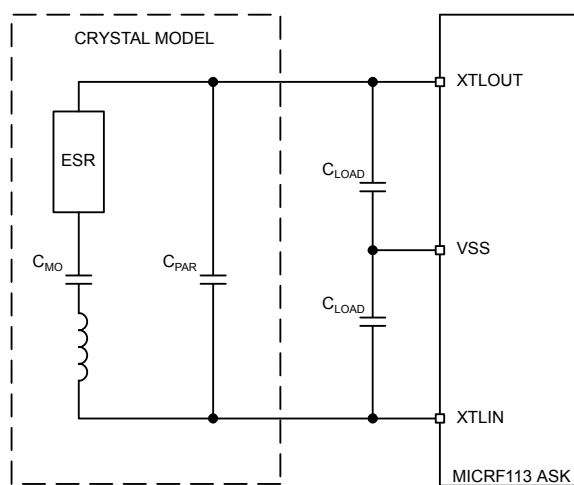

Figure 4. Reference Oscillator ASK Operation

When the ESR of crystal is at 300Ω, the crystal parameter limits are:

- ESR 300Ω
- C_{PAR} 2 to 5pF
- C_{MO} 10 to 40fF
- C_{LOAD} 10 to 30pF

PLL ×32

The function of PLL×32 is to provide a stable carrier frequency for transmission. It is a “divide by 32” phase locked loop oscillator.

Power Amplifier

The power amplifier serves two purposes: 1) to buffer the VCO from external elements and 2) to amplify the phase locked signal. The power amplifier can produce +10dBm at 3V (typical).

Enable Control

Enable control gates the ASK data. It only allows transmission when Lock, Amplitude and Under Voltage Detect conditions are valid.

Undervoltage Detect

“Undervoltage detect” block senses operating voltage. If the operating voltage falls below 1.6V, “undervoltage detect” block will send a signal to “enable control” block to disable the PA.

Application Information

The MICRF113 is well suited to drive a 50Ω load, monopole or a loop antenna. Figure 6 is an example of a loop antenna configuration. Figure 6 also shows both 315MHz and 433.92MHz ASK configurations for a loop antenna. Besides using a different crystal, Table 1 lists modified values needed for the listed frequencies.

Frequency (MHz)	L1 (nH)	C5 (pF)	L4 (nH)	C7 (pF)	Y1 (MHz)
315.0	470	10	150	6.8	9.84375
433.92	820	12	68	4.7	13.5600

Table 1. Modified Values for Listed Frequencies

The reference design shown in Figure 6 has an antenna optimized for using the matching network as described in Table 1.

Power Amplitude Control Using External Resistor

R7 is used to adjust the RF amplitude output levels which may be needed to meet compliance regulation. As an example, the following tables list typical values of conducted RF output levels and corresponding R7 resistor values for the 50Ω test board, as shown in Figure 2. R7 of the TX113-1C Demo board using the loop antenna can be adjusted for the appropriate radiated field allowed by FCC or ETSI compliance. Contact Micrel for suggested R7 values to meet FCC and ETSI compliances.

50Ω Test Board, VDD = 3.0V		
R7 (Ω)	Output Power (dBm)	IDD (mA)
0	10	12.3
75	8.5	11
100	8.0	10.5
500	3.0	7.3
1000	-2.0	5.9

Table 2. Output Power vs. External Resistor @ 315MHz

50Ω Test Board, VDD = 3.0V		
R7 (Ω)	Output Power (dBm)	IDD (mA)
0	9.8	12.5
75	8.9	12
100	8.6	11.8
500	2.0	8.9
1000	-3.0	7.3

Table 3. Output Power vs. External Resistor @ 433.92MHz

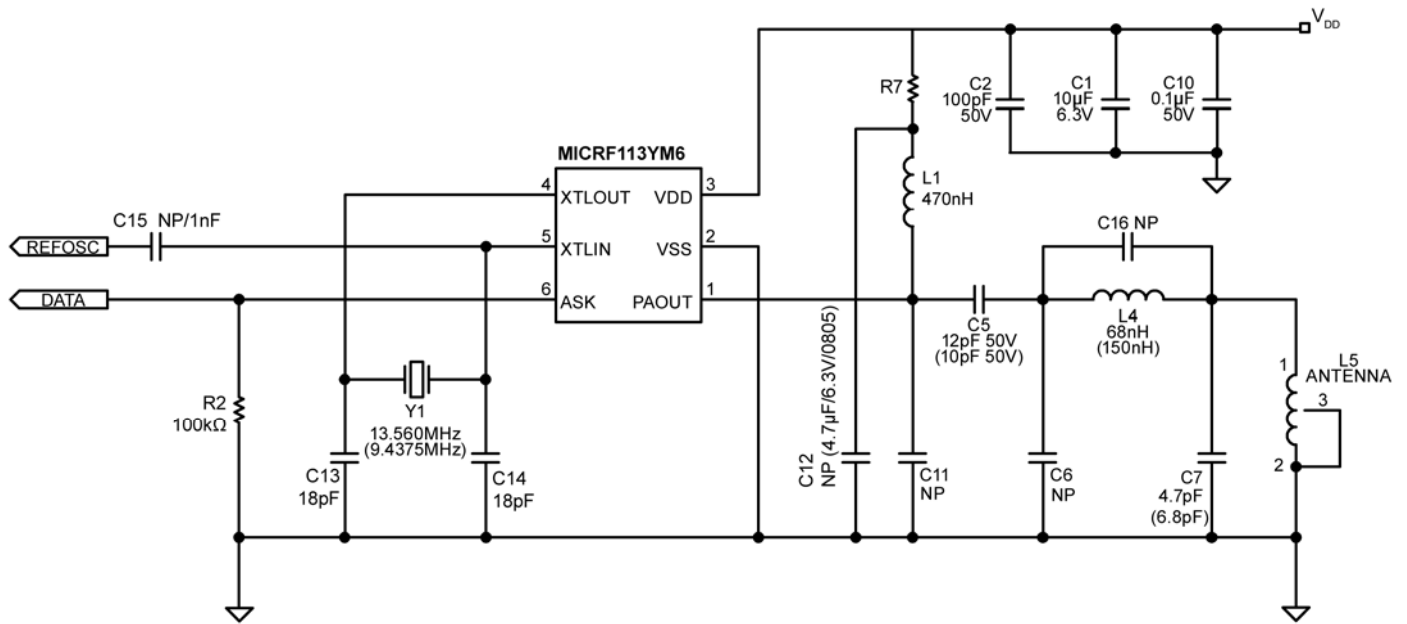

Notes:

1. Components labeled NP are not placed.
2. Values in parenthesis apply only to 315MHz option.
3. Value of R7 is selected to vary the output power.

Figure 6. ASK 433.92MHz and 315MHz

Output Power ON-OFF Control

There are two ways to enable the PA output power. First, by supplying the ASK signal with VDD applied continuously, resulting in a Mark and Space RF output condition. A second method involves applying both VDD and ASK synchronously. The second method allows for longer battery usage since the battery is disconnected during non-activation. Figure 7 shows the RF output time response since VDD and the ASK are applied to the MICRF113. The RF output response, as a function of VDD, is typically less than 1.25mSec. This measurement was done using the circuitry shown in Figure 2.

Note: The ASK signal should never be applied before VDD.

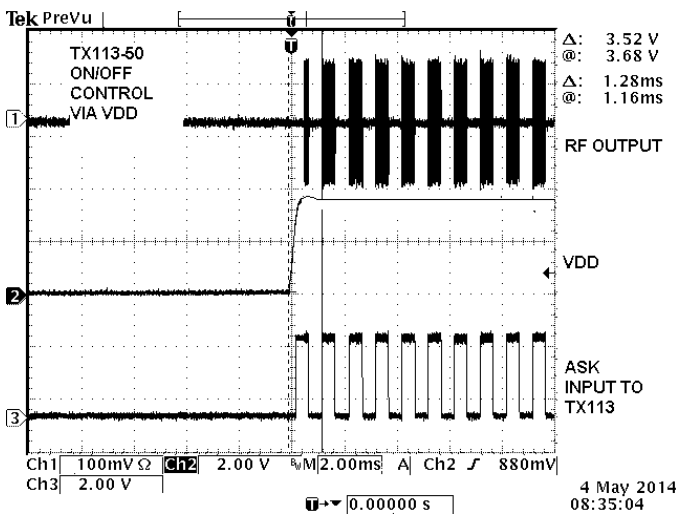

Figure 7. RF Output Response (VDD and ASK)

Output Matching Network

Part of the function of the output network is to attenuate the second and third harmonics. When matching to a transmit frequency, care must be taken both to optimize for maximum output power, and to attenuate unwanted harmonics.

Layout Issues

PCB Layout is a primary concern for achieving optimum performance and consistent manufacturing results. Care must be used with the orientation of components to ensure that they do not couple or decouple the RF signal. PCB trace length should be short to minimize parasitic inductance (1 inch ~ 20nH). For example, depending upon inductance values, a 0.5 inch trace can change the inductance by as much as 10%. To reduce parasitic inductance, the practice of using wide traces and a ground plane under the signal traces is recommended. Vias with low value inductance should be used for components requiring a connection-to-ground.

Antenna Layout

Directivity is affected by antenna trace layout. No ground plane should be under the antenna trace. For consistent performance, components should not be placed inside the loop of the antenna. Gerber formats (see Figure 8, for a suggested layout) can be obtained from the Micrel web site at: <http://www.micrel.com>.

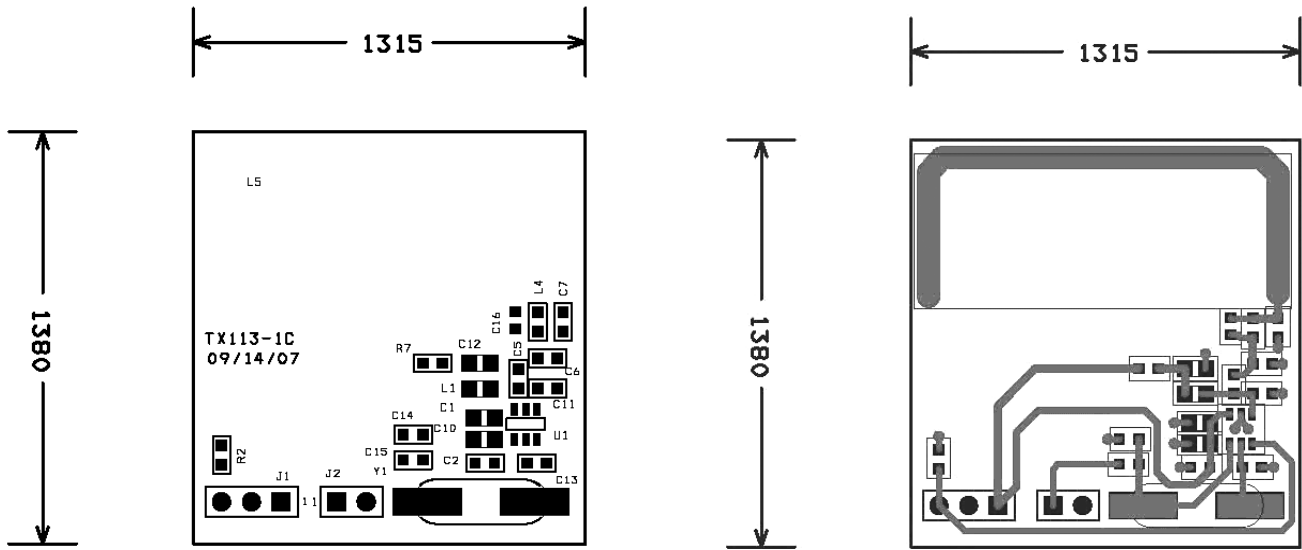

Assembly Drawing

Top Layer

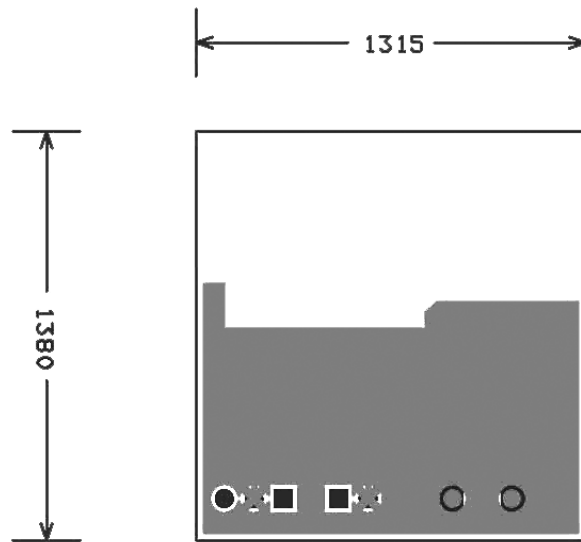

Bottom Layer

Figure 8. PCB Demo Board

Functional Description

Figure 8 shows the TX113-1c Demo Board PCB layout and assembly (Gerber format). Figure 9 is a detailed schematic of the TX113-1c. Note that components labeled as NP (not placed) can be used to obtain different configurations. Table 4 describes each header pin connector used in the demo board.

Pin	Function Name	Functional Description
J1-1	VDD	1.8V to 3.6V input voltage
J1-2	VSS	Ground
J1-3	ASK	Modulating Data Input
J2-1	REF-OSC	External Reference Oscillator Input
J2-2	VSS	Ground

Table 4. Demo Board Pin Names and Descriptions

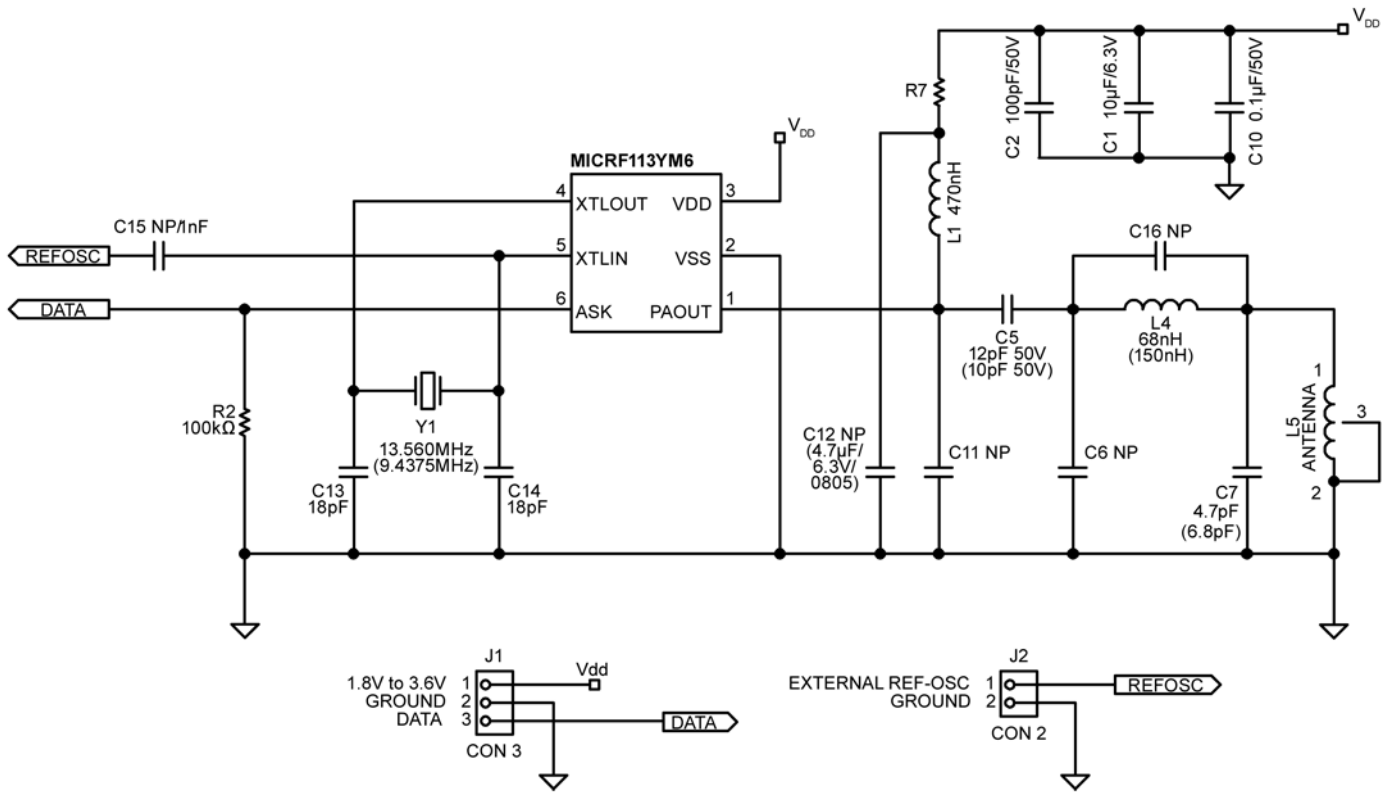

Notes:

1. NP = Not Placed
2. Values in parenthesis apply only to 315MHz option.
3. R7 is selected to vary output power

Figure 9. TX113-1c Demo Board Schematic

Bill of Materials (433.92MHz)

Item	Part Number	Manufacturer	Description	Qty.
C1	GRM21BR60J106K	Murata ⁽¹⁾	10 μ F \pm 10%, 0805 capacitor	1
C2	GRM1885C1H101J	Murata ⁽¹⁾	100pF \pm 5%, 0603 capacitor	1
C5	GRM1885C1H120J	Murata ⁽¹⁾	12pF \pm 5%, 0603 capacitor	1
C6, C11, C16		Murata ⁽¹⁾	(NP)	3
C7	GQM1875C2E4R7C	Murata ⁽¹⁾	4.7pF \pm 0.25pF, 0603 capacitor	1
C10	GRM188R61C104K	Murata ⁽¹⁾	0.1 μ F \pm 10%, 0603 capacitor	1
C13, C14	GRM1885C1H180J	Murata ⁽¹⁾	18pF \pm 5%, 0603 capacitor	2
J1	TSHR-114-S-02-A-GT		3-pin header	1
L1	0805CS-471XJB	Coilcraft ⁽²⁾	470nH \pm 5%, 0805 wire-wound inductor	1
L4	0603CS-068NXJB	Coilcraft ⁽²⁾	68nH \pm 5%, 0603 wire-wound inductor	1
L5	ANTENNA LOOP (Part of PCB)		PCB ANTENNA	1
R2	CRCW0603100KFKEA	Vishay ⁽³⁾	100k Ω \pm 5%, 0603 resistor	1
R7	CRC06030000Z0EA	Vishay ⁽³⁾	0 Ω \pm 5%, 0603 resistor	1
Y1	SA-13.5600-F-10-J-30-30-x	Hosonic Industrial Brazil ⁽⁴⁾	13.560MHZ \pm 30ppm crystal	1
U1	MICRF113YM6	Micrel, Inc. ⁽⁵⁾	300MHz to 450MHz +10dBm ASK Transmitter in SOT23	1

Notes:

1. Murata Tel: www.murata.com.
2. Coilcraft.: www.coilcraft.com.
3. Vishay Tel: www.vishay.com.
4. Hosonic Industrial Brazil: www.hib.com.br
5. **Micrel, Inc.:** www.micrel.com.

Bill of Materials (315MHz)

Item	Part Number	Manufacturer	Description	Qty.
C1	GRM21BR60J106K	Murata ⁽¹⁾	10 μ F \pm 10%, 0805 capacitor	1
C2	GRM1885C1H101J	Murata ⁽¹⁾	100pF \pm 5%, 0603 capacitor	1
C5	GRM1885C1H120J	Murata ⁽¹⁾	10pF \pm 5%, 0603 capacitor	1
C6, C11, C16		Murata ⁽¹⁾	(NP)	3
C7	GQM1875C2E4R7C	Murata ⁽¹⁾	6.8pF \pm 0.25pF, 0603 capacitor	1
C10	GRM188R61C104K	Murata ⁽¹⁾	0.1 μ F \pm 10%, 0603 capacitor	1
C13, C14	GRM1885C1H180J	Murata ⁽¹⁾	18pF \pm 5%, 0603 capacitor	2
J1, J2	TSHR-114-S-02-A-GT		3-pin header	1
L1	0805CS-471XJB	Coilcraft ⁽²⁾	470nH \pm 5%, 0805 wire-wound inductor	1
L4	0603CS-R15XJB	Coilcraft ⁽²⁾	150nH \pm 5%, 0603 wire-wound inductor	1
L5	ANTENNA LOOP (Part of PCB)		PCB ANTENNA	1
R2	CRCW0603100KFKEA	Vishay ⁽³⁾	100k Ω \pm 5%, 0603 resistor	1
R7	CRC06030000Z0EA	Vishay ⁽³⁾	0 Ω \pm 5%, 0603 resistor	1
Y1	SA-9.84375-F-10- J-30-30-x	Hosonic Industrial Brazil ⁽⁴⁾	9.84375MHZ \pm 30ppm crystal	1
U1	MICRF113YM6	Micrel, Inc. ⁽⁵⁾	300MHz to 450MHz +10dBm ASK Transmitter in SOT23	1

Notes:

1. Murata Tel: www.murata.com
2. Coilcraft.: www.coilcraft.com.
3. Vishay Tel: www.vishay.com.
4. Hosonic Industrial Brazil: www.hib.com.br
5. **Micrel, Inc.:** www.micrel.com.

PCB Layout Recommendations (50Ω Test Board)

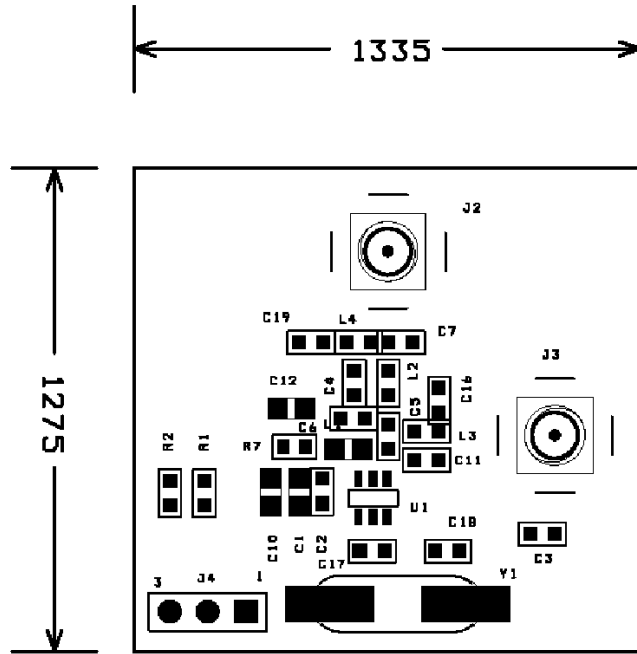

Assembly Drawing

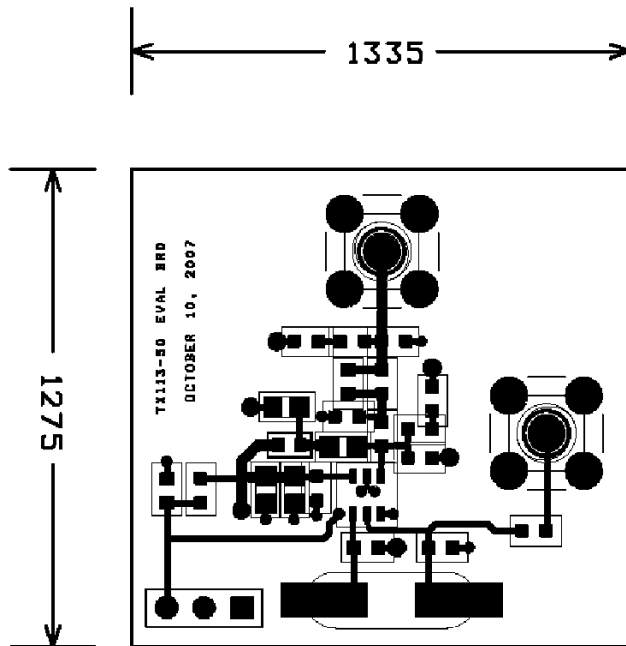

Top Layer

PCB Layout Recommendations (50Ω Test Board)

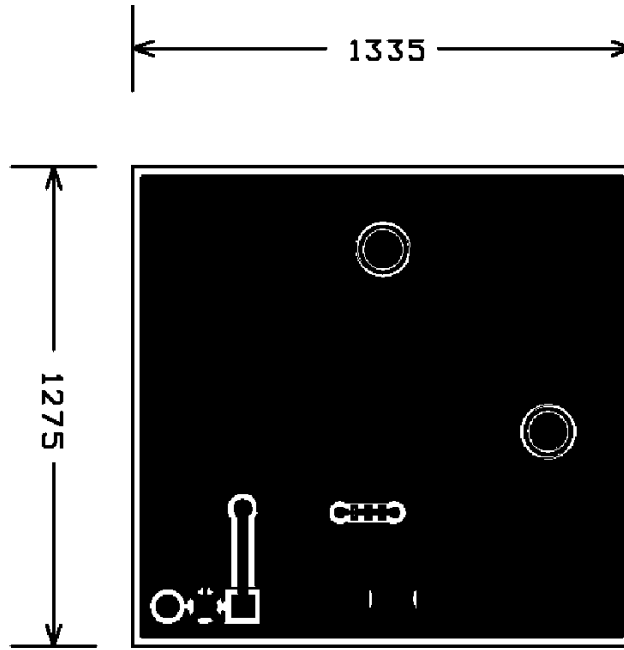

Bottom Layer

Package Information

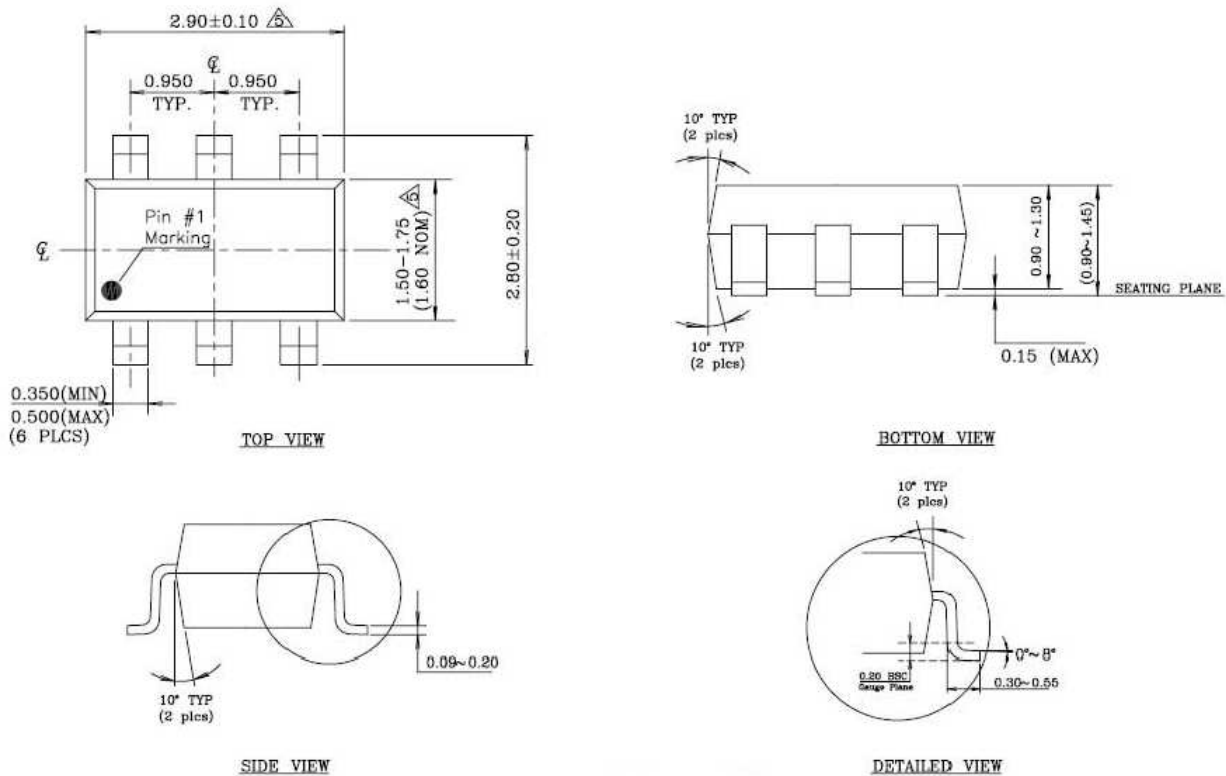

Notes:

1. Dimensions and tolerances are in accordance with ANSI Y14.5M, 1982.
2. Package surface to be mirror finish.
3. Die is facing up for mold. Die is facing down for trim/form, that is, reverse trim/form.
4. The foot-length measuring is based on the gauge plane method.

Δ Dimensions are exclusive of mold flash and gate burr.

6-Pin SOT (YM6)

MICREL, INC. 2180 FORTUNE DRIVE SAN JOSE, CA 95131 USA
 TEL +1 (408) 944-0800 FAX +1 (408) 474-1000 WEB <http://www.micrel.com>

Micrel makes no representations or warranties with respect to the accuracy or completeness of the information furnished in this data sheet. This information is not intended as a warranty and Micrel does not assume responsibility for its use. Micrel reserves the right to change circuitry, specifications and descriptions at any time without notice. No license, whether express, implied, arising by estoppel or otherwise, to any intellectual property rights is granted by this document. Except as provided in Micrel's terms and conditions of sale for such products, Micrel assumes no liability whatsoever, and Micrel disclaims any express or implied warranty relating to the sale and/or use of Micrel products including liability or warranties relating to fitness for a particular purpose, merchantability, or infringement of any patent, copyright or other intellectual property right

Micrel Products are not designed or authorized for use as components in life support appliances, devices or systems where malfunction of a product can reasonably be expected to result in personal injury. Life support devices or systems are devices or systems that (a) are intended for surgical implant into the body or (b) support or sustain life, and whose failure to perform can be reasonably expected to result in a significant injury to the user. A Purchaser's use or sale of Micrel Products for use in life support appliances, devices or systems is a Purchaser's own risk and Purchaser agrees to fully indemnify Micrel for any damages resulting from such use or sale.

© 2008 Micrel, Incorporated.