

FEATURES

- 3.3V and 5V power supply options
- 50ps output-to-output skew
- Synchronous enable/disable
- Master Reset for synchronization
- Internal 75KΩ input pull-down resistors
- Available in 20-pin SOIC package

**Precision Edge®****DESCRIPTION**

The SY10/100EL38/L are low skew ÷2, ÷4/6 clock generation chips designed explicitly for low skew clock generation applications. The internal dividers are synchronous to each other, therefore, the common output edges are all precisely aligned. The devices can be driven by either a differential or single-ended ECL or, if positive power supplies are used, PECL input signal. In addition, by using the VBB output, a sinusoidal source can be AC-coupled into the device. If a single-ended input is to be used, the VBB output should be connected to the CLK input and bypassed to ground via a 0.01μF capacitor. The VBB output is designed to act as the switching reference for the input of the EL38/L under single-ended input conditions. As a result, this pin can only source/sink up to 0.5mA of current.

The common enable (\overline{EN}) is synchronous so that the internal dividers will only be enabled/disabled when the internal clock is already in the LOW state. This avoids any chance of generating a runt clock pulse on the internal clock when the device is enabled/disabled as can happen with an asynchronous control. An internal runt pulse could lead to losing synchronization between the internal divider stages. The internal enable flip-flop is clocked on the falling edge of the input clock, therefore, all associated specification limits are referenced to the negative edge of the clock input.

The Phase_Out output will go HIGH for one clock cycle whenever the ÷2 and the ÷4/6 outputs are both transitioning from a LOW to a HIGH. This output allows for clock synchronization within the system.

Upon start-up, the internal flip-flops will attain a random state; the master reset (MR) input allows for the synchronization of the internal dividers, as well as for multiple EL38/Ls in a system.

PACKAGE/ORDERING INFORMATION

Ordering Information⁽¹⁾

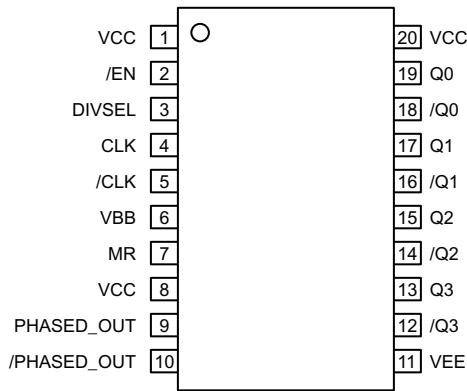

20-Pin SOIC (Z20-1)

Part Number	Package Type	Operating Range	Package Marking	Lead Finish
SY10EL38LZC	Z20-1	Commercial	SY10EL38LZC	Sn-Pb
SY10EL38LZCTR ⁽²⁾	Z20-1	Commercial	SY10EL38LZC	Sn-Pb
SY100EL38LZC	Z20-1	Commercial	SY100EL38LZC	Sn-Pb
SY100EL38LZCTR ⁽²⁾	Z20-1	Commercial	SY100EL38LZC	Sn-Pb
SY10EL38LZI	Z20-1	Industrial	SY10EL38LZI	Sn-Pb
SY10EL38LZITR ⁽²⁾	Z20-1	Industrial	SY10EL38LZI	Sn-Pb
SY100EL38LZI	Z20-1	Industrial	SY100EL38LZI	Sn-Pb
SY100EL38LZITR ⁽²⁾	Z20-1	Industrial	SY100EL38LZI	Sn-Pb
SY10EL38LZG ⁽³⁾	Z20-1	Industrial	SY10EL38LZG with Pb-Free bar-line indicator	Pb-Free NiPdAu
SY10EL38LZGTR ^(2, 3)	Z20-1	Industrial	SY10EL38LZG with Pb-Free bar-line indicator	Pb-Free NiPdAu
SY100EL38LZG ⁽³⁾	Z20-1	Industrial	SY100EL38LZG with Pb-Free bar-line indicator	Pb-Free NiPdAu
SY100EL38LZGTR ^(2, 3)	Z20-1	Industrial	SY100EL38LZG with Pb-Free bar-line indicator	Pb-Free NiPdAu

Notes:

1. Contact factory for die availability. Dice are guaranteed at T_A = 25°C, DC Electricals only.
2. Tape and Reel.
3. Pb-Free package is recommended for new designs.

AC ELECTRICAL CHARACTERISTICS⁽¹⁾

V_{EE} = V_{EE} (Min.) to V_{EE} (Max.); V_{CC} = GND

Symbol	Parameter	TA = -40°C			TA = 0°C			TA = +25°C			TA = +85°C			Unit
		Min.	Typ.	Max.	Min.	Typ.	Max.	Min.	Typ.	Max.	Min.	Typ.	Max.	
f _{MAX}	Maximum Toggle Frequency	1000	—	—	1000	—	—	1000	—	—	1000	—	—	MHz
t _{PD}	Propagation Delay to Output													ps
	CLK → Output (Diff.)	950	—	1150	950	—	1150	970	—	1170	1050	—	1250	
	CLK → Output (S.E.)	900	—	1200	900	—	1200	920	—	1220	1000	—	1300	
	MR → Output	600	—	900	600	—	900	600	—	900	600	—	900	
t _{skew}	Within-Device Skew ⁽²⁾ Q ₀ — Q ₃			50			50			50			50	ps
	All	—	—	75	—	—	75	—	—	75	—	—	75	
	Part-to-Part Q ₀ — Q ₃ (Diff.)			200			200			200			200	
	All	—	—	240	—	—	240	—	—	240	—	—	240	
t _s	Set-up Time $\overline{EN} \rightarrow \overline{CLK}$	300	150	—	—	150	—	—	150	—	—	150	—	ps
	DIVSEL → CLK	300	—	—	—	—	—	—	—	—	—	—	—	
t _H	Hold Time $\overline{CLK} \rightarrow \overline{EN}$	400	150	—	400	150	—	400	150	—	400	150	—	ps
	CLK → DIVSEL	400	200	—	400	200	—	400	200	—	400	200	—	
V _{PP}	Minimum Input Swing ⁽³⁾ CLK	250	—	—	250	—	—	250	—	—	250	—	—	mV
V _{CMR}	Common Mode Range ⁽⁴⁾ CLK	-1.3	—	-0.4	-1.4	—	-0.4	-1.4	—	-0.4	-1.4	—	-0.4	V
t _{RR}	Reset Recovery Time	—	—	100	—	—	100	—	—	100	—	—	100	ps
t _{PW}	Minimum Pulse Width CLK	800	—	—	800	—	—	800	—	—	800	—	—	ps
	MR	700	—	—	700	—	—	700	—	—	700	—	—	
t _r t _f	Output Rise/Fall Times (20% — 80%) Q	280	—	550	280	—	550	280	—	550	280	—	550	ps

NOTES:

- Parametric values specified at:

5 volt Power Supply Range	100EL38 Series:	-4.2V to -5.5V.
	10EL38 Series	-4.75V to -5.5V.
3 volt Power Supply Range	10/100EL38L Series:	-3.0V to -3.8V.
- Skew is measured between outputs under identical transitions.
- Minimum input swing for which AC parameters are guaranteed. The device will function reliably with differential inputs down to 100mV.
- The CMR range is referenced to the most positive side of the differential input signal. Normal operation is obtained if the HIGH level falls within the specified range and the peak-to-peak voltage lies between V_{PP} min. and 1V. The lower end of the CMR range varies 1:1 with V_{EE}. The numbers in the spec table assume a nominal V_{EE} = -3.3V. Note for PECL operation, the V_{CMR} (min) will be fixed at 3.3V - |V_{CMR} (min)|.

LOGIC DIAGRAM

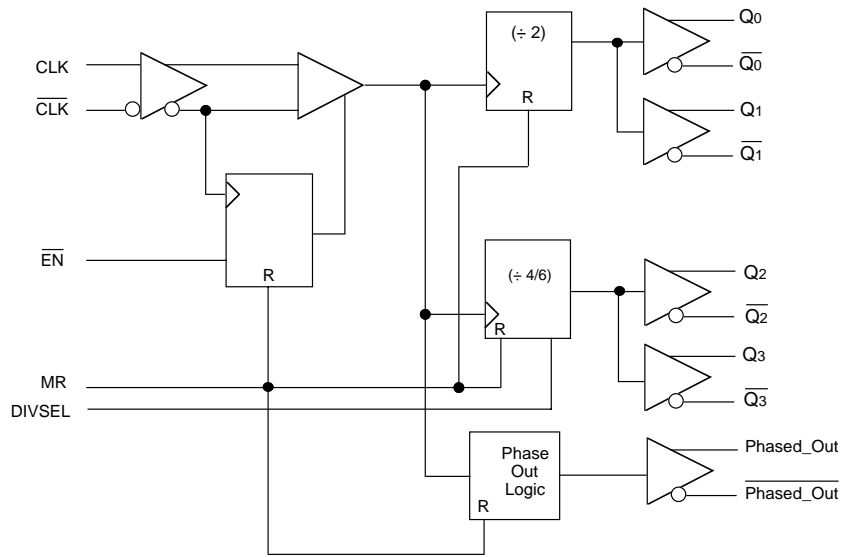

TIMING DIAGRAMS

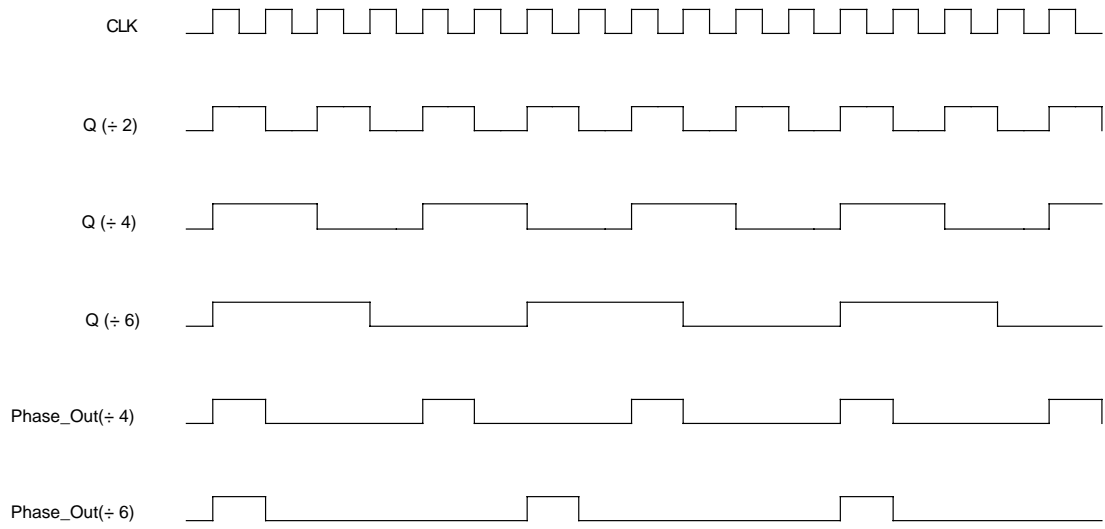

20-PIN SOIC .300" WIDE (Z20-1)

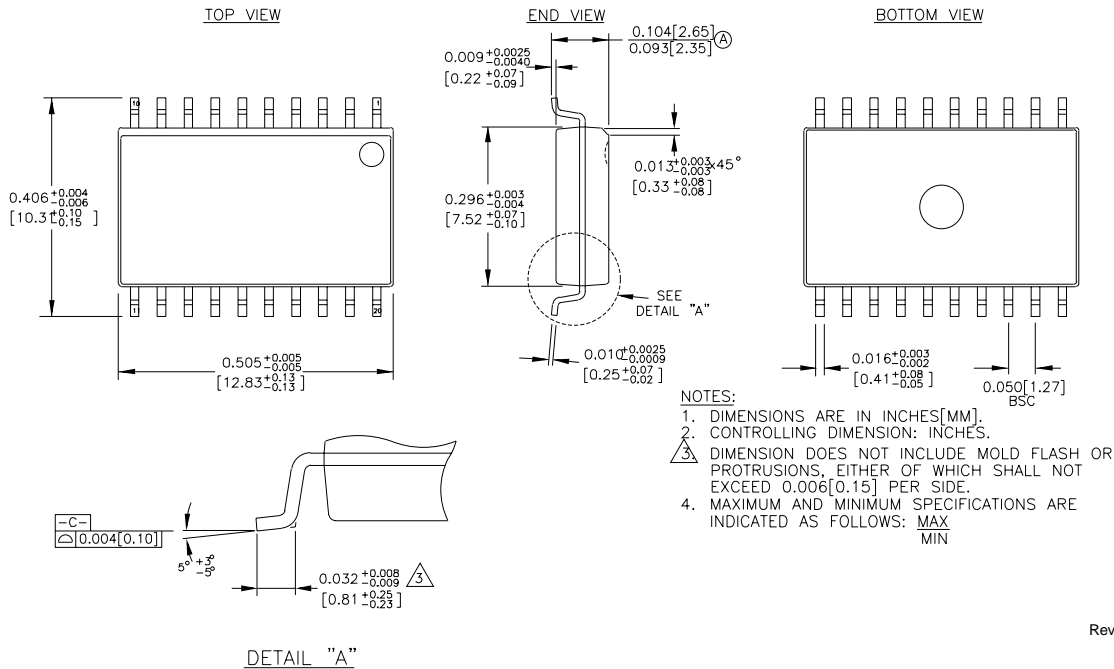

Rev. 03

MICREL, INC. 2180 FORTUNE DRIVE SAN JOSE, CA 95131 USA

TEL + 1 (408) 944-0800 FAX + 1 (408) 474-1000 WEB <http://www.micrel.com>

The information furnished by Micrel in this datasheet is believed to be accurate and reliable. However, no responsibility is assumed by Micrel for its use. Micrel reserves the right to change circuitry and specifications at any time without notification to the customer.

Micrel Products are not designed or authorized for use as components in life support appliances, devices or systems where malfunction of a product can reasonably be expected to result in personal injury. Life support devices or systems are devices or systems that (a) are intended for surgical implant into the body or (b) support or sustain life, and whose failure to perform can be reasonably expected to result in a significant injury to the user. A Purchaser's use or sale of Micrel Products for use in life support appliances, devices or systems is at Purchaser's own risk and Purchaser agrees to fully indemnify Micrel for any damages resulting from such use or sale.

© 2006 Micrel, Incorporated.