

# SY89846U



## 1.5GHz Precision, LVPECL 1:5 Fanout with 2:1 MUX and Fail Safe Input with Internal Termination

Precision Edge<sup>®</sup>

### General Description

The SY89846U is a 2.5/3.3V, 1:5 LVPECL fanout buffer with a 2:1 differential input multiplexer (MUX). A unique Fail-Safe Input (FSI) protection prevents metastable output conditions when the selected input clock fails to a DC voltage (voltage between the pins of the differential input drops significantly below 100mV).

The differential input includes Micrel's unique, 3-pin internal termination architecture that can interface to any differential signal (AC- or DC-coupled) as small as 100mV (200mV<sub>PP</sub>) without any level shifting or termination resistor networks in the signal path. The outputs are 800mV, LVPECL with fast rise/fall times guaranteed to be less than 250ps.

The SY89846U operates from a 2.5V ±5% or 3.3V ±10% supply and is guaranteed over the full industrial temperature range of -40°C to +85°C. The SY89846U is part of Micrel's high-speed, Precision Edge<sup>®</sup> product line.

All support documentation can be found on Micrel's web site at: [www.micrel.com](http://www.micrel.com).

### Functional Block Diagram

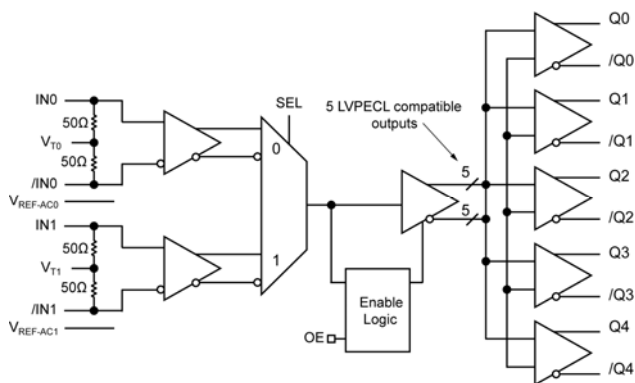

Precision Edge<sup>®</sup>

### Features

- Selects between two inputs, and provides 5 precision LVPECL copies
- Fail-Safe Input
  - Prevents outputs from oscillating when input is invalid
- Guaranteed AC performance over temperature and supply voltage:
  - DC-to >1.5GHz throughput
  - < 900ps Propagation Delay (IN-to-Q)
  - < 250ps Rise/Fall times
- Ultra-low jitter design:
  - <1ps<sub>RMS</sub> random jitter
  - <1ps<sub>RMS</sub> cycle-to-cycle jitter
  - <10ps<sub>PP</sub> total jitter (clock)
  - <0.7ps<sub>RMS</sub> MUX crosstalk induced jitter
- Unique, patented MUX input isolation design minimizes adjacent channel crosstalk
- Unique patented internal termination and VT pin accepts DC- and AC-coupled inputs (CML, PECL, LVDS)
- Wide input voltage range. VCC to GND
- 2.5V ±5% or 3.3V ±10% supply voltage
- -40°C to +85°C industrial temperature range
- Available in 32-pin (5mm x 5mm) MLF<sup>®</sup> package

### Applications

- Fail-safe clock protection
- SONET clock distribution
- Backplane distribution

### Markets

- LAN/WAN
- Enterprise servers
- ATE
- Test and measurement

Precision Edge is a registered trademark of Micrel, Inc.  
MLF and *MicroLeadFrame* are registered trademarks of Amkor Technology

Micrel Inc. • 2180 Fortune Drive • San Jose, CA 95131 • USA • tel +1 (408) 944-0800 • fax + 1 (408) 474-1000 • <http://www.micrel.com>

## Ordering Information<sup>(1)</sup>

Part Number	Package Type	Operating Range	Package Marking	Lead Finish
SY89846UMG	MLF-32	Industrial	SY89846U with Pb-Free bar-line Indicator	NiPdAu Pb-Free
SY89846UMGTR <sup>(2)</sup>	MLF-32	Industrial	SY89846U with Pb-Free bar-line Indicator	NiPdAu Pb-Free

**Notes:**

1. Contact factory for die availability. Dice are guaranteed at T<sub>A</sub> = 25°C, DC Electricals Only.
2. Tape and Reel.

## Pin Configuration

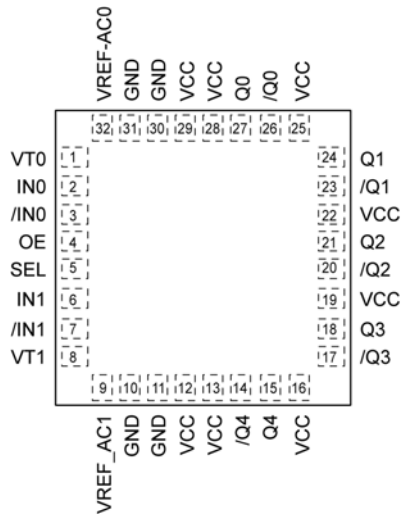

32-Pin MLF<sup>®</sup> (MLF-32)

## Pin Description

Pin Number	Pin Name	Pin Function
1,8	VT0, VT1	Input Termination Center-Tap: Each side of a differential input pair terminates to the VT pin. The VT pin provides a center-tap for each input (IN, /IN) to a termination network for maximum interface flexibility. See "Input Interface Applications" subsection.
2, 3 6, 7	IN0, /IN0 IN1, /IN1	Differential Inputs: These input pairs are the differential signal inputs to the device. These inputs accept AC- or DC-coupled signals as small as 100mV. The input pairs internally terminate to a VT pin through 50Ω. Each input has level shifting resistors of 3.72kΩ to VCC. This allows a wide input voltage range from VCC to GND. See Figure 3a, Simplified Differential Input Stage for details. Note that these inputs will default to a valid (either HIGH or LOW) state if left open. See "Input Interface Applications" subsection.
10, 11, 30, 31	GND, Exposed Pad	Ground. Exposed pad must be connected to a ground plane that is the same potential as the ground pins.
4	OE	Single-Ended Input: This TTL/CMOS input disables and enables the Q0-Q4 outputs. It is internally connected to a 25kΩ pull-up resistor and will default to a logic HIGH state if left open. When disabled, Q goes LOW and /Q goes HIGH. OE being synchronous, outputs will be enabled/disabled following a rising and a falling edge of the input clock. $V_{TH} = V_{CC}/2$ .
5	SEL	Single-Ended Input: This single-ended TTL/CMOS-compatible input selects the inputs to the multiplexer. Note that this input is internally connected to a 25kΩ pull-up resistor and will default to logic HIGH state if left open. $V_{TH} = V_{CC}/2$ .
9, 32	VREF-AC1 VREF-AC0	Reference Voltage: These outputs bias to $V_{CC}-1.2V$ . They are used for AC-coupling inputs IN and /IN. Connect VREF-AC directly to the corresponding VT pin. Bypass with 0.01μF low ESR capacitor to VCC. Due to limited drive capability, the VREF-AC pin is only intended to drive its respective VT pin. Maximum sink/source current is ±0.5mA. See "Input Interface Applications" subsection.
12, 13, 16, 19, 22, 25, 28, 29	VCC	Positive Power Supply: Bypass with 0.1μF  0.01μF low ESR capacitors as close to the VCC pins as possible.
27, 26 24, 23 21, 20 18, 17 15, 14	Q0, /Q0 Q1, /Q1 Q2, /Q2 Q3, /Q3 Q4, /Q4	LVPECL Differential Output Pairs: Differential buffered output copies of the selected input signal. The output swing is typically 800mV. Unused output pairs may be left floating with no impact on jitter. See "LVPECL Output Termination" subsection. Normally terminated with 50Ω to $V_{CC}-2V$ . These differential LVPECL outputs are a logic function of the IN0, IN1, and SEL inputs. See "Truth Table" below.

## Truth Table

Inputs					Outputs	
IN0	/IN0	IN1	/IN1	SEL	Q	/Q
0	1	X	X	0	0	1
1	0	X	X	0	1	0
X	X	0	1	1	0	1
X	X	1	0	1	1	0

**Absolute Maximum Ratings<sup>(1)</sup>**

Supply Voltage ( $V_{CC}$ )	.....	-0.5V to +4.0V
Input Voltage ( $V_{IN}$ )	.....	-0.5V to $V_{CC}$
LVPECL Output Current ( $I_{OUT}$ )		
Continuous	.....	50mA
Surge	.....	100mA
Current ( $V_T$ )		
Source or sink on $V_T$ pin	.....	$\pm 100$ mA
Input Current		
Source or sink current on ( $I_N$ , $/I_N$ )	.....	$\pm 50$ mA
Current ( $V_{REF}$ )		
Source or sink current on $V_{REF-AC}$ <sup>(4)</sup>	.....	$\pm 0.5$ mA
Maximum operating Junction Temperature	.....	125°C
Lead Temperature (soldering, 20sec.)	.....	260°C
Storage Temperature ( $T_s$ )	.....	-65°C to +150°C

**Operating Ratings<sup>(2)</sup>**

Supply Voltage ( $V_{CC}$ )	.....	+2.375V to +2.625V
	.....	+3.0V to +3.6V
Ambient Temperature ( $T_A$ )	.....	-40°C to +85°C
Package Thermal Resistance <sup>(3)</sup>		
MLF <sup>®</sup> ( $\theta_{JA}$ )		
Still-Air	.....	50°C/W
MLF <sup>®</sup> ( $\psi_{JB}$ )		
Junction-to-Board	.....	31°C/W

**DC Electrical Characteristics<sup>(5)</sup>**

$T_A = -40^\circ\text{C}$  to  $+85^\circ\text{C}$ , unless otherwise stated.

Symbol	Parameter	Condition	Min	Typ	Max	Units
$V_{CC}$	Power Supply Voltage		2.375	2.5	2.625	V
			3.0	3.3	3.6	V
$I_{CC}$	Power Supply Current	No load, max $V_{CC}$		60	75	mA
$R_{IN}$	Input Resistance (IN-to- $V_T$ )		45	50	55	$\Omega$
$R_{DIFF\_IN}$	Differential Input Resistance (IN-to- $/I_N$ )		90	100	110	$\Omega$
$V_{IH}$	Input HIGH Voltage (IN, $/I_N$ )		0.1		$V_{CC}$	V
$V_{IL}$	Input LOW Voltage (IN, $/I_N$ )		0		$V_{IH}-0.1$	V
$V_{IN}$	Input Voltage Swing (IN, $/I_N$ )	See Figure 2a. Note 6	0.1		1.0	V
$V_{DIFF\_IN}$	Differential Input Voltage Swing $ I_N-/-I_N $	See Figure 2b.	0.2		1.9	V
$V_{IN\_FSI}$	Input Voltage Threshold that Triggers FSI			30	100	mV
$V_{REF-AC}$	Output Reference Voltage	$I_{V_{REF-AC}} = \pm 0.5\text{mA}$	$V_{CC}-1.3$	$V_{CC}-1.2$	$V_{CC}-1.1$	V
$V_{T\_IN}$	Voltage from Input to $V_T$				1.28	V

**Notes:**

1. Permanent device damage may occur if absolute maximum ratings are exceeded. This is a stress rating only and functional operation is not implied at conditions other than those detailed in the operational sections of this data sheet. Exposure to absolute maximum rating conditions for extended periods may affect device reliability.
2. The data sheet limits are not guaranteed if the device is operated beyond the operating ratings.
3. Package thermal resistance assumes exposed pad is soldered (or equivalent) to the devices most negative potential on the PCB.  $\theta_{JA}$  and  $\psi_{JB}$  values are determined for a 4-layer board in still air unless otherwise stated.
4. Due to the limited drive capability, use for input of the same package only.
5. The circuit is designed to meet the DC specifications shown in the above table after thermal equilibrium has been established.
6.  $V_{IN}$  (max) is specified when  $V_T$  is floating.

## LVPECL Outputs DC Electrical Characteristics<sup>(7)</sup>

$V_{CC} = 2.5V \pm 5\%$  or  $3.3V \pm 10\%$ ;  $R_L = 50\Omega$  to  $V_{CC}-2V$ ;  $T_A = -40^\circ C$  to  $+85^\circ C$ , unless otherwise stated.

Symbol	Parameter	Condition	Min	Typ	Max	Units
$V_{OH}$	Output HIGH Voltage	Q, /Q	$V_{CC}-1.145$		$V_{CC}-0.895$	V
$V_{OL}$	Output LOW Voltage	Q, /Q	$V_{CC}-1.945$		$V_{CC}-1.695$	V
$V_{OUT}$	Output Voltage Swing	See Figure 2a.	550	800	950	mV
$V_{DIFF\_OUT}$	Differential Output Voltage Swing	See Figure 2b.	1100	1600		mV

## LVTTTL/CMOS DC Electrical Characteristics<sup>(7)</sup>

$V_{CC} = 2.5V \pm 5\%$  or  $3.3V \pm 10\%$ ;  $T_A = -40^\circ C$  to  $+85^\circ C$ , unless otherwise stated.

Symbol	Parameter	Condition	Min	Typ	Max	Units
$V_{IH}$	Input HIGH Voltage		2.0			V
$V_{IL}$	Input LOW Voltage				0.8	V
$I_{IH}$	Input HIGH Current		-125		30	$\mu A$
$I_{IL}$	Input LOW Current		-300			$\mu A$

**Note:**

7. The circuit is designed to meet the DC specifications shown in the above table after thermal equilibrium has been established.

## AC Electrical Characteristics <sup>(8)</sup>

$V_{CC} = 2.5V \pm 5\%$  or  $3.3V \pm 10\%$ ;  $R_L = 50\Omega$  to  $V_{CC}-2V$ ; Input  $t_r/t_f \leq 300ps$ ;  $T_A = -40^\circ C$  to  $+85^\circ C$ , unless otherwise stated.

Symbol	Parameter	Condition	Min	Typ	Max	Units
$f_{MAX}$	Maximum Operating Frequency	$V_{OUT} \geq 400mV, V_{IN} \geq 200mV$	1.5	2.0		GHz
		$V_{OUT} \geq 400mV, V_{IN} \geq 100mV$	1.0	1.5		GHz
$t_{pd}$	Differential Propagation Delay					
	IN-to-Q	$100mV < V_{IN} \leq 200mV$ , Note 9	600	850	1100	ps
	IN-to-Q	$200mV < V_{IN} \leq 800mV$ , Note 9	400	700	900	ps
	SEL-to-Q	$V_{TH} = V_{CC}/2$	350	600	800	ps
$t_s$ OE	Set-up Time	OE-to-IN	Note 10			ps
$t_h$ OE	Hold Time	IN-to-OE	Note 10			ps
$t_{SKEW}$	Output-to-Output Skew	Note 11		7	20	ps
	Input-to-Input Skew	Note 12		5	15	ps
	Part-to-Part Skew	Note 13			300	ps
$t_{JITTER}$	Clock					
	Random Jitter	Note 14			1	$\mu s_{RMS}$
	Cycle-to-Cycle Jitter	Note 15			1	$\mu s_{RMS}$
	Total Jitter	Note 16			10	$\mu s_{PP}$
	Crosstalk-Induced Jitter	Note 17			0.7	$\mu s_{RMS}$
$t_r, t_f$	Output Rise/Fall Time (20% to 80%)	At full output swing.	110	170	250	ps
	Duty Cycle	$V_{IN} > 200mV$	47		53	%
		$100mV < V_{IN} \leq 200mV$	45		55	%

### Notes:

- High-frequency AC-parameters are guaranteed by design and characterization.
- Propagation delay is measured with input  $t_r, t_f \leq 300ps$  (20% to 80%). The propagation delay is a function of the rise and fall times at IN. See "Typical Operating Characteristics" for details.
- Set-up and hold times apply to synchronous applications that intend to enable/disable before the next clock cycle. For asynchronous applications, set-up and hold do not apply.
- Output-to-Output skew is measured between two different outputs under identical transitions.
- Input-to-Input skew is the time difference between the two inputs to one output, under identical input transitions.
- Part-to-Part skew is defined for two parts with identical power supply voltages at the same temperature and with no skew of the edges at the respective inputs.
- Random Jitter is measured with a K28.7 character pattern, measured at  $<f_{MAX}$ .
- Cycle-to-Cycle Jitter definition: the variation of periods between adjacent cycles,  $T_n - T_{n-1}$  where T is the time between rising edges of the output signal.
- Total Jitter definition: with an ideal clock input of frequency  $<f_{MAX}$ , no more than one output edge in  $10^{12}$  output edges will deviate by more than the specified peak-to-peak jitter value.
- Crosstalk is measured at the output while applying two similar differential clock frequencies that are asynchronous with respect to each other at the inputs.

## Functional Description

### Clock Select (SEL)

SEL is an asynchronous TTL/CMOS compatible input that selects one of the two input signals. An internal 25k $\Omega$  pull-up resistor defaults the input to logic HIGH if left open. Input switching threshold is  $V_{CC}/2$ . Refer to Figure 1a.

### Fail-Safe Input (FSI)

The input includes a special fail-safe circuit to sense the amplitude of the input signal and to latch the outputs when there is no input signal present, or when the amplitude of the input signal drops sufficiently below 100mV<sub>PK</sub> (200mV<sub>PP</sub>), typically 30mV<sub>PK</sub>. Maximum frequency of the SY89846U is limited by the FSI function. Refer to Figure 1b.

### Input Clock Failure Case

If the input clock fails to a floating, static, or extremely low signal swing such that the voltage swing across the input pair is significantly less than 100mV, FSI function will eliminate a metastable condition and latch the outputs to the last valid state. No ringing and no undetermined state will occur at the output under these conditions. The output recovers to normal operation once the input signal returns to a valid state with a typical swing greater than 30mV.

Note that the FSI function will not prevent duty cycle distortion in case of a slowly deteriorating (but still toggling) input signal. Due to the FSI function, the propagation delay will depend on rise and fall time of the input signal and on its amplitude. Refer to "Typical Operating Characteristics" for detailed information.

### Output Enable (OE)

OE is a synchronous TTL/CMOS compatible input that enables/disables the outputs based on the input to this pin. The enable function is synchronous so that the clock outputs will be enabled or disabled following a rising and a falling edge of the input clock. Refer to Figure 1c. Internal 25k $\Omega$  pull-up resistor defaults the input to logic HIGH if left open. Input switching threshold is  $V_{CC}/2$ .

### Timing Diagrams

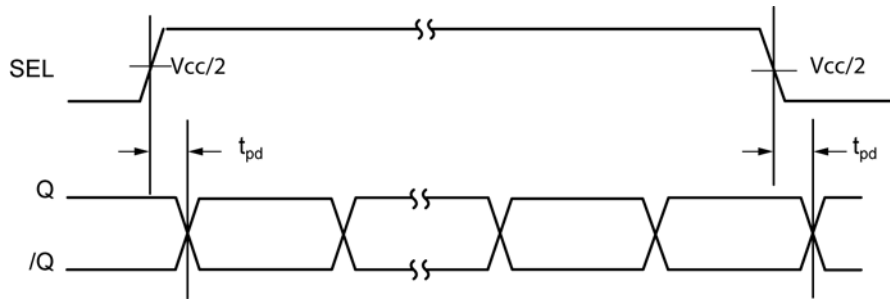

Figure 1a. SEL-to-Q Delay

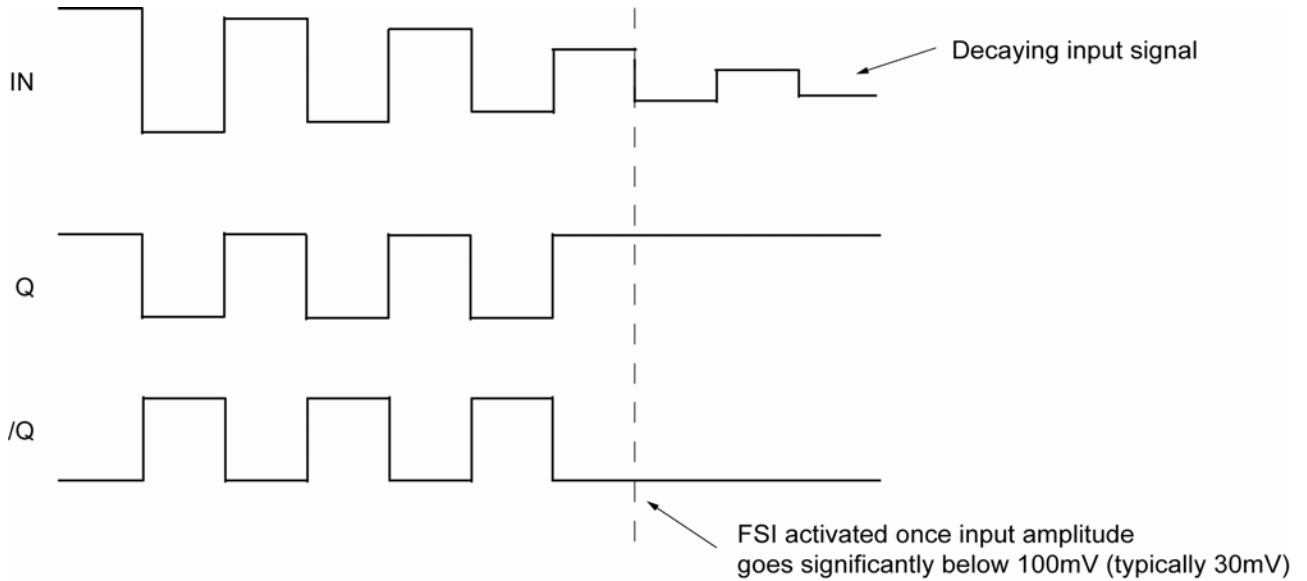

Figure 1b. Fail Safe Feature

### Timing Diagrams (Continued)

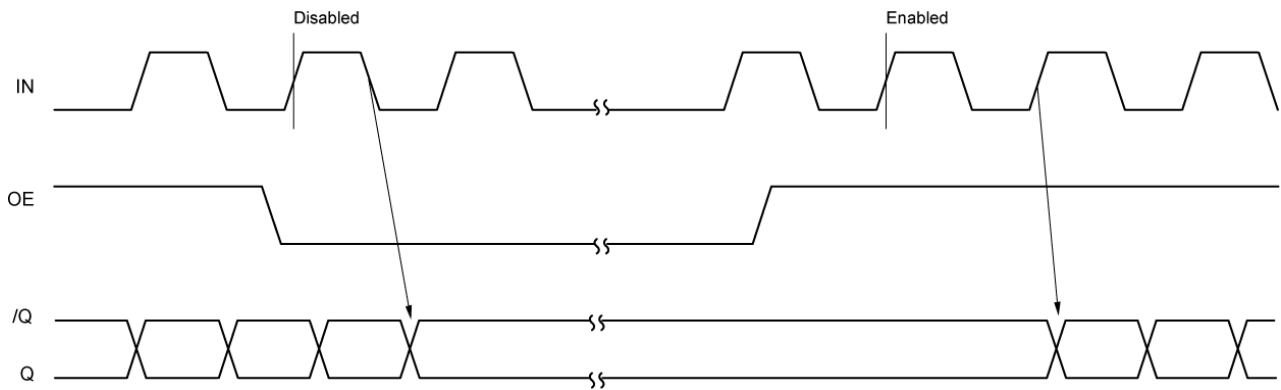

Figure 1c. Enable Output Timing Diagram

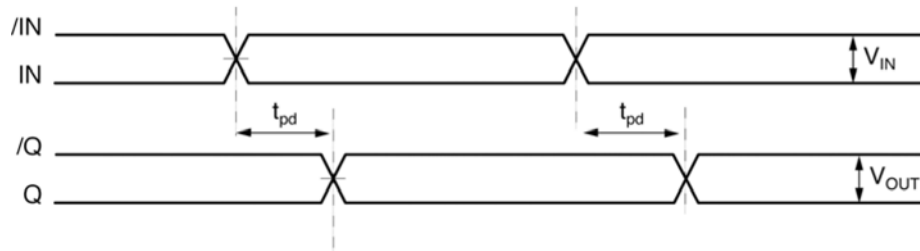

Figure 1d. Propagation Delay

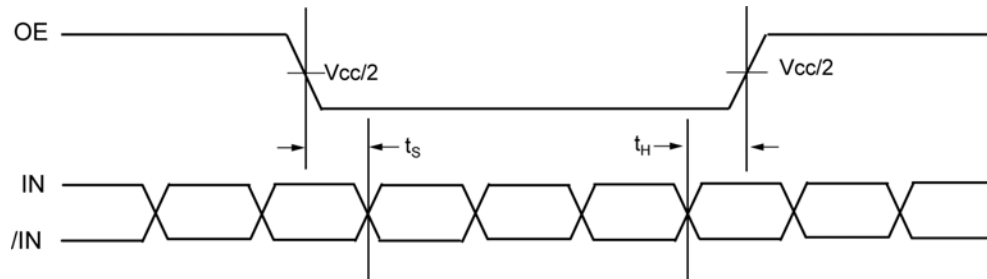
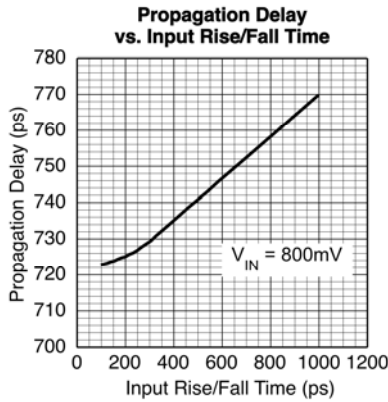
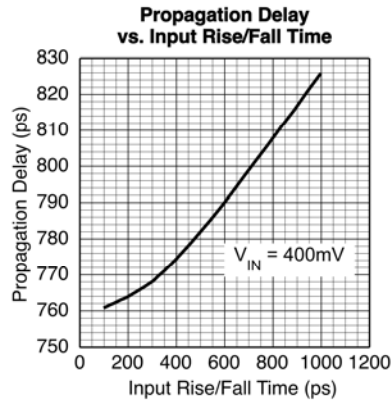
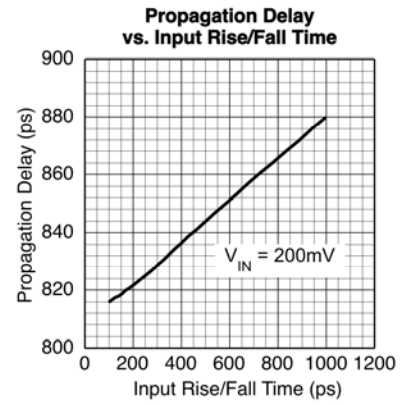
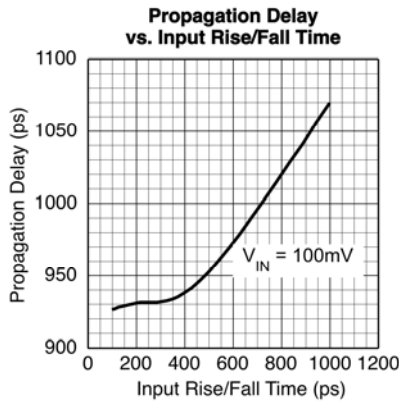
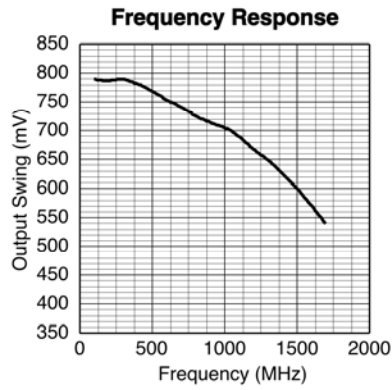

Figure 1e. Setup and Hold Time

## Typical Operating Characteristics

$V_{CC} = 3.3V$ ,  $GND = 0V$ ,  $t_r / t_f \leq 300ps$ ,  $V_{IN} = 100mV$ ,  $R_L = 50\Omega$  to  $V_{CC}-2V$ ;  $T_A = 25^\circ C$ , unless otherwise stated.



## Functional Characteristics

$V_{CC} = 3.3V$ ,  $GND = 0V$ ,  $V_{IN} \geq 400mV$ ,  $t_r/t_f \leq 300ps$ ,  $R_L = 50\Omega$  to  $V_{CC}-2V$ ;  $T_A = 25^\circ C$ , unless otherwise stated.

**200MHz Clock**

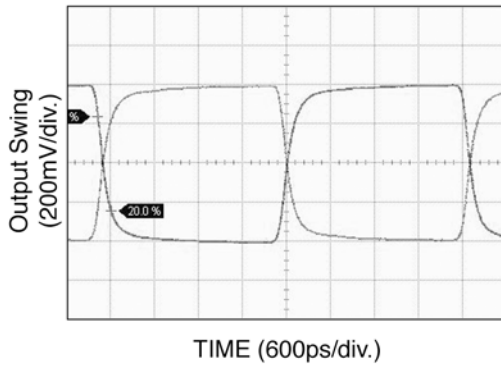

**500MHz Clock**

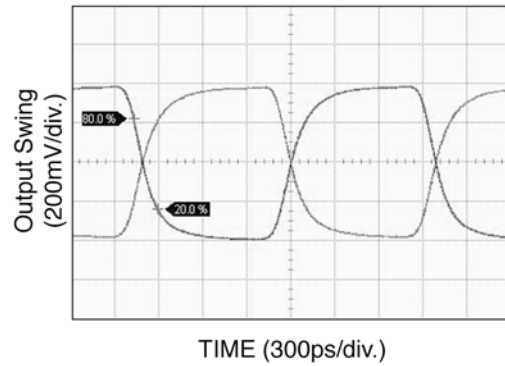

**1GHz Clock**

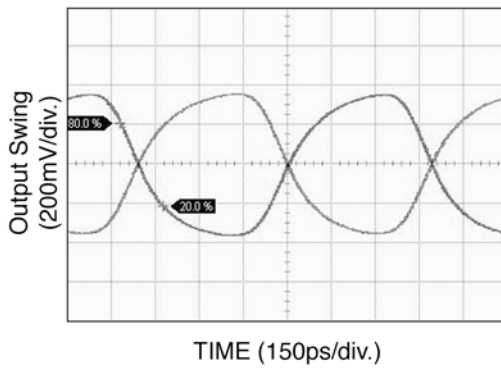

**1.5GHz Clock**

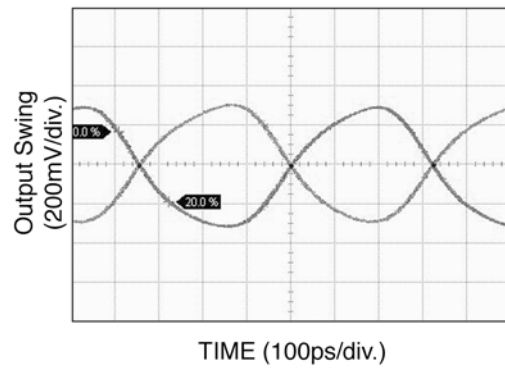

## Single-Ended and Differential Swings

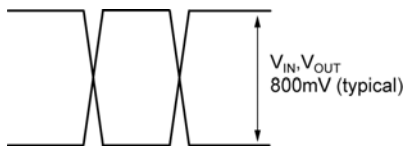

Figure 2a. Single-Ended Voltage Swing

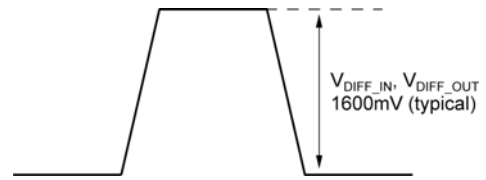

Figure 2b. Differential Voltage Swing

## Input and Output Stages

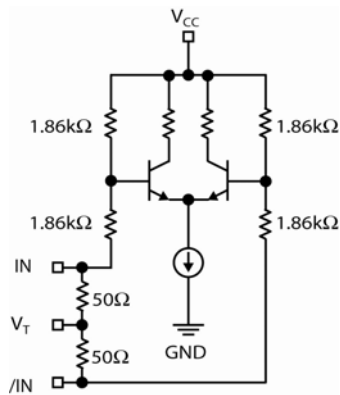

Figure 3a. Simplified Differential Input Stage

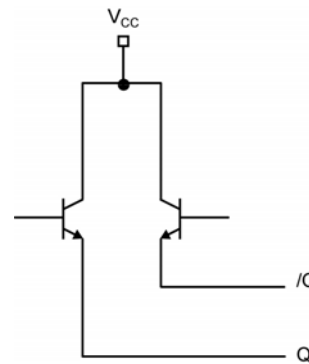

Figure 3b. Simplified Differential Output Stage

## Input Interface Applications

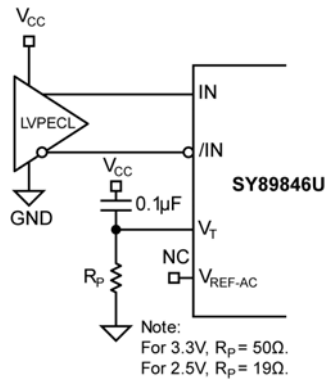

Figure 4a. LVPECL Interface (DC-Coupled)

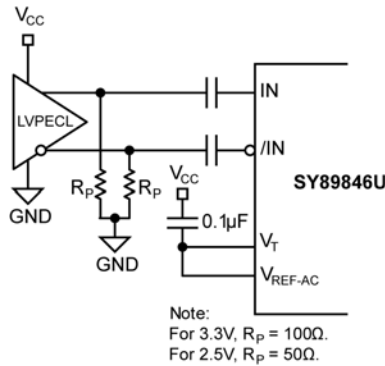
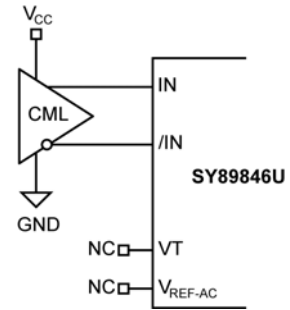

Figure 4b. LVPECL Interface (AC-Coupled)



Option: may connect  $V_T$  to  $V_{CC}$

Figure 4c. CML Interface (DC-Coupled)

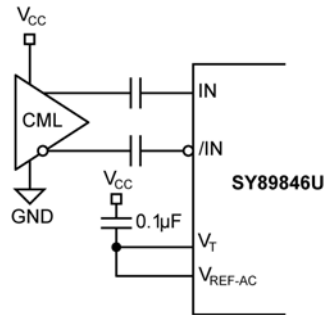

Figure 4d. CML Interface (AC-Coupled)

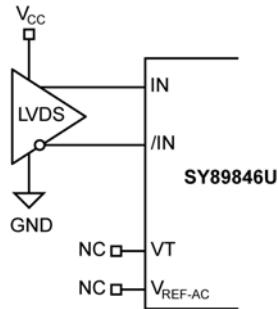
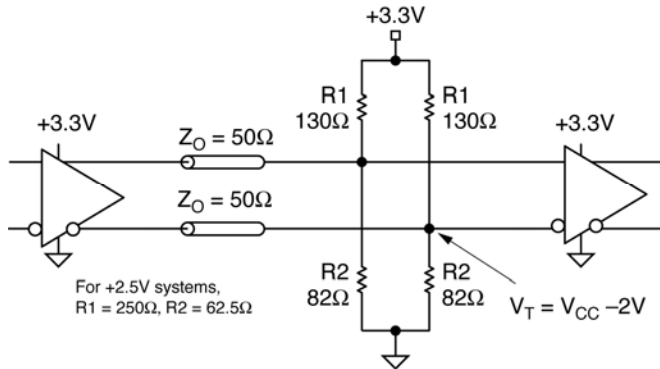

Figure 4e. LVDS Interface (DC-Coupled)

## PECL Output Interface Applications

PECL has a high input impedance, a very low output impedance (open emitter), and a small signal swing which results in low EMI. PECL is ideal for driving 50Ω- and 100Ω-controlled impedance transmission lines. There are several techniques for terminating the PECL output: parallel termination-thevenin equivalent, parallel termination (3-resistor), and AC-coupled termination. Unused output pairs may be left floating. However, single-ended outputs must be terminated, or balanced.



**Figure 5a. Parallel Termination-Thevenin Equivalent**

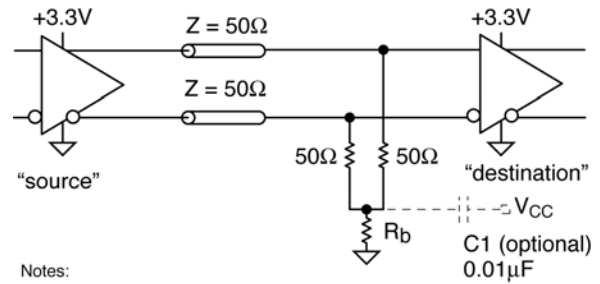

- Notes:
1. Power-saving alternative to Thevenin termination.
  2. Place termination resistors as close to destination inputs as possible.
  3.  $R_b$  resistor sets the DC bias voltage, equal to  $V_T$ .
  4. For 2.5V systems,  $R_b = 19\Omega$ , For 3.3V systems,  $R_b = 50\Omega$

**Figure 5b. Parallel Termination (3-Resistor)**

## Related Product and Support Documentation

Part Number	Function	Data Sheet Link
SY89847U	Precision LVDS 1 :5 Fanout with 2 :1 MUX and Fail-Safe Input with Internal Termination	<a href="http://www.micrel.com/product-info/products/sy89847u.shtml">www.micrel.com/product-info/products/sy89847u.shtml</a> .
	MLF® Application Note	<a href="http://www.amkor.com/products/notes_papers/MLFAppNote.pdf">www.amkor.com/products/notes_papers/MLFAppNote.pdf</a>
HBW Solutions	New Products and Applications	<a href="http://www.micrel.com/product-info/products/solutions.shtml">www.micrel.com/product-info/products/solutions.shtml</a>

### Package Information

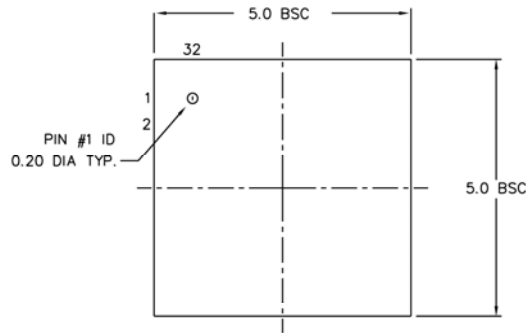

TOP VIEW

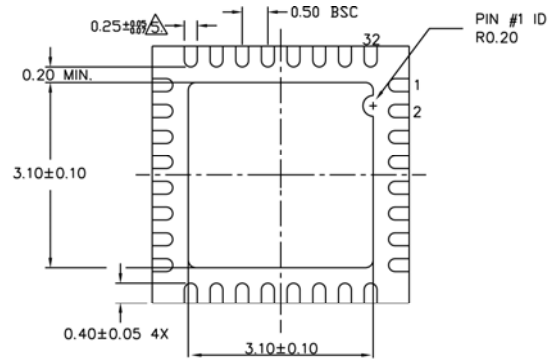

BOTTOM VIEW

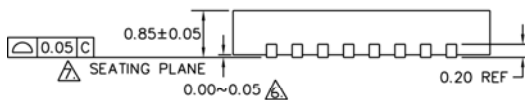

SIDE VIEW

NOTE:  
 1. ALL DIMENSIONS ARE IN MILLIMETERS.  
 2. MAX. PACKAGE WARPAGE IS 0.05 mm.  
 3. MAXIMUM ALLOWABLE BURRS IS 0.076 mm IN ALL DIRECTIONS.  
 4. PIN #1 ID ON TOP WILL BE LASER/INK MARKED.  
 DIMENSION APPLIES TO METALIZED TERMINAL AND IS MEASURED BETWEEN 0.20 AND 0.25 mm FROM TERMINAL TIP.  
 APPLIED ONLY FOR TERMINALS.  
 APPLIED FOR EXPOSED PAD AND TERMINALS.

### 32-Pin (5mm x 5mm) MLF<sup>®</sup>

#### Packages Notes:

1. Package meets Level 2 Moisture Sensitivity Classification.
2. All parts are dry-packed before shipment.
3. Exposed pad must be soldered to a ground for proper thermal management.

**MICREL, INC. 2180 FORTUNE DRIVE SAN JOSE, CA 95131 USA**  
 TEL +1 (408) 944-0800 FAX +1 (408) 474-1000 WEB <http://www.micrel.com>

The information furnished by Micrel in this data sheet is believed to be accurate and reliable. However, no responsibility is assumed by Micrel for its use. Micrel reserves the right to change circuitry and specifications at any time without notification to the customer.

Micrel Products are not designed or authorized for use as components in life support appliances, devices or systems where malfunction of a product can reasonably be expected to result in personal injury. Life support devices or systems are devices or systems that (a) are intended for surgical implant into the body or (b) support or sustain life, and whose failure to perform can be reasonably expected to result in a significant injury to the user. A Purchaser's use or sale of Micrel Products for use in life support appliances, devices or systems is a Purchaser's own risk and Purchaser agrees to fully indemnify Micrel for any damages resulting from such use or sale.

© 2006 Micrel, Inc.