



**ULTRA-PRECISION 1:4 LVPECL
FANOUT BUFFER/TRANSLATOR
WITH INTERNAL TERMINATION**

**Precision Edge®
SY89831U**

FEATURES

- **Guaranteed AC performance over temperature and voltage:**
 - DC-to >2.0GHz throughput
 - <450ps propagation delay (IN-to-Q)
 - <20ps within-device skew
 - <225ps rise/fall time
- **Ultra-low jitter design:**
 - <62fs RMS phase jitter (Typ)
- **Unique patent-pending input termination and VT pin accepts DC- and AC-coupled differential inputs**
- **800mV, 100K LVPECL output swing**
- **Power supply 2.5V ±5% or 3.3V ±10%**
- **Industrial temperature range: -40°C to +85°C**
- **Available in 16-pin (3mm x 3mm) MLF® package**



Precision Edge®

DESCRIPTION

The SY89831U is a high-speed, 2GHz differential LVPECL 1:4 fanout buffer optimized for ultra-low skew applications. Within device skew is guaranteed to be less than 20ps (5ps typ.) over supply voltage and temperature. The differential input buffer has a unique internal termination design that allows access to the termination network through a VT pin. This feature allows the device to easily interface to different logic standards. A VREF-AC reference output is included for AC-coupled applications.

The SY89831U is a part of Micrel's high-speed clock synchronization family. For applications that require a different I/O combination, consult Micrel's website at: www.micrel.com, and choose from a comprehensive product line of high-speed, low-skew fanout buffers, translators and clock generators.

APPLICATIONS

- **Processor clock distribution**
- **SONET clock distribution**
- **Fibre Channel clock distribution**
- **Gigabit Ethernet clock distribution**

FUNCTIONAL BLOCK DIAGRAM

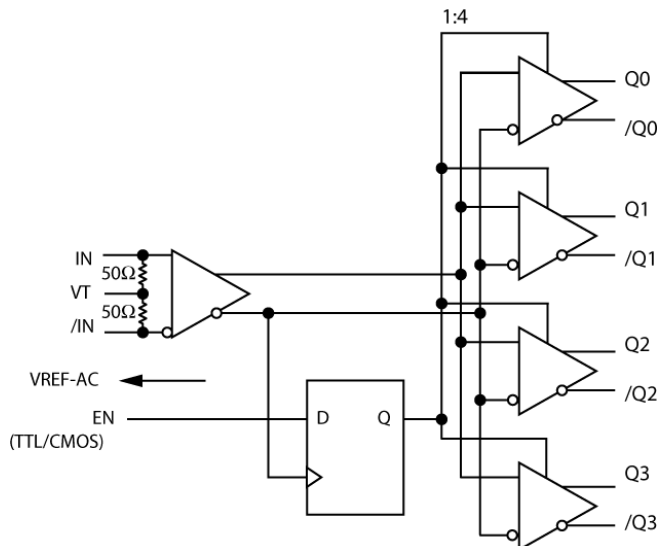

TYPICAL PERFORMANCE

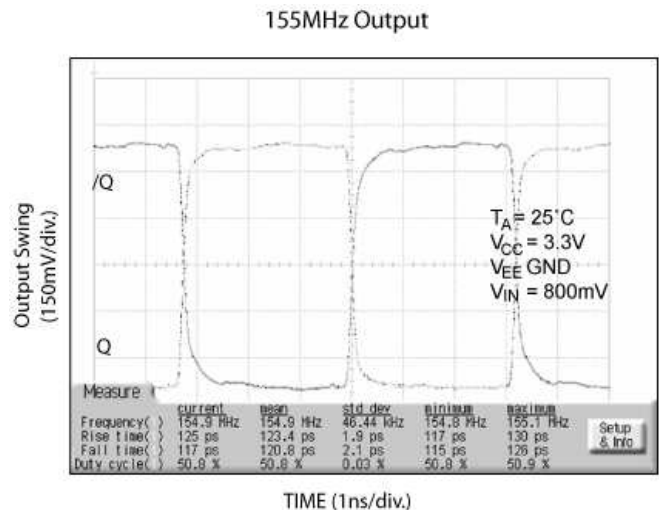

Precision Edge is a registered trademark of Micrel, Inc.
MicroLeadFrame and MLF are registered trademarks of Amkor Technology, Inc.

PACKAGE/ORDERING INFORMATION

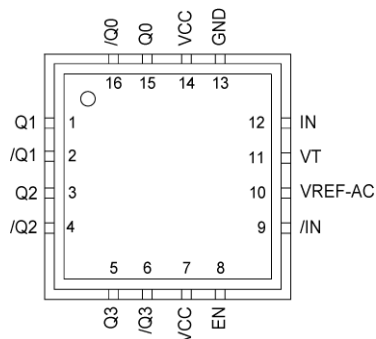

16-Pin MLF® (MLF-16)

Ordering Information(1)

Part Number	Package Type	Operating Range	Package Marking	Lead Finish
SY89831UMI	MLF-16	Industrial	831U	Sn-Pb
SY89831UMITR ⁽²⁾	MLF-16	Industrial	831U	Sn-Pb
SY89831UMG ⁽³⁾	MLF-16	Industrial	831U with Pb-Free bar-line indicator	NiPdAu Pb-Free
SY89831UMGTR ^(2, 3)	MLF-16	Industrial	831U with Pb-Free bar-line indicator	NiPdAu Pb-Free

Notes:

1. Contact factory for die availability. Dice are guaranteed at $T_A = 25^\circ\text{C}$, DC Electricals only.
2. Tape and Reel.
3. Pb-Free package is recommended for new designs.

PIN DESCRIPTION

Pin Number	Pin Name	Pin Function
15, 16 1, 2, 3, 4, 5, 6	Q0, /Q0 Q1, /Q1 Q2, /Q2 Q3, /Q3	Differential 100K LVPECL Outputs: These LVPECL outputs are the precision, low skew copies of the inputs. Please refer to the "Truth Table" section for details. Unused output pairs may be left open. Terminate with 50Ω to $V_{CC}-2V$. See "Output Termination Recommendations" section for more details.
8	EN	This single-ended TTL/CMOS-compatible input functions as a synchronous output enable. The synchronous enable ensures that enable/disable will only occur when the outputs are in a logic LOW state. Note that this input is internally connected to a $25k\Omega$ pull-up resistor and will default to logic HIGH state (enabled) if left open.
9, 12	/IN, IN	Differential Inputs: These input pairs are the differential signal inputs to the device. Inputs accept AC- or DC-Coupled differential signs as small as 100mV. Each pin of a pair internally terminates to a VT pin through 50Ω . Note that these inputs will default to an intermediate state if left open. Please refer to the "Input Interface Applications" section for more details.
10	VREF-AC	Reference Voltage: These outputs bias to $V_{CC}-1.4V$. They are used when AC coupling the inputs (IN, /IN). For AC-Coupled applications, connect VREF-AC to VT pin and bypass with $0.01\mu\text{F}$ low ESR capacitor to V_{CC} . See "Input Interface Applications" section for more details. Maximum sink/source current is $\pm 1.5\text{mA}$. Due to the limited drive capability, each VREF-AC pin is only intended to drive its respective VT pin. If VREF-AC is used with a 2.5V supply, make sure input swing is large enough to not violate V_{IH} min. spec.
11	VT	Input Termination Center-Tap: Each side of the differential input pair terminates to a VT pin. The VT pins provide a center-tap to a termination network for maximum interface flexibility. See "Input Interface Applications" section for more details.
13	GND	Ground. GND pins and exposed pad must be connected to the most negative potential of the device ground.
7, 14	VCC	Positive Power Supply: Bypass with $0.1\mu\text{F}/0.01\mu\text{F}$ low ESR capacitors and place as close to each VCC pin as possible.

TRUTH TABLE

IN	/IN	EN	Q	/Q
0	1	1	0	1
1	0	1	1	0
X	X	0	0 ⁽¹⁾	1 ⁽¹⁾

Note:

1. On next negative transition of the input signal (IN).

Absolute Maximum Ratings⁽¹⁾

Supply Voltage (V_{CC}).....	-0.5V to +4.0V
Input Voltage (V_{IN}).....	-0.5V to $V_{CC}+0.5V$
LVPECL Output Current (I_{OUT})	
Continuous.....	50mA
Surge	100mA
Input Current	
Source or Sink Current on (IN, /IN).....	±50mA
VREF-AC Current	
Source or Sink Current on (I_{VT}).....	±2mA
Lead Temperature (soldering, 20sec.).....	260°C
Storage Temperature (T_S)	-65°C to +150°C

Operating Ratings⁽²⁾

Supply Voltage Range	+2.375V to +2.625V
.....	+3.0V to +3.6V
Ambient Temperature (T_A).....	-40°C to +85°C
Package Thermal Resistance ⁽³⁾	
MLF™	
(θ_{JA}) Still-Air	60°C/W
(Ψ_{JB}) Junction-to-Board	32°C/W

DC ELECTRICAL CHARACTERISTICS⁽⁴⁾

$T_A = -40^\circ\text{C}$ to $+85^\circ\text{C}$, unless otherwise stated.

Symbol	Parameter	Condition	Min	Typ	Max	Units
V_{CC}	Power Supply		2.375 3.0		2.625 3.6	V
I_{CC}	Power Supply Current	No load, max. V_{CC} .		47	70	mA
R_{IN}	Input Resistance (IN-to-VT)		45	50	55	Ω
$R_{DIFF-IN}$	Differential Input Resistance (IN-to-/IN)		90	100	110	Ω
V_{IH}	Input HIGH Voltage (IN, /IN)		1.2		V_{CC}	V
V_{IL}	Input LOW Voltage (IN, /IN)		0		$V_{IH}-0.1$	V
V_{IN}	Input Voltage Swing (IN, /IN)	see Figure 1a.	0.1		1.7	V
V_{DIFF_IN}	Differential Input Voltage Swing $ IN - /IN $	see Figure 1b.	0.2			V
V_{REF-AC}	Output Reference Voltage		$V_{CC}-1.525$	$V_{CC}-1.425$	$V_{CC}-1.325$	V

LVTTTL/LVCMOS INPUT DC ELECTRICAL CHARACTERISTICS

$V_{CC} = 2.375V$ to $3.60V$; $V_{EE} = 0V$; $T_A = -40^\circ\text{C}$ to $+85^\circ\text{C}$

Symbol	Parameter	Condition	Min	Typ	Max	Units
V_{IH}	Input HIGH Voltage		2.0		V_{CC}	V
V_{IL}	Input LOW Voltage		0		0.8	V
I_{IH}	Input HIGH Current		-125		20	μA
I_{IL}	Input LOW Current		-300			μA

Notes:

1. Permanent device damage may occur if absolute maximum ratings are exceeded. This is a stress rating only and functional operation is not implied at conditions other than those detailed in the operational sections of this data sheet. Exposure to absolute maximum rating conditions for extended periods may affect device reliability.
2. The data sheet limits are not guaranteed if the device is operated beyond the operating ratings.
3. Package thermal resistance assumes exposed pad is soldered (or equivalent) to the device's most negative potential on the PCB. Ψ_{JB} and θ_{JA} values are determined for a 4-layer board in stil-air number, unless otherwise stated.
4. The circuit is designed to meet the DC specifications shown in the above table after thermal equilibrium has been established.

LVPECL OUTPUT DC ELECTRICAL CHARACTERISTICS⁽⁶⁾

$V_{CC} = +2.5V \pm 5\%$ or $+3.3V \pm 10\%$; $R_L = 50\Omega$ to $V_{CC} - 2V$; $T_A = -40^\circ C$ to $+85^\circ C$ unless otherwise stated.

Symbol	Parameter	Condition	Min	Typ	Max	Units
V_{OH}	Output HIGH Voltage (Q, /Q)		$V_{CC} - 1.145$		$V_{CC} - 0.895$	V
V_{OL}	Output LOW Voltage (Q, /Q)		$V_{CC} - 1.945$		$V_{CC} - 1.695$	V
V_{OUT}	Output Voltage Swing (Q, /Q)	See Figure 1a.	550	800		mV
V_{DIFF_OUT}	Differential Output Voltage Swing (Q, /Q)	See Figure 1b.	1100	1600		mV

LVTTTL/CMOS DC ELECTRICAL CHARACTERISTICS⁽⁶⁾

$V_{CC} = +2.5V \pm 5\%$ or $+3.3V \pm 10\%$; $T_A = -40^\circ C$ to $+85^\circ C$ unless otherwise stated.

Symbol	Parameter	Condition	Min	Typ	Max	Units
V_{IH}	Input HIGH Voltage		2.0		V_{CC}	V
V_{IL}	Input LOW Voltage				0.8	V
I_{IH}	Input HIGH Voltage		-125		30	μA
I_{IL}	Input LOW Voltage		-300			μA

Notes:

6. The circuit is designed to meet the DC specifications shown in the above table after thermal equilibrium has been established.

AC ELECTRICAL CHARACTERISTICS(7)

$V_{CC} = +2.5V \pm 5\%$ or $+3.3V \pm 10\%$; $R_L = 50\Omega$ to $V_{CC} - 2V$; $T_A = -40^\circ C$ to $+85^\circ C$ unless otherwise stated.

Symbol	Parameter	Condition	Min	Typ	Max	Units
f_{MAX}	Maximum Frequency	$V_{OUT} \geq 450mV$	2.0	2.5		GHz
t_{pd}	Propagation Delay	IN-to-Q $V_{IN} \geq 100mV$		390		ps
		IN-to-Q $V_{IN} \geq 800mV$	250	350	450	ps
t_{SKEW}	Within-Device Skew	Note 8		5	20	ps
	Part-to-Part Skew	Note 9			150	ps
t_S	Set-Up Time	EN to IN, /IN Note 10	300			ps
t_H	Hold Time	EN to IN, /IN Note 10	300			ps
t_{JITTER}	RMS Phase Jitter	Output = 622MHz Integration Range 12kHz - 20MHz		62		fs
t_r, t_f	Output Rise/Fall Times (20% to 80%)	At full output swing.	70	150	225	ps

Notes:

7. High-frequency AC parameters are guaranteed by design and characterization.
8. Within device skew is measured between two different outputs under identical input transitions.
9. Part-to-part skew is defined for two parts with identical power supply voltages at the same temperature and no skew at the edges at the respective inputs.
10. Set-up and hold times apply to synchronous applications that intend to enable/disable before the next clock cycle. For asynchronous applications, set-up and hold times do not apply.

PHASE NOISE

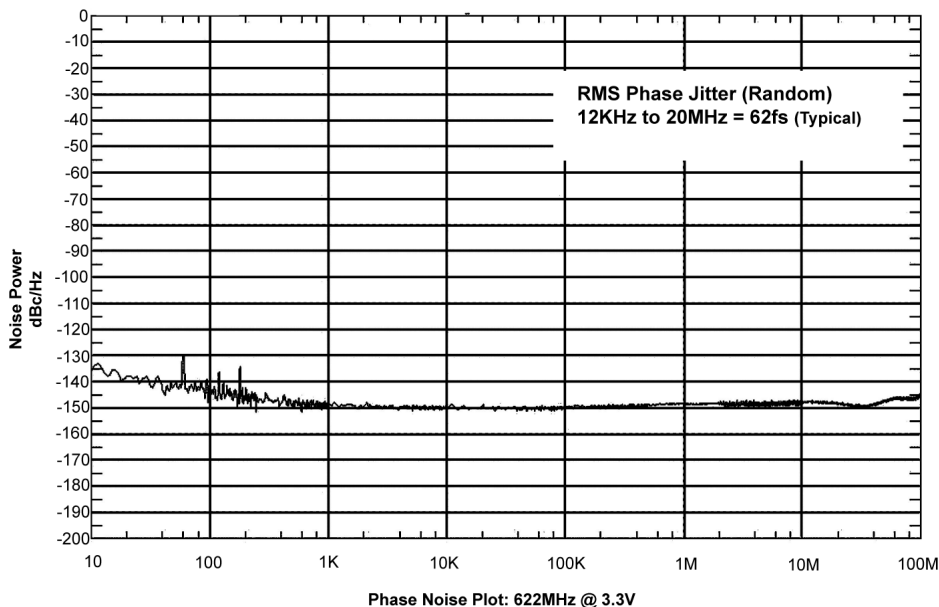

TYPICAL OPERATING CHARACTERISTICS

$V_{CC} = 3.3V$, $GND = 0V$, $R_L = 50\Omega$ to $V_{CC}-2V$, $T_A = 25^\circ C$, unless otherwise stated.

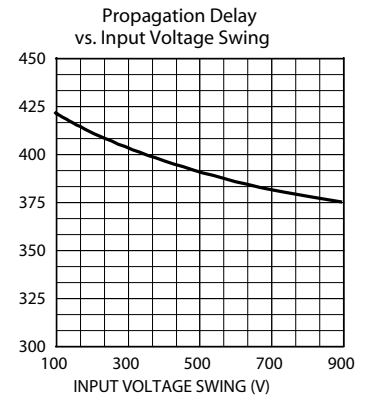
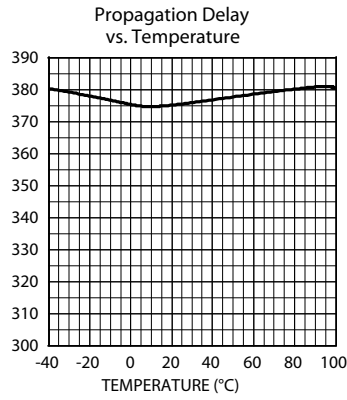
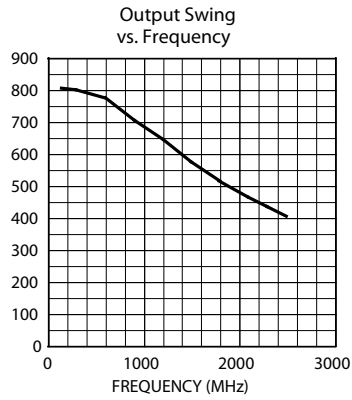

FUNCTIONAL CHARACTERISTICS

$V_{CC} = 3.3V$, $GND = 0V$, $V_{IN} = 800mV$, $R_L = 50\Omega$ to $V_{CC} - 2V$, $T_A = 25^\circ C$, unless otherwise stated.

155MHz Output

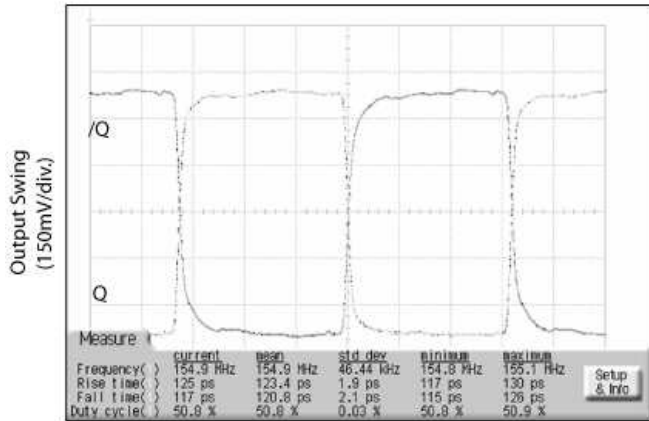

TIME (1ns/div.)

622MHz Output

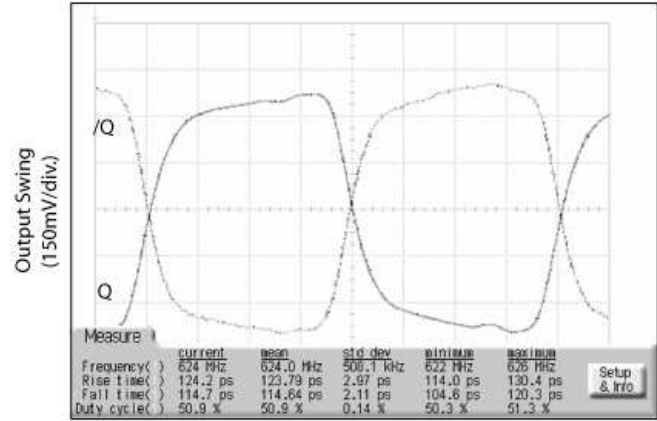

TIME (200ps/div.)

1GHz Output

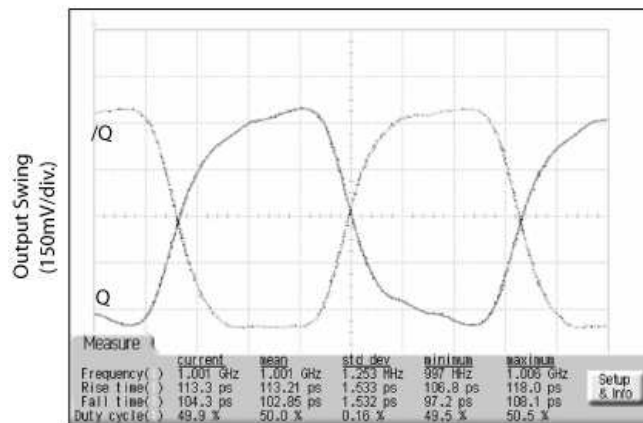

TIME (150ps/div.)

SINGLE-ENDED AND DIFFERENTIAL SWINGS

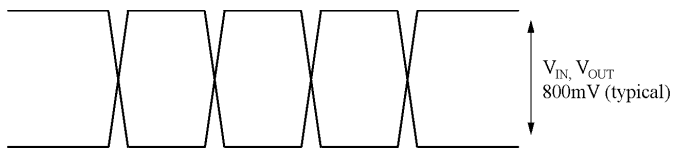

Figure 1a. Single-Ended Swing

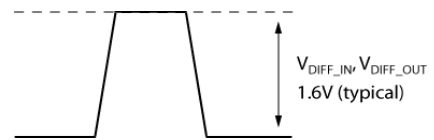

Figure 1b. Differential Swing

INPUT AND OUTPUT STAGES

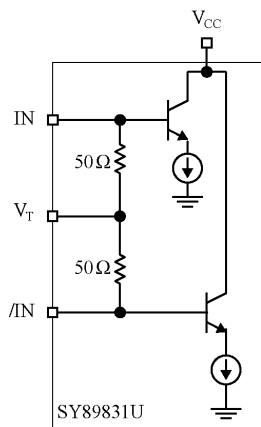

Figure 2a. Simplified Differential

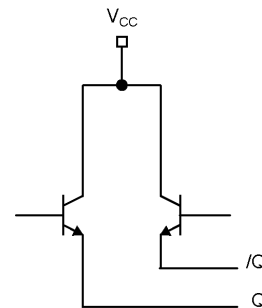

Figure 2b. Simplified LVPECL Output Stage

INPUT INTERFACE APPLICATIONS

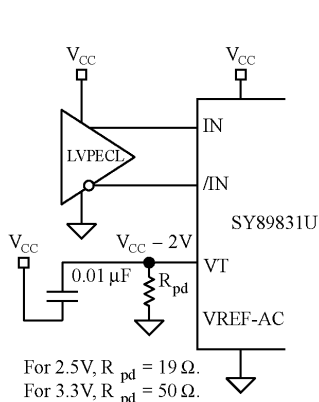

Figure 3a. DC-Coupled LVPECL Input Interface

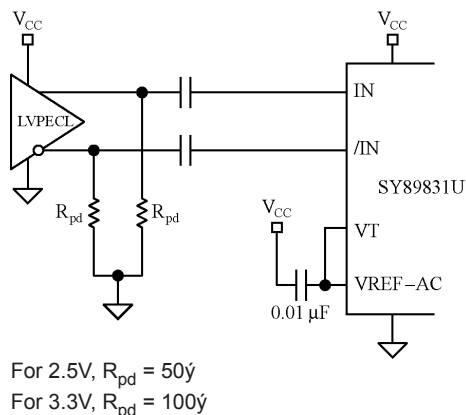

Figure 3b. AC-Coupled LVPECL Input Interface

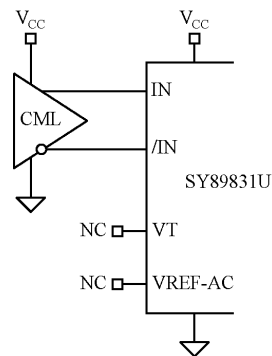

Figure 3c. DC-Coupled CML Input Interface

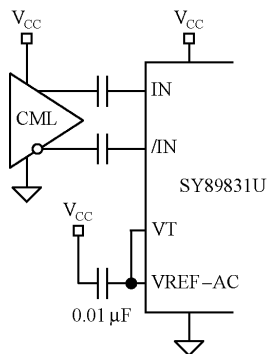

Figure 3d. AC-Coupled CML Input Interface

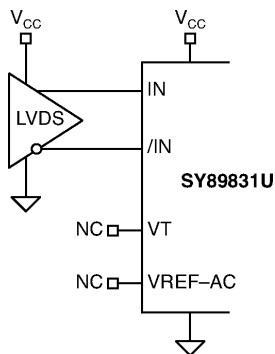

Figure 3e. LVDS Interface

OUTPUT TERMINATION RECOMMENDATIONS

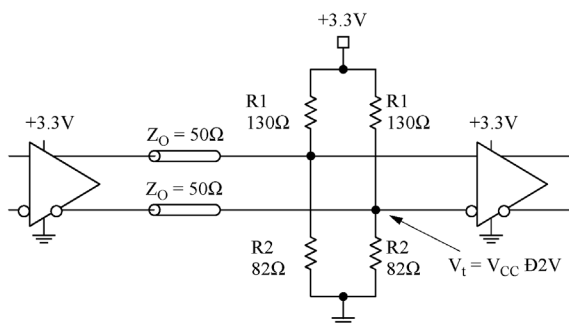

Figure 4. Parallel Termination—
Thevenin Equivalent

Note:

- For +2.5V systems: $R_1 = 250\Omega$, $R_2 = 62.5\Omega$.

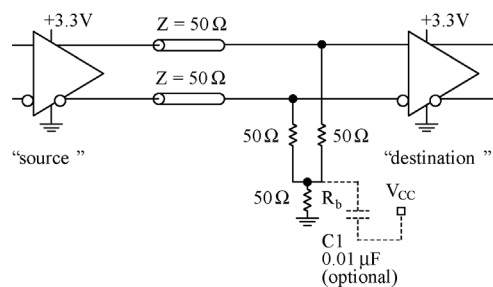

Figure 5. Three-Resistor "Y-Termination"

Notes:

- Power-saving alternative to Thevenin termination.
- Place termination resistors as close to destination inputs as possible.
- R_b resistor sets the DC bias voltage, equal to V_t .
For +2.5V systems $R_b = 19\Omega$.
- C_1 is an optional bypass capacitor intended to compensate for any t_r/t_f mismatches.

RELATED PRODUCT AND SUPPORT DOCUMENTATION

Part Number	Function	Data Sheet Link
SY89830U	1:4 LVPECL Fanout Buffer w/2:1 MUX Input	www.micrel.com/product-info/products/sy89830u.shtml
SY89832U	2.5V Ultra-Precision 1:4 LVDS Fanout Buffer/Translator with Internal Termination	www.micrel.com/product-info/products/sy89832u.shtml
SY89833U	3.3V Ultra-Precision 1:4 LVDS Fanout Buffer/Translator with Internal Termination	www.micrel.com/product-info/products/sy89833u.shtml
SY89834U	2.5/3.3V Two Input, 1GHz LVTTTL/CMOS-to-LVPECL 1:4 Fanout Buffer/Translator	www.micrel.com/product-info/products/sy89833u.shtml
HBW Solutions	New Products and Applications	www.micrel.com/product-info/products/solutions.shtml
	16-MLF® Manufacturing Guidelines Exposed Pad Application Note	www.amkor.com/products/notes_papers/MLF_AppNote_0301.pdf

16-PIN EPAD *MicroLeadFrame*® (MLF-16)

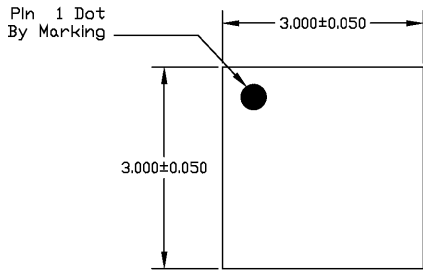

TOP VIEW

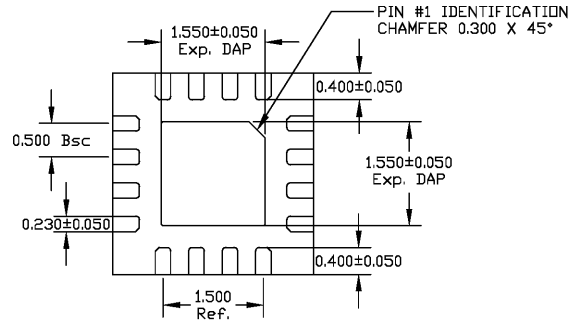

BOTTOM VIEW



SIDE VIEW

- NOTE:
1. ALL DIMENSIONS ARE IN MILLIMETERS.
 2. MAX. PACKAGE WARPAGE IS 0.05 mm.
 3. MAXIMUM ALLOWABLE BURRS IS 0.076 mm IN ALL DIRECTIONS.
 4. PIN #1 ID ON TOP WILL BE LASER/INK MARKED.

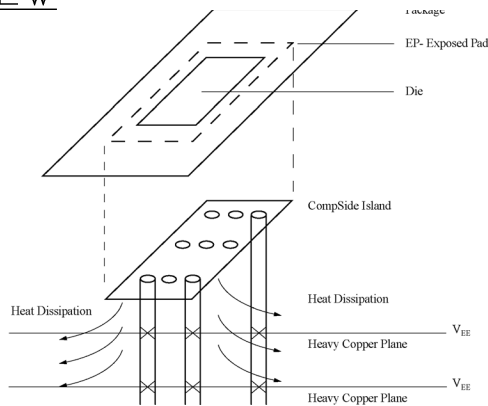

PCB Thermal Consideration for 16-Pin MLF® Package

(Always solder, or equivalent, the exposed pad to the PCB)

Package Notes:

- Note 1.** Package meets Level 2 moisture sensitivity classification, and are shipped in dry-pack form.
- Note 2.** Exposed pads must be soldered to a ground for proper thermal management.

MICREL, INC. 2180 FORTUNE DRIVE SAN JOSE, CA 95131 USA

TEL + 1 (408) 944-0800 FAX + 1 (408) 474-1000 WEB <http://www.micrel.com>

The information furnished by Micrel in this datasheet is believed to be accurate and reliable. However, no responsibility is assumed by Micrel for its use. Micrel reserves the right to change circuitry and specifications at any time without notification to the customer.

Micrel Products are not designed or authorized for use as components in life support appliances, devices or systems where malfunction of a product can reasonably be expected to result in personal injury. Life support devices or systems are devices or systems that (a) are intended for surgical implant into the body or (b) support or sustain life, and whose failure to perform can be reasonably expected to result in a significant injury to the user. A Purchaser's use or sale of Micrel Products for use in life support appliances, devices or systems is at Purchaser's own risk and Purchaser agrees to fully indemnify Micrel for any damages resulting from such use or sale.

© 2005 Micrel, Incorporated.