



7GHz, 1:2 CML FANOUT BUFFER/TRANSLATOR WITH INTERNAL I/O TERMINATION

Precision Edge®
SY58011U

FEATURES

- Precision 1:2, 400mV CML fanout buffer
- Low jitter performance:
 - 49fs_{RMS} phase jitter (typ)
- Guaranteed AC performance over temperature/ voltage:
 - $> 7\text{GHz } f_{\text{MAX}}$ clock
 - $< 60\text{ps } t / t_f$ times
 - $< 250\text{ps } t_{\text{pd}}$
 - $< 15\text{ps}$ max. skew
- Accepts an input signal as low as 100mV
- Unique input termination and V_T pin accepts DC-coupled and AC-coupled differential inputs: LVPECL, LVDS, and CML
- 50ohms source terminated CML outputs
- Power supply 2.5V $\pm 5\%$ and 3.3V $\pm 10\%$
- Industrial temperature range: -40°C to $+85^\circ\text{C}$
- Available in 16-pin (3mm * 3mm) QFN package



Precision Edge®

DESCRIPTION

The SY58011U is a 2.5V/3.3V precision, high-speed, fully differential 1:2 CML fanout buffer. Optimized to provide two identical output copies with less than 15ps of skew and only 49fs_{RMS} phase jitter, the SY58011U can process clock signals as fast as 7GHz or data patterns up to 10.7Gbps.

The differential input includes Micrel's unique, 3-pin input termination architecture that interfaces to LVPECL, LVDS, or CML differential signals, (AC-coupled or DC-coupled) as small as 100mV without any level-shifting or termination resistor networks in the signal path. For AC-coupled input interface applications, an on-board output reference voltage ($V_{\text{REF-AC}}$) is provided to bias the V_T pin. The outputs are compatible with 400mV typical swing into 50ohms loads, with extremely fast rise/fall times guaranteed to be less than 60ps.

The SY58011U operates from a 2.5V $\pm 5\%$ supply or 3.3V $\pm 10\%$ supply and is guaranteed over the full industrial temperature range (-40°C to $+85^\circ\text{C}$). For applications that require LVPECL outputs, consider the SY58012U or SY58013U 1:2 fanout buffer with 800mV and 400mV output swing, respectively. The SY58011U is part of Micrel's high-speed, Precision Edge® product line. Datasheets and support documentation can be found on Micrel's web site at www.micrel.com.

APPLICATIONS

- All SONET and GigE clock distribution
- Fibre Channel clock and data distribution
- Backplanes
- Data distribution: OC-48, OC-48+FEC, XAUI
- High-end, low skew, multiprocessor synchronous clock distribution

FUNCTIONAL BLOCK DIAGRAM

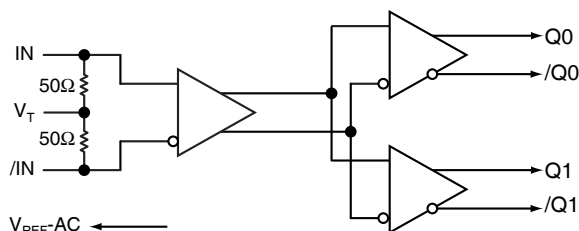

TYPICAL PERFORMANCE

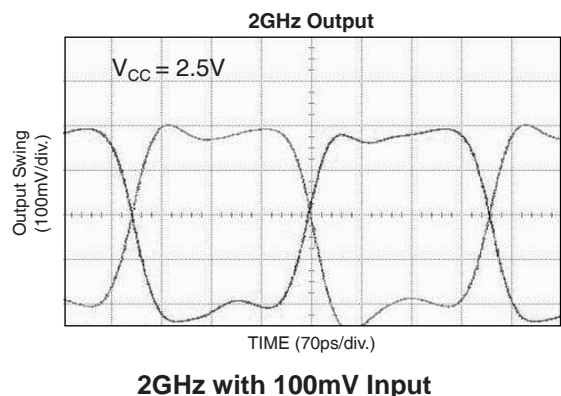

PACKAGE/ORDERING INFORMATION

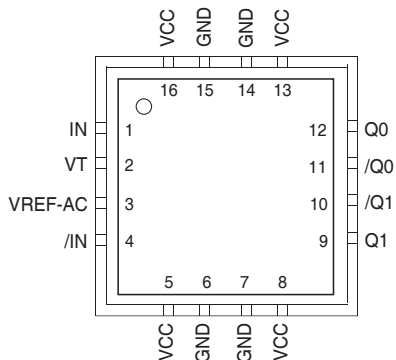

16-Pin QFN (QFN-16)

Ordering Information⁽¹⁾

Part Number	Package Type	Operating Range	Package Marking
SY58011UMG ⁽³⁾	QFN-16 Pb-Free	Industrial	011U with Pb-Free bar-line indicator
SY58011UMGTR ^(2, 3)	QFN-16 Pb-Free	Industrial	011U with Pb-Free bar-line indicator

Notes:

1. Contact factory for die availability. Dice are guaranteed at $T_A = 25^\circ\text{C}$, DC electricals only. All devices are Pb-Free.
2. Tape and Reel.
3. Pb-Free package recommended for new designs.

PIN DESCRIPTION

Pin Number	Pin Name	Pin Function
1, 4	IN, /IN	Differential Input: This input pair is the signal to be buffered. Each pin of this pair internally terminates with 50ohms to the V_T pin. Note that this input will default to an indeterminate state if left open. See <i>“Input Interface Applications”</i> section.
2	VT	Input Termination Center-Tap: Each input terminates to this pin. The V_T pin provides a center-tap for each input (IN, /IN) to a termination network for maximum interface flexibility. See <i>“Input Interface Applications”</i> section.
3	VREF-AC	Reference Output Voltage: This output biases to $V_{CC} - 1.2V$. It is used when AC-coupling the inputs (IN, /IN). Connect V_{REF-AC} directly to the V_T pin. Bypass with 0.01 μF low ESR capacitor to V_{CC} . Maximum current source or sink is 0.5mA. See <i>“Input Interface Applications”</i> section.
5, 8, 13, 16	VCC	Positive Power Supply: Bypass with 0.1 μF //0.01 μF low ESR capacitors as close to the V_{CC} pins as possible.
6, 7, 14, 15	GND, (Exposed Pad)	Ground. Exposed pad must be connected to a ground plane that is the same potential as the ground pin.
12, 11 9, 10	Q0, /Q0, Q1, /Q1	CML Differential Output Pairs: Differential buffered output copy of the input signal. The output swing is typically 400mV. Unused output pairs may be left floating with no impact on jitter. See <i>“CML Output Termination”</i> section.

Absolute Maximum Ratings(Note 1)

Power Supply Voltage (V_{CC}) -0.5V to +4.0V
 Input Voltage (V_{IN}) -0.5V to V_{CC}
 CML Output Voltage (V_{OUT}) $V_{CC}-1.0V$ to $V_{CC}+0.5V$
 Current (V_T)
 Source or sink current on V_T pin $\pm 100mA$
 Input Current
 Source or sink current on IN, /IN $\pm 50mA$
 Current (V_{REF})
 Source or sink current on V_{REF-AC} , **Note 4** $\pm 1.5mA$
 Lead Temperature Soldering, (20 seconds) 260°C
 Storage Temperature Range (T_{STORE}) ... -65°C to +150°C

Operating Ratings(Note 2)

Supply Voltage (V_{CC}) +2.375V to +3.60V
 Operating Temperature Range (T_A) -40°C to +85°C
 Package Thermal Resistance, **Note 3**
 QFN (θ_{JA})
 Still-Air 60°C/W
 500lfpm 54°C/W
 QFN (ψ_{JB}) 33°C/W

DC ELECTRICAL CHARACTERISTICS(Note 5)

$T_A = -40^\circ C$ to $+85^\circ C$

Symbol	Parameter	Condition	Min	Typ	Max	Units
V_{CC}	Power Supply Voltage		2.375		3.60	V
I_{CC}	Power Supply Current	Max. V_{CC} , no load		75	95	mA
V_{IH}	Input HIGH Voltage	IN, /IN, Note 6	$V_{CC}-1.6$		V_{CC}	V
V_{IL}	Input LOW Voltage	IN, /IN	0		$V_{IH}-0.1$	V
V_{IN}	Input Voltage Swing	see Figure 1a.	0.1		1.7	V
V_{DIFF_IN}	Differential Input Voltage Swing	see Figure 1b.	0.2			V
R_{IN}	Into V_T Resistance		40	50	60	Ω
V_{REF-AC}	Output Reference Voltage		$V_{CC}-1.3$	$V_{CC}-1.2$	$V_{CC}-1.1$	V
IN to V_T					1.28	V

CML DC ELECTRICAL CHARACTERISTICS(Note 5)

$V_{CC} = 3.3V \pm 10\%$ or $2.5V \pm 5\%$; $T_A = -40^\circ C$ to $+85^\circ C$; $R_L = 100\Omega$ across each output pair, or equivalent, unless otherwise stated.

Symbol	Parameter	Condition	Min	Typ	Max	Units
V_{OH}	Output HIGH Voltage	Q0, /Q0, Q1, /Q1	$V_{CC}-0.020$	$V_{CC}-0.010$	V_{CC}	V
V_{OUT}	Output Voltage Swing	Q0, /Q0, Q1, /Q1; see Figure 1a.	325	400		mV
V_{DIFF_OUT}	Differential Output Voltage Swing	Q0, /Q0, Q1, /Q1; see Figure 1b.	650	800		mV
R_{OUT}	Output Source Impedance	Q0, /Q0, Q1, /Q1	40	50	60	ohms

Notes:

1. Permanent device damage may occur if absolute maximum ratings are exceeded. This is a stress rating only and functional operation is not implied at conditions other than those detailed in the operational sections of this data sheet. Exposure to absolute maximum ratings conditions for extended periods may affect device reliability.
2. The data sheet limits are not guaranteed if the device is operated beyond the operating ratings.
3. Thermal performance assumes exposed pad is soldered (or equivalent) to the device's most negative potential (gnd) on the pcb.
4. Due to the limited drive capability, use for input of the same package only.
5. The circuit is designed to meet the dc specifications shown in the above table after thermal equilibrium has been established.
6. V_{IH} (min) not lower than 1.2V.

AC ELECTRICAL CHARACTERISTICS (Note 7)

$V_{CC} = 2.5V \pm 5\%$ or $3.3V \pm 10\%$; $T_A = -40^{\circ}C$ to $+85^{\circ}C$; $R_L = 100\Omega$ across each output pair, or equivalent, unless otherwise stated.

Symbol	Parameter	Condition	Min	Typ	Max	Units
f_{MAX}	Maximum Operating Frequency	NRZ Data		10.7		Gbps
		$V_{OUT} > 200mV$ Clock	7	8		GHz
t_{pd}	Propagation Delay	$V_{IN} > 100mV$	100	170	250	ps
t_{CHAN}	Channel-to-Channel Skew	Note 8		3	15	ps
t_{SKEW}	Part-to-Part Skew	Note 9			100	ps
t_{JITTER}	RMS Phase Jitter	Output = 622MHz Integration Range: 12kHz - 20MHz		49		fs _{RMS}
t_r, t_f	Output Rise/Fall Time	20% to 80% at full output swing	20	40	60	ps

Notes:

- 7. High frequency AC electricals are guaranteed by design and characterization.
- 8. Skew is measured between outputs of the same bank under identical transitions.
- 9. Skew is defined for two parts with identical power supply voltages at the same temperature and with no skew of the edges at the respective inputs.

PHASE NOISE

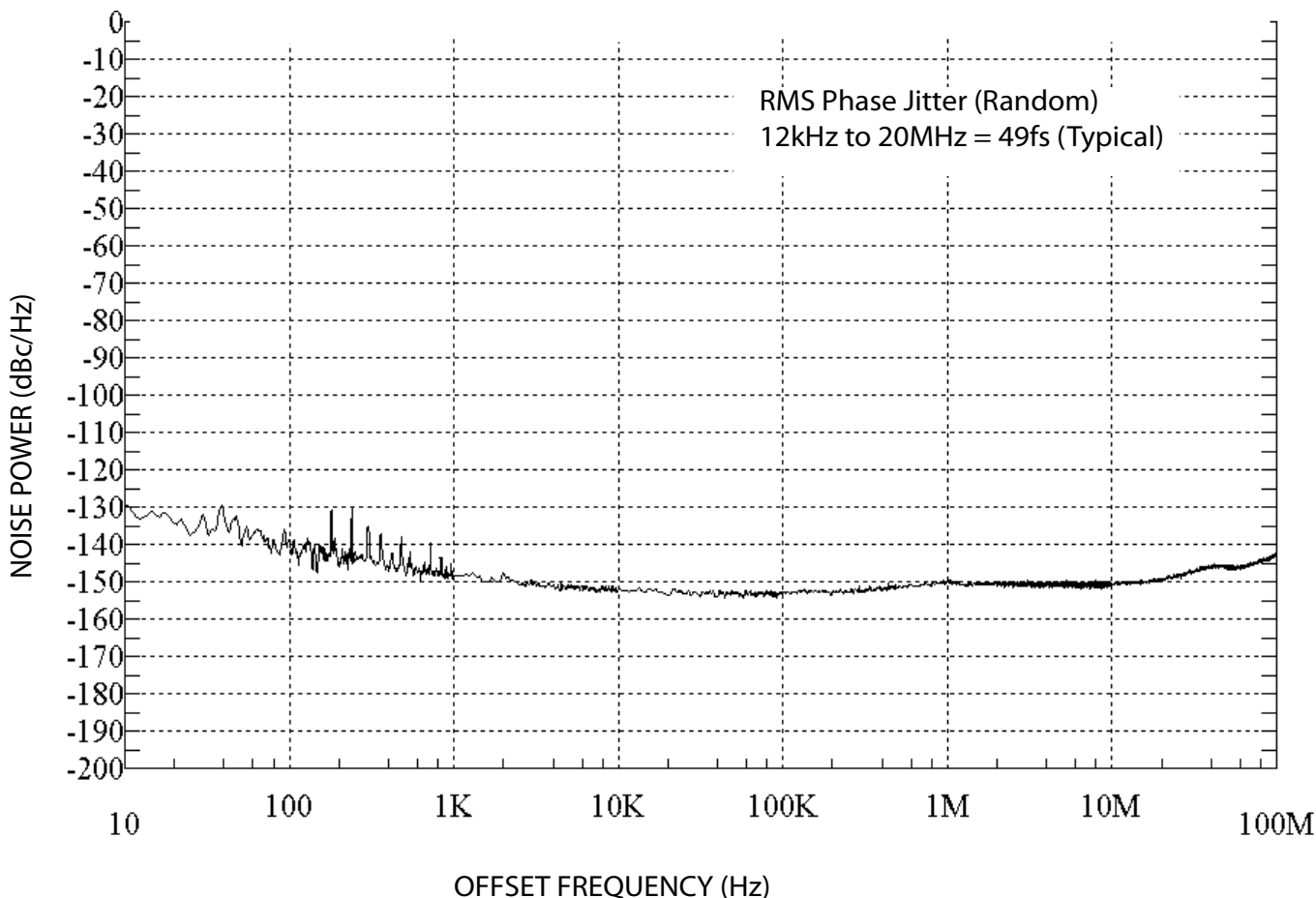

Phase Noise Plot: 622MHz @ 3.3V

TIMING DIAGRAM

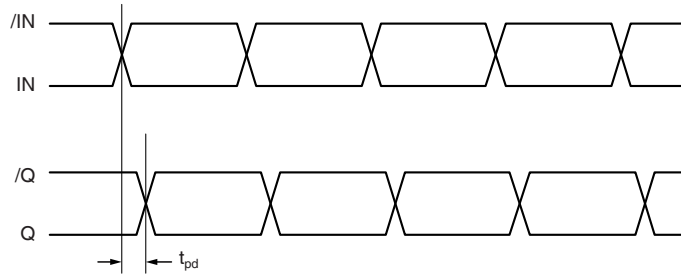

SINGLE-ENDED AND DIFFERENTIAL SWINGS

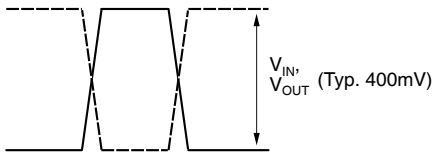

Figure 1a. Single-Ended Voltage Swing

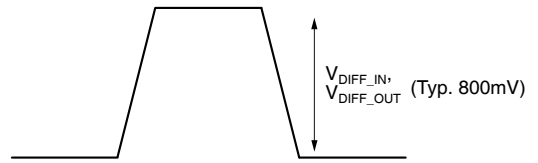
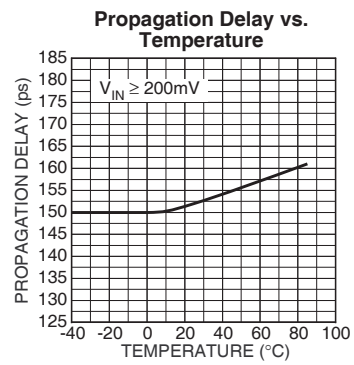
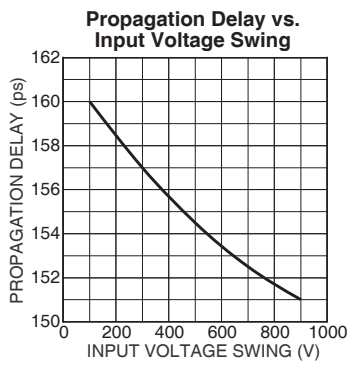
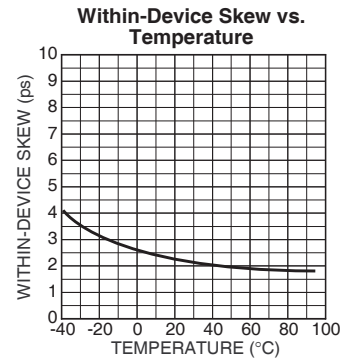
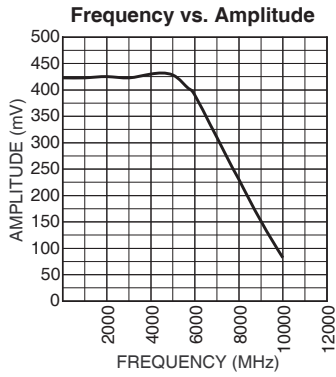

Figure 1b. Differential Voltage Swing

TYPICAL OPERATING CHARACTERISTICS

$V_{CC} = 3.3V$, $GND = 0$, $V_{IN} = 100mV$, $T_A = 25^\circ C$, unless otherwise stated.



FUNCTIONAL CHARACTERISTICS

$V_{CC} = 2.5V$, $GND = 0$, $V_{IN} = 100mV$, $T_A = 25^\circ C$, unless otherwise stated.

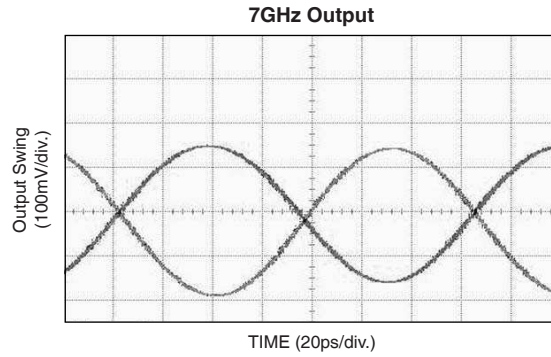
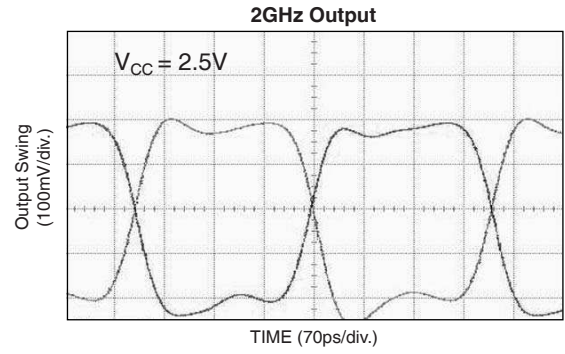
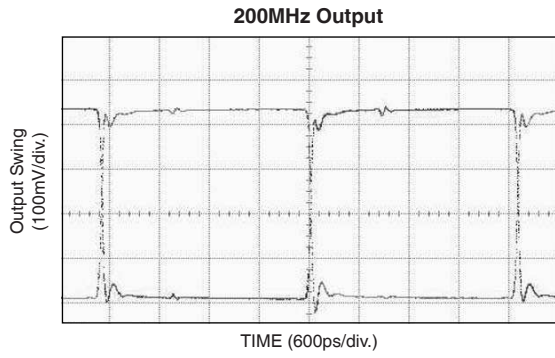

INPUT STAGE

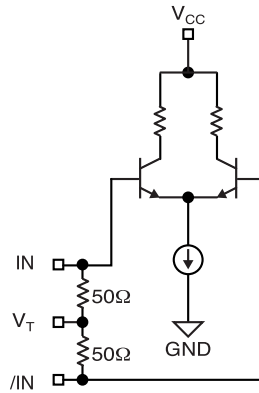

Figure 2. Simplified Differential Input Buffer

INPUT INTERFACE APPLICATIONS

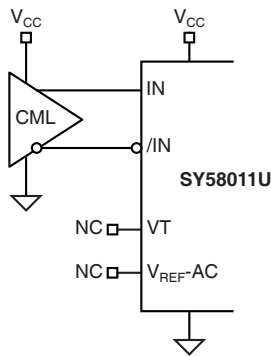

Figure 3a. DC-Coupled CML Input Interface
(option: may connect V_T to V_{CC})

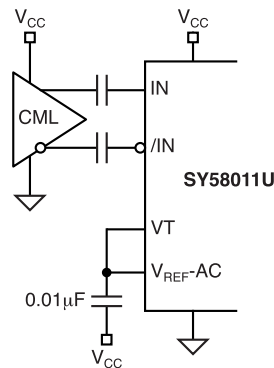
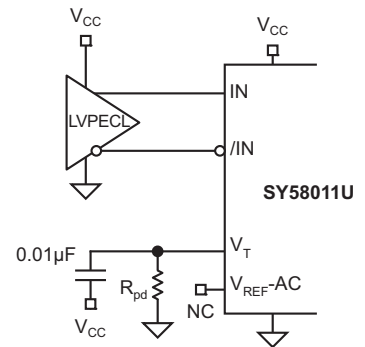
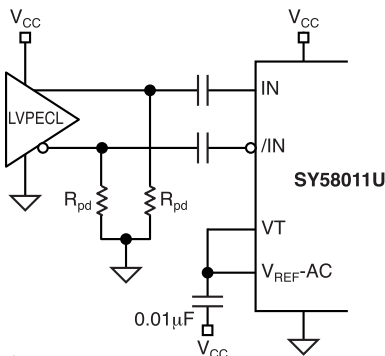

Figure 3b. AC-Coupled CML Input Interface



Note:
For $V_{CC} = 2.5V$ systems, $R_{pd} = 19\Omega$.
For $V_{CC} = 3.3V$ systems, $R_{pd} = 50\Omega$.

Figure 3c. LVPECL Input Interface



Note:
 $R_{pd} = 100\Omega$ for a 3.3V system
 $R_{pd} = 50\Omega$ for a 2.5V system

Figure 3d. AC-Coupled LVPECL Input Interface

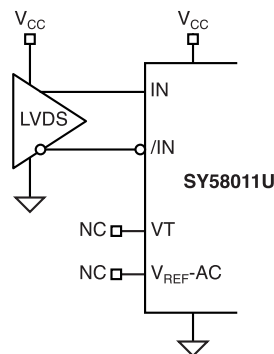

Figure 3e. LVDS Input Interface

CML OUTPUT TERMINATION

Figure 4 and Figure 5 illustrates how to terminate a CML output using both the AC-coupled and DC-coupled configuration. All outputs of the SY58011 are 50ohms with a 16mA current source.

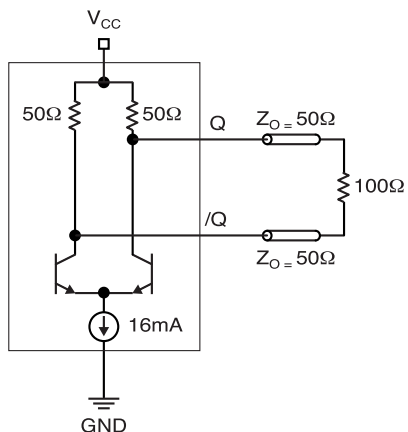

Figure 4. CML DC-Coupled Termination

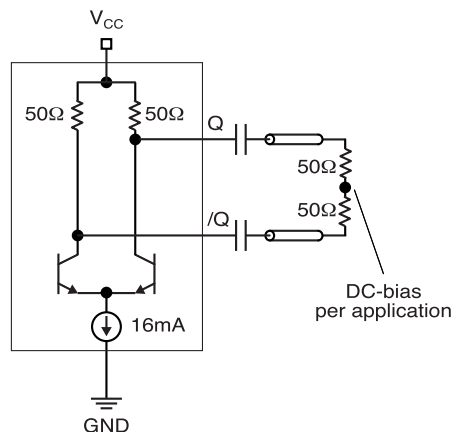
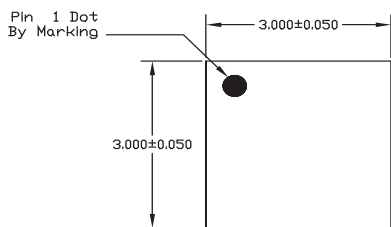

Figure 5. CML AC-Coupled Termination

RELATED MICREL PRODUCTS AND SUPPORT DOCUMENTATION

Part Number	Function	Data Sheet Link
SY58011U	7GHz, 1:2 CML Fanout Buffer/Translator with Internal I/O Termination	http://www.micrel.com/product-info/products/sy58011u.shtml
SY58012U	5GHz, 1:2 LVPECL Fanout Buffer/Translator with Internal Input Termination	http://www.micrel.com/product-info/products/sy58012u.shtml
SY58013U	6GHz, 1:2 Fanout Buffer/Translator with 400mV LVPECL Outputs and Internal Input Termination	http://www.micrel.com/product-info/products/sy58013u.shtml
	16-MLF [®] Manufacturing Guidelines Exposed Pad Application Note	www.amkor.com/products/notes_papers/MLF_AppNote_0902.pdf
	HBW Solutions	http://www.micrel.com/product-info/as/solutions.shtml

16-PIN QFN (QFN-16)



TOP VIEW

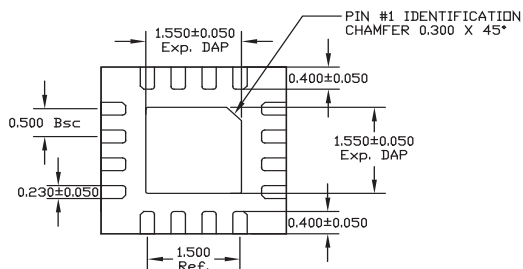

BOTTOM VIEW

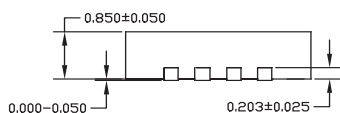

SIDE VIEW

- NOTE:
1. ALL DIMENSIONS ARE IN MILLIMETERS.
 2. MAX. PACKAGE WARPAGE IS 0.05 mm.
 3. MAXIMUM ALLOWABLE BURRS IS 0.076 mm IN ALL DIRECTIONS.
 4. PIN #1 ID ON TOP WILL BE LASER/INK MARKED.

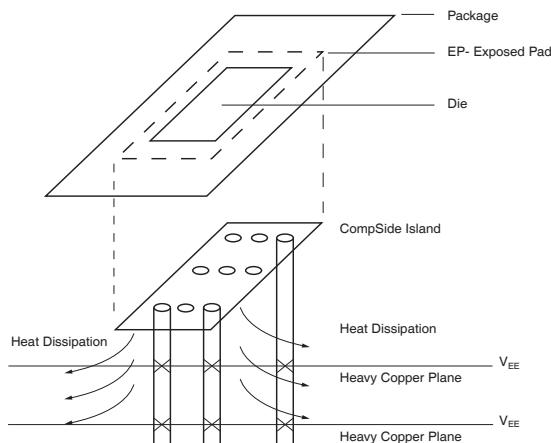

**PCB Thermal Consideration for 16-Pin QFN Package
(Always solder, or equivalent, the exposed pad to the PCB)**

Package Notes:

1. Package meets Level 2 qualification.
2. All parts are dry-packaged before shipment.
3. Exposed pads must be soldered to a ground for proper thermal management.

MICREL, INC. 2180 FORTUNE DRIVE SAN JOSE, CA 95131 USA
 TEL +1 (408) 944-0800 FAX +1 (408) 474-1000 WEB <http://www.micrel.com>

Micrel makes no representations or warranties with respect to the accuracy or completeness of the information furnished in this data sheet. This information is not intended as a warranty and Micrel does not assume responsibility for its use. Micrel reserves the right to change circuitry, specifications and descriptions at any time without notice. No license, whether express, implied, arising by estoppel or otherwise, to any intellectual property rights is granted by this document. Except as provided in Micrel's terms and conditions of sale for such products, Micrel assumes no liability whatsoever, and Micrel disclaims any express or implied warranty relating to the sale and/or use of Micrel products including liability or warranties relating to fitness for a particular purpose, merchantability, or infringement of any patent, copyright or other intellectual property right

Micrel Products are not designed or authorized for use as components in life support appliances, devices or systems where malfunction of a product can reasonably be expected to result in personal injury. Life support devices or systems are devices or systems that (a) are intended for surgical implant into the body or (b) support or sustain life, and whose failure to perform can be reasonably expected to result in a significant injury to the user. A Purchaser's use or sale of Micrel Products for use in life support appliances, devices or systems is a Purchaser's own risk and Purchaser agrees to fully indemnify Micrel for any damages resulting from such use or sale.