



## SM802123

### ClockWorks™ 125MHz/25MHz Ultra-Low Jitter, LVCMOS Frequency Synthesizer

#### General Description

The SM802123 is a member of the ClockWorks™ family of devices from Micrel and provides an extremely low-noise timing solution. It is based upon a unique patented RotaryWave® architecture that provides very-low phase noise.

The device operates from a 2.5V or 3.3V power supply and synthesizes 16 LVCMOS output clocks, eight at 125MHz and eight at 25MHz. The SM802123 accepts a 25MHz LVCMOS reference input.

Data sheets and support documentation can be found on Micrel's web site at: [www.micrel.com](http://www.micrel.com).

#### Features

- Generates eight LVCMOS output clocks at 125MHz and eight LVCMOS output clocks at 25MHz
- 2.5V or 3.3V operating range
- Typical phase jitter @ 125MHz (1.875MHz to 20MHz): 115fs
- Industrial temperature range
- Green, RoHS, and PFOS compliant
- Available in 44-pin 7mm × 7mm QFN package

#### Applications

- Gigabit Ethernet – (GbE)

#### Block Diagram Top Level Schematic

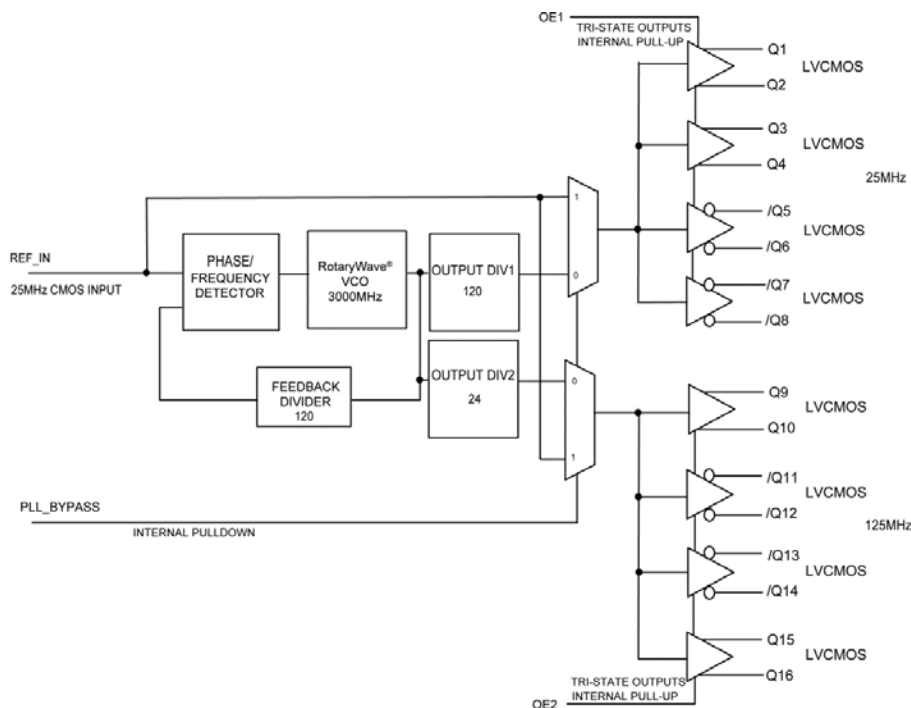

ClockWorks is a trademark of Micrel, Inc  
RotaryWave is a registered trademark of Multigig, Inc.

Micrel Inc. • 2180 Fortune Drive • San Jose, CA 95131 • USA • tel +1(408) 944-0800 • fax + 1 (408) 474-1000 • <http://www.micrel.com>

January 2012

M9999-012312-A  
[hbwhelp@micrel.com](mailto:hbwhelp@micrel.com) or (408) 955-1690

## Ordering Information

Part Number	Marking	Shipping	Junction Temperature Range <sup>(1)</sup>	Package
SM802123UMG	802123	Tray	-40°C to +85°C	44-Pin QFN
SM802123UMGTR	802123	Tape and Reel	-40°C to +85°C	44-Pin QFN

**Note:**

1. Devices are Green, RoHS, and PFOS compliant.

## Pin Configuration

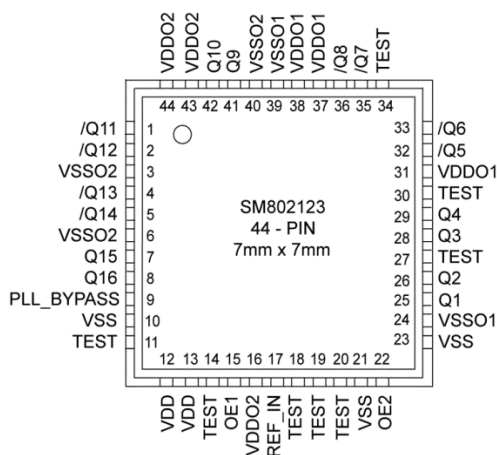

**44-Pin QFN**  
(Top View)

## Pin Description

Pin Number	Pin Name	Pin Type	Pin Level	Pin Function
25, 26 28, 29 32, 33 35, 36	Q1, Q2 Q3, Q4 /Q5, /Q6 /Q7, /Q8	O, (DIF)	LVC MOS	Clock Outputs from Bank 1 (25MHz) .
41, 42 1, 2 4, 5 7, 8	Q9, Q10 /Q11, /Q12 /Q13, /Q14 Q15, Q16	O, (DIF)	LVC MOS	Clock Outputs from Bank 2 (125MHz).
31, 37, 38	VDDO1	PWR		Power Supply for the Outputs on Bank 1 .
43, 44, 16	VDDO2	PWR		Power Supply for the Outputs on Bank 2.
24, 39	VSSO1	PWR		Power Supply Ground for the Outputs on Bank 1.
3, 6, 40	VSSO2	PWR		Power Supply Ground for the Outputs on Bank 2.
11, 14, 18, 19, 20, 27, 30, 34	TEST			Factory Test Pins. Do not connect anything to these pins.
12, 13	VDD	PWR		Core Power Supply.
10, 21, 23	VSS (Exposed Pad)	PWR		Core Power Supply Ground. The exposed pad must be connected to the VSS ground plane.

**Pin Description (Continued)**

Pin Number	Pin Name	Pin Type	Pin Level	Pin Function
17	REF_IN	I, (SE)	LVC MOS	Reference Clock Input
9	PLL_BYPASS	I, (SE)	LVC MOS	PLL Bypass, Selects Output Source 0 = Normal PLL Operation 1 = Output from Input Reference Clock 45K $\Omega$ Pull-Down
15	OE1	I, (SE)	LVC MOS	Output Enable, Q1-/Q8 disables to tri-state, 0 = Disabled, 1 = Enabled, 45K $\Omega$ Pull-Up
22	OE2	I, (SE)	LVC MOS	Output Enable, Q9-Q16 disables to tri-state, 0 = Disabled, 1 = Enabled, 45K $\Omega$ Pull-Up

**Truth Table**

OE1/2	OUTPUTS
0	Tri-State
1	LVC MOS

**Absolute Maximum Ratings<sup>(1)</sup>**

Supply Voltage ( $V_{DD}$ , $V_{DDO1/2}$ )	+4.6V
Input Voltage ( $V_{IN}$ )	-0.5V to $V_{DD}+0.5V$
Lead Temperature (soldering, 20s.)	260°C
Case Temperature	115°C
Storage Temperature ( $T_s$ )	-65°C to +150°C

**Operating Ratings<sup>(2)</sup>**

Supply Voltage ( $V_{DD}$ , $V_{DDO1/2}$ )	+2.375V to +3.465V
Ambient Temperature ( $T_A$ )	-40°C to +85°C
Junction Thermal Resistance <sup>(3)</sup>	
QFN ( $\theta_{JA}$ )	
Still-Air	24°C/W
QFN ( $\psi_{JB}$ )	
Junction-to-Board	8°C/W

**DC Electrical Characteristics<sup>(4)</sup>**

$V_{DD} = V_{DDO1/2} = 3.3V \pm 5\%$  or  $2.5V \pm 5\%$

$V_{DD} = 3.3V \pm 5\%$ ,  $V_{DDO1/2} = 3.3V \pm 5\%$  or  $2.5V \pm 5\%$

$T_A = -40^\circ\text{C}$  to  $+85^\circ\text{C}$

Symbol	Parameter	Condition	Min.	Typ.	Max.	Units
$V_{DD}$ , $V_{DDO1/2}$	3.3V Operating Voltage	$V_{DDO1} = V_{DDO2}$	3.135	3.3	3.465	V
	2.5V Operating Voltage	$V_{DDO1} = V_{DDO2}$	2.375	2.5	2.625	V
$I_{DD}$	Total supply current	Outputs floating		130	170	mA

**LVC MOS INPUT (OE1, OE2, PLL\_BYPASS) DC Electrical Characteristics<sup>(4)</sup>**

$V_{DD} = 3.3V \pm 5\%$ , or  $2.5V \pm 5\%$ ,  $T_A = -40^\circ\text{C}$  to  $+85^\circ\text{C}$

Symbol	Parameter	Condition	Min.	Typ.	Max.	Units
$V_{IH}$	Input High Voltage		2		$V_{DD} + 0.3$	V
$V_{IN}$	Input Low Voltage		-0.3		0.8	V
$I_{IH}$	Input High Current	$V_{DD} = V_{IN} = 3.465V$			150	$\mu\text{A}$
$I_{IL}$	Input Low Current	$V_{DD} = 3.465V$ , $V_{IN} = 0V$	-150			$\mu\text{A}$

**LVC MOS OUTPUT DC Electrical Characteristics<sup>(4)</sup>**

$V_{DD} = V_{DDO1/2} = 3.3V \pm 5\%$  or  $2.5V \pm 5\%$

$V_{DD} = 3.3V \pm 5\%$ ,  $V_{DDO1/2} = 3.3V \pm 5\%$  or  $2.5V \pm 5\%$

$T_A = -40^\circ\text{C}$  to  $+85^\circ\text{C}$ .  $R_L = 50\Omega$  to  $V_{DDO}/2$

Symbol	Parameter	Condition	Min.	Typ.	Max.	Units
$V_{OH}$	Output High Voltage	Figure 4	$V_{DDO} - 0.7$			V
$V_{OL}$	Output Low Voltage	Figure 4			0.6	V

**Notes:**

- Permanent device damage may occur if absolute maximum ratings are exceeded. This is a stress rating only and functional operation is not implied at conditions other than those detailed in the operational sections of this data sheet. Exposure to absolute maximum rating conditions for extended periods may affect device reliability.
- The data sheet limits are not guaranteed if the device is operated beyond the operating ratings.
- Package thermal resistance assumes exposed pad is soldered (or equivalent) to the devices most negative potential on the PCB.
- The circuit is designed to meet the AC and DC specifications shown in the above table after thermal equilibrium has been established.

## REF\_IN DC Electrical Characteristics<sup>(4)</sup>

$V_{DD} = 3.3V \pm 5\%$ , or  $2.5V \pm 5\%$ ,  $T_A = -40^\circ C$  to  $+85^\circ C$

Symbol	Parameter	Condition	Min.	Typ.	Max.	Units
$V_{IH}$	Input High Voltage		1.1		$V_{DD} + 0.3$	V
$V_{IL}$	Input Low Voltage		-0.3		0.6	V
$I_{IN}$	Input Current	$V_{IN} = 0V$ to $V_{DD}$	-5		5	$\mu A$

## AC Electrical Characteristics<sup>(4, 5)</sup>

$V_{DD} = V_{DDO1/2} = 3.3V \pm 5\%$  or  $2.5V \pm 5\%$

$V_{DD} = 3.3V \pm 5\%$ ,  $V_{DDO1/2} = 3.3V \pm 5\%$  or  $2.5V \pm 5\%$

$T_A = -40^\circ C$  to  $+85^\circ C$ .  $R_L = 50\Omega$  to  $V_{DDO}/2$

Symbol	Parameter	Condition	Min	Typ	Max	Units
$F_{OUT}$	Output Frequency	Q1 – /Q8		25		MHz
		Q9 – Q16		125		
$T_R/T_F$	LVC MOS Output Rise/Fall Time	20% – 80%, Fig. 2	100	200	500	ps
ODC	Output Duty Cycle		45	50	55	%
$T_{LOCK}$	PLL Lock Time				20	ms
$T_{jit}(\emptyset)$	RMS Phase Jitter <sup>(6)</sup> (Output = 25MHz)	Integration Range:(12kHz – 5MHz) 5MHz limited by phase-noise system.		315		fs
		Integration Range:(12kHz – 20MHz)		340		fs
	RMS Phase Jitter <sup>(6)</sup> (Output = 125MHz)	Integration Range:(1.875MHz – 20MHz)		115		fs
	Spurious Noise Components	25MHz		-64		dBc

### Notes:

- All phase-noise measurements were taken with an Agilent 5052B phase-noise system.
- REF\_IN driven with a low-noise source ClockWorks™ SM802001 programmed for a 25MHz CMOS output. Phase noise will track the input phase noise up to about 1MHz offset frequency.

# Phase Noise Plots

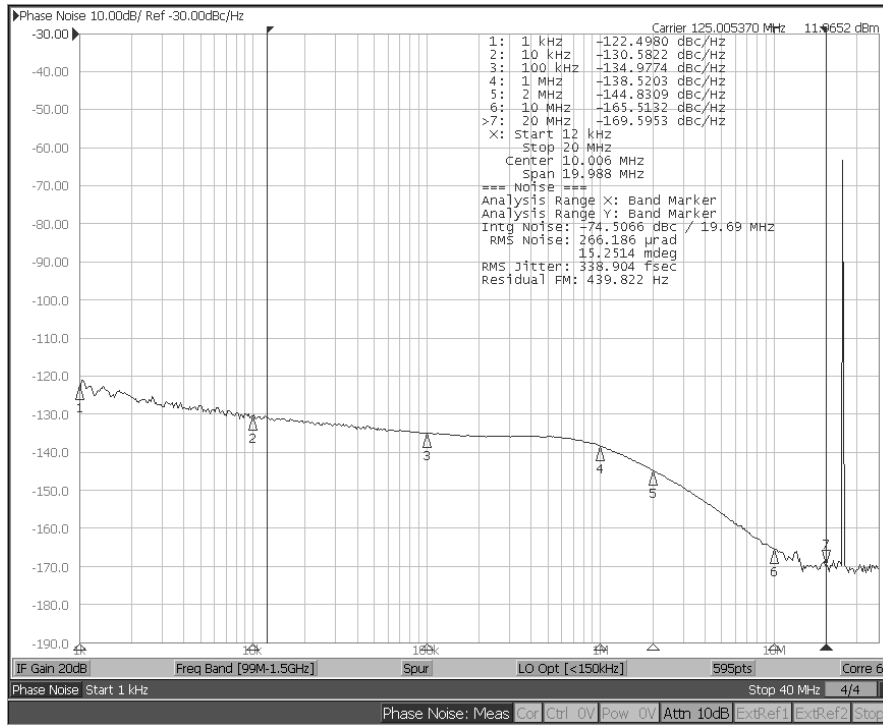

**125MHz LVCMOS Integrated Jitter 12kHz – 20MHz 339fs**

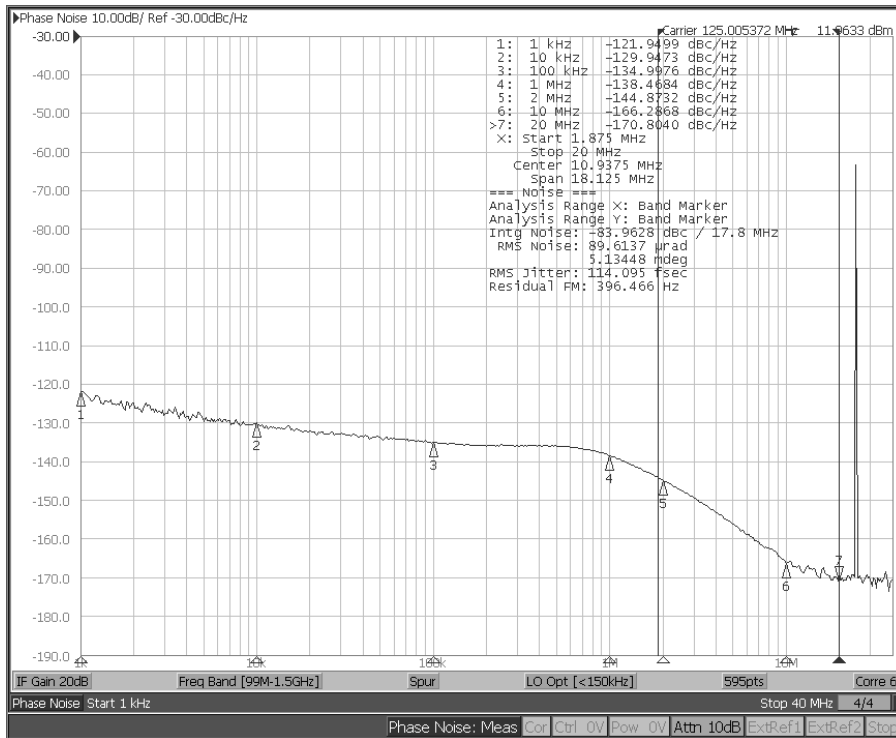

**125MHz LVCMOS Integrated Jitter 1.875MHz – 20MHz 114fs**

### Phase Noise Plots (Continued)

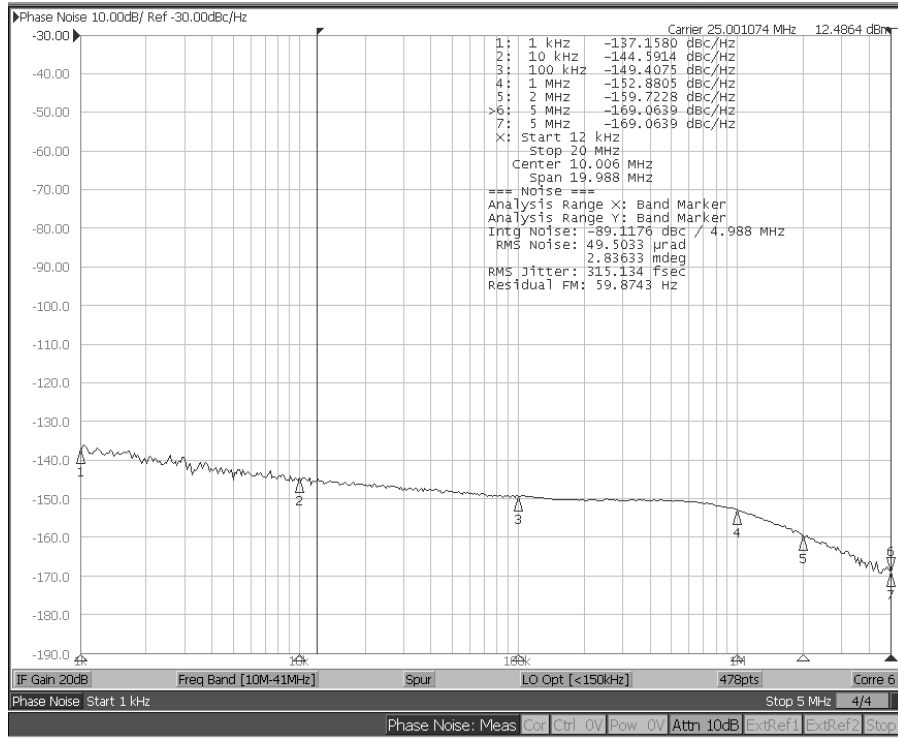

**25MHz LVC MOS Integrated Jitter 12kHz – 5MHz 315fs**

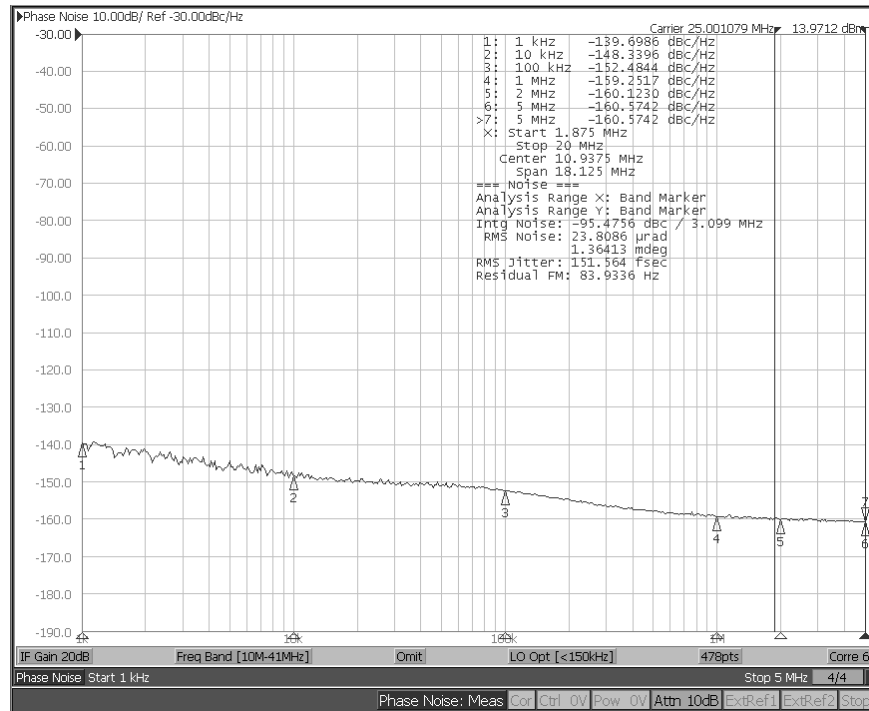

**Input Source (25MHz LVC MOS) Programmed from a Clockworks™ Part**

### Phase Noise Plots (Continued)

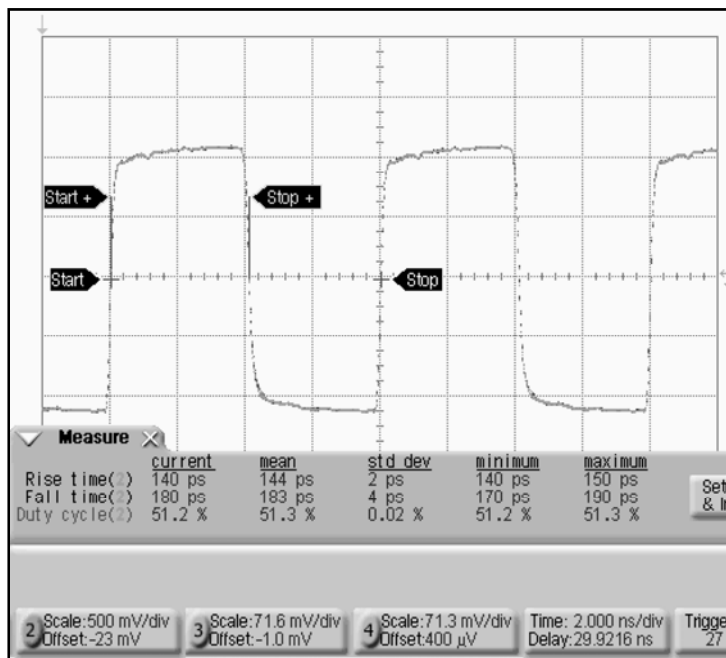

125MHz LVCMOS Output Waveform

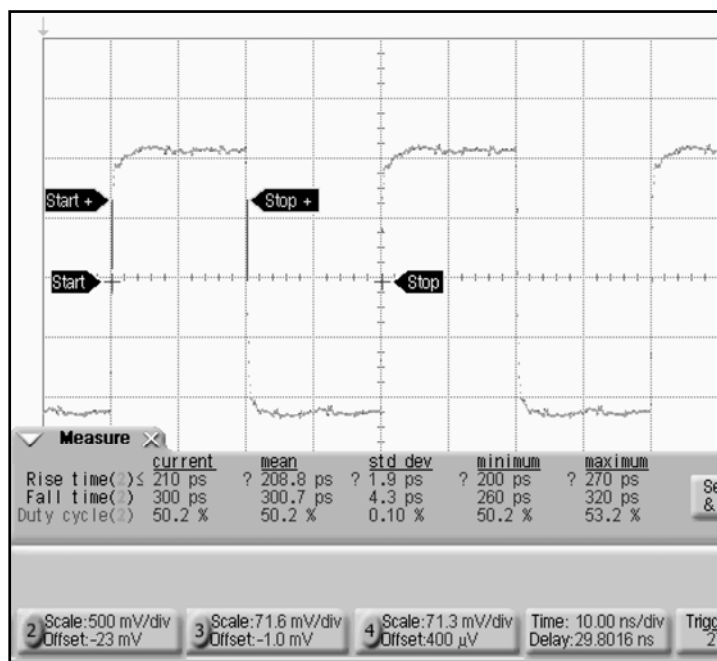

25MHz LVCMOS Output Waveform

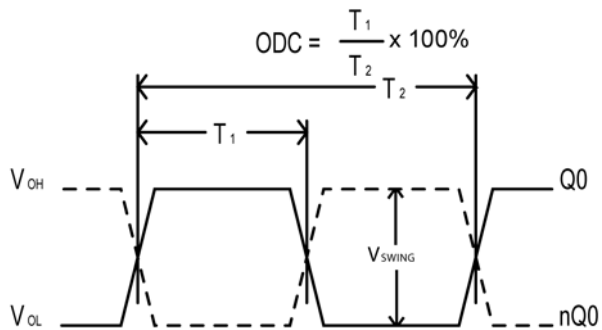

Figure 1. Duty Cycle Timing

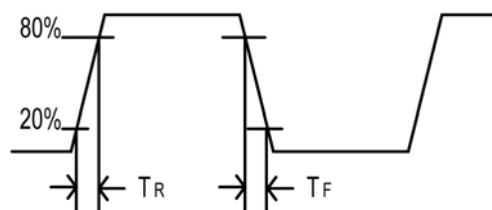

Figure 2. All Outputs Rise/Fall Time

RMS Phase Noise/Jitter

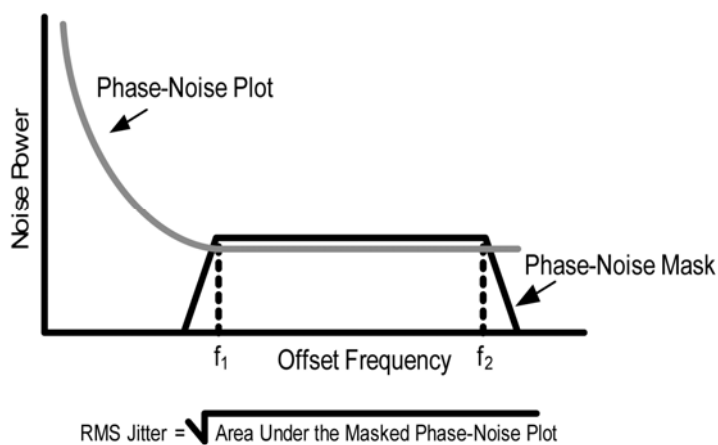

Figure 3. RMS Phase Noise/Jitter

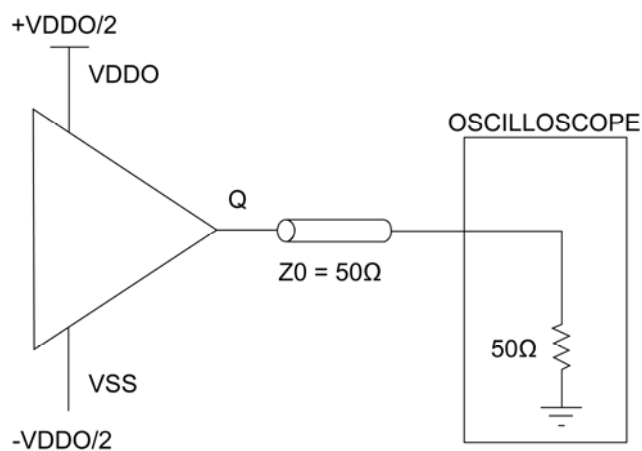

Figure 4. LVC MOS Output Load and Test Circuit



**Revision Template History**

<b>Date</b>	<b>Change Description/Edits by:</b>	<b>Rev.</b>
8/4/10	Added new paragraph to disclaimer in boiler plate. Per Colin Sturt. M.Galvan	14

# HBW Datasheet Revision History

Part Number:

Initial Release Date:

Rev.	Date	Revisions	Reason	Engineer
A				