



SM802109

ClockWorks™ PCI-e Quad 100MHz Ultra-Low Jitter, HCSL Frequency Synthesizer

General Description

The SM802109 is a member of the ClockWorks™ family of devices from Micrel and provides an extremely low-noise timing solution for PCI-Express clock signals. It is based on a unique patented RotaryWave® architecture that provides very-low phase noise.

The device operates from a 3.3V or 2.5V power supply and synthesizes four HCSL output clocks at 100MHz. The SM802109 accepts a 25MHz crystal or LVCMOS reference clock.

Data sheets and support documentation can be found on Micrel's web site at: www.micrel.com.

Features

- Generates four HCSL clock outputs at 100MHz
- 2.5V or 3.3V operating range
- Typical phase jitter @ 100MHz (1.875MHz to 20MHz): 105fs
- Industrial temperature range (-40°C to +85°C)
- Green, RoHS, and PFOS compliant
- Available in 24-pin 4mm × 4mm QFN package

Applications

- PCI-Express

Block Diagram

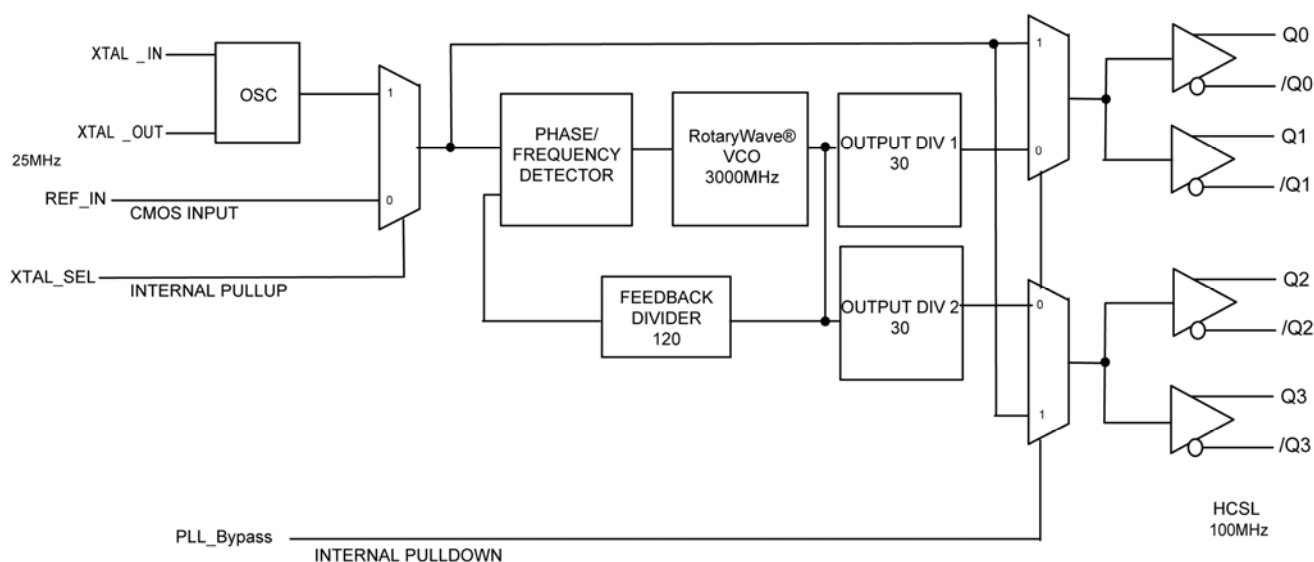

ClockWorks is a trademark of Micrel, Inc
RotaryWave is a registered trademark of Multigig, Inc.

Micrel Inc. • 2180 Fortune Drive • San Jose, CA 95131 • USA • tel +1(408) 944-0800 • fax +1 (408) 474-1000 • <http://www.micrel.com>

September 2011

M9999-092911-B
hbwhelp@micrel.com or (408) 955-1690

Ordering Information⁽¹⁾

Part Number	Marking	Shipping	Temperature Range	Package
SM802109UMG	802109	Tube	-40°C to +85°C	24-Pin QFN
SM802109UMGTR	802109	Tape and Reel	-40°C to +85°C	24-Pin QFN

Note:

1. Devices are Green, RoHS, and PFOS compliant.

Pin Configuration

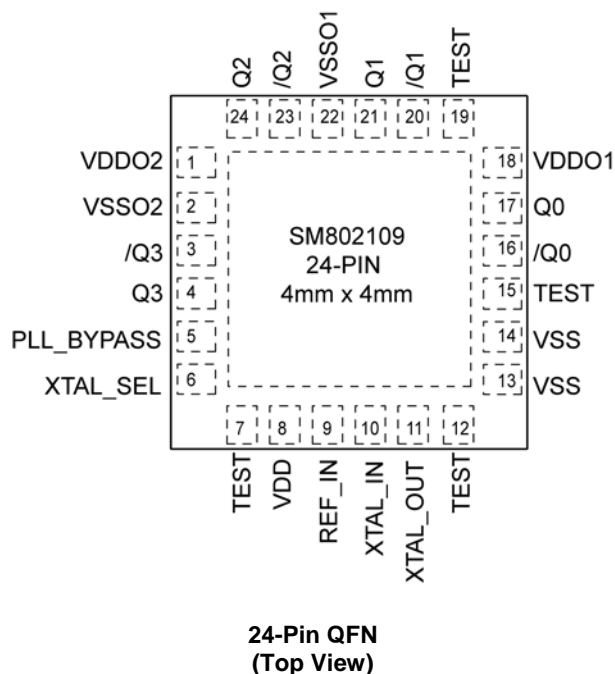

Pin Description

Pin Number	Pin Name	Pin Type	Pin Level	Pin Function
16, 17 20, 21	/Q0, Q0 /Q1, Q1	O, (DIF)	HCSL	Differential Clock Outputs from Bank 1 100MHz
23, 24 3, 4	/Q2, Q2 /Q3, Q3	O, (DIF)	HCSL	Differential Clock Outputs from Bank 2 100MHz
1	VDDO2	PWR		Power Supply for Output Bank 2
2	VSSO2	PWR		Power Supply Ground for Output Bank 2
5	PLL_BYPASS	I, (SE)	LVC MOS	PLL Bypass, Selects Output Source 0 = Normal PLL Operation 1 = Output from Input Reference Clock or Crystal 45KΩ pulldown
6	XTAL_SEL	I, (SE)	LVC MOS	Selects PLL Input Reference Source 0 = REF_IN, 1 = XTAL, 45KΩ pullup

Pin Description (Continued)

Pin Number	Pin Name	Pin Type	Pin Level	Pin Function
7, 12, 15, 19	TEST			Factory Test pins, Do not connect anything to these pins.
8	VDD	PWR		Core Power Supply
13, 14	VSS (Exposed Pad)	PWR		Core Power Supply Ground. The exposed pad must be connected to the VSS ground plane.
18	VDDO1	PWR		Power Supply for Output Bank 1
22	VSSO1	PWR		Power Supply Ground for Output Bank 1
9	REF_IN	I, (SE)	LVC MOS	Reference Clock Input
10	XTAL_IN	I, (SE)	Crystal	Crystal Reference Input, no load caps needed (see Figure 5).
11	XTAL_OUT	O, (SE)	Crystal	Crystal Reference Output, no load caps needed (see Figure 5).

Truth Table

PLL_BYPASS	XTAL_SEL	INPUT	OUTPUT
0	–	–	PLL
1	–	–	XTAL/REF_IN
–	0	REF_IN	–
–	1	XTAL	–

Absolute Maximum Ratings⁽¹⁾

Supply Voltage (V_{DD} , $V_{DDO1/2}$)	+4.6V
Input Voltage (V_{IN})	-0.50V to $V_{DD} + 0.5V$
Lead Temperature (soldering, 20s)	260°C
Case Temperature	115°C
Storage Temperature (T_s)	-65°C to +150°C

Operating Ratings⁽²⁾

Supply Voltage (V_{DD} , $V_{DDO1/2}$)	+2.375V to +3.465V
Ambient Temperature (T_A)	-40°C to +85°C
Junction Thermal Resistance ⁽³⁾	
QFN (θ_{JA})	
Still-Air	50°C/W
QFN (ψ_{JB})	
Junction-to-Board	30°C/W

DC Electrical Characteristics⁽⁴⁾

$V_{DD} = V_{DDO1/2} = 3.3V \pm 5\%$ or $2.5V \pm 5\%$
 $V_{DD} = 3.3V \pm 5\%$, $V_{DDO1/2} = 3.3V \pm 5\%$ or $2.5V \pm 5\%$
 $T_A = -40^\circ C$ to $+85^\circ C$.

Symbol	Parameter	Condition	Min.	Typ.	Max.	Units
V_{DD} , $V_{DDO1/2}$	2.5V Operating Voltage		2.375	2.5	2.625	V
V_{DD} , $V_{DDO1/2}$	3.3V Operating Voltage		3.135	3.3	3.465	V
I_{DD} REF_IN	Supply current $V_{DD} + V_{DDO}$	XTAL_SEL = 0 Outputs 50Ω to V_{SS}		140	175	mA
I_{DD} XTAL	Supply current $V_{DD} + V_{DDO}$	XTAL_SEL = 1 Outputs 50Ω to V_{SS}		150	185	mA

HCSL DC Electrical Characteristics⁽⁴⁾

$V_{DD} = V_{DDO1/2} = 3.3V \pm 5\%$ or $2.5V \pm 5\%$
 $V_{DD} = 3.3V \pm 5\%$, $V_{DDO1/2} = 3.3V \pm 5\%$ or $2.5V \pm 5\%$
 $T_A = -40^\circ C$ to $+85^\circ C$. $R_L = 50\Omega$ to V_{SS}

Symbol	Parameter	Condition	Min	Typ.	Max.	Units
V_{OH}	Output High Voltage		660	700	850	mV
V_{OL}	Output Low Voltage		-150	0	27	mV
V_{CROSS}	Crossing Point Voltage		250	350	550	mV

Notes:

1. Permanent device damage may occur if absolute maximum ratings are exceeded. This is a stress rating only and functional operation is not implied at conditions other than those detailed in the operational sections of this data sheet. Exposure to absolute maximum rating conditions for extended periods may affect device reliability.
2. The data sheet limits are not guaranteed if the device is operated beyond the operating ratings.
3. Package thermal resistance assumes exposed pad is soldered (or equivalent) to the devices most negative potential on the PCB.
4. The circuit is designed to meet the AC and DC specifications shown in the above table(s) after thermal equilibrium has been established.

LVC MOS (PLL_BYPASS, XTAL_SEL) DC Electrical Characteristics⁽⁴⁾

$V_{DD} = 3.3V \pm 5\%$, or $2.5V \pm 5\%$, $T_A = -40^\circ C$ to $+85^\circ C$.

Symbol	Parameter	Condition	Min.	Typ.	Max.	Units
V_{IH}	Input High Voltage		2		$V_{DD} + 0.3$	V
V_{IL}	Input Low Voltage		-0.3		0.8	V
I_{IH}	Input High Current	$V_{DD} = V_{IN} = 3.465V$			150	μA
I_{IL}	Input Low Current	$V_{DD} = 3.465V, V_{IN} = 0V$	-150			μA

REF_IN DC Electrical Characteristics⁽⁴⁾

$V_{DD} = 3.3V \pm 5\%$, or $2.5V \pm 5\%$, $T_A = -40^\circ C$ to $+85^\circ C$.

Symbol	Parameter	Condition	Min.	Typ.	Max.	Units
V_{IH}	Input High Voltage		1.1		$V_{DD} + 0.3$	V
V_{IL}	Input Low Voltage		-0.3		0.6	V
I_{IN}	Input Current	$XTAL_SEL = V_{IL}, V_{IN} = 0V$ to V_{DD}	-5		5	μA
		$XTAL_SEL = V_{IH}, V_{IN} = V_{DD}$		20		μA

Crystal Characteristics

Parameter	Condition	Min.	Typ.	Max.	Units
Mode of Oscillation	10pF to 12pF Load	Fundamental, Parallel Resonant			
Frequency			25		MHz
Equivalent Series Resistance (ESR)				50	Ω
Shunt Capacitor, C0			1	5	pF
Correlation Drive Level			10	100	μW

AC Electrical Characteristics^(4, 5)
 $V_{DD} = V_{DDO1/2} = 3.3V \pm 5\%$ or $2.5V \pm 5\%$
 $V_{DD} = 3.3V \pm 5\%$, $V_{DDO1/2} = 3.3V \pm 5\%$ or $2.5V \pm 5\%$
 $T_A = -40^\circ\text{C}$ to $+85^\circ\text{C}$. $R_L = 50\Omega$ to V_{SS}

Symbol	Parameter	Condition	Min.	Typ.	Max.	Units
F_{OUT}	Output Frequency			100		MHz
F_{REF}	Reference Input Frequency			25		MHz
T_R/T_F	LVPECL Output Rise/Fall Time	20% – 80%	150	300	450	ps
ODC	Output Duty Cycle		48	50	52	%
T_{SKEW}	Output-to-Output Skew	Note 6			45	ps
T_{LOCK}	PLL Lock Time				20	ms
$T_{jit}(\emptyset)$	RMS Phase Jitter ⁽⁷⁾	100MHz Integration Range (1.875MHz – 20MHz) Integration Range (12kHz – 20MHz)		105 250		fs
	Spurious Noise Components	25MHz		-95		dBc

Notes:

- All phase noise measurements were taken with an Agilent 5052B phase noise system.
- Defined as skew between outputs at the same supply voltage and with equal load conditions; measured at the output differential crossing points.
- Measured using 25MHz crystal as the input reference source. If using an external reference input, use a low phase noise source. With an external reference, the phase noise will follow the input source phase noise up to about 1MHz.

Application Information

Input Reference

When operating with a crystal input reference, do not apply a switching signal to REF_IN.

Crystal Layout

Keep the layers under the crystal as open as possible and do not place switching signals or noisy supplies under the crystal.

Crystal load capacitance is built inside the die so no external capacitance is needed. See the *Selecting a Quartz crystal for the Clockworks Flex I Family of Precision Synthesizers* application note for further details.

Contact Micrel's HBW applications group if you need assistance on selecting a suitable crystal for your application at: hbwhelp@micrel.com.

HCSL Outputs

HCSL outputs are to be terminated with 50Ω to V_{SS} . For best performance load all outputs. If you want to AC-couple or change the termination, contact Micrel's application group: hbwhelp@micrel.com.

Phase Noise Plots

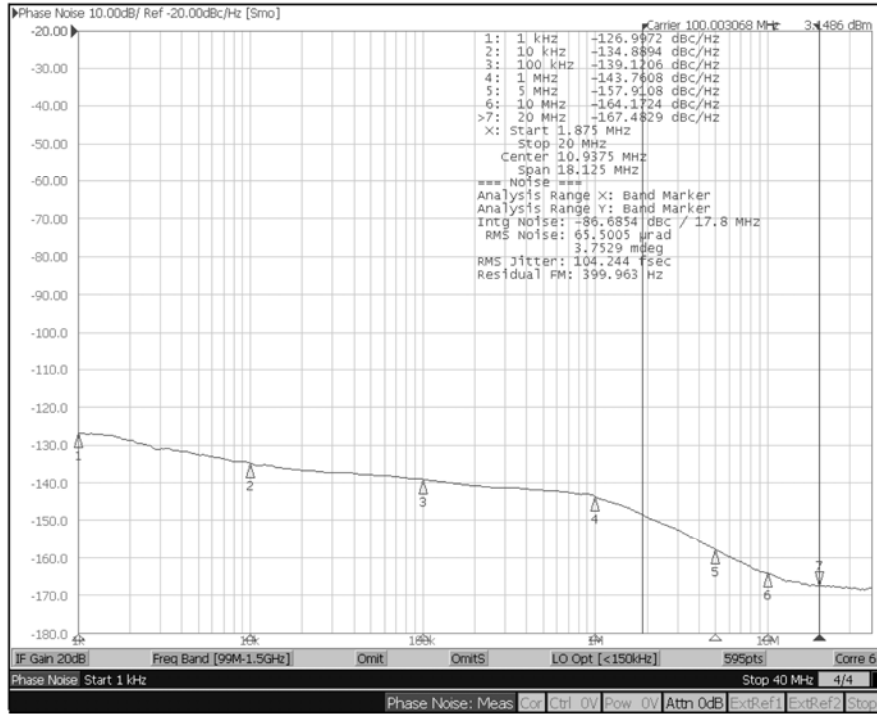

Phase Noise Plot: 100MHz, 1.875MHz – 20MHz 104fS

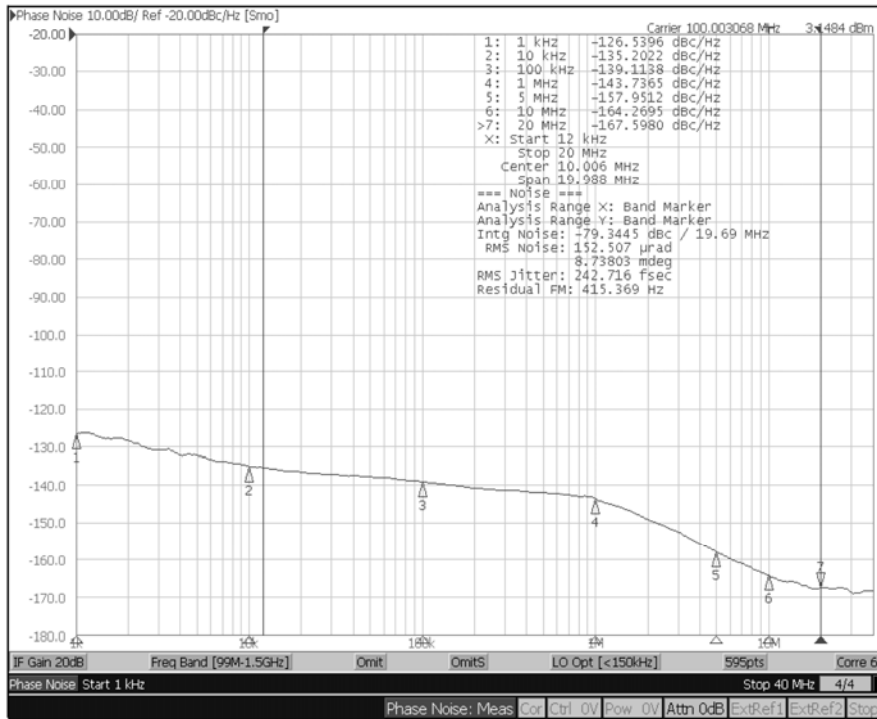

Phase Noise Plot: 100MHz, 12kHz – 20MHz 242fS

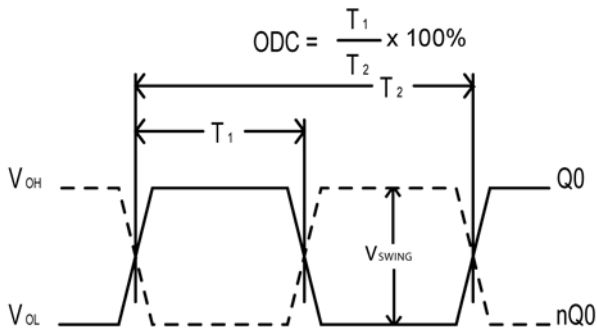

Figure 1. Duty Cycle Timing

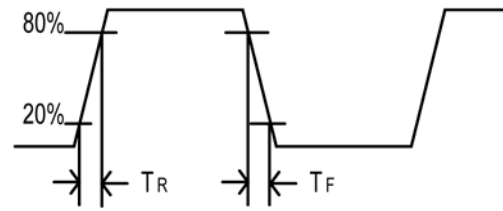

Figure 2. All Outputs Rise/Fall Time

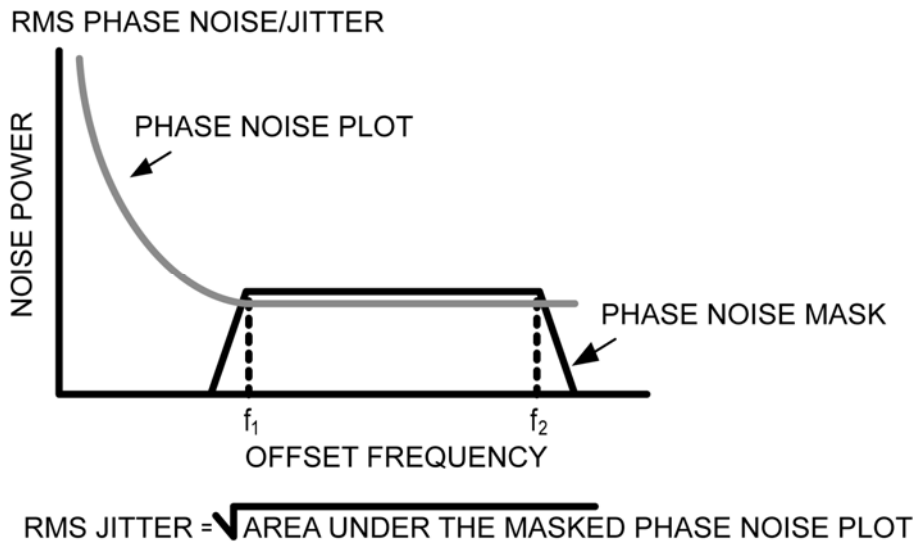

Figure 3. RMS Phase/Noise Jitter

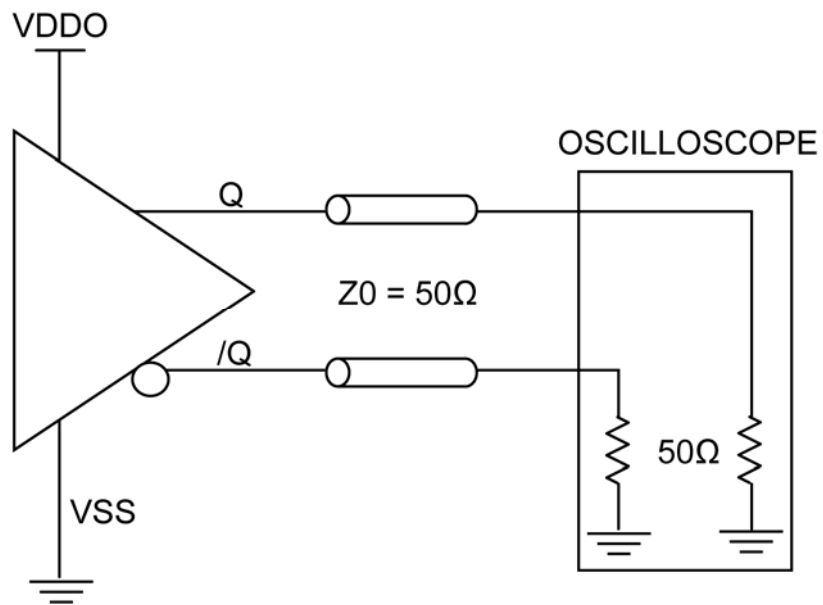

Figure 4. HCSL Output Load and Test Circuit

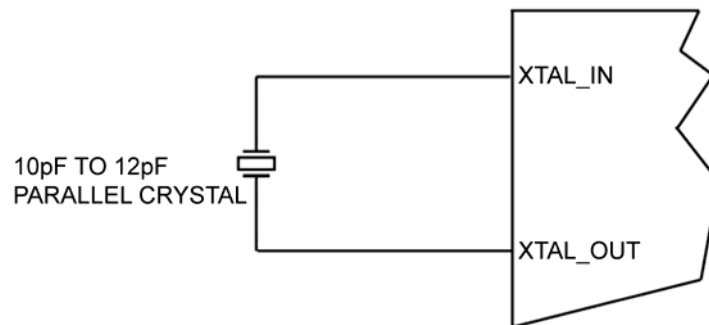
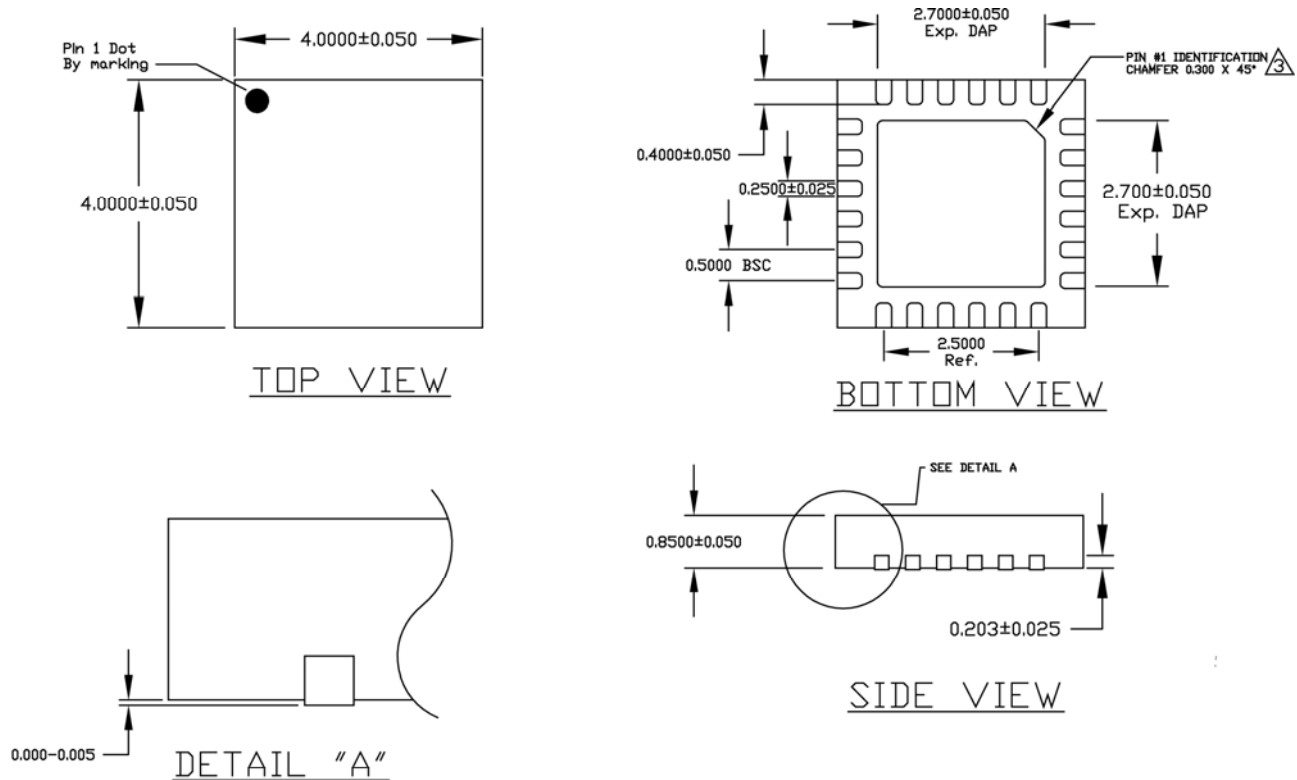

Figure 5. Crystal Input Interface

Package Information



NOTE:

1. ALL DIMENSIONS ARE IN MILLIMETERS (mm).
2. THE PIN#1 IDENTIFIER MUST EXIST ON THE TOP SURFACE OF PACKAGE BY USING IDENTIFICATION MARK OR OTHER FEATURE OF PACKAGE BODY.

CHAMFER STYLE PIN 1 IDENTIFIER ON BOTTOM SIDE

24-Pin Package Type

MICREL, INC. 2180 FORTUNE DRIVE SAN JOSE, CA 95131 USA
 TEL +1 (408) 944-0800 FAX +1 (408) 474-1000 WEB <http://www.micrel.com>

Micrel makes no representations or warranties with respect to the accuracy or completeness of the information furnished in this data sheet. This information is not intended as a warranty and Micrel does not assume responsibility for its use. Micrel reserves the right to change circuitry, specifications and descriptions at any time without notice. No license, whether express, implied, arising by estoppel or otherwise, to any intellectual property rights is granted by this document. Except as provided in Micrel's terms and conditions of sale for such products, Micrel assumes no liability whatsoever, and Micrel disclaims any express or implied warranty relating to the sale and/or use of Micrel products including liability or warranties relating to fitness for a particular purpose, merchantability, or infringement of any patent, copyright or other intellectual property right.

Micrel Products are not designed or authorized for use as components in life support appliances, devices or systems where malfunction of a product can reasonably be expected to result in personal injury. Life support devices or systems are devices or systems that (a) are intended for surgical implant into the body or (b) support or sustain life, and whose failure to perform can be reasonably expected to result in a significant injury to the user. A Purchaser's use or sale of Micrel Products for use in life support appliances, devices or systems is a Purchaser's own risk and Purchaser agrees to fully indemnify Micrel for any damages resulting from such use or sale.

© 2011 Micrel, Incorporated.