



SM802110

ClockWorks™ CPRI 153.6MHz
Ultra-Low Jitter, LVPECL
Frequency Synthesizer

General Description

The SM802110 is a member of the ClockWorks™ family of devices from Micrel and provides an extremely low-noise timing solution for CPRI clock signals. It is based upon a unique patented RotaryWave® architecture that provides very low phase noise.

The device operates from a 3.3V or 2.5V power supply and synthesizes an LVPECL output clock at 153.6MHz. The SM802110 accepts a 30.72MHz LVCMOS reference clock.

Data sheets and support documentation can be found on Micrel's web site at www.micrel.com.

Features

- Generates an LVPECL clock outputs at 153.6MHz
- 2.5V or 3.3V operating range
- Typical phase jitter @ 153.6MHz (2MHz to 20MHz): 99fs (typical) at 3.3V
- Industrial temperature range
- Green, RoHS, and PFOS compliant
- Available in 24-pin 4x4mm QFN

Applications

- CPRI
- OBSAI

Block Diagram

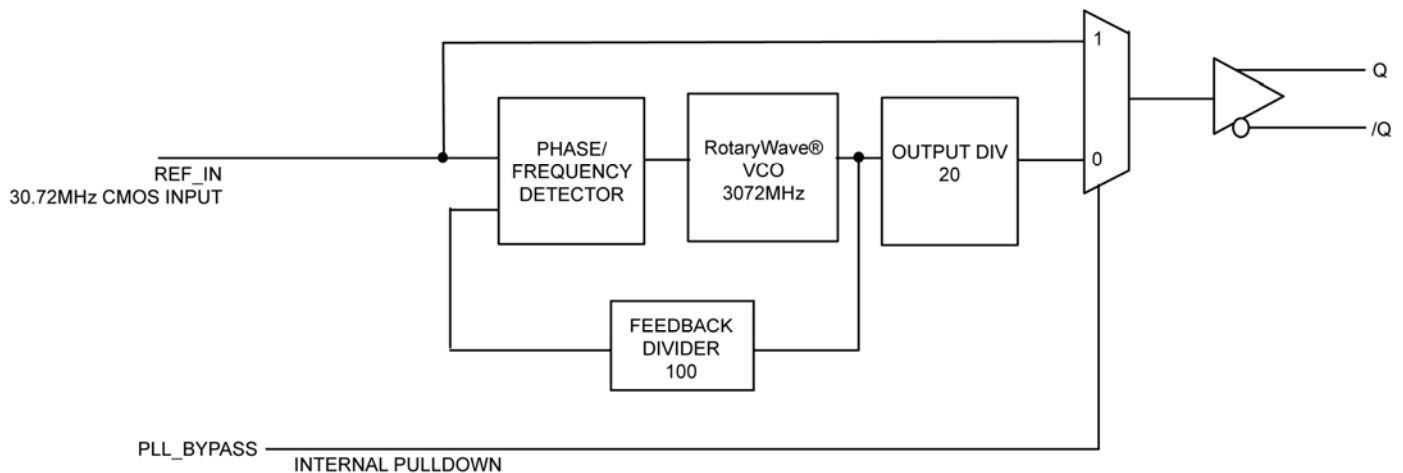

ClockWorks is a trademark of Micrel, Inc.
RotaryWave is a registered trademark of Multigig, Inc.

Micrel Inc. • 2180 Fortune Drive • San Jose, CA 95131 • USA • tel +1 (408) 944-0800 • fax +1 (408) 474-1000 • <http://www.micrel.com>

January 2011

M9999-012111-A
hbwhelp@micrel.com or (408) 955-1690

Ordering Information

Part Number	Marking	Shipping	Junction Temperature Range ⁽¹⁾	Package
SM802110UMG	802110	Tube	-40°C to +85°C	24-Pin QFN
SM802110UMGR	802110	Tape & Reel	-40°C to +85°C	24-Pin QFN

Note:

1. Devices are Green, RoHS, and PFOS compliant.

Pin Configuration

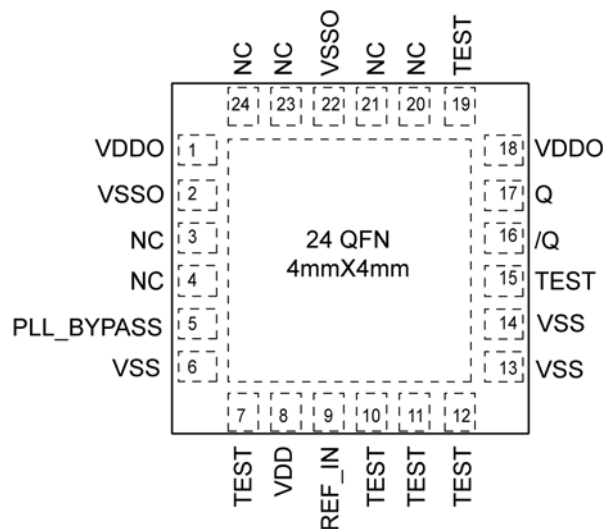

**24-Pin QFN
(Top View)**

Pin Description

Pin Number	Pin Name	Pin Type	Pin Level	Pin Function
16, 17	/Q, Q	O, (DIF)	LVPECL	Differential Clock Output
1, 18	VDDO	PWR		Power Supply for Clock Output
2, 22	VSSO	PWR		Power Supply Grounds for Clock Output
3, 4, 20, 21, 23, 24	NC			No Connect, Do not connect anything to these pins.
5	PLL_BYPASS	I, (SE)	LVC MOS	PLL Bypass, Selects Output Source 0 = Normal PLL Operation 1 = Output from Input Reference Clock 45KΩ pull-down
7, 10, 11, 12, 15, 19	TEST			Factory Test Pins. Do not connect anything to these pins.
8	VDD	PWR		Core Power Supply
9	REF_IN	I, (SE)	LVC MOS	Reference Clock Input
6, 13, 14	VSS	PWR		Core Power Supply Ground.

Absolute Maximum Ratings⁽¹⁾

Supply Voltage (V_{DD}, V_{DDO})	+4.6V
Input Voltage (V_{IN})	-0.50V to $V_{DD} + 0.5V$
Lead Temperature (soldering, 20sec.)	260°C
Case Temperature	115°C
Storage Temperature	-65°C to +150°C

Operating Ratings⁽²⁾

Supply Voltage (V_{DD}, V_{DDO})	+2.375V to +3.465V
Ambient Temperature (T_A)	-40°C to +85°C
Junction Thermal Resistance ⁽³⁾	
QFN (θ_{JA})	
Still-Air	50°C/W
QFN (ψ_{JA})	
Junction-to-Board	30°C/W

DC Electrical Characteristics⁽⁴⁾

$V_{DD} = V_{DDO} = 3.3V \pm 5\%$ or $2.5V \pm 5\%$

$V_{DD} = 3.3V \pm 5\%$, $V_{DDO} = 3.3V \pm 5\%$ or $2.5V \pm 5\%$

$T_A = -40^\circ\text{C}$ to $+85^\circ\text{C}$.

Symbol	Parameter	Condition	Min.	Typ.	Max.	Units
V_{DD}, V_{DDO}	2.5V Operating Voltage		2.375	2.5	2.625	V
V_{DD}, V_{DDO}	3.3V Operating Voltage		3.135	3.3	3.465	V
I_{DD}	Supply current, $V_{DD} + V_{DDO}$	Outputs open		77	98	mA

LVPECL DC Electrical Characteristics⁽⁴⁾

$V_{DD} = V_{DDO} = 3.3V \pm 5\%$ or $2.5V \pm 5\%$

$V_{DD} = 3.3V \pm 5\%$, $V_{DDO} = 3.3V \pm 5\%$ or $2.5V \pm 5\%$

$T_A = -40^\circ\text{C}$ to $+85^\circ\text{C}$. $R_L = 50\Omega$ to $V_{DDO} - 2V$

Symbol	Parameter	Condition	Min.	Typ.	Max.	Units
V_{OH}	Output High Voltage		$V_{DDO} - 1.145$	$V_{DDO} - 0.97$	$V_{DDO} - 0.845$	V
V_{OL}	Output Low Voltage		$V_{DDO} - 1.945$	$V_{DDO} - 1.77$	$V_{DDO} - 1.645$	V
V_{SWING}	Output Voltage Swing		0.6	0.8	1.0	V

Note:

1. Permanent device damage may occur if absolute maximum ratings are exceeded. This is a stress rating only and functional operation is not implied at conditions other than those detailed in the operational sections of this data sheet. Exposure to absolute maximum rating conditions for extended periods may affect device reliability.
2. The data sheet limits are not guaranteed if the device is operated beyond the operating ratings.
3. Package thermal resistance assumes exposed pad is soldered (or equivalent) to the devices most negative potential on the PCB.
4. The circuit is designed to meet the AC and DC specifications shown in the above table(s) after thermal equilibrium has been established.

LVC MOS (PLL_BYPASS) DC Electrical Characteristics⁽⁴⁾

$V_{DD} = 3.3V \pm 5\%$ or $2.5V \pm 5\%$, $T_A = -40^\circ C$ to $+85^\circ C$.

Symbol	Parameter	Condition	Min.	Typ.	Max.	Units
V_{IH}	Input High Voltage		2		$V_{DD} + 0.3$	V
V_{IL}	Input Low Voltage		-0.3		0.8	V
I_{IH}	Input High Current	$V_{DD} = V_{IN} = 3.465V$			150	μA
I_{IL}	Input Low Current	$V_{DD} = 3.465V, V_{IN} = 0V$	-5			μA

REF_IN DC Electrical Characteristics⁽⁴⁾

$V_{DD} = 3.3V \pm 5\%$ or $2.5V \pm 5\%$, $T_A = -40^\circ C$ to $+85^\circ C$.

Symbol	Parameter	Condition	Min.	Typ.	Max.	Units
V_{IH}	Input High Voltage		1.1		$V_{DD} + 0.3$	V
V_{IL}	Input Low Voltage		-0.3		0.6	V
I_{IN}	Input Current	$V_{DD} = 3.465V, V_{IN} = 0V$ to V_{DD}	-5		5	μA

AC Electrical Characteristics^(4, 5)

$V_{DD} = V_{DDO} = 3.3V \pm 5\%$ or $2.5V \pm 5\%$

$V_{DD} = 3.3V \pm 5\%$, $V_{DDO} = 3.3V \pm 5\%$ or $2.5V \pm 5\%$

$T_A = -40^\circ C$ to $+85^\circ C$. $R_L = 50\Omega$ to $V_{DDO} - 2V$

Symbol	Parameter	Condition	Min.	Typ.	Max.	Units
F_{OUT}	Output Frequency			153.6		MHz
F_{REF}	Reference Input Frequency			30.72		MHz
T_R/T_F	LVPECL Output Rise/Fall Time	20% – 80%	80	175	350	ps
ODC	Output Duty Cycle		48	50	52	%
T_{LOCK}	PLL Lock Time				20	ms
$T_{jit}(\emptyset)$	RMS Phase Jitter ⁽⁶⁾	Output = 153.6 MHz Integration Range (2MHz – 20MHz)		99		fs
	Spurious Noise Components	30.72MHz		-70		dBc

Notes:

- All phase noise measurements were taken with an Agilent 5052B phase noise system.
- Ref_IN driven with a low noise source ClockWorks SM802001 programmed for a 30.77MHz CMOS output.

Phase Noise Plot

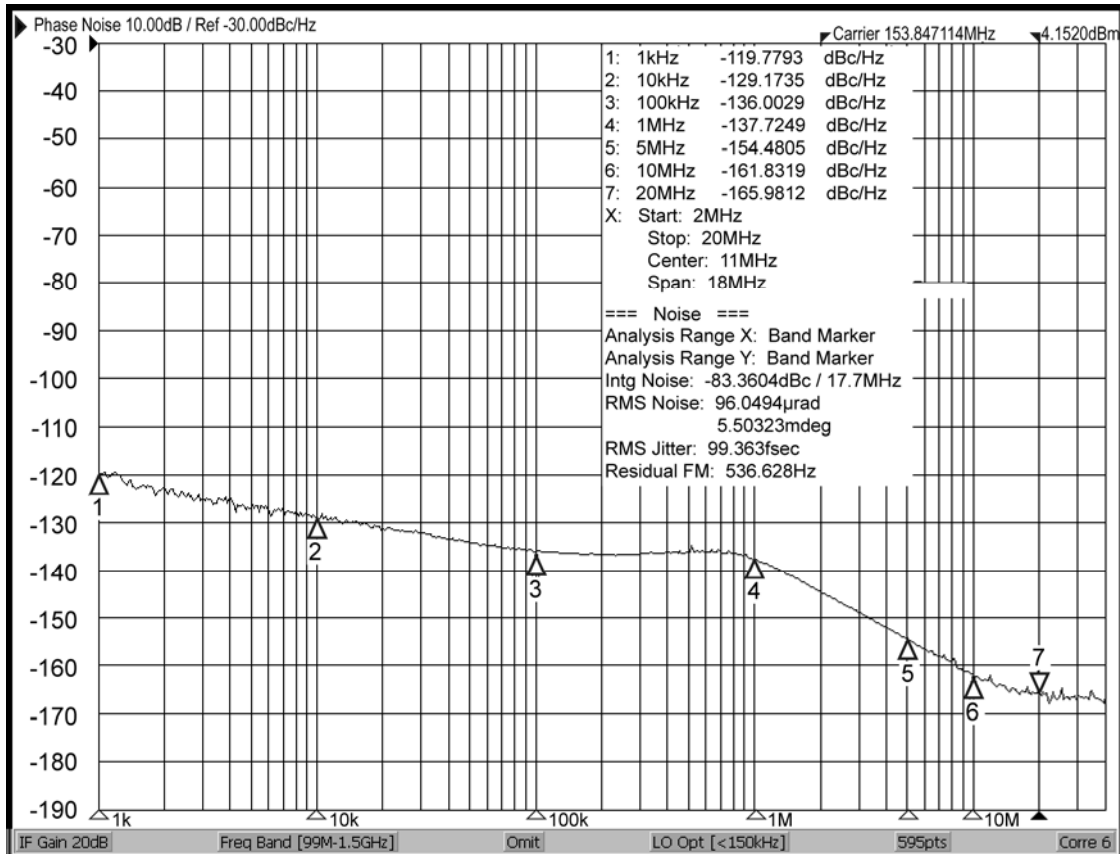

153.8MHz 2MHz-20MHz 99fS
Output is 153.85MHz with a 30.77MHz Input

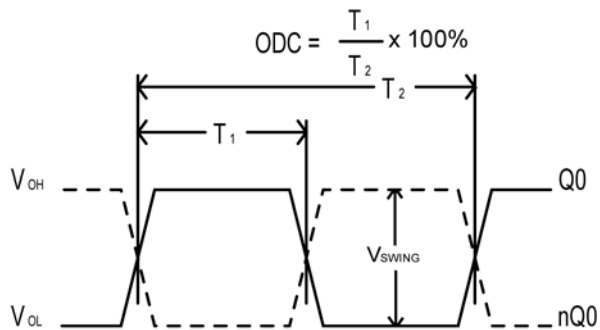

Figure 1. Duty Cycle Timing

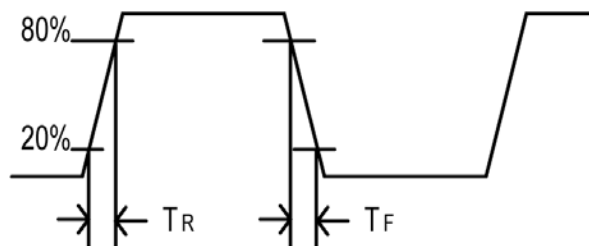

Figure 2. All Outputs Rise/Fall Time

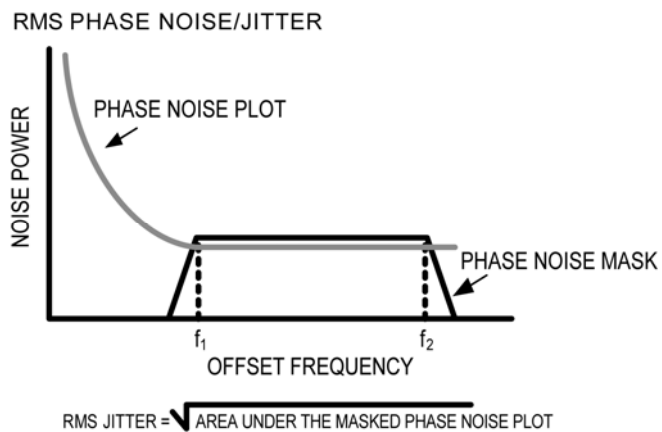

Figure 3. RMS Phase Noise/Jitter

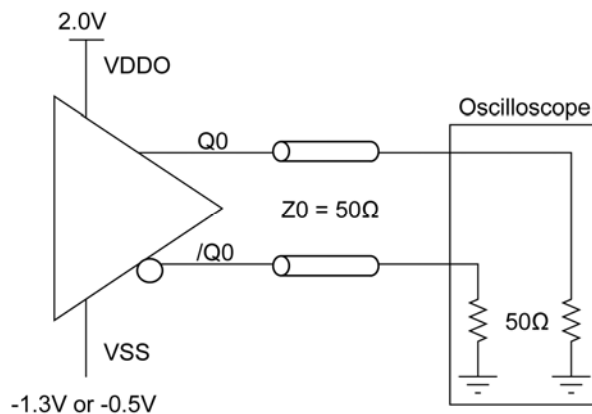
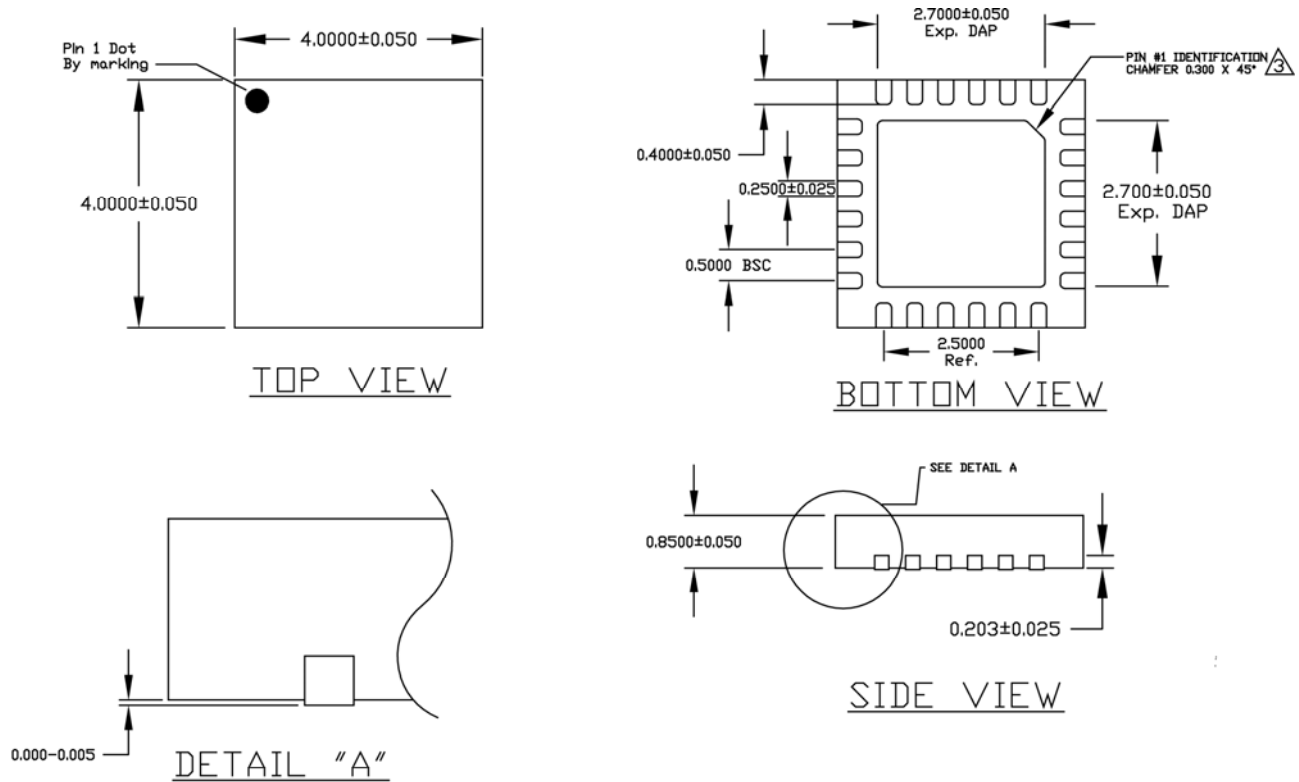



Figure 4. LVPECL Output Load and Test Circuit

Package Information



NOTE:

1. ALL DIMENSIONS ARE IN MILLIMETERS (mm).
2. THE PIN#1 IDENTIFIER MUST EXIST ON THE TOP SURFACE OF PACKAGE BY USING IDENTIFICATION MARK OR OTHER FEATURE OF PACKAGE BODY.

 CHAMFER STYLE PIN 1 IDENTIFIER ON BOTTOM SIDE

24-Pin QFN

MICREL, INC. 2180 FORTUNE DRIVE SAN JOSE, CA 95131 USA
 TEL +1 (408) 944-0800 FAX +1 (408) 474-1000 WEB <http://www.micrel.com>

Micrel makes no representations or warranties with respect to the accuracy or completeness of the information furnished in this data sheet. This information is not intended as a warranty and Micrel does not assume responsibility for its use. Micrel reserves the right to change circuitry, specifications and descriptions at any time without notice. No license, whether express, implied, arising by estoppel or otherwise, to any intellectual property rights is granted by this document. Except as provided in Micrel's terms and conditions of sale for such products, Micrel assumes no liability whatsoever, and Micrel disclaims any express or implied warranty relating to the sale and/or use of Micrel products including liability or warranties relating to fitness for a particular purpose, merchantability, or infringement of any patent, copyright or other intellectual property right.

Micrel Products are not designed or authorized for use as components in life support appliances, devices or systems where malfunction of a product can reasonably be expected to result in personal injury. Life support devices or systems are devices or systems that (a) are intended for surgical implant into the body or (b) support or sustain life, and whose failure to perform can be reasonably expected to result in a significant injury to the user. A Purchaser's use or sale of Micrel Products for use in life support appliances, devices or systems is a Purchaser's own risk and Purchaser agrees to fully indemnify Micrel for any damages resulting from such use or sale.

© 2011 Micrel, Incorporated.