



# MIC2775

## Micro-Power Voltage Supervisor

### General Description

The MIC2775 is a power supply supervisor that provides under-voltage monitoring, manual reset capability, and power-on reset generation in a compact 5-pin SOT package. Features include an under-voltage detector, a delay generator, a manual reset input, and both active-high and active-low reset outputs. The under-voltage detector compares  $V_{DD}$  against a fixed threshold. Ten factory-programmed thresholds are available.

The reset outputs are asserted for no less than 140ms at power-on and any time the input voltage drops below the reference voltage. It remains asserted for the timeout period after the input voltage subsequently rises back above the threshold boundary. A reset can be generated at any time by asserting the manual reset input, /MR. This reset output will remain active at least 140ms after the release of /MR. The /MR input can also be used to daisy-chain the MIC2775 onto existing power monitoring circuitry or other supervisors. Hysteresis is included to prevent chattering due to noise. Typical supply current is a low 3.5 $\mu$ A.

### Features

- Monitors power supply for under-voltage conditions
- Choice of factory-programmed thresholds
- Generates 140ms (minimum) power-on RESET pulse
- Manual reset capability
- Both active-high and active-low RESET outputs
- /RST output valid down to 1.2V
- Ultra-low supply current, 3.5 $\mu$ A typical
- Rejects brief input transients
- No external components
- Pin compatible upgrade for MAX825
- IttyBitty™ 5-pin SOT-23 package

### Applications

- Monitoring processor core and input/output voltages
- Computer systems
- PDAs, hand-held PCs
- Embedded controllers
- Telecommunications systems
- Power supplies

### Ordering Information

Part Number				Junction Temp. Range	Package
Standard	Marking	Pb-Free	Marking		
MIC2775-XXBM5	UJXX	MIC2775-XXYM5	UJXX	-40°C to +85°C	SOT-23-5

### Typical Application

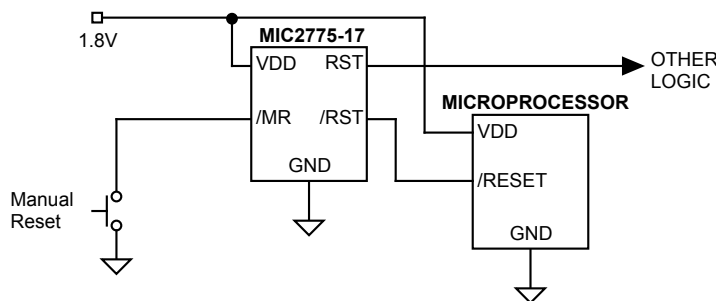

IttyBitty™ is a trademark of Micrel, Inc.

Micrel, Inc. • 2180 Fortune Drive • San Jose, CA 95131 • USA • tel + 1 (408) 944-0800 • fax + 1 (408) 474-1000 • <http://www.micrel.com>

## Standard Voltage Options\*

Voltage Code	Typical Application ( $V_{DD}$ )	Nominal Threshold Voltage ( $V_{TH}$ )
46	5.0V $\pm$ 5%	4.68
44	5.0V $\pm$ 10%	4.43
31	3.3V $\pm$ 5%	3.09
29	3.3V $\pm$ 10%	2.93
28	3.0V $\pm$ 5%	2.81
26	2.85V $\pm$ 5%	2.67
25	2.70V $\pm$ 5%	2.53
23	2.5V $\pm$ 5%	2.34
22	2.4V $\pm$ 5%	2.25
17	1.8V $\pm$ 5%	1.69

\*There are ten standard versions available with an order increment of 3000 pieces. Samples of standard versions are normally available from stock. Contact factory for information on non-standard versions. Available in tape-and-reel only.

## Pin Configuration

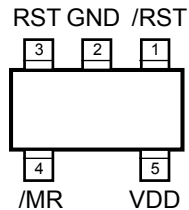

**SOT-23-5 (M5)**

## Pin Description

Pin Number	Pin Name	Pin Function
1	/RST	Digital (Output): Asserted low whenever $V_{DD}$ falls below the reference voltage. It will remain asserted for no less than 140ms after $V_{DD}$ returns above the threshold limit.
2	GND	Ground
3	RST	Digital (Output): Asserted high whenever $V_{DD}$ falls below the reference voltage. It will remain asserted for no less than 140ms after $V_{DD}$ returns above the threshold limit.
4	/MR	Digital (Input): Driving this pin low initiates an immediate and unconditional reset. Assuming $V_{DD}$ is above the threshold when /MR is released (returns high), the reset output will be de-asserted no less than 140ms later. /MR may be driven by a logic signal or a mechanical switch. /MR has an internal pull-up to $V_{DD}$ and may be left open if unused.
5	VDD	Analog (Input): Power supply input and the voltage being monitored.

**Absolute Maximum Ratings (Note 1)**

Supply Voltage ( $V_{DD}$ )	-0.3V to +7V
Input Voltage ( $V_{/MR}$ )	-0.3V to +7V
RST, (/RST) Current	20mA
Storage Temperature ( $T_S$ )	-65°C to +150°C
ESD Rating, <b>Note 3</b>	1.5kV

**Operating Ratings (Note 2)**

Supply Voltage ( $V_{DD}$ )	+1.5V to +5.5V
Input Voltage ( $V_{/MR}$ )	-0.3V to +6.0V
Ambient Temperature Range ( $T_A$ )	-40°C to +85°C
Package Thermal Resistance ( $\theta_{JA}$ )	256°C/W

**Electrical Characteristics**

**Note 5;**  $T_A = +25^\circ\text{C}$ , **bold** values indicate  $-40^\circ\text{C} \leq T_A \leq +85^\circ\text{C}$ ; unless noted

Symbol	Parameter	Condition	Min	Typ	Max	Units
$I_{DD}$	Supply Current	$V_{DD} = V_{TH} + 1.6\%$ , /MR, RST, /RST <b>open, Note 5</b>		3.5		$\mu\text{A}$

**VDD VOLTAGE THRESHOLD**

	Under-Voltage Threshold On $V_{DD}$		$V_{TH} - 1.5\%$	$V_{TH}$	$V_{TH} + 1.5\%$	V V
$V_{HYST}$	Hysteresis Voltage			1		%

**RST, /RST OUTPUTS**

$t_{PROP}$	Propagation Delay	$V_{DD} = V_{TH} + 1.5\% + 100\text{mV}$ to $V_{DD} = V_{TH} - 1.5\% - 100\text{mV}$		20		$\mu\text{s}$
$t_{RST}$	Reset Pulse Width		<b>140</b>		<b>280</b>	<b>ms</b>
$V_{OL}$	RST or /RST Output Voltage Low	$I_{SINK} = 1.6\text{mA}$ ; $V_{DD} \geq 1.6\text{V}$			<b>0.3</b>	V
		$I_{SINK} = 100\mu\text{A}$ ; $V_{DD} \geq 1.2\text{V}$ ; <b>Note 4</b>			<b>0.3</b>	V
$V_{OH}$	RST or /RST Output Voltage High	$I_{SOURCE} = 500\mu\text{A}$ ; $V_{DD} \geq 1.5\text{V}$	<b>0.8</b> $V_{DD}$			V
		$I_{SOURCE} = 10\mu\text{A}$ ; $V_{DD} \geq 1.2\text{V}$ ; <b>Note 4</b>	<b>0.8</b> $V_{DD}$			V

**/MR INPUT**

$V_{IH}$	Input High Voltage		<b>0.7</b> $V_{DD}$			V
$V_{IL}$	Input Low Voltage				<b>0.3</b> $V_{DD}$	V
$t_{PROP}$	Propagation Delay	From $V_{/MR} < (V_{IL} - 100\text{mV})$		5		$\mu\text{s}$
$t_{MIN}$	Minimum Input Pulse Width	Reset Occurs, $V_{/MR} < V_{IL}$		33		ns
$I_{PU}$	Internal Pull-up Current			100		nA
$I_{IN}$	Input Current, /MR	$V_{/MR} < V_{IL}$		100		nA

**Note 1.** Exceeding the absolute maximum rating may damage the device.

**Note 2.** The device is not guaranteed to function outside its operating rating.

**Note 3.** Devices are ESD sensitive. Handling precautions recommended. Human body model, 1.5k in series with 100pF.

**Note 4.**  $V_{DD}$  operating range is 1.5V to 5.5V. Output is guaranteed to be asserted down to  $V_{DD} = 1.2\text{V}$ .

**Note 5.**  $V_{DD}$  equals nominal "Typical Application ( $V_{DD}$ )" as shown in "Standard Voltage Options Table."

# Timing Diagram

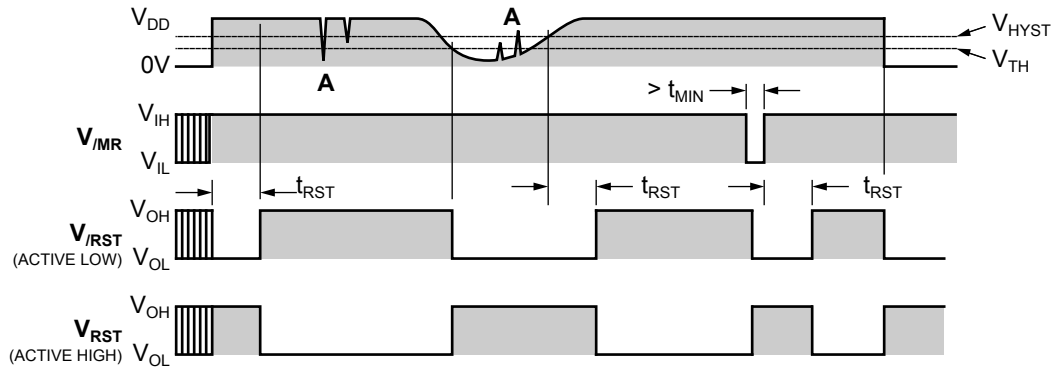

Propagation delays not shown for clarity.

**Note A.** The MIC2775 ignores very brief transients. See "Applications Information" for details.

## Functional Diagram

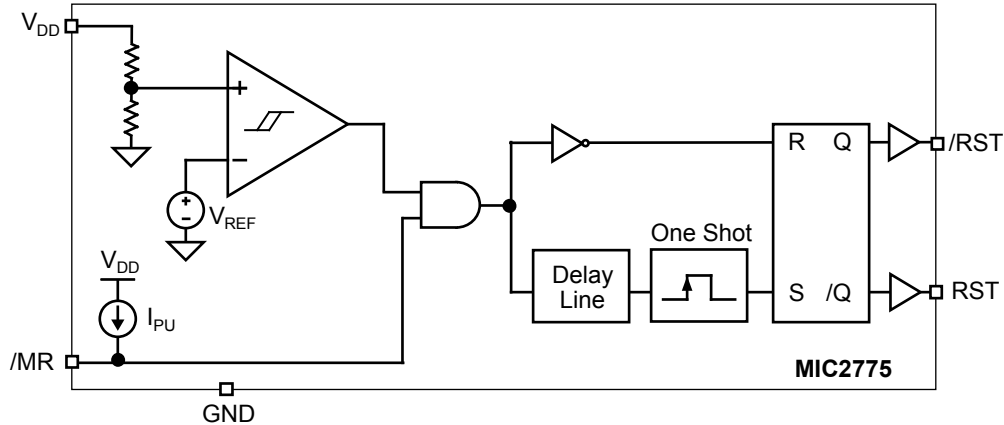

## Functional Description

### $V_{DD}$ Input

The  $V_{DD}$  pin is both the power supply terminal and a monitored input voltage. The voltage at this pin is continually compared against the internal reference. The trip-point at which a reset occurs is factory programmed. A reset is triggered if and when  $V_{DD}$  falls below the trip-point. Hysteresis is employed to prevent chattering due to noise. The comparator on the  $V_{DD}$  input is relatively immune to very brief negative-going transients.

### RST, /RST Reset Outputs

Typically, the MIC2775 is used to monitor the power supply of intelligent circuits such as microcontrollers and microprocessors. By connecting the appropriate reset output of a MIC2775 to the reset input of a  $\mu\text{C}$  or  $\mu\text{P}$ , the processor will be properly reset at power-on and during power-down and brown-out conditions. In addition, asserting /MR, the manual reset input, will activate the reset function.

The reset outputs are asserted any time /MR is asserted or if  $V_{DD}$  drops below the threshold voltage. The reset outputs remain asserted for  $t_{RST}(\text{min})$  after  $V_{DD}$  subsequently returns above the threshold boundary and/or /MR is released. A reset pulse is also generated at power-on. Hysteresis is included in the comparator to prevent chattering of the outputs due to noise.

### /MR, Manual Reset Input

The ability to initiate a reset via external logic or a manual switch is provided in addition to the MIC2775's automatic supervisory functions. Driving the /MR input to a logic low causes an immediate and unconditional reset to occur. Assuming  $V_{DD}$  is within tolerance when /MR is released (returns high), the reset outputs will be de-asserted no less than  $t_{RST}$  later. /MR may be driven by a logic signal or mechanical switch. Typically, a momentary push-button switch is connected such that /MR is shorted to ground when the switch contacts close. The switch may be connected directly between /MR and GND. /MR has an internal 100nA pull-up current to  $V_{DD}$  and may be left open if unused.

## Application Information

### Ensuring Proper Operation at Low Supply

At levels of  $V_{DD}$  below 1.2V, the MIC2775's /RST output cannot turn on sufficiently to produce a valid logic-low on /RST. In this situation, circuits driven by /RST could be allowed to float, causing undesired operation. (In most cases, however, it is expected that the circuits driven by the MIC2775 will be similarly inoperative at  $V_{DD} \leq 1.2V$ .)

If a given application requires that /RST be valid below  $V_{DD} = 1.2V$ , this can be accomplished by adding a pull-down resistor to the /RST output. A value of 100k $\Omega$  is recommended as this is usually an acceptable compromise of quiescent current and pull-down current. The resistor's value is not critical, however. See Figure 1.

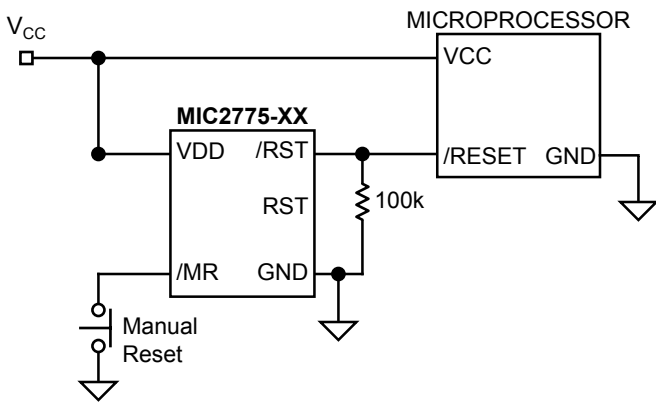

Figure 1. MIC2775 Valid /Reset Below 1.2V

The statements above also apply to the MIC2775's RST output. That is, to ensure valid RST signal levels at  $V_{DD} < 1.2V$ , a pull-up resistor (as opposed to a pull-down) should be added to the RST output. A value of 100k $\Omega$  is typical for this application as well. See Figure 2.

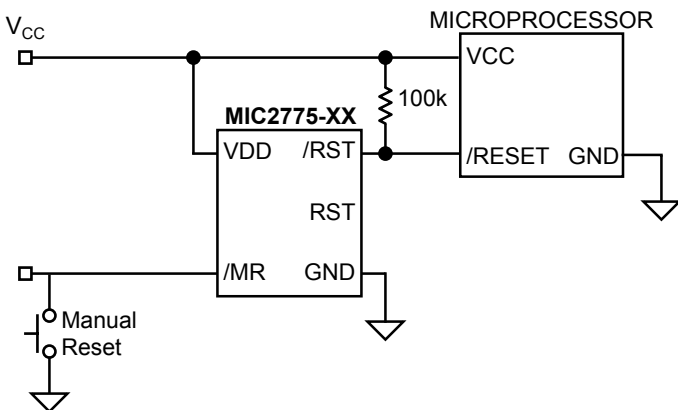

Figure 2. MIC2775 Valid Reset Below 1.2V

### Transient response

The MIC2775 is inherently immune to very short negative-going "glitches." Very brief transients may exceed the voltage threshold without tripping the output.

As shown in Figure 3, in general the narrower the transient, the deeper the threshold overdrive that will be ignored by the MIC2775. The graph represents the typical allowable transient duration for a given amount of threshold overdrive that will not generate a reset.

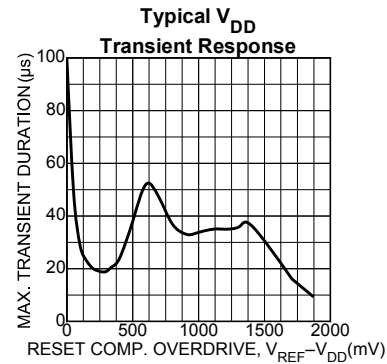
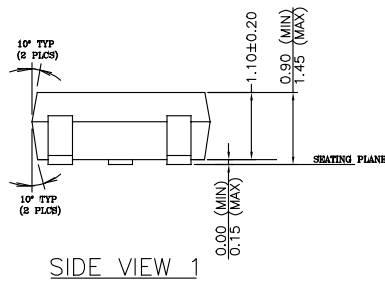
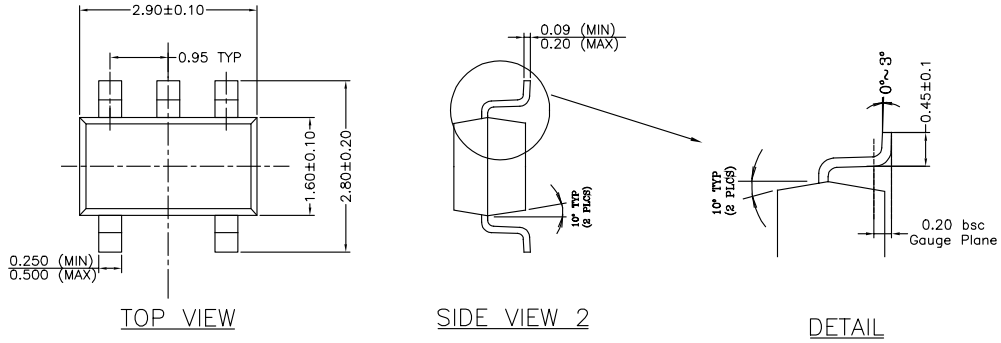

Figure 3. Typical  $V_{DD}$  Transient Response

Package Information



- NOTE:
1. PACKAGE OUTLINE EXCLUSIVE OF MOLD FLASH & BURR.
  2. PACKAGE OUTLINE INCLUSIVE OF SOLER PLATING.
  3. DIMENSION AND TOLERANCE PER ANSI Y14.5M, 1982.
  4. FOOT LENGTH MEASUREMENT BASED ON GAUGE PLANE METHOD.
  5. DIE FACES UP FOR MOLD, AND FACES DOWN FOR TRIM/FORM.

SOT-23-5 (M5)

**MICREL INC. 2180 FORTUNE DRIVE SAN JOSE, CA 95131 USA**  
 TEL + 1 (408) 944-0800 FAX + 1 (408) 474-1000 WEB <http://www.micrel.com>

This information furnished by Micrel in this data sheet is believed to be accurate and reliable. However no responsibility is assumed by Micrel for its use. Micrel reserves the right to change circuitry and specifications at any time without notification to the customer.

Micrel Products are not designed or authorized for use as components in life support appliances, devices or systems where malfunction of a product can reasonably be expected to result in personal injury. Life support devices or systems are devices or systems that (a) are intended for surgical implant into the body or (b) support or sustain life, and whose failure to perform can be reasonably expected to result in a significant injury to the user. A Purchaser's use or sale of Micrel Products for use in life support appliances, devices or systems is a Purchaser's own risk and Purchaser agrees to fully indemnify Micrel for any damages resulting from such use or sale.