

General Description

The MIC5353 is a high-performance, single-output, ultra-low LDO (ULDO™) regulator, offering a low total output noise of $30\mu\text{V}_{\text{RMS}}$. The MIC5353 is capable of sourcing 500mA output current and offers high-PSRR and low-output noise, making it an ideal solution for RF applications.

The MIC5353 provides 2% accuracy, extremely low dropout voltage (160mV @ 500mA), and low ground current (typically 90 μA) making it ideal for battery-operated applications. When disabled, the MIC5353 enters a zero-off-mode current state, thereby drawing almost no current.

The MIC5353 is available in the 1.6mm x 1.6mm Thin MLF® package, occupying only 2.56mm² of PCB area, a 36% reduction in board area compared to SC-70 and 2mm x 2mm Thin MLF® packages.

The MIC5353 has an operating junction temperature range of -40°C to +125°C and is available in fixed and adjustable output voltages in lead-free (RoHS-compliant) Thin MLF® package.

Data sheets and support documentation can be found on Micrel's web site at: www.micrel.com.

Features

- 500mA guaranteed output current
- Input voltage range: 2.6V to 6V
- Ultra low dropout voltage: 160mV @ 500mA
- $\pm 2\%$ initial accuracy
- Ultra low output noise: 30 μV_{rms}
- Low quiescent current: 90 μA
- Stable with ceramic output capacitors
- 35 μs turn-on time
- Thermal shutdown and current limit protection
- Tiny 6-pin 1.6mm x 1.6mm Thin MLF® leadless package

Applications

- Mobile Phones
- GPS, PDAs, PMP, handhelds
- Portable electronics
- Digital still and video cameras
- Digital TV

Typical Application

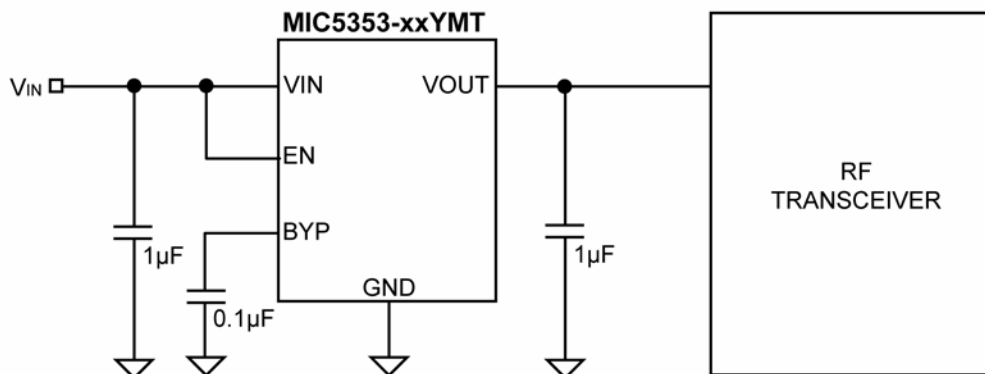

Portable Application

ULDO is a trademark of Micrel, Inc

MLF and MicroLeadFrame are registered trademarks of Amkor Technology, Inc.

Micrel Inc. • 2180 Fortune Drive • San Jose, CA 95131 • USA • tel +1 (408) 944-0800 • fax +1 (408) 474-1000 • <http://www.micrel.com>

Ordering Information

Part Number	Marking Code ⁽¹⁾	Output Voltage ⁽²⁾	Temperature Range	Package
MIC5353-1.8YMT	18R	1.8V	-40°C to +125°C	6-Pin 1.6mm x 1.6mm Thin MLF [®]
MIC5353-2.5YMT	25R	2.5V	-40°C to +125°C	6-Pin 1.6mm x 1.6mm Thin MLF [®]
MIC5353-2.6YMT	26R	2.6V	-40°C to +125°C	6-Pin 1.6mm x 1.6mm Thin MLF [®]
MIC5353-2.8YMT	28R	2.8V	-40°C to +125°C	6-Pin 1.6mm x 1.6mm Thin MLF [®]
MIC5353-3.0YMT	30R	3.0V	-40°C to +125°C	6-Pin 1.6mm x 1.6mm Thin MLF [®]
MIC5353-3.3YMT	33R	3.3V	-40°C to +125°C	6-Pin 1.6mm x 1.6mm Thin MLF [®]
MIC5353YMT	AAR	ADJ	-40°C to +125°C	6-Pin 1.6mm x 1.6mm Thin MLF [®]

Notes:

- Pin 1 identifier= "▲".
- For other voltage options contact Micrel Marketing.
- Thin MLF[®] is a GREEN RoHS compliant package. Lead finish is NiPdAu, Mold compound is Halogen Free.

Pin Configuration

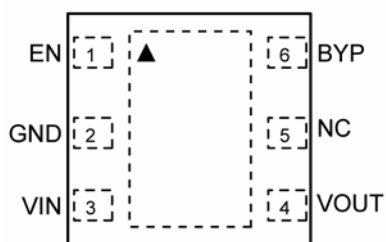

6-Pin 1.6mm x 1.6mm Thin MLF[®] (MT)
Fixed
(TOP VIEW)

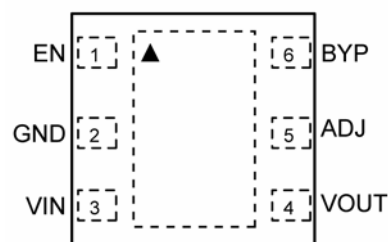

6-Pin 1.6mm x 1.6mm Thin MLF[®] (MT)
Adjustable
(TOP VIEW)

Pin Description

Pin Number Thin MLF-6 Fixed	Pin Number Thin MLF-6 Adjustable	Pin Name	Pin Function
1	1	EN	Enable Input. Active High. High = ON, low = OFF. Do not leave floating.
2	2	GND	Ground.
3	3	VIN	Supply Input.
4	4	VOUT	Output Voltage.
5	–	NC	No connection.
–	5	ADJ	Adjust Input. Connect to external resistor voltage divider network.
6	6	BYP	Reference Bypass: Connect external 0.1μF to GND for reduced Output Noise. May be left open.
EPad	EPad	HS PAD	Exposed Heat-sink Pad connected to ground internally.

Absolute Maximum Ratings⁽¹⁾

Supply Voltage (V_{IN})	-0.3V to +6.5V
Enable Input Voltage (V_{EN})	-0.3V to V_{IN}
Power Dissipation	Internally Limited ⁽³⁾
Lead Temperature (soldering, 3sec)	260°C
Storage Temperature (T_S)	-65°C to +150°C
ESD Rating ⁽⁴⁾	2KV

Operating Ratings⁽²⁾

Supply Voltage (V_{IN})	+2.6V to +6.0V
Enable Input Voltage (V_{EN})	0V to V_{IN}
Junction Temperature (T_J)	-40°C to +125°C
Junction Thermal Resistance	
6-Pin 1.6mm x1.6mm Thin MLF [®] (θ_{JA})	92.4°C/W

Electrical Characteristics⁽⁵⁾

$V_{IN} = V_{OUT} + 1.0V$; $C_{OUT} = 1.0\mu F$; $I_{OUT} = 100\mu A$; $T_J = 25^\circ C$, **bold** values indicate -40°C to +125°C, unless noted.

Parameter	Conditions	Min.	Typ.	Max.	Units
Output Voltage Accuracy	Variation from nominal V_{OUT}	-2.0		+2.0	%
	Variation from nominal V_{OUT} ; -40°C to +125°C	-3.0		+3.0	
Line Regulation	$V_{IN} = V_{OUT} + 1V$ to 6V; $I_{OUT} = 100\mu A$		0.05	0.3	% / V
				0.6	
Load Regulation	$I_{OUT} = 100\mu A$ to 500mA		0.15	2.0	%
Dropout Voltage ⁽⁶⁾	$I_{OUT} = 150mA$		50	100	mV
	$I_{OUT} = 300mA$		100	200	
	$I_{OUT} = 500mA$		160	350	
Ground Pin Current	$I_{OUT} = 0$ to 500mA		90	175	μA
Ground Pin Current in Shutdown	$V_{EN} \leq 0.2V$		0.01	2	μA
Ripple Rejection	$f = 1kHz$; $C_{OUT} = 1.0\mu F$; $C_{BYP} = 0.1\mu F$		60		dB
	$f = 20kHz$; $C_{OUT} = 1.0\mu F$; $C_{BYP} = 0.1\mu F$		45		
Current Limit	$V_{OUT} = 0V$	600	1100	1600	mA
Output Voltage Noise	$C_{OUT} = 1.0\mu F$; $C_{BYP} = 0.1\mu F$; 10Hz to 100kHz		30		μV_{RMS}
Enable Input					
Enable Input Voltage	Logic Low			0.2	V
	Logic High	1.2			
Enable Input Current	$V_{IL} \leq 0.2V$		0.01	1	μA
	$V_{IH} \geq 1.2V$		0.01	1	
Turn-on Time					
Turn-on Time	$C_{OUT} = 1.0\mu F$; $C_{BYP} = 0.1\mu F$		35	100	μs

Notes:

- Exceeding the absolute maximum rating may damage the device.
- The device is not guaranteed to function outside its operating rating.
- The maximum allowable power dissipation of any T_A (ambient temperature) is $P_{D(max)} = (T_{J(max)} - T_A) / \theta_{JA}$. Exceeding the maximum allowable power dissipation will result in excessive die temperature, and the regulator will go into thermal shutdown.
- Devices are ESD sensitive. Handling precautions recommended. Human body model 1.5K Ω in series with 100pF.
- Specification for packaged product only.
- Dropout voltage is defined as the input-to-output differential at which the output voltage drops 2% below its nominal value measured at 1V differential.

Functional Diagram

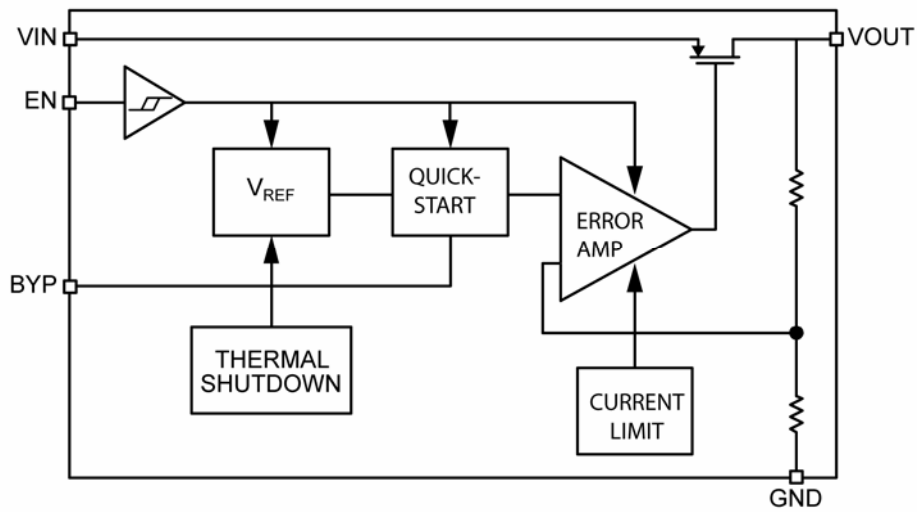

MIC5353 Block Diagram – FIXED

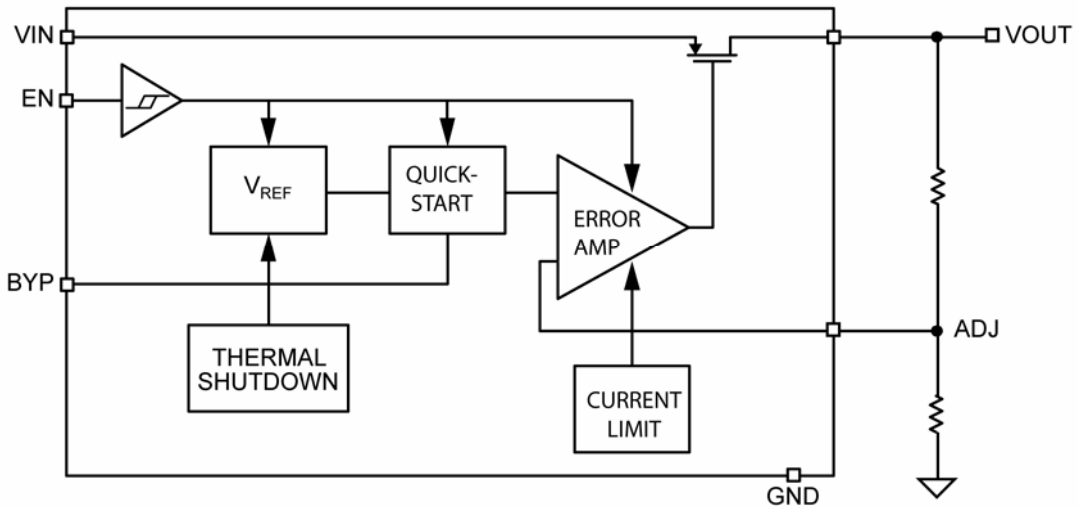

MIC5353 Block Diagram – ADJUSTABLE

Typical Characteristics

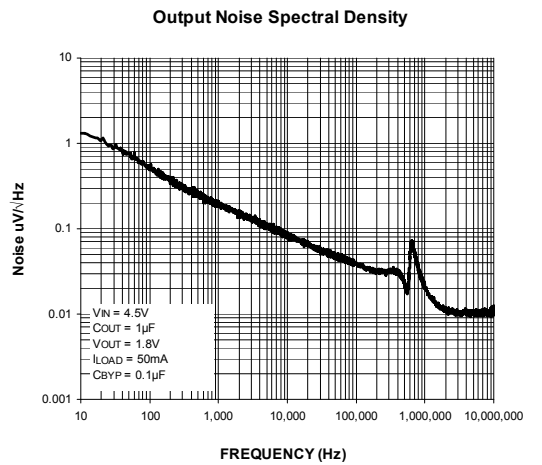
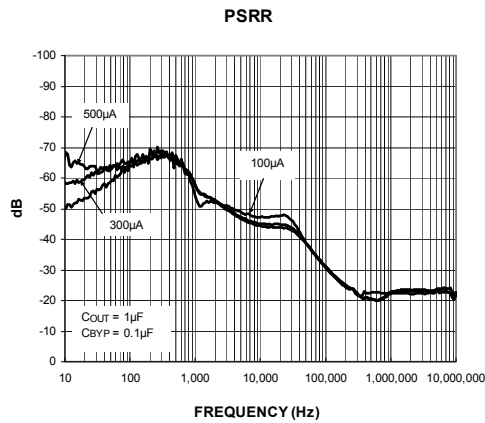
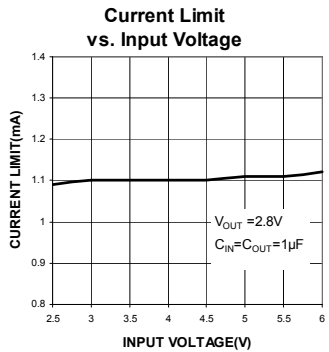
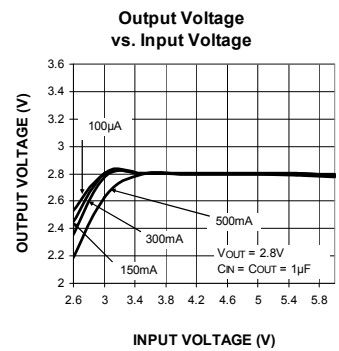
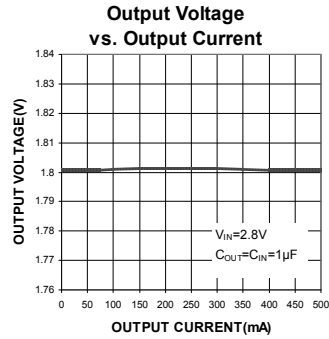
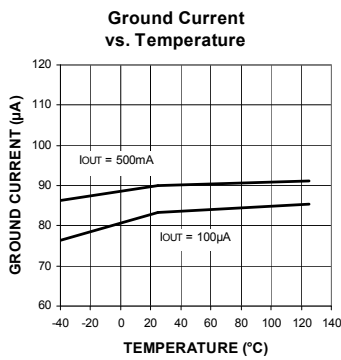
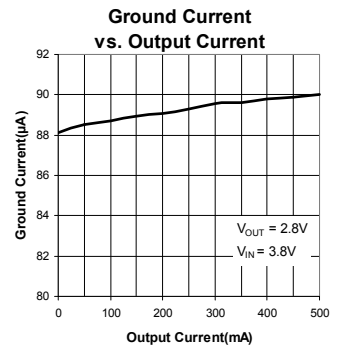
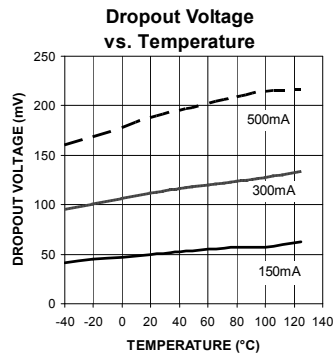
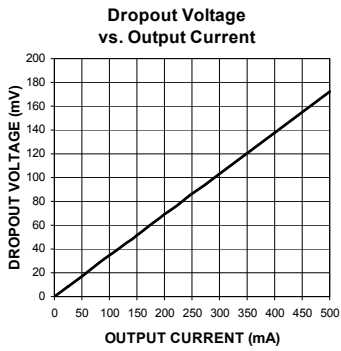

Functional Characteristics

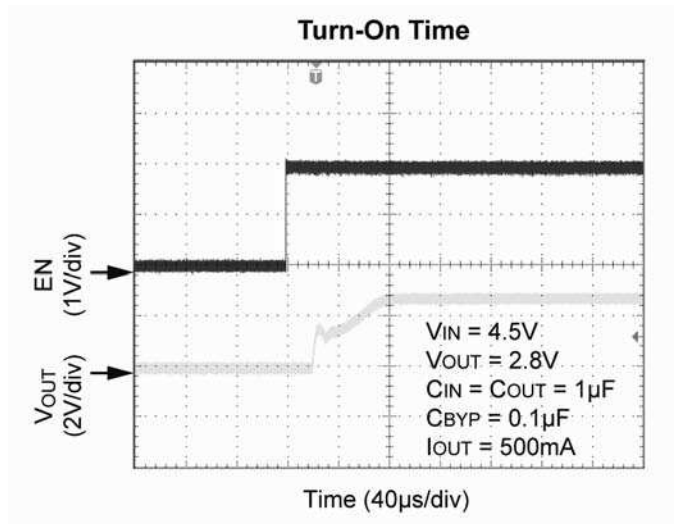
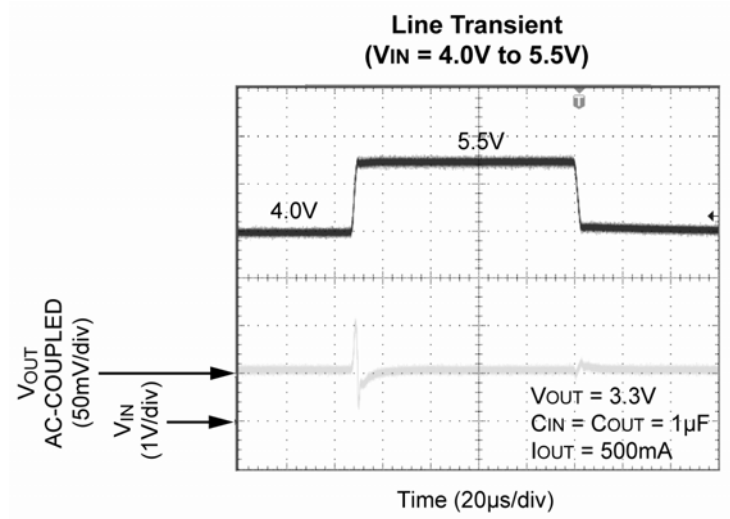
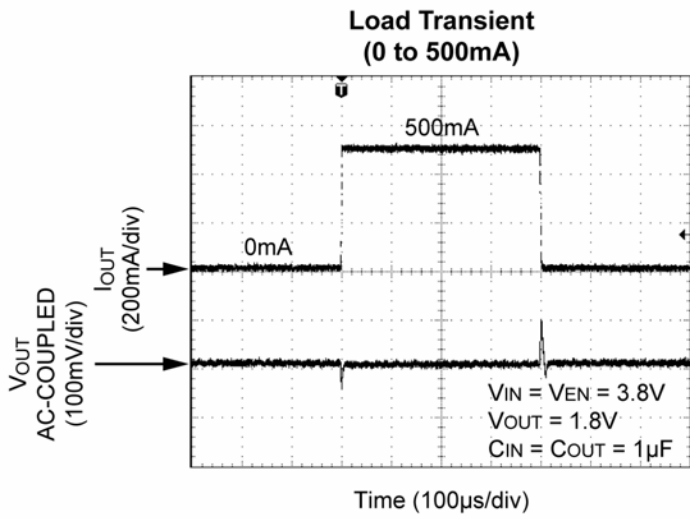

Applications Information

Enable/Shutdown

The MIC5353 comes with an active-high enable pin that allows the regulator to be disabled. Forcing the enable pin low disables the regulator and sends it into a “zero” off-mode-current state. In this state, current consumed by the regulator goes nearly to zero. Forcing the enable pin high enables the output voltage. The active-high enable pin uses CMOS technology and the enable pin cannot be left floating; a floating enable pin may cause an indeterminate state on the output.

Input Capacitor

The MIC5353 is a high-performance, high bandwidth device. Therefore, it requires a well-bypassed input supply for optimal performance. A 1 μ F capacitor is required from the input-to-ground to provide stability. Low-ESR ceramic capacitors provide optimal performance at a minimum of space. The use of additional high-frequency capacitors, such as small-valued NPO dielectric-type capacitors, help filter out high-frequency noise and are good practice in any RF-based circuit.

Output Capacitor

The MIC5353 requires an output capacitor of 1 μ F or greater to maintain stability. The design is optimized for use with low-ESR ceramic chip capacitors. High-ESR capacitors may cause high-frequency oscillation. The output capacitor can be increased, although performance has been optimized for a 1 μ F ceramic output capacitor and doing so does not improve significantly with larger capacitance.

X7R/X5R dielectric-type ceramic capacitors are recommended because of their temperature performance. The X7R-type capacitors change capacitance by 15% over their operating temperature range and are the most stable type of ceramic capacitors. Z5U and Y5V dielectric capacitors change value by as much as 50% and 60%, respectively, over their operating temperature ranges. To use a ceramic chip capacitor with Y5V dielectric, the value must be much higher than an X7R ceramic capacitor thereby ensuring the same minimum capacitance over the equivalent operating temperature range.

Bypass Capacitor

A capacitor can be placed from the noise bypass pin-to-ground to reduce output voltage noise. The capacitor bypasses the internal reference. A 0.1 μ F capacitor is recommended for applications that require low-noise outputs. The bypass capacitor can be increased, further reducing noise and improving PSRR. Turn-on time increases slightly with respect to bypass capacitance.

A unique, quick-start circuit allows the MIC5353 to drive a large capacitor on the bypass pin without significantly slowing turn-on time.

No-Load Stability

Unlike many other voltage regulators, the MIC5353 will remain stable and in regulation with no load. This is especially important in CMOS RAM keep-alive applications.

Adjustable Regulator Application

Adjustable regulators use the ratio of two resistors to multiply the reference voltage to produce the desired output voltage. The MIC5353 can be adjusted from 1.25V to 5.5V by using two external resistors (Figure 1). The resistors set the output voltage based on the following equation:

$$V_{OUT} = V_{REF} \left(1 + \frac{R1}{R2} \right)$$

$$V_{REF} = 1.25V$$

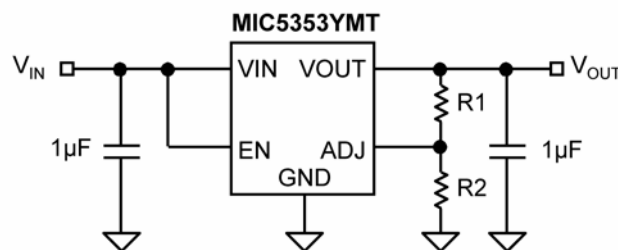

Figure 1. Adjustable Voltage Output

Thermal Considerations

The MIC5353 is designed to provide 500mA of continuous current. Maximum ambient operating temperature can be calculated based on the output current and the voltage drop across the part. Given that the input voltage is 3.3V, the output voltage is 2.8V and the output current = 500mA.

The actual power dissipation of the regulator circuit can be determined using the equation:

$$P_D = (V_{IN} - V_{OUT}) I_{OUT} + V_{IN} I_{GND}$$

Because this device is CMOS and the ground current is typically $<100\mu\text{A}$ over the load range, the power dissipation contributed by the ground current is $< 1\%$ and can be ignored for this calculation:

$$P_D = (3.3\text{V} - 2.8\text{V}) \times 500\text{mA}$$

$$P_D = 0.25\text{W}$$

To determine the maximum ambient operating temperature of the package, use the junction-to-ambient thermal resistance of the device and the following basic equation:

$$P_{D(\text{MAX})} = \left(\frac{T_{J(\text{MAX})} - T_A}{\theta_{JA}} \right)$$

$T_{J(\text{max})} = 125^\circ\text{C}$, the maximum junction temperature of the die θ_{JA} thermal resistance = 92.4°C/W .

Thermal Resistance

Substituting P_D for $P_{D(\text{max})}$ and solving for the ambient operating temperature will give the maximum operating conditions for the regulator circuit. The junction-to-ambient thermal resistance for the minimum footprint is 92.4°C/W .

The maximum power dissipation must not be exceeded for proper operation.

For example, when operating the MIC5353-2.8YMT at an input voltage of 3.3V and 500mA load with a minimum footprint layout, the maximum ambient operating temperature T_A can be determined as follows:

$$0.25\text{W} = (125^\circ\text{C} - T_A)/(92.4^\circ\text{C/W})$$

$$T_A = 101^\circ\text{C}$$

Therefore, a 2.8V application with 500mA of output current can accept an ambient operating temperature of 101°C in a 1.6mm x 1.6mm Thin MLF[®] package. For a full discussion of heat sinking and thermal effects on voltage regulators, refer to the "Regulator Thermals" section of *Micrel's Designing with Low-Dropout Voltage Regulators* handbook. This information can be found on Micrel's website at:

http://www.micrel.com/PDF/other/LDOBk_ds.pdf

Typical Application Schematic (Fixed Output)

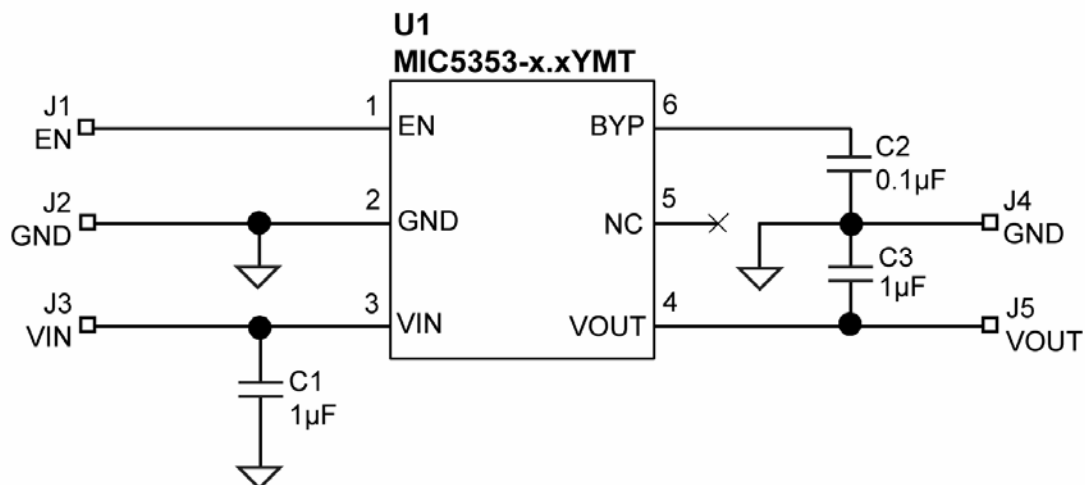

Bill of Materials

Item	Part Number	Manufacturer	Description	Qty.
C1,C3	06036D105KAT2A	AVX ⁽¹⁾	Capacitor, 1µF Ceramic, 6.3V, X5R, Size 0603	2
	GRM188R60J105KE19D	muRata ⁽²⁾		
C2	06035C104KAT2A	AVX ⁽¹⁾	Capacitor, 0.1µF Ceramic, 50V, X5R, Size 0603	1
	GRM188R71H104KA93D	muRata ⁽²⁾		
U1	MIC5353-XXYMT	Micrel, Inc. ⁽³⁾	500mA LDO, 1.6mm x 1.6mm Thin MLF®	1

Notes:

1. AVX: www.avx.com.
2. Murata Tel: www.murata.com.
3. Micrel, Inc.: www.micrel.com.

Typical Application Schematic (Adjustable Output)

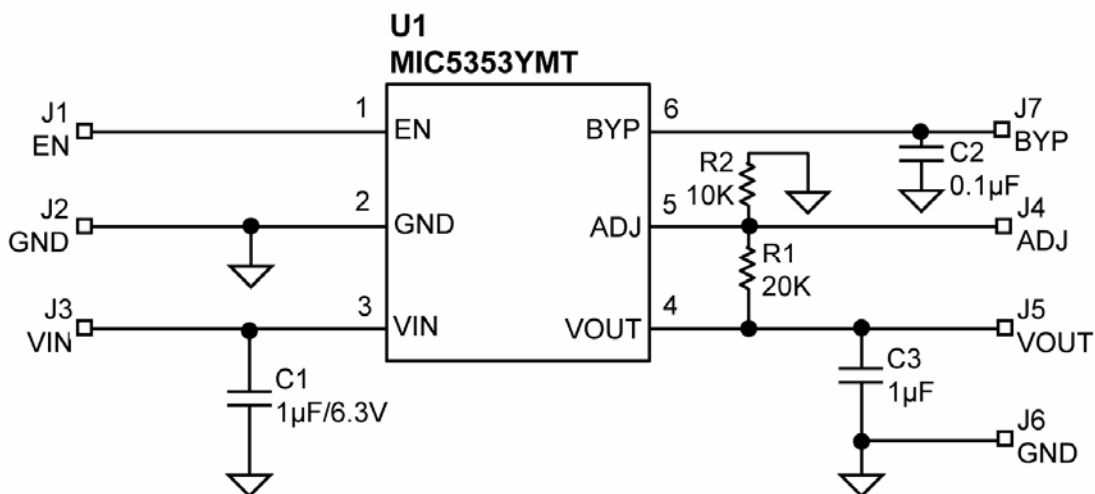

Bill of Materials

Item	Part Number	Manufacturer	Description	Qty.
C1,C3	06036D105KAT2A	AVX ⁽¹⁾	Capacitor, 1µF Ceramic, 6.3V, X5R, Size 0603	2
	GRM188R60J105KE19D	muRata ⁽²⁾		
C2	06035C104KAT2A	AVX ⁽¹⁾	Capacitor, 0.1µF Ceramic, 50V, X5R, Size 0603	1
	GRM188R71H104KA93D	muRata ⁽²⁾		
R1	CRCW060320K0FKEA	Vishay ⁽³⁾	Resistor, 20kΩ, 1%, 1/16W, Size 0603	1
R2	CRCW060310K0FKEA	Vishay ⁽³⁾	Resistor, 10kΩ, 1%, 1/16W, Size 0603	1
U1	MIC5353YMT	Micrel, Inc. ⁽⁴⁾	Adjustable 500mA LDO, 1.6mm x 1.6mm Thin MLF®	1

Notes:

1. AVX: www.avx.com.
2. Murata Tel: www.murata.com.
3. Vishay Tel: www.vishay.com.
4. Micrel, Inc.: www.micrel.com.

PCB Layout Recommendations

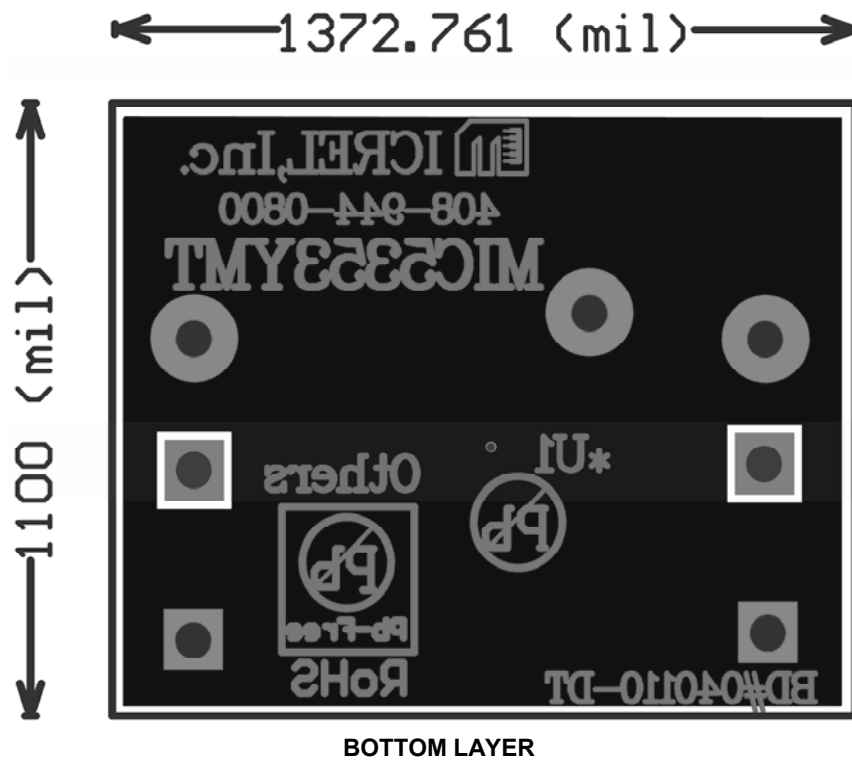
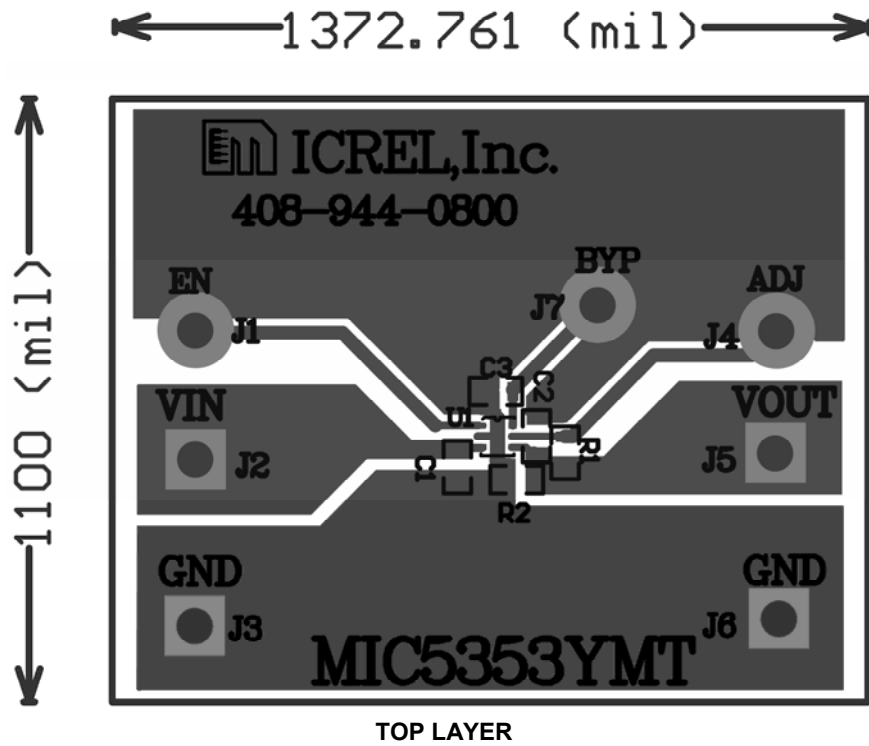

Package Information

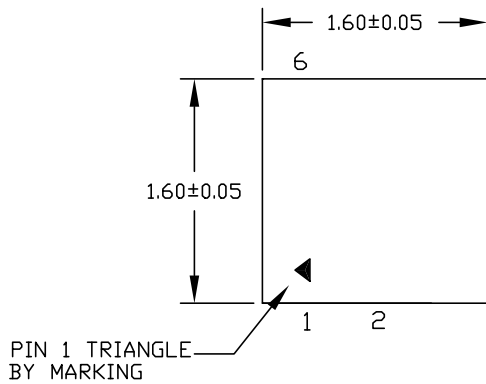

TOP VIEW

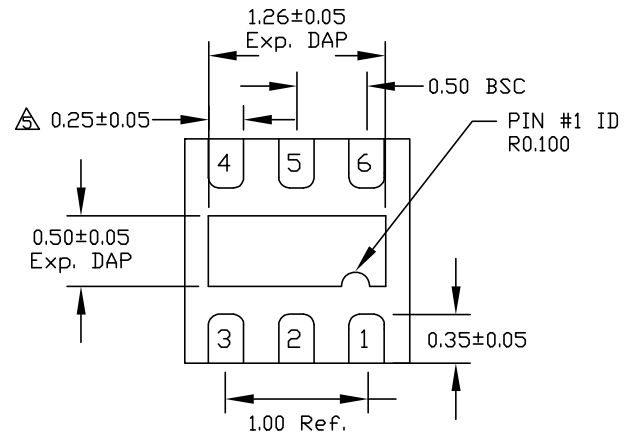

BOTTOM VIEW

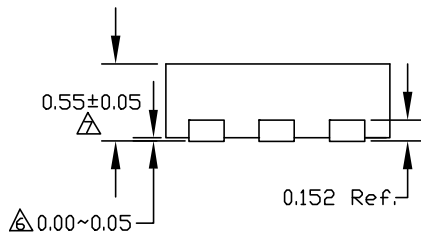

SIDE VIEW

- NOTE:
1. ALL DIMENSIONS ARE IN MILLIMETERS.
 2. MAX. PACKAGE WARPAGE IS 0.05 mm.
 3. MAXIMUM ALLOWABLE BURRS IS 0.076 mm IN ALL DIRECTIONS.
 4. PIN #1 ID ON TOP WILL BE LASER/INK MARKED.
- ⚠ DIMENSION APPLIES TO METALIZED TERMINAL AND IS MEASURED BETWEEN 0.20 AND 0.25 mm FROM TERMINAL TIP.
- ⚠ APPLIED ONLY FOR TERMINALS.
- ⚠ APPLIED FOR EXPOSED PAD AND TERMINALS.

6-Pin 1.6mm x 1.6mm Thin MLF® (MT)

MICREL, INC. 2180 FORTUNE DRIVE SAN JOSE, CA 95131 USA
 TEL +1 (408) 944-0800 FAX +1 (408) 474-1000 WEB <http://www.micrel.com>

The information furnished by Micrel in this data sheet is believed to be accurate and reliable. However, no responsibility is assumed by Micrel for its use. Micrel reserves the right to change circuitry and specifications at any time without notification to the customer.

Micrel Products are not designed or authorized for use as components in life support appliances, devices or systems where malfunction of a product can reasonably be expected to result in personal injury. Life support devices or systems are devices or systems that (a) are intended for surgical implant into the body or (b) support or sustain life, and whose failure to perform can be reasonably expected to result in a significant injury to the user. A Purchaser's use or sale of Micrel Products for use in life support appliances, devices or systems is a Purchaser's own risk and Purchaser agrees to fully indemnify Micrel for any damages resulting from such use or sale.

© 2010 Micrel, Incorporated.