

Motors

EC-motor with planetary gear unit for automated spindle positioning cycles

BG440



BG440

Technical data - electrical ratings

| | |
|-------------------------------|---|
| Voltage supply | 24 (20...30) VDC |
| Ripple residue | <5 % |
| Nominal current | 1.5 A, 2.8 A |
| Nominal rating | 20 W, 40 W |
| Undervoltage interruption | ≤10.5 V |
| External backup | 6.3 AT (required) |
| Excess temperature protection | 120 °C (final power output circuit) |
| Peak current | ≤3.5 A |
| Control signals | Rotation speed 1 Rotation speed 2 Counterclockwise Clockwise Enable |
| Outputs | Motor malfunction (Error) |
| Inputs | Enable Start counterclockwise Start clockwise |

Features

- Brushless EC-DC motor
- With integrated rotation speed electronics
- Nominal power 20 W or 40 W
- Direct connection to spindle position display

Technical data - mechanical design

| | |
|-------------------------|---|
| Operating temperature | -10...+50 °C |
| Protection DIN EN 60529 | IP 54 |
| Connection | - Round connector 8-pin, motor supply - Round connector 12-pin, between motor - SPA DIN45326, Binder series 723 |
| Nominal torque | ≤2.4 Nm (with 20 W) ≤4.4 Nm (with 40 W) |
| Starting torque | ≤5 Nm (with 20 W) ≤10 Nm (with 40 W) |
| Operating speed | ≤72 rpm (highspeed) ≤4 rpm (slowspeed) |
| Scaling ratio | 50:1 |
| Number of stages | 2 |
| Degree of efficiency | 0.81 |
| Shaft loading | ≤500 N axial ≤350 N radial |
| Dimensions W x H x L | See dimensional drawing |
| Weight approx. | 1300 g (type: BG440.25), 1400 g (type: BG440.50) |
| Material | Aluminium profile, anodized in black |

Motors

EC-motor with planetary gear unit for automated spindle positioning cycles

BG440

Part number

| | | | | |
|--------|----|---|----|------------------------|
| BG440. | | 0 | 52 | 01 |
| | | | | Firmware |
| | | | | 01 Firmware version 01 |
| | | | | Gear transmission |
| | | | 52 | ø52 mm |
| | | | | Scaling |
| | | 0 | | 50:1 |
| | | | | Performance |
| | 25 | | | 20 W |
| | 50 | | | 40 W |

Description

Motors of the BG440 series are EC motors (brushless DC-motors) with integrated rotation speed electronics. BG440 series comprises two designs with different dimensions and output power of 20 W and 40 W. The EC motor featuring a fully assembled planetary gear unit is a compact drive in electric spindle positioning operations of the multi-conDrive system.

It provides a separate round connector output enabling direct motor connection to the spindle position display (N 142, N 152). This "interface" provides the motor with the control signals for "clockwise", "counterclockwise" and "off" as well as with the signal for recalling two permanent motor speed parameters relating to high and low speed. Already predefined ramps for acceleration respectively deceleration secure smooth motor start and slow-down.

Accessories

Connectors and cables

| | |
|-----------|--|
| Z 165.M01 | Motor supply cable 1.5 m, 8-pin mating connector |
| Z 165.M02 | Motor supply cable 3 m, 8-pin mating connector |
| Z 165.M03 | Motor supply cable 10 m, 8-pin mating connector |

Motors

EC-motor with planetary gear unit for automated spindle positioning cycles

BG440

Terminal assignment

Connector – Motor, 8-pin

| Connector | Assignment | Function |
|-----------|----------------|--|
| Pin 1 | U _E | +24 VDC motor supply |
| Pin 2 | GND | 0 V related to ground für U _E |
| Pin 3 | OUT left | Release counterclockwise |
| Pin 4 | IN left | Release counterclockwise |
| Pin 5 | OUT right | Release clockwise |
| Pin 6 | IN right | Release clockwise |
| Pin 7 | Enable | Logic +24 V |
| Pin 8 | n.c. | n.c. |

Connector – SPA, 12-pin

| Connector | Assignment | Function |
|-----------|------------|--------------|
| Pin A | – | – |
| Pin B | IN 1 | Motor left |
| Pin C | IN 2 | Motor right |
| Pin D | IN 4* | Speed |
| Pin E | +24 V | n.c. |
| Pin F | n.c. | n.c. |
| Pin G | n.c. | n.c. |
| Pin H | – | n.c. |
| Pin J | – | n.c. |
| Pin K | OUT 3 | Error signal |
| Pin L | IN 3* | Speed |
| Pin M | GND | GND |

| IN 3* | IN 4* | Rotation speed |
|-------|-------|----------------|
| 1 | 0 | 200 |
| 1 | 1 | 3600 |

Circuit diagram

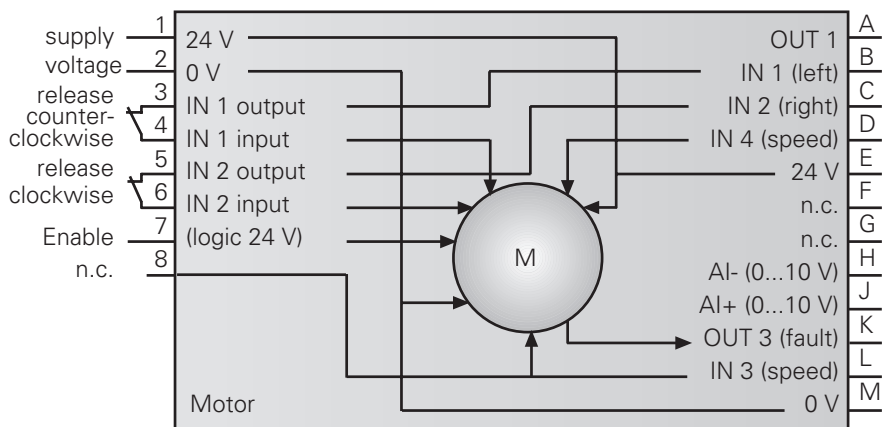

Motors

EC-motor with planetary gear unit for automated spindle positioning cycles

BG440

Dimensions

