

Absolute encoders - SSI

Hollow shaft $\varnothing 10$ to $\varnothing 14$ mm

Optical single- or multiturn encoders max. 14 bit ST / 24 bit MT

ATD 2S A 4 Y 7



ATD 2S A 4 Y 7 with hollow shaft

Features

- Encoder single- or multiturn / SSI
- Optical sensing
- Resolution: max. singleturn 14 bit, multiturn 24 bit
- Hollow shaft $\varnothing 10$ -14 mm
- Self-diagnostic
- Electronic zero point adjustment
- Flange socket radial

Optional

- Incremental signals

Technical data - electrical ratings

Voltage supply	10...30 VDC
Reverse polarity protection	Yes
Consumption w/o load	≤ 70 mA (24 VDC)
Interface	SSI
Function	Singleturn Multiturn
Steps per turn	≤ 16384 / 14 bit
Number of turns	≤ 16777216 / 24 bit
Incremental output	2048 pulses A90°B (optional) 2048 pulses (sin/cos)
Offset sine/cosine amplitude	≤ 1 V _{ss} at Z0 (120 Ohms)
Overlying constant share	≤ 2.5 V
Sensing method	Optical
Code	Gray or binary
Code sequence	CW: ascending values with clockwise sense of rotation (looking at mounting surface)
Inputs	SSI clock Reset input
Output circuit	SSI data: linedriver RS485 Diagnostic output: error
Interference immunity	DIN EN 61000-6-2
Emitted interference	DIN EN 55011

Technical data - mechanical design

Dimensions (flange)	$\varnothing 58$ mm
Shaft	$\varnothing 10$ mm hollow shaft $\varnothing 12$ mm hollow shaft $\varnothing 14$ mm hollow shaft
Protection DIN EN 60529	IP 65
Operating speed	≤ 8000 rpm (mechanical) ≤ 8000 rpm (electric)
Starting torque	≤ 0.02 Nm
Materials	Housing: aluminium Shaft: stainless steel
Operating temperature	-20...+85 °C
Relative humidity	90 % non-condensing
Resistance	DIN EN 60068-2-6 Vibration 10 g, 55-2000 Hz DIN EN 60068-2-27 Shock 30 g, 11 ms
Weight approx.	325 g
Connection	Connector M23 type 2, 12-pin Connector M23 type 2, 17-pin
Motor shaft tolerance	0.25 mm axial 0.1 mm radial
Mounting kit variant	002

Absolute encoders - SSI

Hollow shaft $\varnothing 10$ to $\varnothing 14$ mm

Optical single- or multiturn encoders max. 14 bit ST / 24 bit MT

ATD 2S A 4 Y 7

Terminal significance	
UB	Encoder supply voltage.
GND	Encoder ground connection relating to UB.
Data+	Positive, serial data output of differential linedriver.
Data-	Negative, serial data output of differential-linedriver.
Clock+	Positive SSI clock input. Clock+ together with clock- forms a current loop. A current of approx. 7 mA towards clock+ input means logic 1 in positive logic.
Clock-	Negative SSI clock input. Clock- together with clock+ forms a current loop. A current of approx. 7 mA towards clock- input means logic 0 in positive logic.
Reset	Reset input for setting zero position value at any desired point within the entire resolution. The resetting process is triggered by apply of UB.
V/\bar{R}	V/\bar{R} counting direction input. This input is standard on High. V/\bar{R} means increasing values with clockwise shaft rotation when looking at the mounting side. V/\bar{R} -Low means decreasing values with clockwise shaft rotation when looking at the mounting side.
Error	Diagnostic output (Open Collector with internal 10 k Ω pullup-resistor). The output is high-active, that means if no fault submitted, the output is to GND interconnected.

Terminal assignment	
ATD 2S A 4 Y 7	
Connector	Assignment
Pin 1	clock-
Pin 2	clock+
Pin 3	data+
Pin 4	data-
Pin 5	–
Pin 6	–
Pin 7	reset
Pin 8	V/\bar{R}
Pin 9	–
Pin 10	error
Pin 11	UB
Pin 12	GND

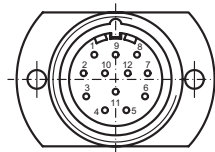

ATD 2S A 4 Y 7 with incremental output signals

Connector	Assignment
Pin 1	clock-
Pin 2	clock+
Pin 3	data+
Pin 4	data-
Pin 5	–
Pin 6	–
Pin 7	reset
Pin 8	V/\bar{R}
Pin 9	–
Pin 10	error
Pin 11	UB
Pin 12	GND
Pin 13	–
Pin 14	track A+
Pin 15	track A-
Pin 16	track B+
Pin 17	track B-

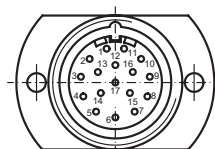

Absolute encoders - SSI

Hollow shaft $\varnothing 10$ to $\varnothing 14$ mm

Optical single- or multiturn encoders max. 14 bit ST / 24 bit MT

ATD 2S A 4 Y 7

Trigger level

SSI	Circuit
SSI-Clock	Optocoupler
SSI-Data	Linedriver RS485

Control input

Control input	Input circuit
Input level High	$\geq 0,7 U_B$
Input level Low	$\leq 0,3 U_B$
Input resistance	10 k Ω

Diagnostic outputs

Diagnostic outputs	Output circuit
Output level	Open Collector with internal 10 k Ω PullUp-resistance

Incremental outputs

Incremental outputs	Line Driver short-circuit proof
Output level High	$\geq U_B - 3 V$
Output level Low	$\leq 0,5 V$
Load	≤ 30 mA

Outputs

Outputs	Sine / Cosine
Output level	1 V _{PP} at Z ₀ = 120 Ω

Data transfer

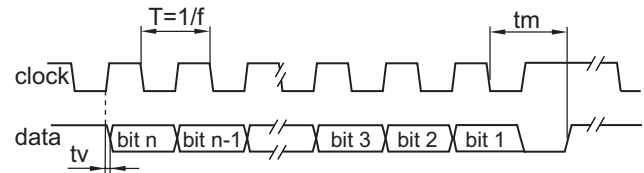

Clock frequency f	80...1000 kHz
Scan ratio of T	40...60 %
Time lag tv	150 ns
Monoflop time tm	20 μ s + T/2
Clock interval tp	26 μ s

Dimensions

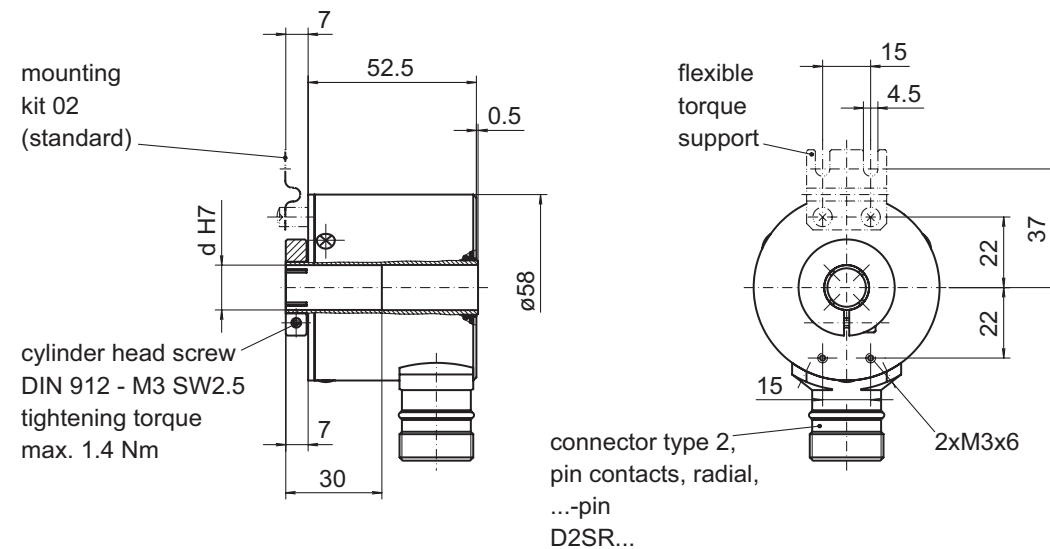

028- 5 Y 7