

Absolute encoders - analogue

Shaft $\varnothing 6$ mm with synchro flange

Optical singleturn encoders with analogue output

ATD 2A B14 Y 1



ATD 2A B14 Y 1 with synchro flange

Features

- Analog signals
- 14 bit singleturn
- Internal self-diagnostic
- Voltage output or current output
- Factory-set adjustable angle ($0^\circ - 360^\circ$)
- Centering alignment $\varnothing 50$ mm, mounting screw hole circle $\varnothing 68$ mm
- Flange socket radial
- Easy signal processing

Technical data - electrical ratings

Voltage supply	12...30 VDC
Reverse polarity protection	Yes
Consumption w/o load	≤ 50 mA (24 VDC)
Interface analog	IS (current output, 4...20 mA) IE (current output, 0...20 mA) US (voltage output, 0...10 VDC) UE (voltage output, -10...+10 VDC) UT (voltage output, 0...5 VDC) UR (voltage output, -5...5 VDC)
Function	Singleturn
Measuring range	90° , 180° , 360°
Load resistance	≥ 1 k Ω (recommended 10 k Ω) / voltage output ≤ 500 Ω (recommended 470 Ω) / current output
Resolution	14 bit
Sensing method	Optical
Updating values	≤ 130 μ s
Code sequence	CW: ascending values with clockwise sense of rotation (looking at mounting surface)
Output circuit	Voltage output (short-circuit proof) Current output (short-circuit proof)
Interference immunity	DIN EN 61000-6-2
Emitted interference	DIN EN 55011

Technical data - mechanical design

Dimensions (flange)	$\varnothing 58$ mm
Shaft	$\varnothing 6$ mm
Flange	Synchro flange
Protection DIN EN 60529	IP 65
Operating speed	≤ 12000 rpm (mechanical) ≤ 6000 rpm (electric)
Starting torque	≤ 0.01 Nm
Shaft loading	≤ 20 N axial ≤ 40 N radial
Materials	Housing: aluminium Shaft: stainless steel
Operating temperature	$-20...+85$ $^\circ$ C
Relative humidity	90 % non-condensing
Resistance	DIN EN 60068-2-6 Vibration 10 g, 55-2000 Hz DIN EN 60068-2-27 Shock 30 g, 11 ms
Weight approx.	430 g
Connection	Connector M23 type 2, 12-pin

Absolute encoders - analogue

Shaft ø6 mm with synchro flange

Optical singleturn encoders with analogue output

ATD 2A B14 Y 1

Part number

ATD 2A B14 Y 1

		D2SR12	S	6	IP65
--	--	--------	---	---	------

					<u>Protection</u> IP65 IP 65
					<u>Flange / Shaft</u> 6 Synchro flange / ø6 mm
					<u>Operating temperature</u> S -20...+85 °C
					<u>Connection</u> D2SR12 Flange socket type 2, pin contacts, radial, 12-pin
					<u>Interface</u>
					IS Current output, standard, 4...20 mA
					IE Current output, extended, 0...20 mA
					US Voltage output, standard, 0...+10 VDC
					UE Voltage output, extended, -10...+10 VDC
					UT Voltage output, TTL, 0...+5 VDC
					UR Voltage output, reduced, -5...+5 VDC
					<u>Resolution</u>
					360A 360° mech. angle of rotation, alternating (singleturn)
					180A 180° mech. angle of rotation, alternating (singleturn)
					180H 180° mech. angle of rotation, High (singleturn)
					180L 180° mech. angle of rotation, Low (Singleturn)

Additional Adjustment on demand

Accessories

Connectors and cables

11070180	Connector S2BG12 with cable (ATD analogue) L = 10 m
----------	---

Mounting accessories

11065545	Set of eccentric fixings type A
----------	---------------------------------

Absolute encoders - analogue

Shaft $\varnothing 6$ mm with synchro flange

Optical singleturn encoders with analogue output

ATD 2A B14 Y 1

Output signals

Unipolar Output
(IS-/IE-/US-/UT-version)

Bipolar Output
(UE-/UR-version)

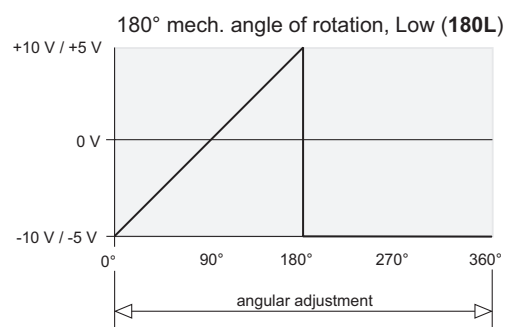
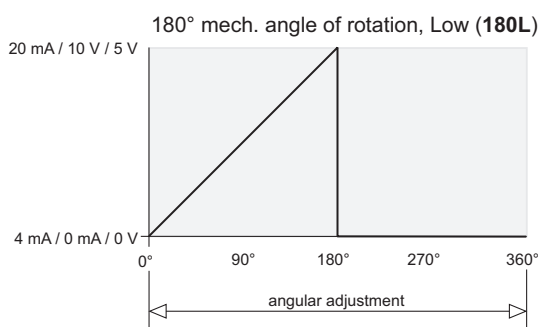
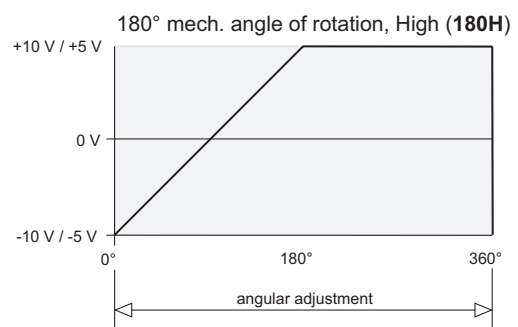
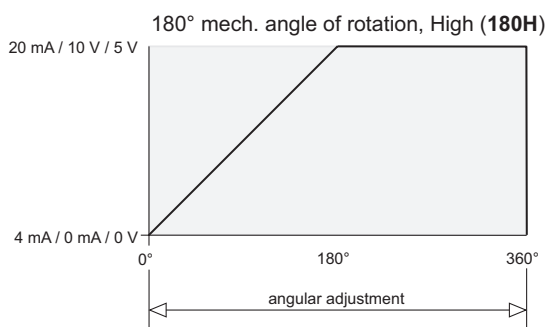
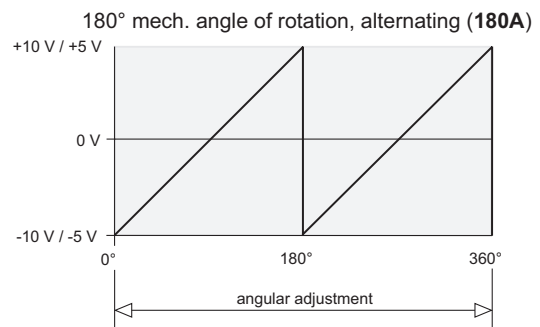
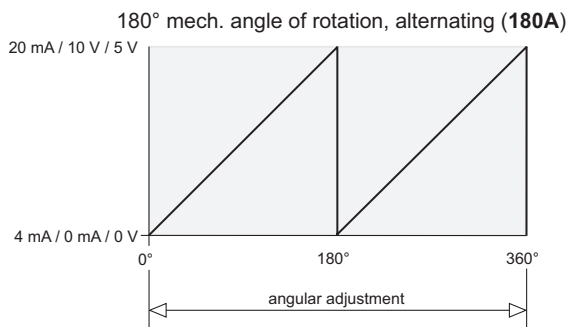
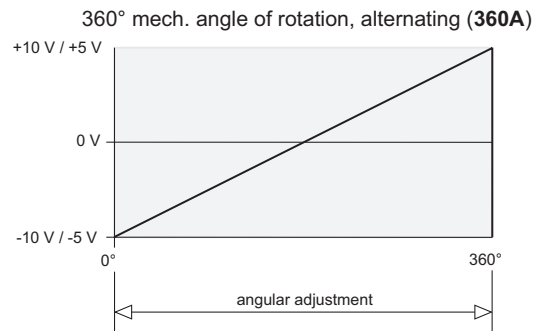
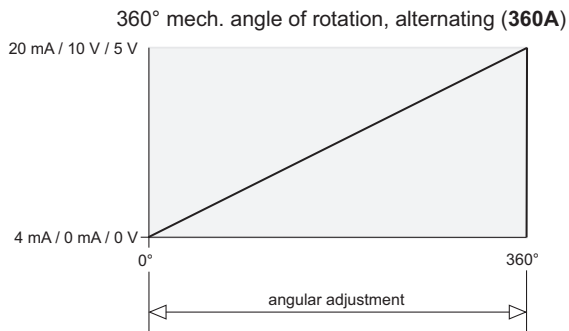

Absolute encoders - analogue

Shaft $\varnothing 6$ mm with synchro flange

Optical singleturn encoders with analogue output

ATD 2A B14 Y 1

Terminal significance

+UB	Encoder supply voltage.
-UB	Negative encoder supply voltage -12 to -26 VDC (only at UE-/UR-version).
GND	Encoder ground connection relating to UB.
U_{OUT}	Voltage output increasing at clockwise rotation when looking at the mounting side.
I_{OUT}	Current output increasing at clockwise rotation when looking at the mounting side.
GND_{OUT}	Reference voltage for analogue output.
Reset	Reset input for setting zero position value at any desired point within the entire resolution. The resetting process is triggered by apply of UB.
V/\bar{R}	V/\bar{R} counting direction input. This input is standard on High. V/\bar{R} means increasing values with clockwise shaft rotation when looking at the mounting side. V/\bar{R} -Low means decreasing values with clockwise shaft rotation when looking at the mounting side.
Error	Diagnostic output (Open Collector with internal 10 k Ω pullup-resistor). The output is low-active, that means if no fault submitted, the output is +UB.

Terminal assignment

ATD 2A B14 Y29

Connector Assignment

Pin 1	-
Pin 2	-
Pin 3	-
Pin 4	GND_{OUT}
Pin 5	U_{OUT} resp. I_{OUT}
Pin 6	-
Pin 7	reset
Pin 8	V/\bar{R}
Pin 9	error
Pin 10	GND
Pin 11	- / -UB (only at UE-/UR-version)
Pin 12	UB

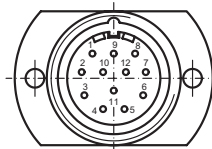

Dimensions

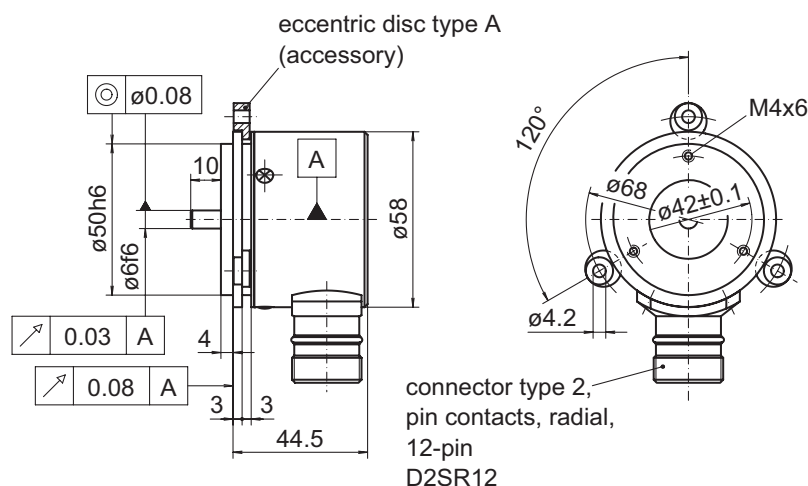

028- 7 Y 1