

Three phase full Bridge

with Trench MOSFETs
in DCB isolated high current package

$V_{DSS} = 100\text{ V}$
 $I_{D25} = 90\text{ A}$
 $R_{DSon\ typ.} = 7.5\text{ m}\Omega$

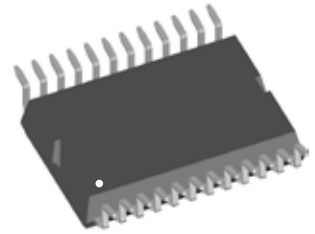
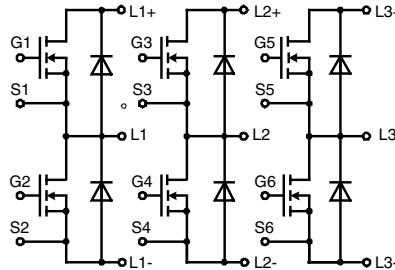

MOSFETs		Maximum Ratings	
Symbol	Conditions		
V_{DSS}	$T_{VJ} = 25^{\circ}\text{C to } 150^{\circ}\text{C}$	100	V
V_{GS}		± 20	V
I_{D25}	$T_C = 25^{\circ}\text{C}$	90	A
I_{D90}	$T_C = 90^{\circ}\text{C}$	68	A
I_{F25}	$T_C = 25^{\circ}\text{C (diode)}$	90	A
I_{F90}	$T_C = 90^{\circ}\text{C (diode)}$	68	A

Applications

- AC drives
- in automobiles
 - electric power steering
 - starter generator
 - in industrial vehicles
 - propulsion drives
 - fork lift drives
 - in battery supplied equipment

Features

- MOSFETs in trench technology:
 - low R_{DSon}
 - optimized intrinsic reverse diode
- package:
 - high level of integration
 - high current capability
 - aux. terminals for MOSFET control
 - terminals for soldering or welding connections
 - isolated DCB ceramic base plate with optimized heat transfer
- Space and weight savings

Symbol	Conditions	Characteristic Values			
		min.	typ.	max.	
$R_{DSon}^{1)}$	on chip level at } $V_{GS} = 10\text{ V}$	$T_{VJ} = 25^{\circ}\text{C}$	7.5	8.5	$\text{m}\Omega$
		$T_{VJ} = 125^{\circ}\text{C}$	14		$\text{m}\Omega$
$V_{GS(th)}$	$V_{DS} = 20\text{ V}; I_D = 1\text{ mA}$		2.5	4.5	V
I_{DSS}	$V_{DS} = V_{DSS}; V_{GS} = 0\text{ V}$	$T_{VJ} = 25^{\circ}\text{C}$		1	μA
		$T_{VJ} = 125^{\circ}\text{C}$	0.1		mA
I_{GSS}	$V_{GS} = \pm 20\text{ V}; V_{DS} = 0\text{ V}$			0.2	μA
Q_g	} $V_{GS} = 10\text{ V}; V_{DS} = 65\text{ V}; I_D = 90\text{ A}$		90		nC
Q_{gs}			30		nC
Q_{gd}			30		nC
$t_{d(on)}$	} inductive load $V_{GS} = 10\text{ V}; V_{DS} = 48\text{ V}$ $I_D = 70\text{ A}; R_G = 33\ \Omega;$ $T_J = 125^{\circ}\text{C}$		130		ns
t_r			95		ns
$t_{d(off)}$			290		ns
t_f			55		ns
E_{on}			0.4		mJ
E_{off}		0.4		mJ	
E_{recoff}		0.007		mJ	
R_{thJC}				1.0	K/W
R_{thJH}	with heat transfer paste (IXYS test setup)		1.3	1.6	K/W

¹⁾ $V_{DS} = I_D \cdot (R_{DS(on)} + 2R_{Pin\ to\ chip})$

Source-Drain Diode

Symbol	Conditions	Characteristic Values		
		min.	typ.	max.
($T_J = 25^\circ\text{C}$, unless otherwise specified)				
V_{SD}	(diode) $I_F = 70\text{ A}$; $V_{GS} = 0\text{ V}$	0.9	1.2	V
t_{rr}	$I_F = 70\text{ A}$; $-di_F/dt = 800\text{ A}/\mu\text{s}$; $V_R = 48\text{ V}$		55	ns
Q_{RM}			0.95	μC
I_{RM}			33	A

Component

Symbol	Conditions	Maximum Ratings	
I_{RMS}	per pin in main current paths (P+, N-, L1, L2, L3) may be additionally limited by external connections 2 pins for output L1, L2, L3	75	A
T_J		-55...+175	$^\circ\text{C}$
T_{stg}		-55...+125	$^\circ\text{C}$
V_{ISOL}	$I_{ISOL} \leq 1\text{ mA}$, 50/60 Hz, $f = 1\text{ minute}$	1000	V~
F_C	mounting force with clip	50 - 250	N

Symbol	Conditions	Characteristic Values		
		min.	typ.	max.
$R_{pin\ to\ chip}^{1)}$			tbd	$\text{m}\Omega$
C_P	coupling capacity between shorted pins and back side metallization		160	pF
Weight			25	g

¹⁾ $V_{DS} = I_D \cdot (R_{DS(on)} + 2R_{Pin\ to\ Chip})$

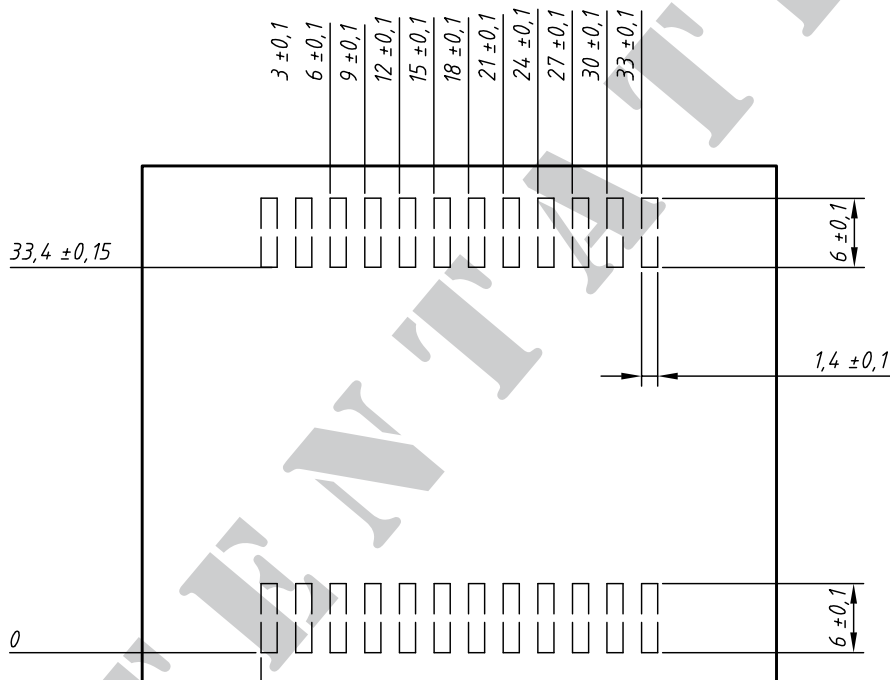

Remarks:

- 1) pin layout / dimensions are conditionally
- 2) soldering paste thickness: 200 μm

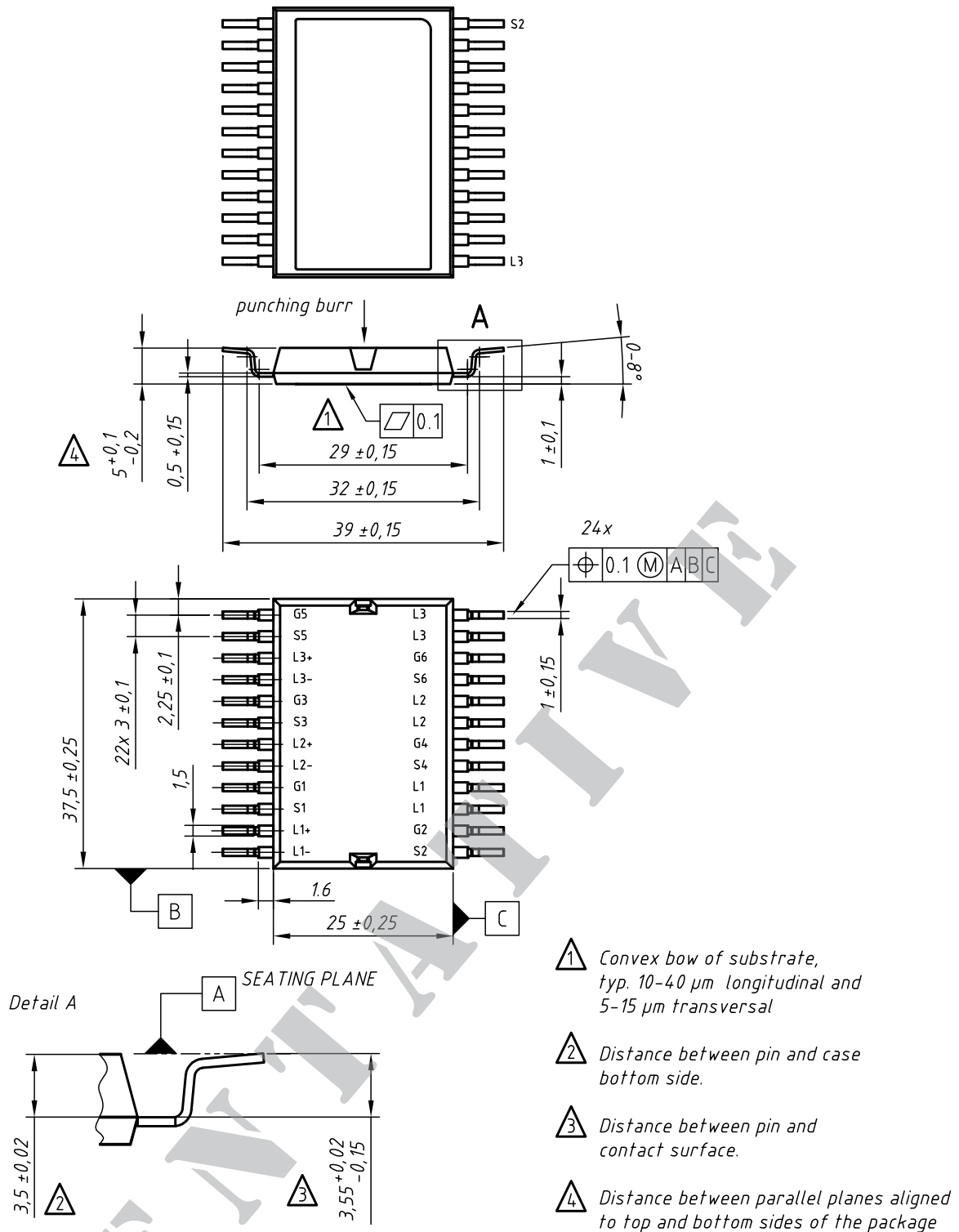

contact pin:

- galv. tin plating, per pin side: Sn 10...25 μ m, undercoating Ni 0,2...1 μ m
- stamping edges may be free of tin
- punching burr: $\leq 0,05$ mm

Leads	Ordering	Part Name & Packing Unit Marking	Part Marking	Delivering Mode	Base Qty.	Ordering Code
SMD	Standard	GMM 3x100-01X1 - SMD	GMM 3x100-01X1	Blister	28	509 035

IXYS reserves the right to change limits, test conditions and dimensions.

20110307