

Incremental encoders

EX approval ATEX EEx d IIC T6

Resolution 5...5000 pulses

X 700 - incremental



X 700 with EX-proof housing

Features

- Encoder incremental / ATEX
- Optical sensing
- Resolution max. 5000 ppr
- Clamping flange with shaft $\varnothing 10$ mm
- Explosion protection per EEx d IIC T6
- Area of application: EX I/II 2 GD
- Device class 2 / zone 1 (gas), zone 21 (dust)
- Material stainless steel

Technical data - electrical ratings

Voltage supply	4.75...30 VDC
Reverse polarity protection	Yes
Consumption w/o load	≤ 50 mA
Resolution (steps/turn)	5...5000
Reference signal	Zero pulse, width 90°
Sensing method	Optical
Output frequency	≤ 300 kHz
Output signals	A 90° B, N + inverted
Output circuit	Push-pull short-circuit proof
Interference immunity	DIN EN 61000-6-2
Emitted interference	DIN EN 61000-6-4

Technical data - mechanical design

Dimensions (flange)	$\varnothing 70$ mm
Shaft	$\varnothing 10$ mm (clamping flange)
Shaft loading	≤ 60 N axial ≤ 50 N radial
Flange	Clamping flange
Protection DIN EN 60529	IP 67
Operating speed	≤ 6000 rpm
Starting torque	≤ 0.04 Nm
Materials	Housing: stainless steel Flange: stainless steel
Operating temperature	$-25...+70$ °C
Relative humidity	95 % non-condensing
Resistance	DIN EN 60068-2-27 Shock 300 g, 1 ms DIN EN 60068-2-27 Shock 100 g, 6 ms
Connection	Cable 2 m (other length upon request)
Weight approx.	1300 g

Output signals

Clockwise rotating direction when looking at flange.

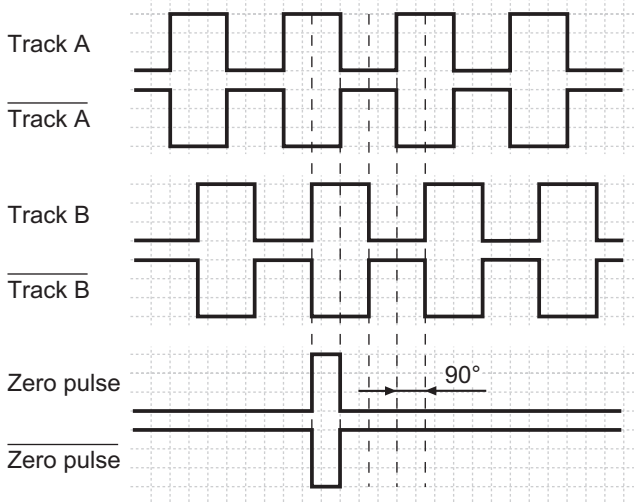

Optional: other reference impulse.

Incremental encoders

EX approval ATEX EEx d IIC T6
Resolution 5...5000 pulses

X 700 - incremental

Part number

X 700.I 1

See part number (pulses)

Connection

- 32 Cable 2 m, axial
- 34 Cable 5 m, axial

Voltage supply / signals

- 1 4.75...30 VDC / push-pull
- 2 5 VDC / RS422

Flange / Shaft

- 1 Clamping flange / $\varnothing 10$ mm IP 67

Terminal assignment

Core no.	Core colour	Assignment
#1	white	GND
#2	brown	UB
#3	green	Track A
#4	yellow	Track B
#5	grey	Track N
#6	pink	Track A inv.
#7	blue	Track B inv.
#8	red	Track N inv.

Trigger level

Outputs	Push-pull short-circuit proof
Output level High	>UB -1.4 V (I = -20 mA)
Output level Low	<0.5 V (I = 20 mA)
Load High / Low	<20 mA

Part number (pulses)

49 (5)	40 (60)	09 (250)	22 (1000)
36 (10)	41 (100)	13 (360)	23 (1024)
50 (25)	57 (128)	14 (400)	26 (1500)
39 (50)	06 (200)	15 (500)	28 (2000)

Other pulse numbers upon request.
Example: order key 23 = 1024 pulses.

Dimensions

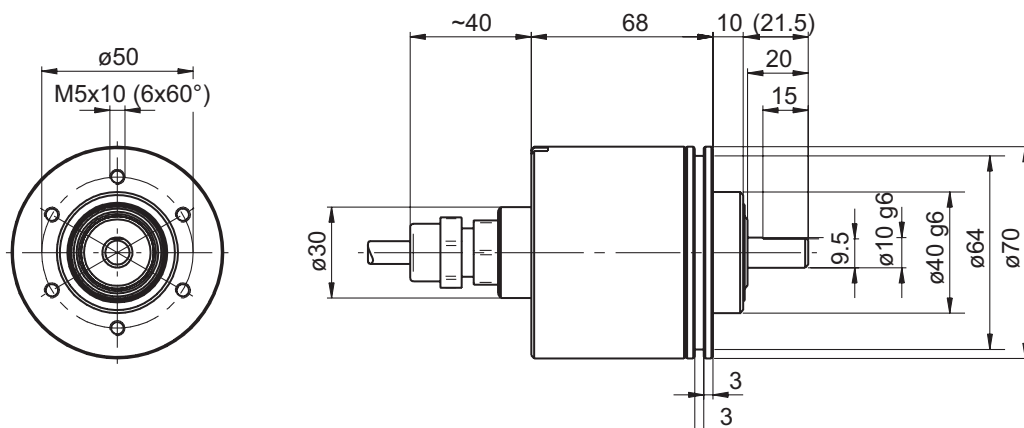

Incremental encoders

EX approval ATEX EEx d IIC T6

Resolution 5...5000 pulses

X 700 - incremental

Check list for EX-approval

In compliance with EU standards 94/9/EG for potentially explosive areas it is imperative that the present checklist is duly completed and that all pending questions relating to explosion protection and application are clarified.

Company: _____

Address: _____

Division: _____

In charge: _____

Phone: _____ Fax: _____

e-mail: _____

Product name:	Version:	Resolution (ppr / code):	Supply voltage:

Kind of e-connection:	Length of cable (m):	Output circuit:	Special options:

Responsibility

- Our customer will receive all relevant information to verify a correct application.
- Our customer has to clarify all relevant criterions and characteristics.
- The operator shall be responsible for not exceeding the maximum performance limits of our devices (see data sheet).

Device utilization/application (E.g.: Lacquering line, manufacturing tech., gas storing vessel etc.)

Device group, device category and zone classification

Device group	please tick
Device group I	<input type="checkbox"/>
Device group II	<input type="checkbox"/>

Category / Zone	Ex-atmosphere prevailing	
Category 1 (= Zone 0/20)	... permanently, long-term or frequently	<input type="checkbox"/>
Category 2 (= Zone 1/21)	... only now and then	<input type="checkbox"/>
Category 3 (= Zone 2/22)	... rarely or seldom	<input type="checkbox"/>

Zone classification		
G (gases)	Zone 0, zone 1, zone 2	<input type="checkbox"/>
D (dusts)	Zone 20, zone 21, zone 22	<input type="checkbox"/>

Check list for EX-approval

Ignition protection

please tick

Ex d	Flameproof (pressure-proof capsule)	<input type="checkbox"/>
Ex ia	Intrinsic safety	<input type="checkbox"/>
Ex ib	Intrinsic safety	<input type="checkbox"/>

Gas explosion group

Gases are classified into explosion groups. Danger increases from group II A to II C.

please tick

II A	Propane	<input type="checkbox"/>
II B	Ethylene	<input type="checkbox"/>
II C	Hydrogen, Acetylene	<input type="checkbox"/>

Temperature classes and groups of explosion

Temperature class	Max. surface temperature of operating equipment (°C)	Max. ignition temperature of combustible substances (°C)	please tick
T1	450	> 450	void
T2	300	>300...< 450	void
T3	200	>200...< 300	void
T4	135	>135...< 200	<input type="checkbox"/>
T5	100	>100...< 135	void
T6	85	> 85...< 100	<input type="checkbox"/>

Information on ambient and operating temperature

Expected operating temperature:	to be clarified
Field ambient temperature:	to be clarified

Mechanical strain

Rotation speed (rpm)	
Axial shaft load (N)	
Radial shaft load (N)	
Ambient impacts (salt, lye, etc.)	

Date _____ Signature _____

Stamp:

Date _____ Release EExB / trained sales _____