

Features

- CMOS Technology
- Drives Segment or Active Matrix Displays
- 16V to 47V Output Drive (V_{DD} to V_{EE})
- Selectable Output Shift Direction and Polarity
- 3 Output Switching Modes
- Cascadable (4 Maximum)

Applications

- eBooks / eReaders
- Electronic Shelf Labels / Point Of Purchase Displays
- Mobile Phones / Portable Hand Held Devices
- Smart Cards
- Signage

Ordering Information

Part	Description
MXEI2300WB	Gold Bumped Die / Wafer Form
MXEI2300XB	Gold Bumped Die / Waffle Pack



Description

The MXEI2300 is a 300-bit serial shift register, level translator, and high voltage buffered driver. The shift register is seeded by the CE1, CE2, R/L, SPV, and CKV inputs.

The output pulse pattern is selected with the MODE1 and MODE2 inputs. A one-pulse, continuous two-pulse, jumping two-pulse, or no-pulse pattern can be generated. Pulse polarity is selected with the WALK0 input.

The register output bits are amplified rail-rail from V_{EE} to V_{DD} , and the output strength of the buffer drivers is modulated by the V_{BIAS} generator. This allows the OGN outputs to be continuously optimized for peak performance while minimizing transients over a wide operating range.

The MXEI2300 is designed to operate over a temperature range of -40°C to $+85^{\circ}\text{C}$, and is available as Gold Bumped Die in Wafer Form or Waffle Pack.

Figure 1. Functional Block Diagram

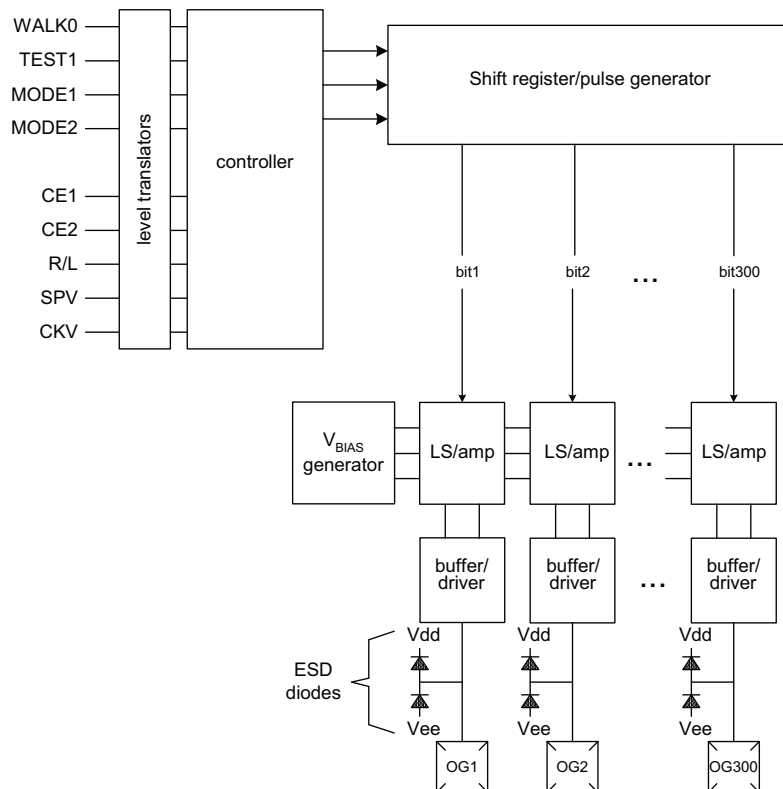

Click here to request a full data sheet

Clare provides its clients and potential customers with the best and most complete data and specifications possible, which might include proprietary information. Therefore, we require that the linked form be completed in order to request a comprehensive datasheet.

If you have special requests or if you don't see the data sheet you need, please feel free to ask in the Notes section of the form, or simply call us.

We do not share this information with anyone, and you will not receive unsolicited email.

For additional information please visit our website at: www.clare.com

Clare, Inc. makes no representations or warranties with respect to the accuracy or completeness of the contents of this publication and reserves the right to make changes to specifications and product descriptions at any time without notice. Neither circuit patent licenses nor indemnity are expressed or implied. Except as set forth in Clare's Standard Terms and Conditions of Sale, Clare, Inc. assumes no liability whatsoever, and disclaims any express or implied warranty, relating to its products including, but not limited to, the implied warranty of merchantability, fitness for a particular purpose, or infringement of any intellectual property right.

The products described in this document are not designed, intended, authorized or warranted for use as components in systems intended for surgical implant into the body, or in other applications intended to support or sustain life, or where malfunction of Clare's product may result in direct physical harm, injury, or death to a person or severe property or environmental damage. Clare, Inc. reserves the right to discontinue or make changes to its products at any time without notice.

Specification: DS-MXEI2300-8/6/09
©Copyright 2009, Clare, Inc.
All rights reserved. Printed in USA.
8/6/09