

400 mA, Dual Output LED Flash/PWM Dimming Lamp Driver

FEATURES

- 1-x and 2-x Charge Pump modes
- Supply voltage range from 2.7 to 5.5 V
- Low dropout PowerLite™ Current Regulator*
- Drives up to 2 LEDs at 200 mA simultaneously or one LED at 400 mA
- Power efficiency up to 90%
- Low current shutdown mode < 1 μ A
- Short circuit current limiting
- Thermal shutdown protection
- Available 8-pin 2 x 3 x 0.8 mm 8-pin TDFN package

APPLICATION

- White LED photoflash for digital cameras, cell phones, Smart Phones, and other portable devices

DESCRIPTION

TYPICAL APPLICATION CIRCUIT

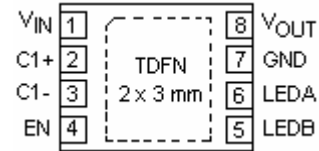

The LDS8641 is a high efficiency regulated charge pump with low dropout voltage that can drive two LEDs at 200 mA each simultaneously or one LED at 400 mA. Low dropout PowerLite™ Current Regulator (PCR) increases device's efficiency up to 90%.

The EN logic input functions as a chip enable.

The LEDs current is programmed at 200 mA for both channels in the factory. Please, consult factory about other current values. Each LED current can be programmed separately in the factory from 52 to 200 mA in 25 mA steps.

The regulated charge pump supports a wide input voltage range from 2.7 V to 5.5 V.

The device is available in 8-lead TDFN 2 mm x 3 mm package with a max height of 0.8 mm.

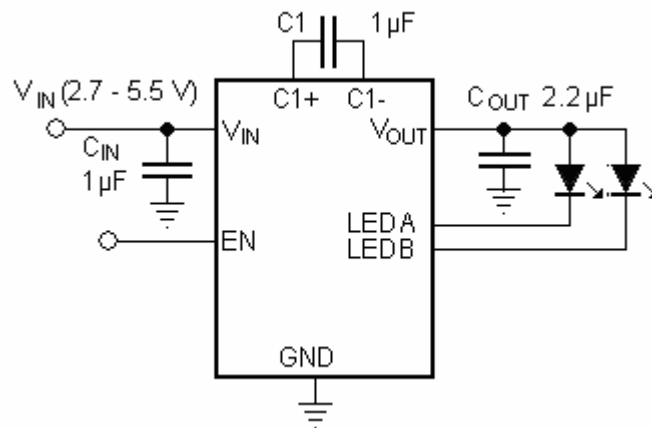

ABSOLUTE MAXIMUM RATINGS

Parameter	Rating	Unit
V _{IN} , LED _x , C1± voltage	6	V
V _{OUT} voltage	6	V
EN/SET voltage	V _{IN} + 0.7V	V
Storage Temperature Range	-65 to +160	°C
Junction Temperature Range	-40 to +125	°C
Soldering Temperature	300	°C

RECOMMENDED OPERATING CONDITIONS

Parameter	Rating	Unit
V _{IN}	2.7 to 5.5	V
Ambient Temperature Range	-40 to +85	°C

Typical application circuit with external components is shown on page 1.

ELECTRICAL OPERATING CHARACTERISTICS

(Over recommended operating conditions unless specified otherwise) V_{IN} = 3.6V, C1 = 2.2 μF, C_{in} = C_{out} = 1 μF, EN = High, T_{AMB} = 25°C

Name	Conditions	Min	Typ	Max	Units
Standby Current			0.6		mA
Shutdown Current	V _{EN} = 0V		0.5		μA
LED Current Accuracy	1mA ≤ I _{LED} ≤ 400 mA		±8		%
LED Channel Matching	(I _{LED} - I _{LEDAVG}) / I _{LEDAVG}		±8		%
Output Resistance (open loop) ¹	1-x mode		0.5		Ω
	2-x mode		1.7		
Charge Pump Frequency			1		MHz
Output short circuit Current Limit	V _{OUT} < 0.5V		2		A
Input Current Limit			2		A
1-x to 2-x Transition Thresholds at any LED pin	At 200 mA		150		mV
Transition Filter Delay			800		μs
EN/SET Pin	Input current	EN = 1.4 V, V _{IN} = 5.5 V		1	μA
	Logic Level	High		1.4	V
		Low			
Thermal Shutdown ¹			160		°C
Thermal Hysteresis ¹			25		
Under Voltage Lockout (UVLO)			2.3		V
Output Over Voltage protection		5.6		5.9	V
Flash LED Turn-on Time ²	1-x mode		100		μs
	2-x mode		1.2		ms
PWM Frequency ³		0.1		1	kHz

- Note:
1. Sample test only
 2. Measured from EN LOW to HIGH transition to I_{LED} current reaches 90% of regulated level
 3. See Current setting Error vs. Duty Cycle and PWM Frequency at p.3

TYPICAL CHARACTERISTICS

$V_{IN} = 3.6V$, $I_{OUT} = 400\text{ mA}$ (2 LEDs at 200mA), $C_{IN} = C1 = 1\mu F$, $C_{OUT} = 2\mu F$, $T_{AMB} = 25^\circ C$ unless otherwise specified

Power-Up in 1-x mode



$V_{IN} = 4.2\text{ V}$, Ch1 – PWM, Ch2 – LED current (200 mA/div), Ch3 – Output voltage

Power-Up in 2-x Mode



$V_{IN} = 3.6\text{ V}$, Ch1 – PWM, Ch2 – LED current (200 mA/div), Ch3 – Output voltage

Operating Waveforms at 1kHz PWM mode 10% Duty Cycle



$V_{IN} = 4.2\text{ V}$, Ch1 – PWM, Ch2 – LED current (200 mA/div)

Operating Waveforms at 1kHz PWM mode 90% Duty Cycle



$V_{IN} = 4.2\text{ V}$, Ch1 – PWM, Ch2 – LED current (200 mA/div)

LED Current Setting Error vs. Duty Cycle

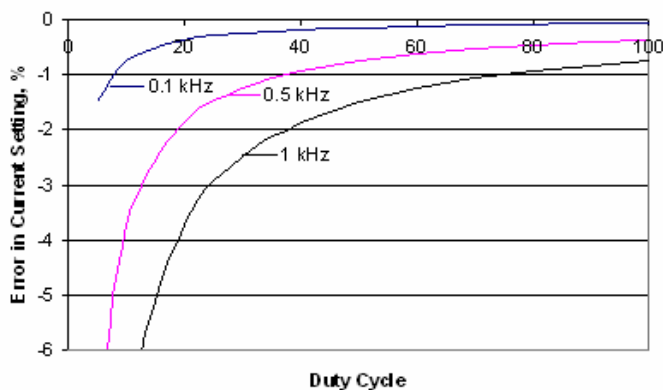

Power-Down Delay (1-x Mode)

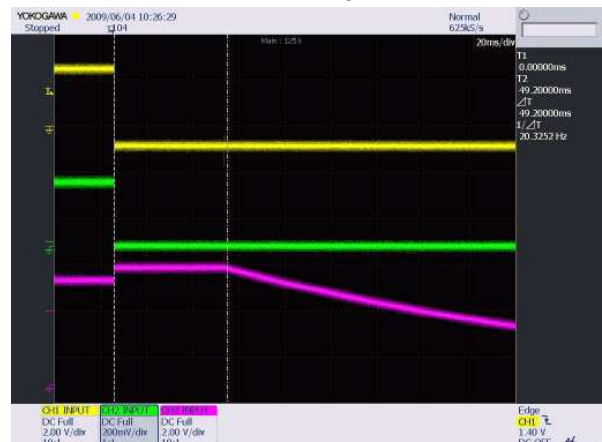

$V_{IN} = 4.2\text{ V}$, Ch1 – PWM, Ch2 – LED current (200 mA/div)

PIN DESCRIPTION

Pin #	Name	Function
1	V _{IN}	Charge pump input, connect to battery or supply
2	C1+	Flying capacitor 1 Positive terminal
3	C1-	Flying capacitor 1 Negative terminal
4	EN	Device enable (active high)
5	LEDB	LEDB cathode terminal
6	LEDA	LEDA cathode terminal
7	GND	Ground Reference
8	V _{OUT}	Charge pump output connected to the LED anodes
PAD	PAD	Connect to GND on the PCB

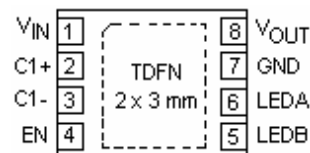

Top view: TDFN 8-lead 2 X 3 mm

PIN FUNCTION

V_{IN} is the supply pin for the charge pump. A small 1 μ F ceramic bypass capacitor is required between the V_{IN} pin and ground near the device. The operating input voltage range is from 2.7 V to 5.5 V. If V_{IN} falls below the under-voltage threshold, all LED channels disable and the device enters shutdown mode.

EN is the enable control logic input for all LED channels. Guaranteed levels of logic high and logic low are set at 1.4 V and 0.4 V respectively. To place the device into zero current mode, the EN pin must be held low for more than 50 ms.

V_{OUT} is the charge pump output that is connected to the LED anodes. A small 2.2 μ F ceramic bypass capacitor is required between the V_{OUT} pin and ground near the device.

GND is the ground reference for the charge pump. The pin must be connected to the ground plane on the PCB.

C1+, C1- are connected to each side of the ceramic flying capacitor C1 = 1 μ F

LEDA, LEDB provides the internal regulated current source for each of the LED cathodes. These pins enter high-impedance zero current state whenever the device is in shutdown mode. These pins may be teed together to provide sum of the currents set at every channel.

PAD is the exposed pad underneath the package. For best thermal performance, the pad should be soldered to the PCB and connected to the ground plane

BLOCK DIAGRAM

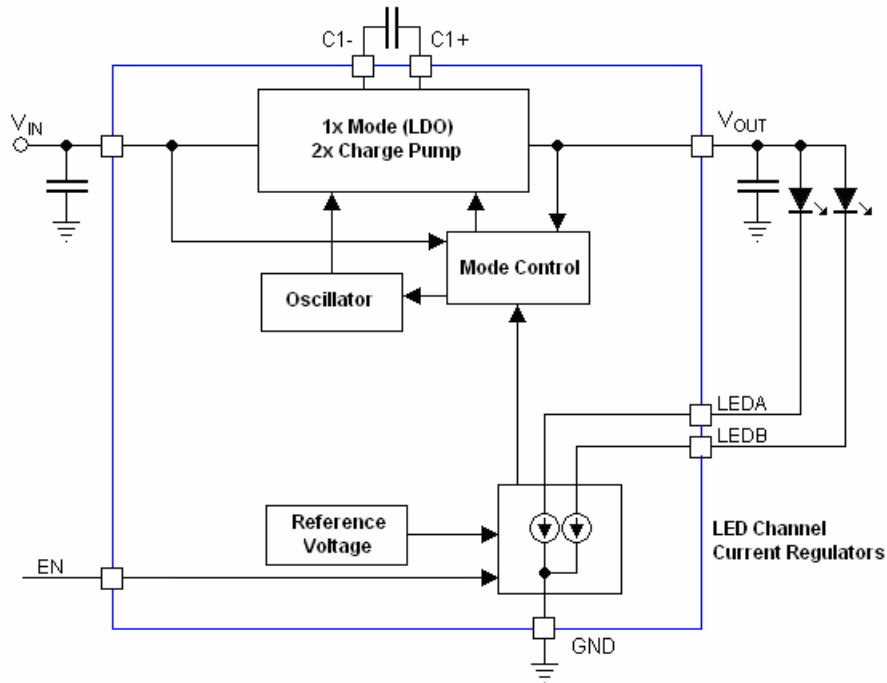

Figure 2. LDS8641 Functional Block Diagram

BASIC OPERATION

LDS8641 is a charge pump designed for converting at Li-Ion battery voltage to drive a white LED used in photo flash applications. The LEDs current is factory programmed at 200 mA for both channels. Consult factory about other current values. Every LED may be factory programmed separately in the range from 25 to 200 mA in 25 mA steps.

The LDS8641 is in standby mode after applying V_{IN} voltage until logic HIGH level is applied to EN pin. The device requires approximately 100 μ s to wake up.

Device starts operating with soft-start at 1-x mode to minimize inrush current

At 1-x mode, the V_{OUT} is approximately equal to V_{IN} (less any internal voltage losses). If the output voltage is sufficient to regulate all LED currents, the device remains in 1-x operating mode.

The charge pump has two modes of operation: 1-X, and 2-x. The device changes modes if the output voltage drops below the minimum needed to support the desired I_{LED} current.

The low dropout PowerLite™ Current regulator (PCR) performs well at input voltages up to 150 mV above LED forward voltage V_F significantly increasing driver's efficiency. The LDS8641 monitors voltage

drop V_d across PCR at every channel in ON state. If this voltage falls below 150 mV (typical) at any one channel, (channel with LED with highest forward voltage), the Mode Control Block changes charge pump mode to the next multiplication ratio.

$V_d (LED_{A/B}) = V_{IN} \times M - V_F - R_{cp} \times I_{OUT}$, where R_{cp} is a Charge Pump Output Resistance at given mode, I_{OUT} is sum of all LED currents, and M is a charge pump' multiplication ratio.

If the input voltage is insufficient or falls to a level where $V_d \leq 150$ mV, and the regulated currents cannot be maintained, the low dropout PowerLite™ Current Regulator switches the charge pump into 2-x mode (after a fixed delay time of about 800 μ s). In 2-x mode, the charge pump' output voltage is approximately equal to 2 times the input supply voltage (less any internal voltage losses).

LED Current Setting

The current in each of the two LED channels is factory programmed; however, average current value may be decreased using PWM pulses. Check LED Data sheet to avoid LED thermal damage at high current.

Unused LED Channels

For applications with only one LED, unused channel can be connected to V_{OUT} or both channels may be teed together to provide sum of the currents set at each channel.

Protection Modes

The LDS8641 has follow protection modes:

1. LED short to V_{OUT} protection

If LED pin is shorted to V_{OUT} , LED burned out becomes as short circuit, or LED pin voltage is within from V_{OUT} to $(V_{OUT} - 1.5V)$ range, LDS8641 recognizes this condition as “LED Short” and disables this channel. If LED pin voltage is less than $(V_{out} - 1.5V)$, LDS8641 restores LED current at this particular channel to programmed value.

2. V_{OUT} Over-Voltage Protection

The charge pump’ output voltage V_{OUT} automatically limits at about 5.9 V maximum. This is to prevent the output pin from exceeding its absolute maximum rating.

3. V_{OUT} Short Circuit Protection

If V_{OUT} is shorted to ground before LDS8641 is enabled, input current may increase up to 1 A within 20 μs after enable and is limited to ~ 90 mA after that.

4. Over-Temperature Protection

If the die temperature exceeds $+160^{\circ}C$, the driver will enter shutdown mode. Device restores normal operation after die temperature falls below $135^{\circ}C$.

5. Input Voltage Under-Voltage Lockout

If V_{IN} falls below 2.3 V but above 1.7 V (typical value), LDS8641 will restart when input voltage rises above 2.3 V called lockout mode. If V_{IN} continues fall below 1.7 V, LDS8641 device will enter shutdown mode.. To restart device, set EN pin logic low for more than 50 ms and logic high after that..

6. Open LED Definition

When LED becomes an open circuit, device will enter into 2-x mode unless this unused LED channel is connected to V_{OUT} directly.

LED Selection

If the power source is a Li-ion battery, LEDs with lowest forward voltages are recommended to achieve highest efficiency and extended operation on a single battery charge.

LEDs with forward voltages (V_F) ranging from 1.6 V to 4 V may be used. Charge pump operates in highest efficiency when V_F voltage is close to V_{IN} voltage multiplied by switching mode, i.e. $V_{IN} \times 1$ or $V_{IN} \times 2$

External Components

The driver requires three external ceramic capacitors (C_1 , C_{IN} , and C_{OUT}) X5R or X7R type. In 2-x charge pump mode, an input bypass capacitor of $1\mu F$ is sufficient.

In 1x mode, the device operates in linear mode and does not introduce switching noise back onto the supply.

Recommended Layout

In charge pump mode, the driver switches internally at a high frequency. It is recommended to minimize trace length to all capacitors. A ground plane should cover the area under the driver IC as well as the bypass capacitors. Short connection to ground on capacitors C_{IN} and C_{OUT} can be implemented with the use of multiple via. A copper area matching the TDFN exposed pad (PAD) must be connected to the ground plane underneath. The use of multiple via improves the package heat dissipation (see figure below).

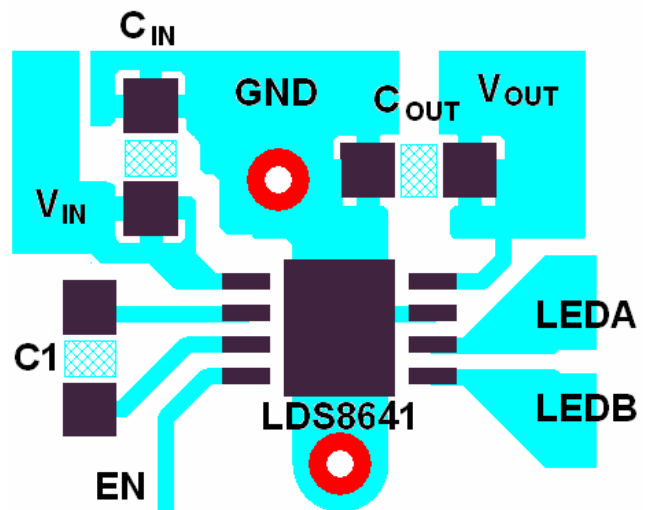

The ground plane on the top layer is connected to the ground plane on the bottom layer through two vias to improve power dissipation.

PACKAGE DRAWING AND DIMENSIONS

8-PIN TDFN (HV3), 2mm x 3mm, 0.5mm PITCH

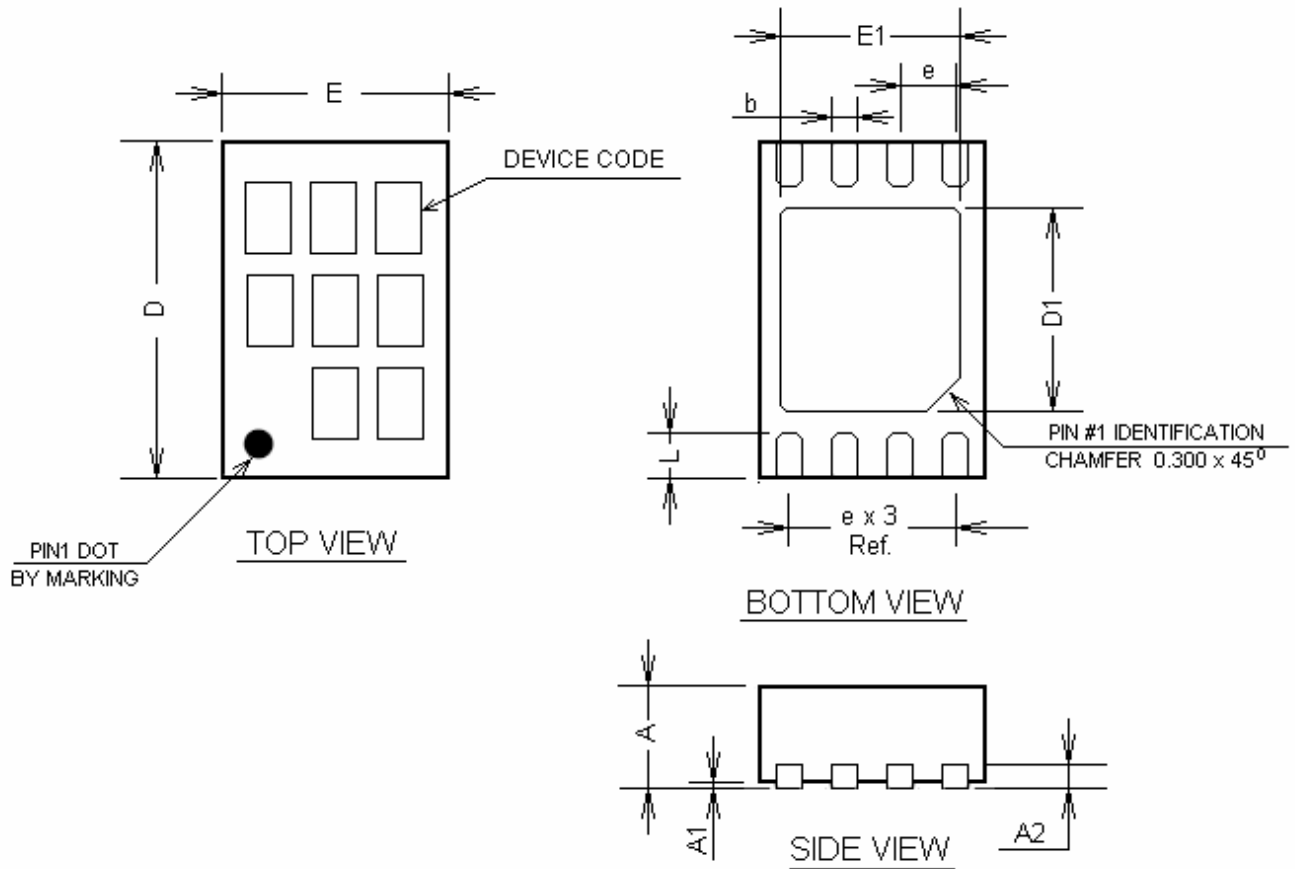

SYMBOL	MIN	NOM	MAX
A	0.700	0.750	0.800
A1	-	0.000	0.050
A2		0.203 Ref.	
b	0.180	0.230	0.280
D	2.950	3.000	3.050
D1	1.750	1.800	1.850
E	1.950	2.000	2.050
E1	1.550	1.600	1.650
e		0.500 Bsc	
L	0.350	0.400	0.450

Note:

1. All dimensions are in millimeters
2. Complies with JEDEC Standard MO-220

ORDERING INFORMATION

Part Number	Package	Package Marking
LDS8641 008-T2 ¹⁾	TDFN-8 2 x 3mm ²⁾	641

Notes:

1. Quantity per reel is 2000
2. Matte-Tin Plated Finish (RoHS-compliant)

EXAMPLE OF ORDERING INFORMATION

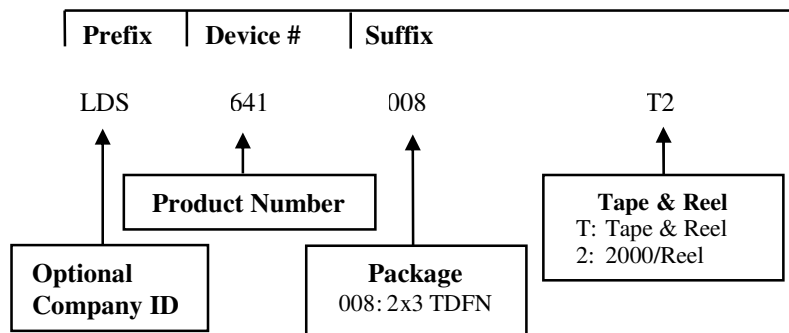

Notes:

- 1) All packages are RoHS-compliant (Lead-free, Halogen-free).
- 2) The standard lead finish is Matte-Tin.
- 3) The device used in the above example is a LDS8641 008-T2 (2x3 TDFN, Tape & Reel).
- 4) For additional package and temperature options, please contact your nearest IXYS Corp. Sales office.

Warranty and Use

IXYS CORP. MAKES NO WARRANTY, REPRESENTATION OR GUARANTEE, EXPRESS OR IMPLIED, REGARDING THE SUITABILITY OF ITS PRODUCTS FOR ANY PARTICULAR PURPOSE, NOR THAT THE USE OF ITS PRODUCTS WILL NOT INFRINGE ITS INTELLECTUAL PROPERTY RIGHTS OR THE RIGHTS OF THIRD PARTIES WITH RESPECT TO ANY PARTICULAR USE OR APPLICATION AND SPECIFICALLY DISCLAIMS ANY AND ALL LIABILITY ARISING OUT OF ANY SUCH USE OR APPLICATION, INCLUDING BUT NOT LIMITED TO, CONSEQUENTIAL OR INCIDENTAL DAMAGES.

IXYS Corp. products are not designed, intended, or authorized for use as components in systems intended for surgical implant into the body, or other applications intended to support or sustain life, or for any other application in which the failure of the IXYS Corp. product could create a situation where personal injury or death may occur.

IXYS Corp. reserves the right to make changes to or discontinue any product or service described herein without notice. Products with data sheets labeled "Advance Information" or "Preliminary" and other products described herein may not be in production or offered for sale.

IXYS Corp. advises customers to obtain the current version of the relevant product information before placing orders. Circuit diagrams illustrate typical semiconductor applications and may not be complete.



IXYS Corp.
1590 Buckeye Dr.,
Milpitas, CA 95035-7418
Phone: 408.457.9000
Fax: 408.496.0222
<http://www.ixys.com>

Document No: 8641_DS
Revision: N1.0
Issue date: 2/8/2011