

400 mA White LED Driver for Photo Flash

FEATURES

- 1-x and 2-x Charge pump modes
- Low dropout PowerLite™ Current Regulator*
- Drives up to 2 LEDs at 200 mA simultaneously or one LED at 400 mA
- Smart OneWire™ LED current programming and PWM mode LED current control
- Power efficiency up to 90%
- Low current shutdown mode < 1 μ A
- Short circuit current limiting
- Thermal shutdown protection
- Timeout to protect LED at high currents
- 8-pin 2 x 3 x 0.8 mm TDFN package

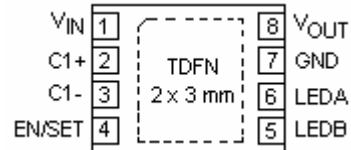

Inclusion of a low dropout PowerLite™ Current Regulator (PCR) increases device's efficiency up to 90%.

The EN/SET logic input functions as a chip enable and a current setting interface.

The LEDs current is programmable by Smart OneWire™ digital interface in 32 steps from 52 to 200 mA. Every LED may be turned on/off or programmed separately

Low noise input ripple is achieved by operating at a constant switching frequency, which allows the use of small external ceramic capacitors. The charge pump supports a range of input voltages from 2.7 V to 5.5 V.

The device is available in 8-lead TDFN 2 mm x 3 mm package with a max height of 0.8 mm.

APPLICATION

- Photo flash plus red eyes reduction
- White LED photoflash for cell phones and still cameras

DESCRIPTION

The LDS8640 is a high efficiency charge pump with low dropout voltage that can drive two LEDs at 200 mA each simultaneously or one LED at 400 mA.

TYPICAL APPLICATION CIRCUIT

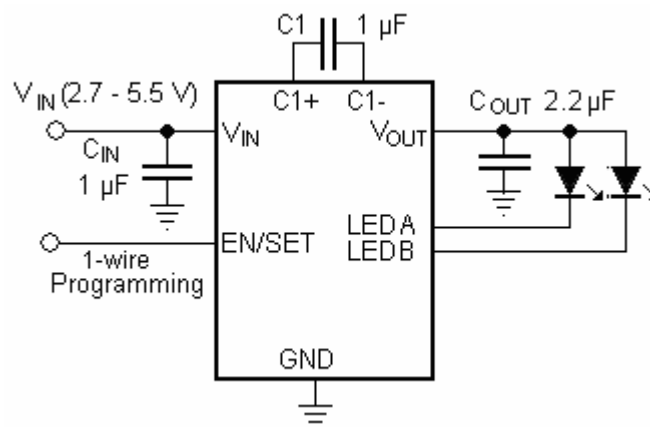

ABSOLUTE MAXIMUM RATINGS

Parameter	Rating	Unit
V _{IN} , LED _x , C1± voltage	6	V
V _{OUT} voltage	6	V
EN/SET voltage	V _{IN} + 0.7V	V
Storage Temperature Range	-65 to +160	°C
Junction Temperature Range	-40 to +125	°C
Soldering Temperature	300	°C

RECOMMENDED OPERATING CONDITIONS

Parameter	Rating	Unit
V _{IN}	2.7 to 5.5	V
Ambient Temperature Range	-40 to +85	°C

Typical application circuit with external components is shown on page 1.

ELECTRICAL OPERATING CHARACTERISTICS

(Over recommended operating conditions unless specified otherwise) V_{IN} = 3.6V, C1 = 2.2 μF, C_{in} = C_{out} = 1 μF, EN = High, T_{AMB} = 25°C

Name	Conditions	Min	Typ	Max	Units
Standby Current			0.6		mA
Shutdown Current	V _{EN} = 0V		0.5		μA
LED Current Accuracy	1mA ≤ I _{LED} ≤ 400 mA		±8		%
LED Channel Matching	(I _{LED} - I _{LEDAVG}) / I _{LEDAVG}		±8		%
Output Resistance (open loop) ¹	1-x mode		0.5		Ω
	2-x mode		1.7		
Charge Pump Frequency			1		MHz
Output short circuit Current Limit	V _{OUT} < 0.5V		2		A
Input Current Limit			2		A
1-x to 2-x Transition Thresholds at any LED pin	At 200 mA		150		mV
Transition Filter Delay			800		μs
EN/SET Pin	Input current	EN = V _{IN} = 5.5 V	1		μA
	Logic Level	High	1.4		V
		Low			
Thermal Shutdown ¹			160		°C
Thermal Hysteresis ¹			25		
Under Voltage Lockout (UVLO)			2.3		V
Output Over Voltage protection		5.6		5.9	V
Flash LED Safety Timer			250		ms

Note: 1. Sample test only
2. Measured from Flash LED ON command to I_{LED} reaches 90% of regulated level

RECOMMENDED EN/SET TIMING

For $2.7 \leq V_{IN} \leq 5.5V$, over full ambient temperature range -40 to $+85^{\circ}C$.

Symbol	Name	Conditions	Min	Typ	Max	Units
$t_{SETUP-PWM}$	EN/SET setup from shutdown in PWM mode		10	100	200	μs
$t_{SETUP-COM}$	EN/SET setup from shutdown in command mode		300	400	2000	μs
t_{B0}	Bit "zero" positive pulse		1	2	4	μs
t_{B1}	Bit "one" positive pulse		8	16	200	μs
t_{CLO1}	Low time between 16 command pulses		2	25	50	μs
t_{CLO2}	Low time between two 16-byte command sets		100		200	μs
t_{LO}	EN LOW Time to finalize command mode		0.3		30	ms
t_{OFF}	EN/SET low time to shutdown		50			ms

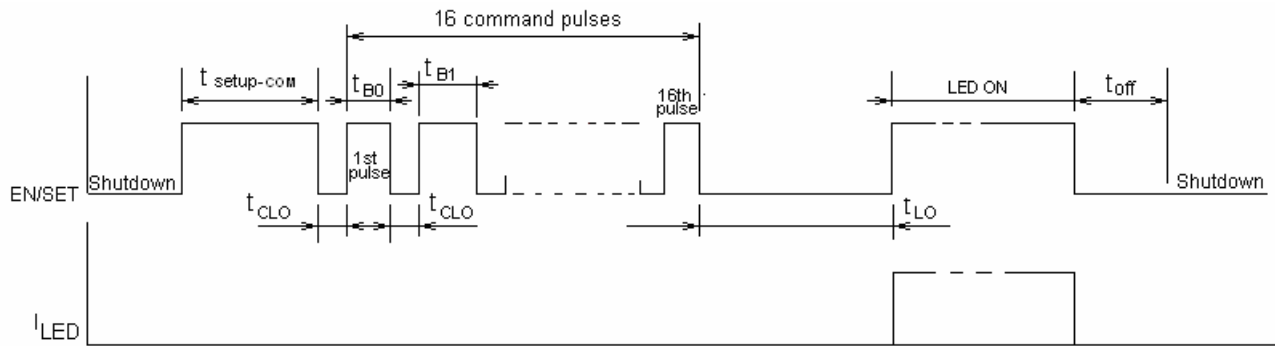

Fig. 1 Command mode programming

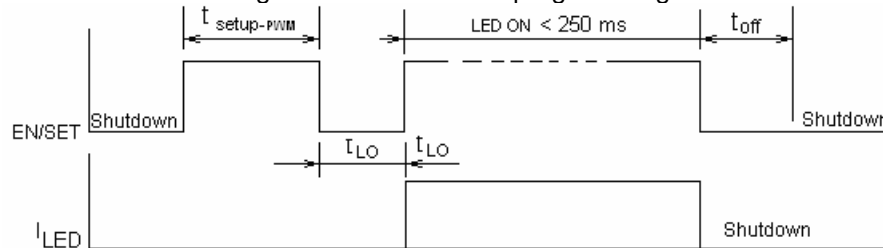

Fig. 2 PWM mode with short pulse

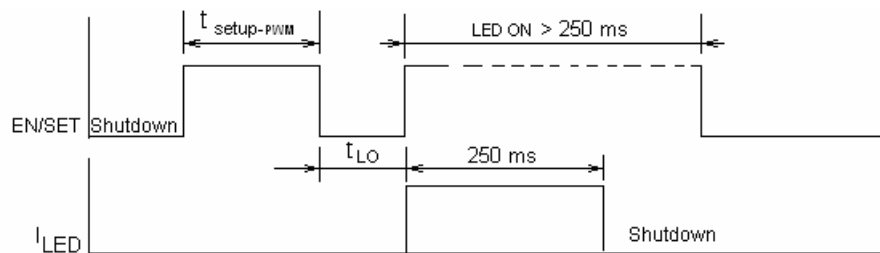

Fig. 3 PWM mode with long pulse

LED CURRENT SETTING COMMANDS

Command Value		Command Description
Binary	Hex	
0000 0000 0000 0001	00 01	Turn LEDA "ON" with LED current at factory preset maximum value, Safety Timer is "ON"
0000 0000 0000 0010	00 02	Turn LEDB "ON" with LED current at factory preset maximum value, Safety Timer is "ON"
0000 0000 0000 0011	00 03	Turn LEDA and LEDB "ON" with LED current at factory preset maximum value, Safety Timer is "ON"
0000 0100 000Y YYYY	04 ZZ	<p>Turn LEDA "ON" with LED current other than factory programmed value. Binary code Y YYYY is determined as desired LED current value in mA divided by 25.6 mA minus 1. Safety Timer is "ON"</p> <p>Example: Binary Code to set 540 mA current is equal $(540/25.6 - 1) = 20$ (dec) = 1 0100 (bin) = 14 (hex) Because LSB value is 25.6 mA, LED current can be set with this resolution only.</p>
0000 0110 000Y YYYY 0000 0010 0000 0001	06 ZZ 02 01	Set of two commands to program LEDA current as above, but Safety Timer is "OFF"
0000 1000 0000 YYYY	08 0Z	<p>Turn LEDB "ON" with LED current other than factory programmed value. Binary code YYYY is determined as desired LED current value in mA divided by 25.6 mA minus 1. Safety Timer is "ON"</p> <p>Example: Binary Code to set 307 mA current is equal $(307/25.6 - 1) = 11$ (dec) = 1011 (bin) = B (hex) Because LSB value is 25.6 mA, LED current can be set with this resolution only.</p>
0000 1010 0000 YYYY 0000 0010 0000 0010	0A 0Z 02 02	Set of two commands to program LEDB current as above, but Safety Timer is "OFF"

TYPICAL CHARACTERISTICS

$V_{IN} = 3.6V$, $I_{OUT} = 400\text{ mA}$ (2 LEDs at 200mA), $C_{IN} = C_1 = 1\mu F$, $C_{OUT} = 2\mu F$, $T_{AMB} = 25^\circ C$ unless otherwise specified

Power-Up in 1-x mode



$V_{IN} = 4.2\text{ V}$, Ch1 – EN/SET, Ch2 – LED current (200 mA/div), Ch3 – Output voltage

Power-Up in 2-x Mode



$V_{IN} = 3.6\text{ V}$, Ch1 – EN/SET, Ch2 – LED current (200 mA/div), Ch3 – Output voltage

Operating Waveforms at 1kHz PWM mode 10% Duty Cycle

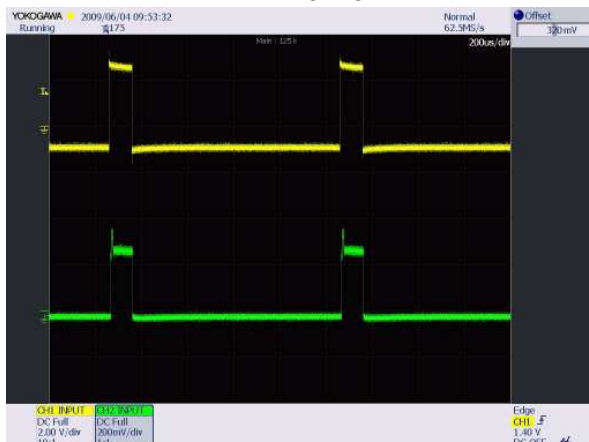

$V_{IN} = 4.2\text{ V}$, Ch1 – EN/SET, Ch2 – LED current (200 mA/div)

Operating Waveforms at 1kHz PWM mode 90% Duty Cycle



$V_{IN} = 4.2\text{ V}$, Ch1 – EN/SET, Ch2 – LED current (200 mA/div)

LED Current Setting Error vs. Duty Cycle in PWM Mode

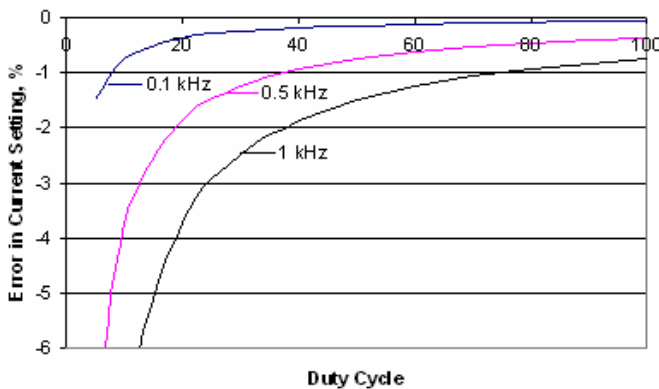

Power-Down Delay (1-x Mode)

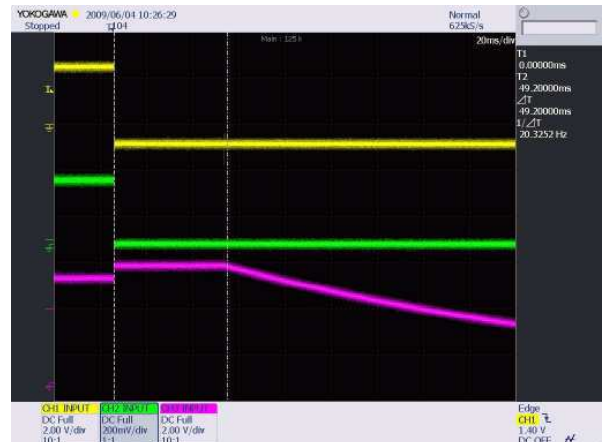

$V_{IN} = 4.2\text{ V}$, Ch1 – PWM, Ch2 – LED current (200 mA/div)

PIN DESCRIPTION

Pin #	Name	Function
1	V _{IN}	Charge pump input, connect to battery or supply
2	C1+	Flying capacitor 1 Positive terminal
3	C1-	Flying capacitor 1 Negative terminal
4	EN/SET	Device enable (active high) and Dimming Control
5	LEDB	LEDB cathode terminal
6	LEDA	LEDA cathode terminal
7	GND	Ground Reference
8	V _{OUT}	Charge pump output connected to the LED anodes
PAD	PAD	Connect to GND on the PCB

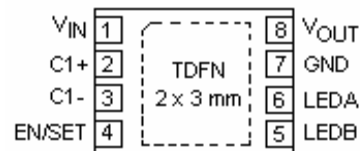

Top view: TDFN 8-lead 2 X 3 mm

PIN FUNCTION

V_{IN} is the supply pin for the charge pump. A small 1 μ F ceramic bypass capacitor is required between the V_{IN} pin and ground near the device. The operating input voltage range is from 2.7 V to 5.5 V. If V_{IN} falls below the under-voltage threshold, all LED channels disable and the device enters shutdown mode.

EN/SET is the enable and one wire addressable control logic input for all LED channels. Guaranteed levels of logic high and logic low are set at 1.4 V and 0.4 V respectively. When EN/SET is initially taken high, the device becomes enabled and all LED currents remain at 0mA. To start LED current, device should be in PWM mode (See p. 5). To place the device into zero current mode, the EN/SET pin must be held low for more than 50 ms.

V_{OUT} is the charge pump output that is connected to the LED anodes. A small 2.2 μ F ceramic bypass capacitor is required between the V_{OUT} pin and ground near the device.

GND is the ground reference for the charge pump. The pin must be connected to the ground plane on the PCB.

C1+, C1- are connected to each side of the ceramic flying capacitor C1

LEDA, LEDB provides the internal regulated current source for each of the LED cathodes. These pins enter high-impedance zero current state whenever the device is in shutdown mode.

PAD is the exposed pad underneath the package. For best thermal performance, the pad should be soldered to the PCB and connected to the ground plane

BLOCK DIAGRAM

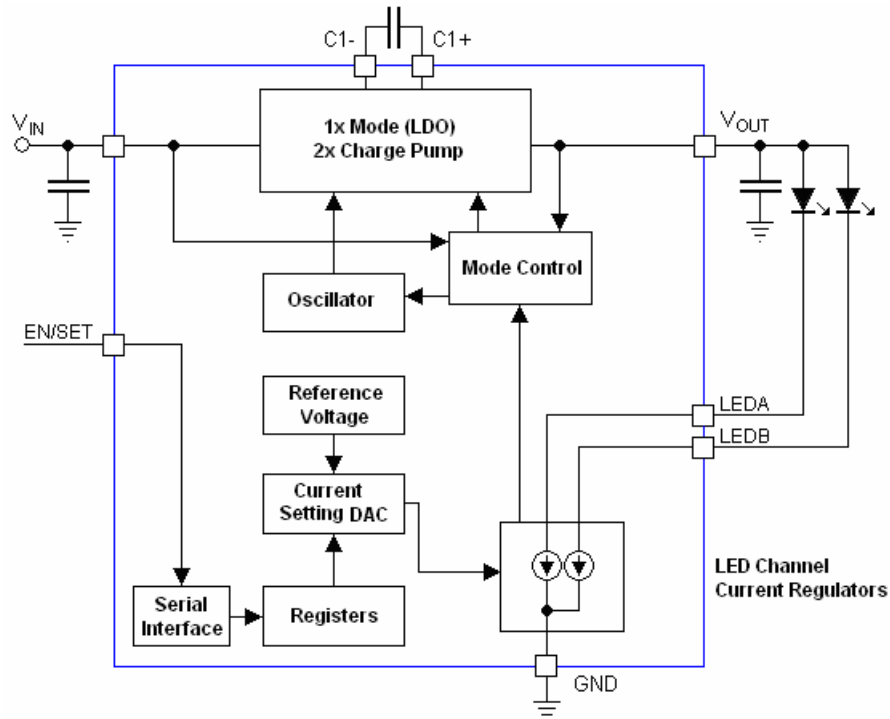

Figure 2. LDS8640 Functional Block Diagram

BASIC OPERATION

LDS8640 is a charge pump designed for converting at Li-Ion battery voltage to drive a white LED used in photo flash applications. The output current has a maximum value of 200 mA/per channel if one LED is used or 400 mA/per channel if both LEDs are used simultaneously. The output current is programmable via the Smart OneWire™ interface signaled at the EN pin.

The LDS8640 is in standby mode after applying V_{IN} voltage until logic HIGH level is applied to EN pin. The device requires approximately 50 μ s to wake up.

The LDS8640 may operate in either PWM or command mode.

PWM mode starts if first pulse applied to EN pin after power-up is shorter than or equal $t_{SETUP-PWM}$. At this mode, second and every next pulse applied to EN pin recognizes as PWM pulse, both LEDA and LEDB channels are on, and maximum LED current is equal factory preset value.

The command mode starts if first pulse applied to EN pin after power-up is longer than or equal $t_{SETUP-COM}$. At this mode, every next 16 pulses applied to EN

pin recognizes as command, both LEDA and LEDB channels are off, and no current is flowing through LEDs. Command mode is used to set other than factory preset LED current value, turn on/off one of the channels, or turn off timeout protection. After command provided, device goes into PWM mode with maximum current value and number of channels in ON state in respect to command provided. EN pin should be logic LOW for more than t_{LO} to finalize command mode

Device starts operating with soft-start at 1-x mode to minimize inrush current

At 1-x mode, the V_{OUT} is approximately equal to V_{IN} (less any internal voltage losses). If the output voltage is sufficient to regulate all LED currents, the device remains in 1-x operating mode.

The charge pump has two modes of operation: 1-x, and 2-x. The device changes modes if the output voltage drops below the minimum needed to support the desired I_{LED} current.

The low dropout PowerLite™ Current regulator (PCR) performs well at input voltages up to 150 mV above LED forward voltage V_F significantly increasing driver's efficiency. The LDS8640 monitors voltage

drop V_d across PCR at every channel in ON state. If this voltage falls below 150 mV (typical) at any one channel, (channel with LED with highest forward voltage), the Mode Control Block changes charge pump mode to the next multiplication ratio.

V_d (LEDA/B) = $V_{IN} \times M - V_F - R_{cp} \times I_{OUT}$, where R_{cp} is a Charge Pump Output Resistance at given mode, I_{OUT} is sum of all LED currents, and M is a charge pump' multiplication ratio.

If the input voltage is insufficient or falls to a level where $V_d \leq 150$ mV, and the regulated currents cannot be maintained, the low dropout PowerLite™ Current Regulator switches the charge pump into 2-x mode (after a fixed delay time of about 800 μ s). In 2-x mode, the charge pump' output voltage is approximately equal to 2 times the input supply voltage (less any internal voltage losses).

LED Current Setting

The current in each of the two LED channels is programmable through the Smart OneWire™ EN/SET digital control input. By pulsing this signal according to a shown above protocol, a set of internal registers can be addressed and written into allowing to configure each of LEDs with the desired current. See recommended commands at the Table "LED CURRENT SETTING COMMANDS"

Unused LED Channels

For applications with only one LED, unused LED can be disabled via the register internally and connect to V_{OUT} .

Protection Modes

The LDS8640 has follow protection modes:

1. LED short to V_{OUT} protection

If LED pin is shorted to V_{OUT} , LED burned out becomes as short circuit, or LED pin voltage is within from V_{OUT} to ($V_{OUT} - 1.5V$) range, LDS8640 recognizes this condition as "LED Short" and disables this channel. If LED pin voltage is less than ($V_{out} - 1.5V$), LDS8640 restores LED current at this particular channel to programmed value.

2. V_{OUT} Over-Voltage Protection

The charge pump' output voltage V_{OUT} automatically limits at about 6.2 V maximum. This is to prevent the output pin from exceeding its absolute maximum rating.

3. V_{OUT} Short Circuit Protection

If V_{OUT} is shorted to ground before LDS8640 is enabled, input current may increase up to 1 A within

20 μ s after enable and is limited to ~ 90 mA after that.

4. Over-Temperature Protection

If the die temperature exceeds +160°C, the driver will enter shutdown mode. Device restores normal operation after die temperature falls below 135°C.

5. Input Voltage Under-Voltage Lockout

If V_{IN} falls below 2.3 V but above 1.7 V (typical value), LDS8640 will restart when input voltage rises above 2.3 V called lockout mode. If V_{IN} continues fall below 1.7 V, LDS8640 device will enter shutdown mode and reset all data register. To restart device, set EN/SET pin logic low for more than 50 ms and program new I_{LED} current value using Smart OneWire™ interface.

6. Open LED Definition

When LED becomes an open circuit, device will enter into 2-x mode. Unless this unused LED channel was disabled via Smart OneWire™ commands.

7. LED protection

LDS8640 uses timeout ~ 250 ms to protect LEDs from thermal damage at currents above 200 mA. This function may be disabled in command mode.

LED Selection

If the power source is a Li-ion battery, LEDs with lowest forward voltages are recommended to achieve highest efficiency and extended operation on a single battery charge.

LEDs with forward voltages (V_F) ranging from 1.6 V to 4 V may be used. Charge pump operates in highest efficiency when V_F voltage is close to V_{IN} voltage multiplied by switching mode, i.e. $V_{IN} \times 1$ or $V_{IN} \times 2$

External Components

The driver requires three external ceramic capacitors (C_1 , C_{IN} , and C_{OUT}) X5R or X7R type. In 2-x charge pump mode, the input current ripple is very low, and an input bypass capacitor of 1 μ F is sufficient.

In 1-x mode, the device operates in linear mode and does not introduce switching noise back onto the supply.

Recommended Layout

In charge pump mode, the driver switches internally at a high frequency. It is recommended to minimize trace length to all capacitors. A ground plane should cover the area under the driver IC as well as the bypass capacitors. Short connection to ground on capacitors C_{IN} and C_{OUT} can be implemented with the use of multiple via. A copper area matching the TDFN exposed pad (PAD) must be connected to the

LDS8640

ground plane underneath. The use of multiple via improves the package heat dissipation.

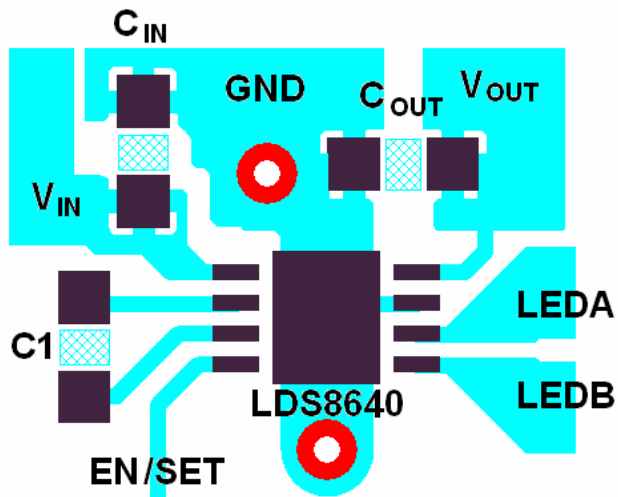

PACKAGE DRAWING AND DIMENSIONS

8-PIN TDFN (HV3), 2mm x 3mm, 0.5mm PITCH

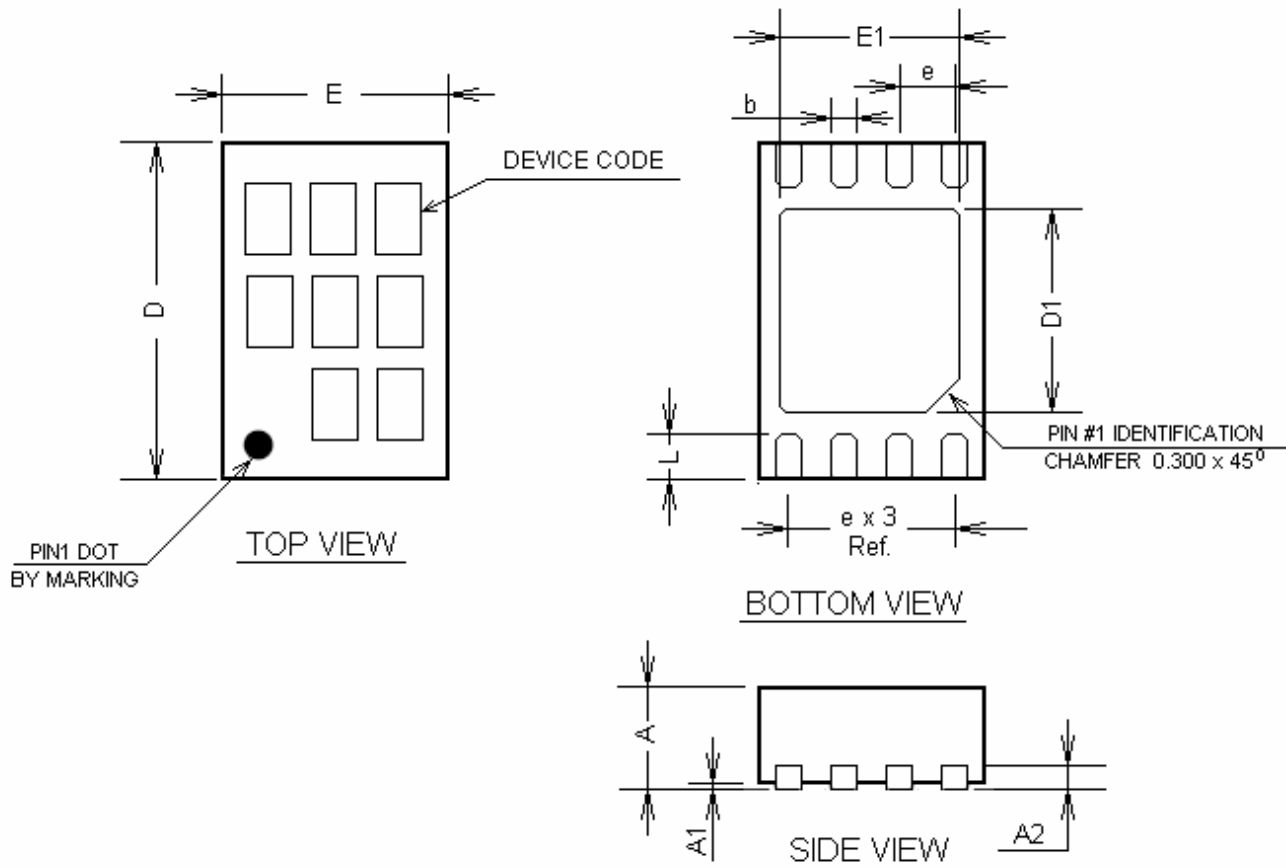

SYMBOL	MIN	NOM	MAX
A	0.700	0.750	0.800
A1	-	0.000	0.050
A2		0.203 Ref.	
b	0.180	0.230	0.280
D	2.950	3.000	3.050
D1	1.750	1.800	1.850
E	1.950	2.000	2.050
E1	1.550	1.600	1.650
e		0.500 Bsc	
L	0.350	0.400	0.450

Note:

1. All dimensions are in millimeters
2. Complies with JEDEC Standard MO-220

ORDERING INFORMATION

Part Number	Package	Package Marking
LDS8640 008-T2 ¹⁾	TDFN-8 2 x 3mm ²⁾	640

Notes:

1. Quantity per reel is 2000
2. Matte-Tin Plated Finish (RoHS-compliant)

EXAMPLE OF ORDERING INFORMATION

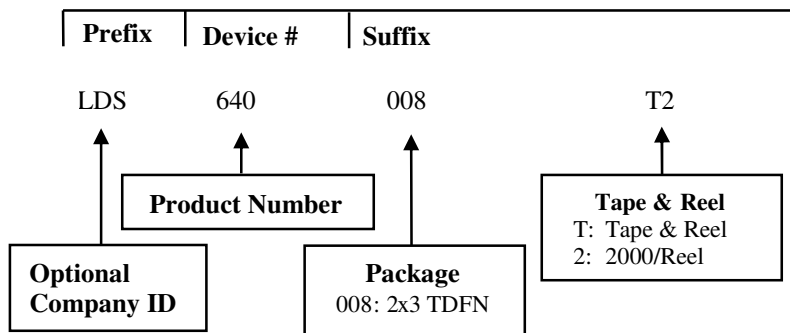

Notes:

- 1) All packages are RoHS-compliant (Lead-free, Halogen-free).
- 2) The standard lead finish is Matte-Tin.
- 3) The device used in the above example is a LDS8640 008-T2 (2x3 TDFN, Tape & Reel).
- 4) For additional package and temperature options, please contact your nearest IXYS Corp. Sales office.

Warranty and Use

IXYS CORP. MAKES NO WARRANTY, REPRESENTATION OR GUARANTEE, EXPRESS OR IMPLIED, REGARDING THE SUITABILITY OF ITS PRODUCTS FOR ANY PARTICULAR PURPOSE, NOR THAT THE USE OF ITS PRODUCTS WILL NOT INFRINGE ITS INTELLECTUAL PROPERTY RIGHTS OR THE RIGHTS OF THIRD PARTIES WITH RESPECT TO ANY PARTICULAR USE OR APPLICATION AND SPECIFICALLY DISCLAIMS ANY AND ALL LIABILITY ARISING OUT OF ANY SUCH USE OR APPLICATION, INCLUDING BUT NOT LIMITED TO, CONSEQUENTIAL OR INCIDENTAL DAMAGES.

IXYS Corp. products are not designed, intended, or authorized for use as components in systems intended for surgical implant into the body, or other applications intended to support or sustain life, or for any other application in which the failure of the IXYS Corp. product could create a situation where personal injury or death may occur.

IXYS Corp. reserves the right to make changes to or discontinue any product or service described herein without notice. Products with data sheets labeled "Advance Information" or "Preliminary" and other products described herein may not be in production or offered for sale.

IXYS Corp. advises customers to obtain the current version of the relevant product information before placing orders. Circuit diagrams illustrate typical semiconductor applications and may not be complete.



IXYS Corp.
1590 Buckeye Dr.,
Milpitas, CA 95035-7418
Phone: 408. 457.9000
Fax: 408. 496.0222
<http://www.ixys.com>

Document No: 8640_DS
Revision: N1.0
Issue date: 2/8/2011