

# CLP0212 Open Frame Power Supply

High-efficiency, Compact, Cost-effective



- 200W,12Vdc stand-alone power system
- 80 PLUS® Gold efficiency
- Maximum power in small space – 18W/in<sup>3</sup>
- No load power consumption less than 0.5 watts.
- Powering communications, computing, storage, and other OEM embedded applications

## Overview

In a 2 x 4 inch footprint smaller than an iPhone®, the 12Vdc single-output CLP0212 open frame power supply delivers [80 PLUS Gold](#) energy efficiency. Half the size of other power supplies in this segment, the CLP series is specifically designed to handle power challenges associated with tight space and low airflow. Offering a leading 18W/in<sup>3</sup> power density in a 1U high, fan-less form factor, the CLP series addresses a broad range of applications in new products from communications, computing and data storage original equipment manufacturers (OEMs).

As part of the GE Energy Total Efficiency™ architecture, the new CLP series delivers greater than 90 percent typical power efficiency and full load output at +50°C (122°F) with limited current de-rating at

higher temperatures. The CLP series utilizes a unique design approach at this power level, leveraging zero voltage switching techniques in conjunction with quasi-resonant power factor correction (PFC) circuits. Footprint real estate is minimized by optimizing transformer geometry and other components that are switching frequency dependent. Input range is 90-265Vac with 12ms hold up time, 100 kHz switching frequency, narrow 15 kHz frequency band and active PFC. Protection features include overcurrent (OCP), overvoltage (OVP), and overtemperature (OTP). Fault tolerance capabilities deliver N+1 redundancy for high-availability requirements. Certifications include FCC Class A, CE, CSA, TUV and UL.

## Benefits

### Reliability

- Proven design with limited current de-rating at higher temperatures
- N+1 redundancy configuration via 'remote' ON/OFF
- Full Protection: OCP, OVP, OTP

### Intelligence

- Thermal sensor shut down
- Remote sense control to address I<sup>2</sup>R drops

### Investment Protection

- Small footprint for compact communications, computing, storage and other OEM embedded power applications
- Leading efficiency in a small package
- 80 PLUS® Gold Certification
- Versatile configuration

### On Time Delivery

- 8-12 week availability
- Standard off-the-shelf product
- 24/7 technical support

### Total Efficiency

The GE Energy Total Efficiency™ (TE) architecture reduces energy loss and lowers cooling costs by 50-70%. TE products will prioritize sustainable energy sources like solar, wind, water and fuel cells over traditional utility grid or diesel generator sources – and they will intelligently respond to smart grid information to reduce consumption during peak demand periods. Active Rectifier Management™ (ARM) and Battery Charging Optimization™ (BCO) features increase efficiency on current and legacy power infrastructures. The Total Efficiency architecture addresses issues end-to-end based on our proven experience and expertise in batteries, power distribution, DC energy systems, AC-DC power supplies, and DC-DC board mounted power to deliver a solution that is more safe, reliable and energy efficient than alternatives from our competitors.



imagination at work

## Specifications

200 Watt +12Vdc Open Frame Power Supply	
Input Voltage Range	90-264 Vac, 47-63 Hz universal AC input range
Input Current Maximum	3A @ 90 Vac Full load (max)
Inrush Current	40A max. cold start (Measured at 25°C for all line conditions typical duration 10ms)
Input Protection	Designed to operate in harsh environmental conditions(per EN61000-4)
Power Factor	>0.95 typical at full load at nominal input
Efficiency	Greater than 90% efficiency at 50% load and 230 Vac operation
Output Power	200W, forced air cooling (200LFM/7CFM); 100W with convection cooling up to +50°C
Output Voltage Range	11.4~12.6 Vdc with potentiometer adjustment
Output Current	16.7A @ 12Vout
Standby Bias Voltage	5V @ 0.25A or 3.3V @ 0.25A (optional)
Voltage Regulation	±2% of Vo for any combination of line, load and temperature
Output Ripple & Noise	1% (pk-pk) @ 20MHz with 0.1µF ceramic and 10µF electrolytic caps at the output
Operating Temperature	-25°C to +70°C. Power derating above +50°C at 2.5%/°C (200LFM required to work in full power) -40°C operation available as an option
EMI	FCC/EN55022 Class A (conducted)
Analog Status & Control	Current sharing (CS), Remote On/Off, Remote Sense, Output DC-OK
Shock & Vibration	Per MIL STD-810E per 516.4 Part IV
Dimensions	2.00 x 4.00 x 1.4" (WxLxH)/ 50.8 x 101.6 x 35.6mm
Weight	0.35kg
Safety Approvals	UL and cUL approved to UL/CSA60950-1 standard, TUV (EN60950-1), CE Mark(for LVD) & CB Report

## Model Numbers

Standard	Output Voltage	Minimum Load	Maximum Load	Stand-By Supply	Air Flow Direction
CLP0212FPXX5Z01A	12.0Vdc	0A	16.7A	5.0V@0.25A	Normal (Diode Bridge to AC connector)
CLP0212FPXX3Z01A	12.0Vdc	0A	16.7A	3.3V@0.25A	Normal (Diode Bridge to AC connector)
CLP0212FPEX5Z01A	12.0Vdc	0A	16.7A	5.0V@0.25A	Extended temperature -40°C to +70°C (Diode Bridge to AC connector)

### Absolute Maximum Ratings

The Maximum Rating defines the most critical operation condition for the PSU (Power Supply Unit). Any application beyond the range may cause damage to the PSU or affect the reliability of normal operation.

Parameter/Symbol/Comments	Model	Min	Typ	Max	Unit
Maximum Input Voltage: AC continuous operation ( $V_{IN,AC}$ )	All models	90	-	264	Vac
Maximum Output Power $P_{O,max}$	All models	-	-	200 <i>Note 1</i>	W
Isolation Voltage Input to output Input to safety ground Outputs to safety ground	All models	- - -	- - -	3000 1500 50	Vac Vac Vac
Ambient Operating Temperature ( $T_A$ )	All models	-25	-	+75	°C
Storage Temperature ( $T_{STG}$ )	All models	-40	-	+85	°C
Humidity (non-condensing) Operating	All models	5	-	95	%
Altitude Operating	All models	-	-	4000 <i>Note 2</i>	m
MTBF 25 °C Calculated as per BELLCORE TR-332, Issue 6.				100,000	Hours

*Note 1: Full power 200W Convection Cooling (200LFM/7CFM)  
Half power 100W at 0 LFM*

*Note 2: The 4000 m test is in UL report*

Input Specifications

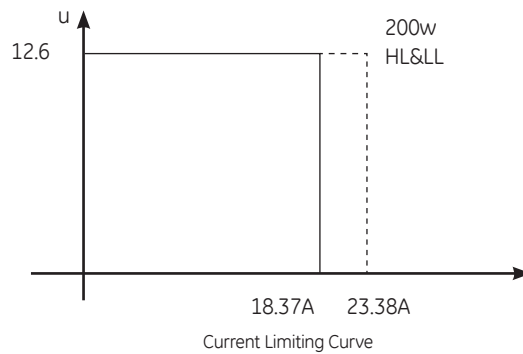
Parameter/Symbol/Comments	Conditions	Min	Typ	Max	Unit
Operating Input Voltage, ( $V_{IAC}$ ) Overvoltage Protection Point Undervoltage Protection Point		90 NU -	115/230	264 NU 90	Vac <sub>RMS</sub>
Input Vac Source Frequency		47	50/60	63	Hz
Maximum Input Current ( $I_{IN,max}$ ) ( $I_O = I_{O,max}, I_{VSTD} = I_{VSTD,Max}$ )	$V_{IAC} = 90V_{AC}$		4		A <sub>RMS</sub>
Harmonic Line Currents (THD)	All	EN 61000-3-2			
Power Factor	All	-	0.95	-	
Startup Surge Current (Inrush) @ 25°C	$V_{IAC} = 264V_{AC}$	-	-	40	A <sub>PK</sub>
Input Fuse	Internal, Line  5A, 250V	-	-	5	A
Isolation - Input to Output		-	-	3000	Vac
Isolation - Input to Chassis		-	-	1500	Vac
Leakage current to earth ground	$V_{IAC} = 264V_{AC}$ $f_{IAC} = 50/60$ Hz	-	-	3.5	mA
Operating Efficiency @ 25°C (full load)	$I_O = I_{O,max}$ $V_{IAC} = 100V_{AC}$ $V_{IAC} = 230V_{AC}$		90 92	- -	% %
System Stability:  Phase Margin Gain Margin		45 10	-	-	∅ dB

Output Specifications

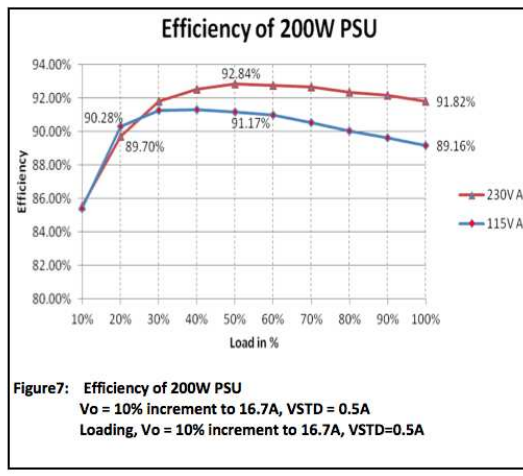
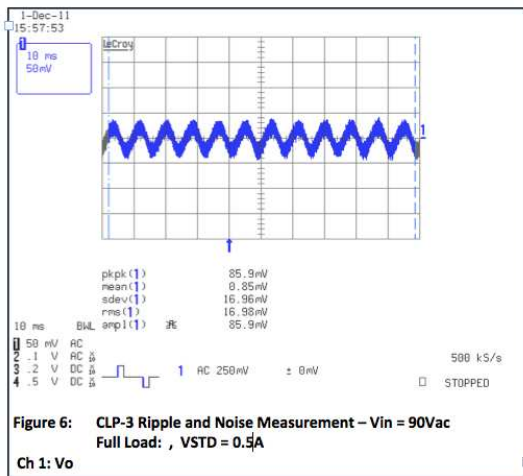
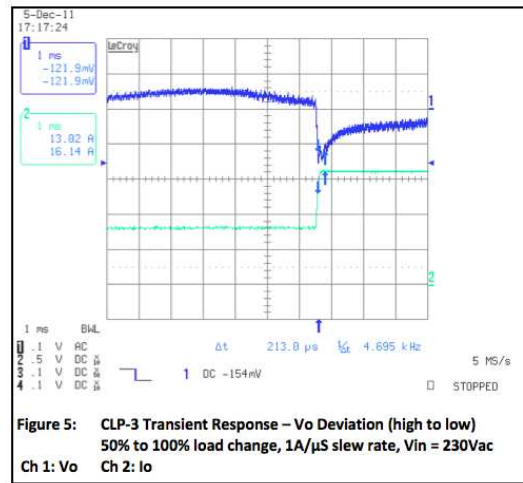
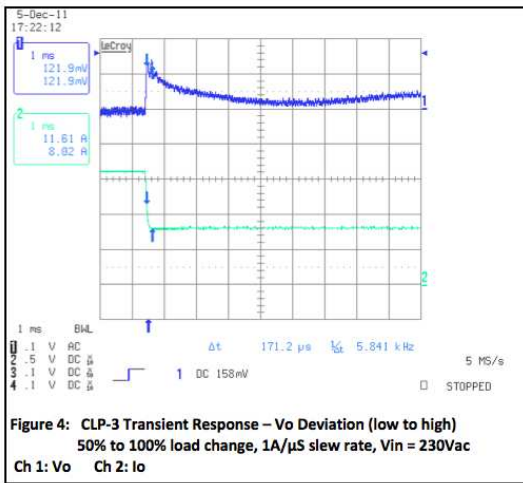
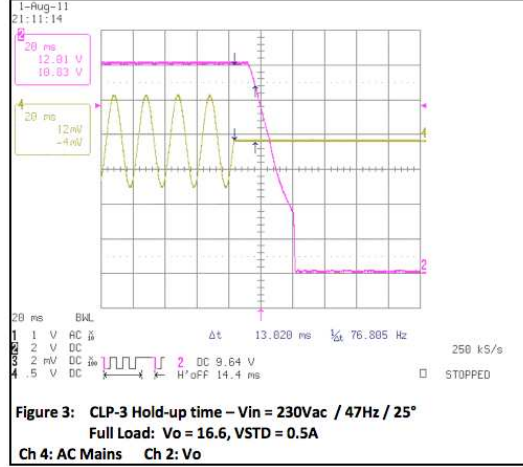
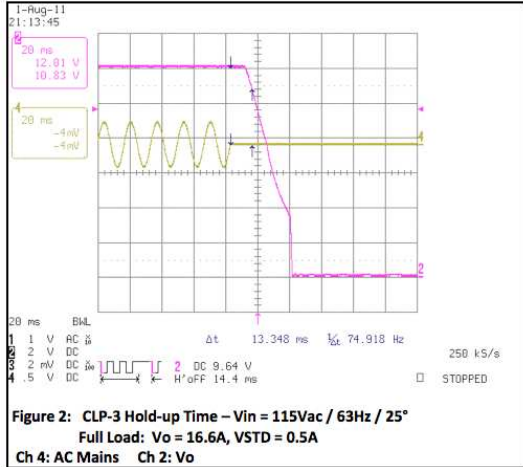
Parameter/Symbol/Comments	Conditions	Min	Typ	Max	Unit
Output Range	$V_o$	11.4	12.0	12.6	V
Output Regulation	$V_o$	-2%		2%	%
	$V_{VSTD}$	-5%		5%	
Output Ripple Noise	$V_o$	-		120	$mV_{PK-PK}$
	$V_{VSTD}$	-		50	
Output Current Free of Air/Fan cooling	$I_o$	0	-	8.3/16.7	A
	$I_{VSTD}$	0	-	0.125/0.25	
$V_o$ Current Share Accuracy	20% to 100% $I_o$	-5	-	5	% $I_o$
$V_o$ Load Capacitance	Start up	-		5000	$\mu F$
$V_o$ Dynamic Response Peak Deviation ( $\pm\%V_o$ ) Settling Time( $T_s$ )	20~50% load	-	-	5	%
	50%~100% load slew rate = 1A/ $\mu s$	-	-	500	$\mu Sec$
$V_o$ Long Term Stability Max change over 1000 hours( $\pm\%V_o$ )	$V_o$ and $V_{std}$			0.5	%

Efficiency

Items	Condition	Min	Typ	Max	Unit	Remark
Efficiency @ 230V AC input	20% load		88.5		%	+25°C ambient, 12Vout
	50% load		92.0		%	
	100% load		91.5		%	
Efficiency @ 115V AC input	20% load		88.0		%	+25°C ambient, 12Vout
	50% load		90.0		%	
	100% load		88.0		%	

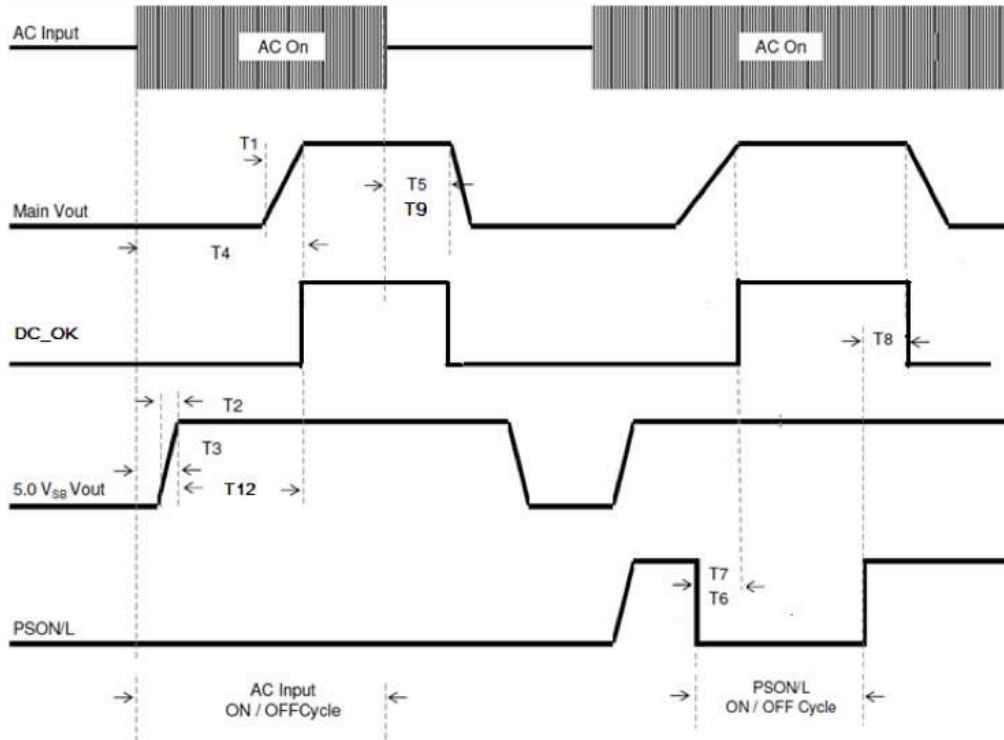


Output Specifications



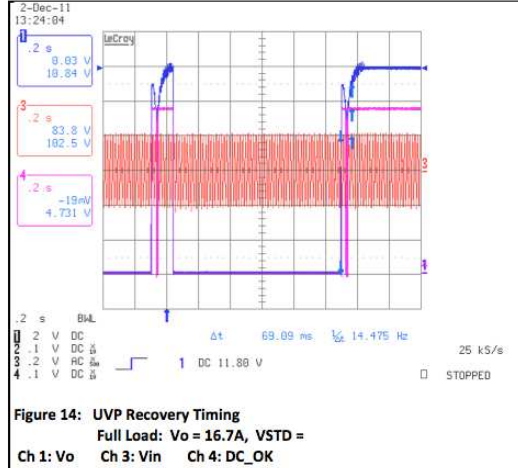
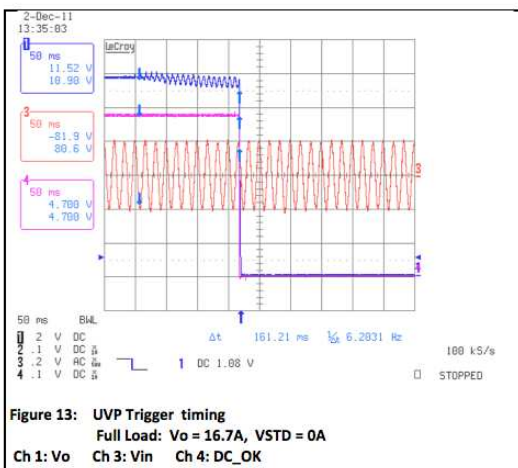
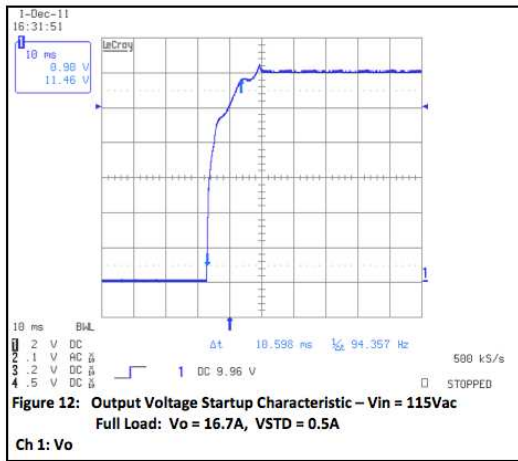
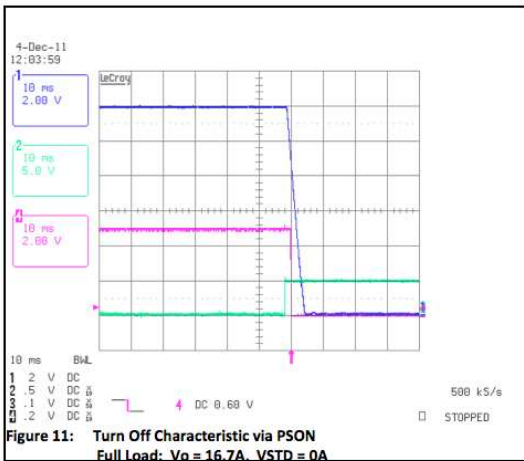
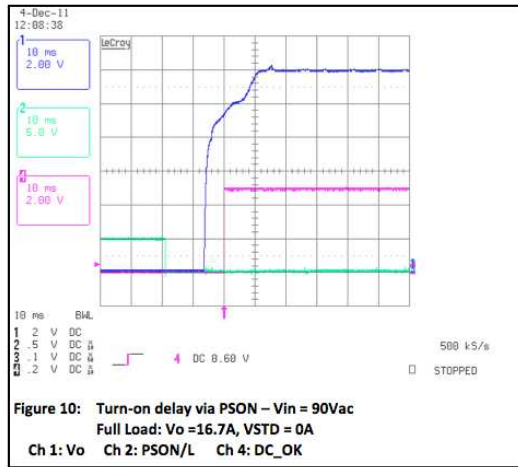
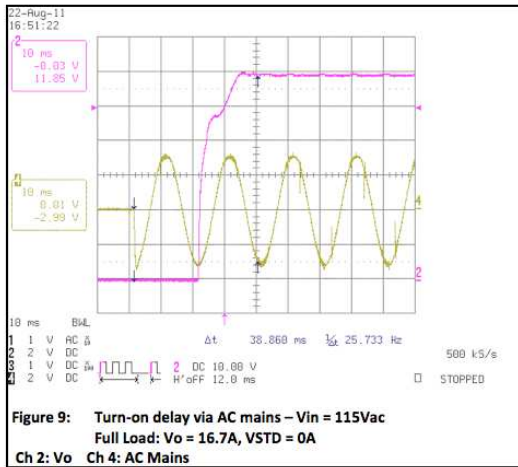
Timing Specifications

Label	Parameter	Min	Typ	Max	Unit
T1	Vo Output rise time (10%Vo to 90% Vo)	-	-	20	mSec
T2	3.3/5.0 Vstd output rise time (10%Vstd to 90% Vstd)	-	-	20	mSec
T3	Delay from AC being applied to 3.3/5.0 Vstd being within regulation.	-	-	500	mSec
T4	Delay from AC being applied to all output voltages being within regulation.	-	-	2000	mSec
T5	Time all output voltages, including 3.3/5.0 Vstd, stay within regulation after loss of AC.	12	-	-	mSec
T6	Delay from REMOTE ON/OFF active to output voltages starts to rise	-	-	50	mSec
T7	Duration of DC_OK being in the de-asserted state during an off/on cycle using the PSON signal.	-	-	50	mSec
T8	Delay from REMOTE ON/OFF de-active to DC_OK being de-asserted.	-	-	40	mSec
T9	Delay from loss of AC input to de-assertion of DC_OK/H.	12	-	-	mSec
T10	Delay from output voltages within regulation limits to DC_OK asserted at turn on.	-	-	-	mSec
T11	Delay from DC_OK de-asserted to Vo or 3.3/5.0 Vstd dropping out of regulation limits.	-	-	-	mSec
T12	Delay from 3.3/5.0 Vstd being in regulation to Vo being in regulation after AC turn on.	-	-	100	mSec

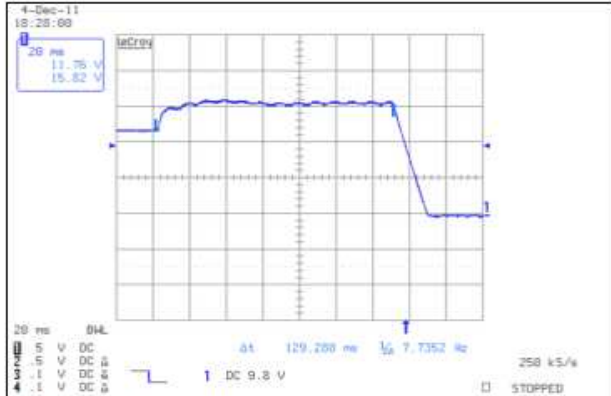


System Timing Diagram

Timing Specifications

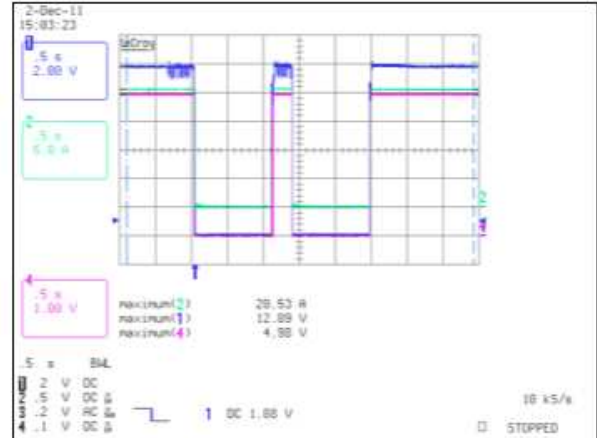


Timing Specifications

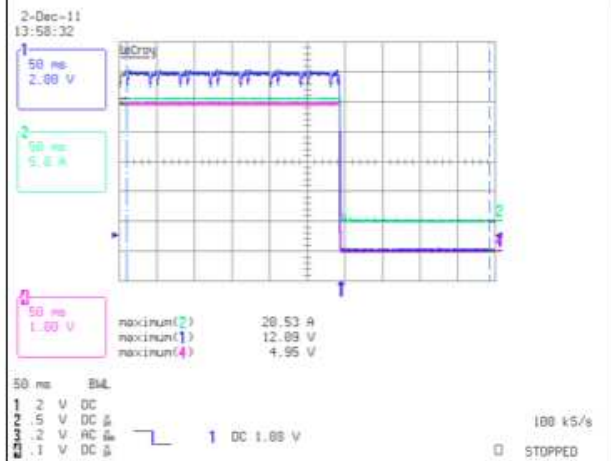


**Figure 15: OUTPUT OVP Trigger Timing**  
Full Load:  $V_o = 16.7A$ ,  $V_{STD} = 0A$

Ch 1:  $V_o$



**Figure 16: OCP Recovery Timing**  
Ch 1:  $V_o$  Ch 2:  $I_o$  Ch 4:  $DC\_OK$



**Figure 17: OCP Trigger Timing**  
Ch 1:  $V_o$  Ch 2:  $I_o$  Ch 4:  $DC\_OK$

## Protections

### Overcurrent Protection (OCP)

The CLP series includes internal current limit circuitry to prevent damage in the event of overcurrent or short circuit. The Vo will auto recover when the load is back to normal.

Parameter	Min	Nom	Max	Unit
Vo Output Overcurrent	110	-	140	%Full load
5V Standby Overcurrent	110	-	200	%Full load

### Overvoltage (OVP)

Overvoltage (OVP) protection is offered as a feature to protect both the load and the PSU from overvoltage condition and occurs between 110-130% of Vout nominal at 200W. During an overvoltage event, the internal current limit is sensed and the power supply goes into hiccup mode operation (on/off cycling) until the over load condition is removed. Recovery is auto restart and does not require the end user to recycle the AC input. The OV range is from 13.8 V min to 15V max.

Parameter	Min	Nom	Max	Unit
Vo Output Overvoltage	13.8	-	15	V

### Overtemperature Protection (OTP)

The CLP series power supply incorporates thermal protection to prevent damage or degradation due to overheating. The power supply will turn off if there is an overtemperature condition (200W @ ambient temperature +60°C). Once the temperature of the power supply is reduced to within normal limits, the power supply will restart automatically.

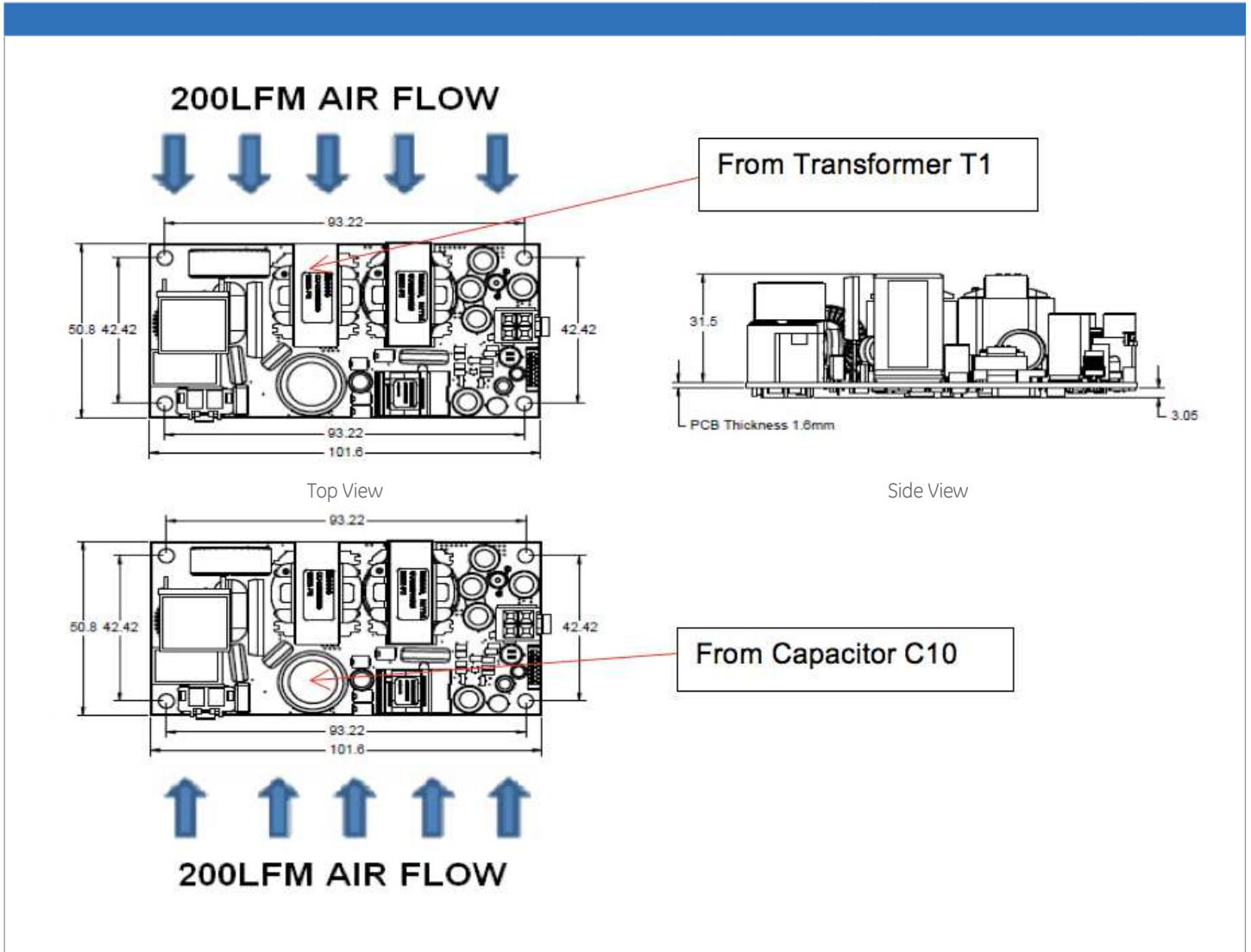
### Short Circuit Protection (SCP)

Output voltage of less than 0.5V constitutes a short. The CLP0212FP will go into short circuit protection and Vout will go into hiccup mode until the condition is removed. SCP protection only applies to the main V1 output.

Mechanical Outlines

Signal Connector – HDR 3

Airflow Direction Options



## Power / Signal Mating Connectors and Pin Types

Mating Connectors for CLP series

Reference	On Power Supply	Mating Connector or Equivalent
AC Input Connector	5-1376382-1 from Tyco or equivalent	1376388-1 from Tyco
Output Connector	39-28-1043 from Molex	39-01-2040 from Molex
Signal Connector	53047-0810 from Molex or equivalent	51021-0800 from Molex

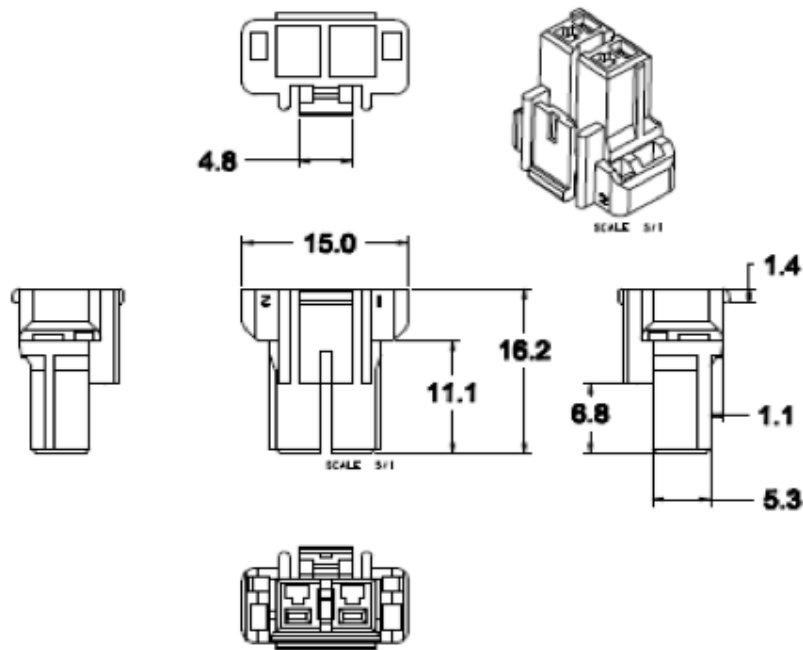
### Mating Connector Drawing

#### Input Connector - HDR 1

Part Description: Plug Housing 2 Pin, 10A, 300V

Manufacturer Name: Tyco Electronics

Manufacturer Part No: 1376388-1



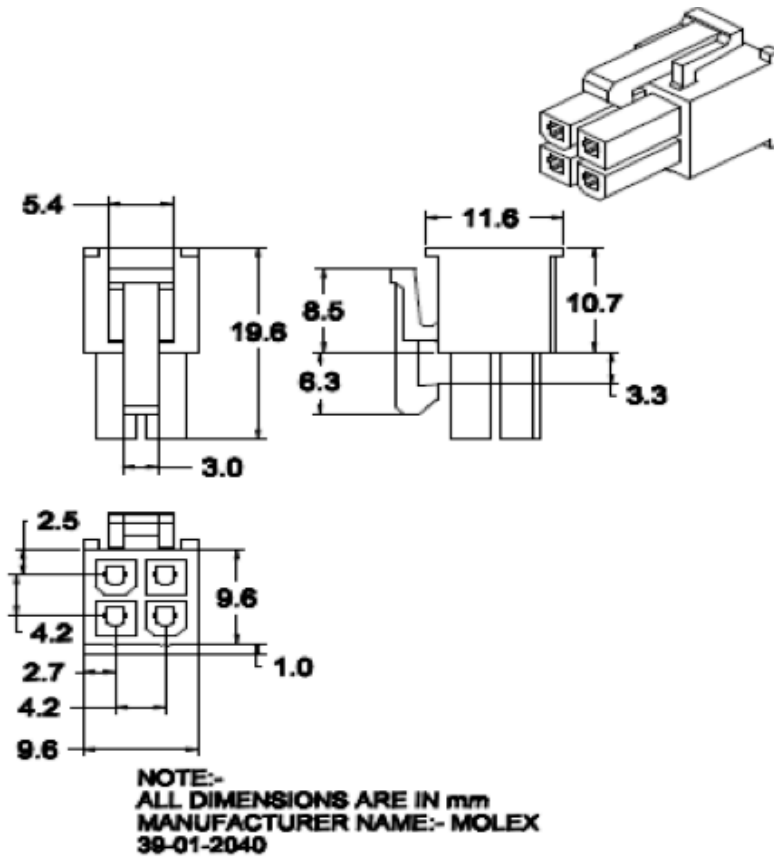
**NOTE:-ALL DIMENSIS ARE IN mm  
MANUFACTURER:- TYCO ELECTRONICS  
PART NO:- 1376388-1**

## Output Connector – HDR 2

Part Description: Housing 4 Pin, 13A, 600V

Manufacturer Name: MOLEX

Manufacturer Part No: 39-01-2040

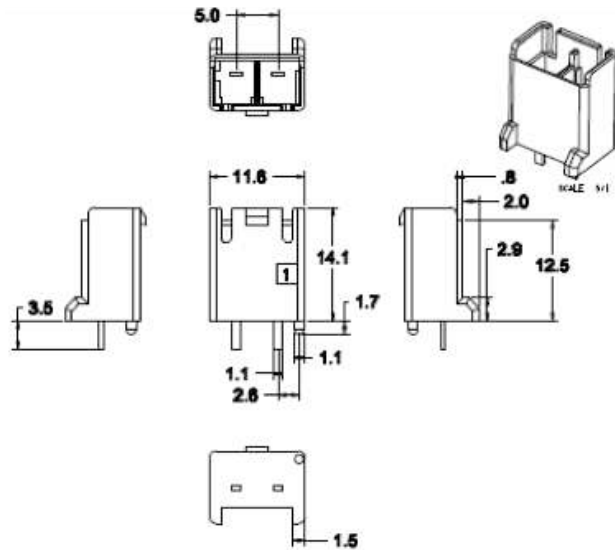


## PSU Connector Definitions

### Input Connector – HDR 1

This connector supplies the AC Mains to the CLP power supply.

Description	
Pin-1	LINE
Pin-2	NEUTRAL

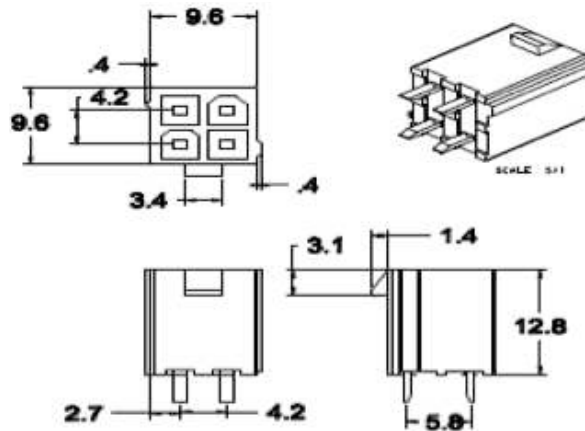


**NOTE:-ALL DIMENSIOIS ARE IN mm  
MANUFACTURER:- TYCO ELECTRONICS  
PART NO:- 6-1378382-1**

### Output Connector - HDR 2

These pins provide the main output for the CLP.

Pin	Description	Pin	Description
Pin-1	Vo	Pin 3	RTN
Pin-2	Vo	Pin 4	RTN



**NOTE:-ALL DIMENSIONS ARE IN mm  
MANUFACTURER : MOLEX  
PART NO:- 39-28-1043**

**Signal Connector - HDR-3**

The CLP series contains a control signal header providing an analog control interface, standby power and i<sup>2</sup>C interface. These are control signals which are directly connected from the system to the power supply.

HDR-3	Pin Description	Pin-outs
CS	Current share	Pin- 1
+S	Remote sense (+ve)	Pin- 2
-S	Remote sense (-ve)	Pin- 3
On/off	Remote on/off	Pin- 4
DC-OK	Output DC-OK	Pin- 5
COM	Output common	Pin- 6
COM	Output common	Pin- 7
V2	+5V	Pin- 8

**Signal Connector Details**

<p>Part Description: Wire-to-Board Header, Vertical, with Friction Lock, 8 Circuits.            Manufacturer Name : MOLEX            Manufacturer Part No : 53047-0810</p>	<p>Part Description : Wire-to-Board Housing, Female, 8 Circuits            Manufacturer Name : MOLEX            Manufacturer Part No : 51021-0800</p>

**Remote Sense + Remote Sense -**

The main output of the CLP is equipped with a Remote Sensing capability that will compensate for a power path drop around the entire loop of 100mV. This feature is implemented by connecting the remote sense + and the remote sense - to the positive and negative rails of the main output, respectively, at a location that is near the load. Care should be taken in routing the sense lines as any noise sources or additional filtering components introduced into the voltage rail may affect the stability of the power supply. The CLP will operate appropriately without the sense lines connected; however, it is recommended that the sense lines be connected directly to the main output terminals if remote sensing is not required. This remote sense circuit will not raise the power supply's output voltage to the OVP trip level. Main Output Remote Sense has no effect on the Standby Output (VSTD).

**Load Share/Paralleling (ISHARE)**

Analog signal-single wire connection-Ishare bus voltage at full load: 2.5V for a single supply. Above 20% full load unit will load share within ±5% of full load.

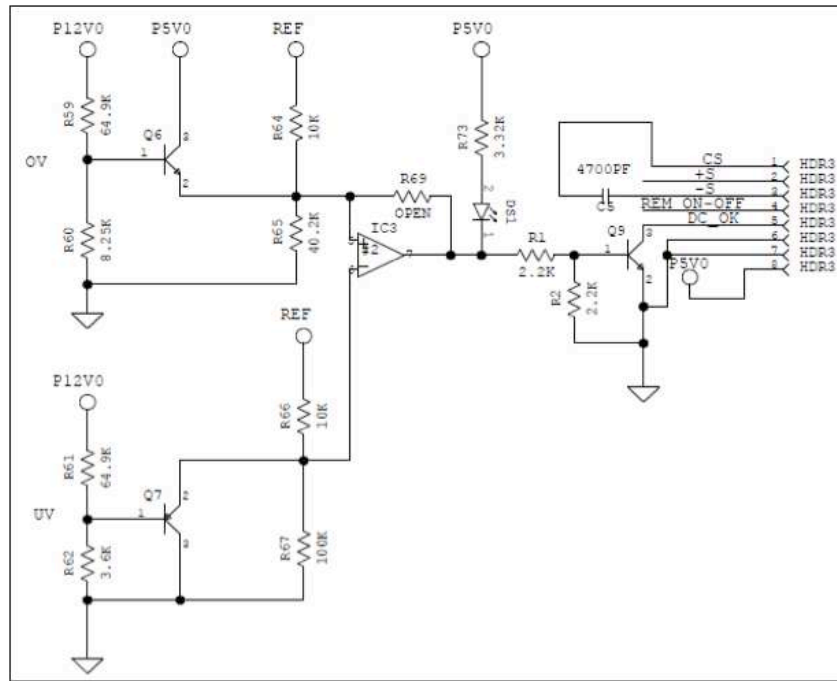
**Remote ON/OFF**

TTL-compatible. Open collector (High) for normal operation. Sink current: 1mA. Max collector voltage: 12Vdc  
 Logic 1 (TTL High) or open enables unit (ON); Logic 0 (TTL Low) or short shuts unit down (OFF).  
 Cycling this signal resets the overvoltage protection memory

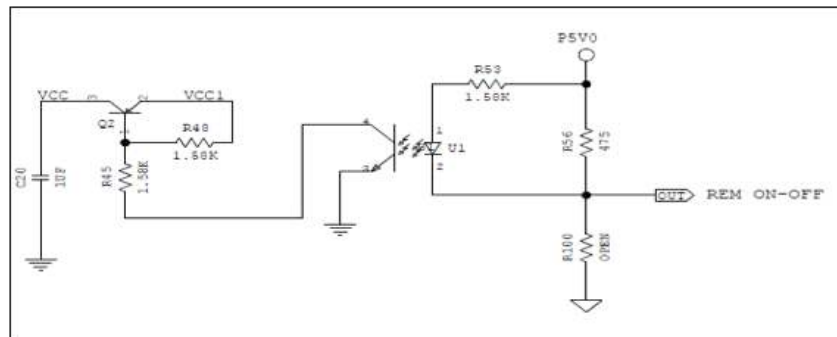
**DC OK**

TTL-compatible. Open collector (High) for normal operation. Sink current: 4mA. Max collector voltage: 12Vdc

Key Signal Interface Diagram



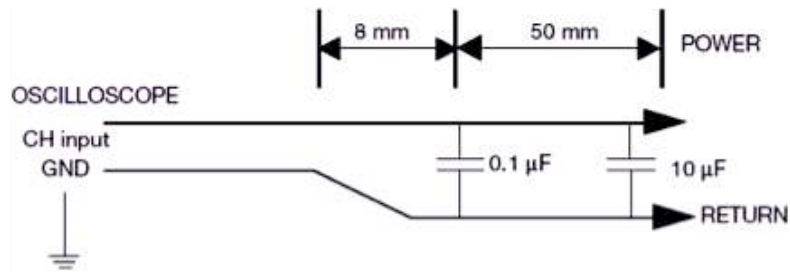
DC OK Fail Indication Signal /DC OK



Remote On/Off

## Output Ripple and Noise Measurement

The setup outlined in the diagram below has been used for output voltage ripple and noise measurements on the CLP Series. When measuring output ripple and noise, a scope jack in parallel with a 0.1 $\mu$ F ceramic chip capacitor and a 10 $\mu$ F aluminum electrolytic capacitor should be used. Oscilloscope should be set to 20MHz bandwidth for this measurement.



Output voltage ripple & noise measurement method

## Visual Indicators (LEDs)

DC OK (Green)

## Environmental Specifications

### EMC Immunity

The CLP series power supply is designed to meet the below EMC immunity specifications.

Parameter	EN61000	Criteria
ESD	4-2, Level 3	A
Radiated susceptibility	4-3, Level 3	A
Electrical fast transient common mode	4-4, Level 3	A
Surge	4-5, Level 3	A
Conducted RF immunity	4-6, Level 3	A
Voltage dips	4-11, Level 3	B,C, interruption
Harmonics Emission	3-2,	A

### EMC Emission

The CLP series has been designed to comply with the Class A and Class B (\*) limits of EMI requirements. For Class B EMI, external filter circuitry is required.

Parameter	EN55022	Criteria
Conducted Emission	150k-30MHz, 3dB margin	A
Radiated Emission	30M-1GHz, 3dB margin	A

### Safety Certifications

The CLP power supply is intended for inclusion in other equipment and the installer must ensure that it is in compliance with all the requirements of the end application. This product is only for inclusion by professional installers within other equipment and must not be operated as a stand-alone product. The power supply will meet Class 1, IEC60950, EN60950, with the following deviations: Nemko. UL 60950 (Recognized Component) C-UL (Canadian Approval by UL)

### Operating Temperature

The operating temperature range is 0°C to +50°C at the full rated output power. The unit will start at temperature -25°C to <0°C meeting operating specifications after a 30 minute warm up period. Output power derated as 2.5%/ °C from 51° to 70° C. Non-operating/storage temperature range is -40°C to +85°C.

### Storage and Shipping Temperature / Humidity

The CLP series power supplies can be stored or shipped at temperatures between -40°C to +85°C and relative humidity from 5% to 95% non-condensing.

### Altitude

The CLP series power supplies will operate within specifications at altitudes up to 4000 meters with the output derating defined in Operating Temperature section.

According to IEC60664-1, required clearances have been adjusted by multiplying the clearance at sea level by a factor of 1.29 for operating at an altitude of 4000 meters. The correction factor is based on barometric pressure of 70kPa and Overvoltage Category II. If the calculated clearance exceeded the creepage, the creepage was adjusted to the value of clearance.

## Humidity

The CLP series power supplies will operate within specifications when subjected to a relative humidity from 5% to 95% non-condensing and can be stored in a relative humidity from 5% to 95% non-condensing.

## Vibration

The CLP series power supplies will pass the following vibration specifications:

Operating Shock: Three shocks, 15G peak, 11mS sinusoidal,  $\pm 1$  mS. Both directions of perpendicular axis.

Non-Operating Shock: Three shocks, 50G peak, 11mS sinusoidal,  $\pm 1$  mS. Both directions of perpendicular axis.

Operating and Non-Operating Vibration: 5-9Hz, 0.5" double amplitude, 2G PK, 0.5 oct./min, 2 cycles; 9-500Hz, 4G pk-pk, 0.5 oct./min, 2 cycles.

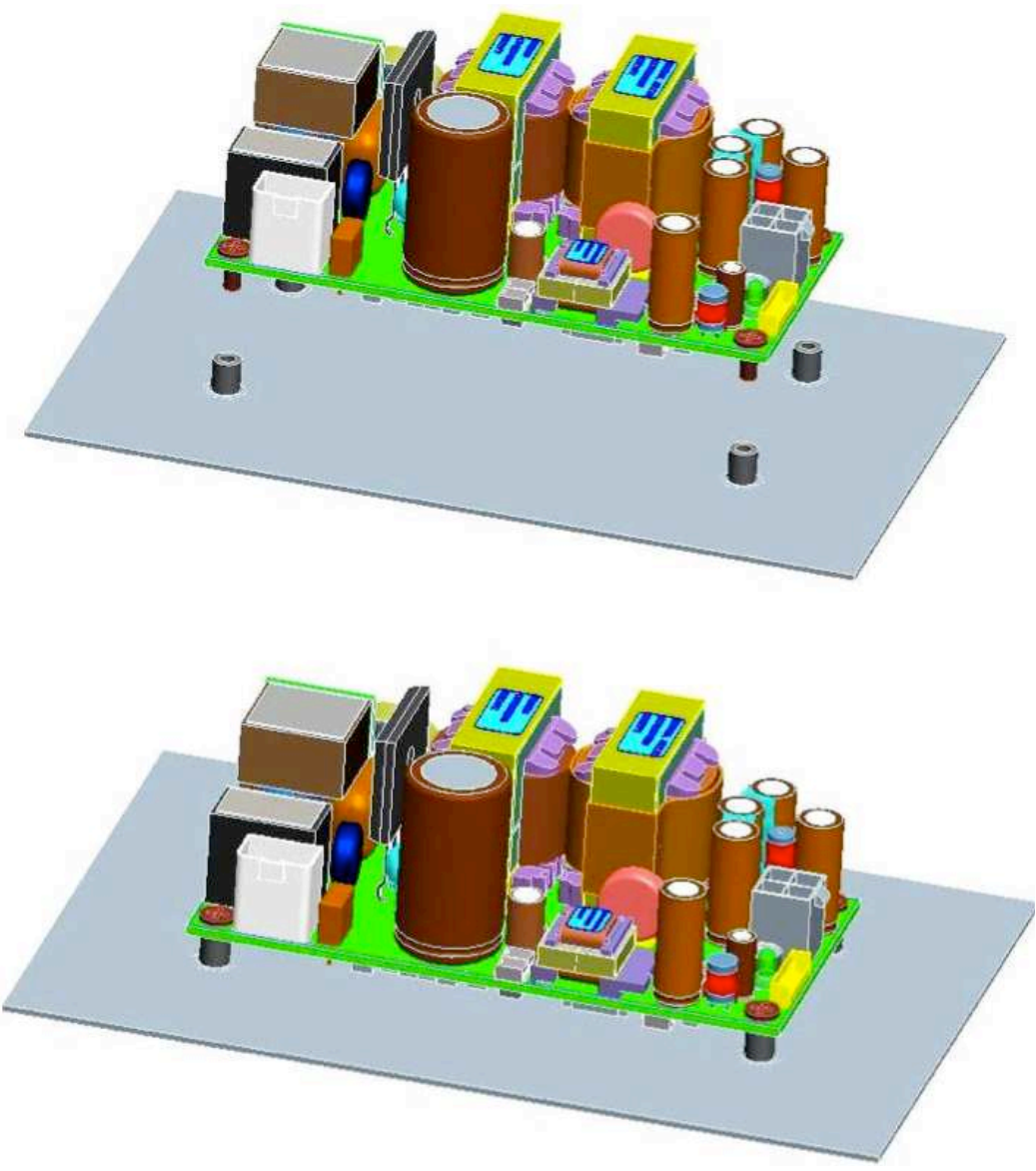
## MTBF

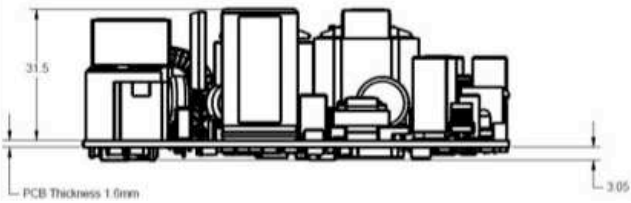
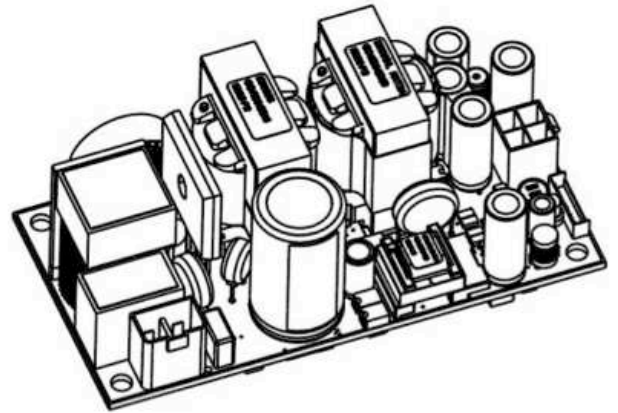
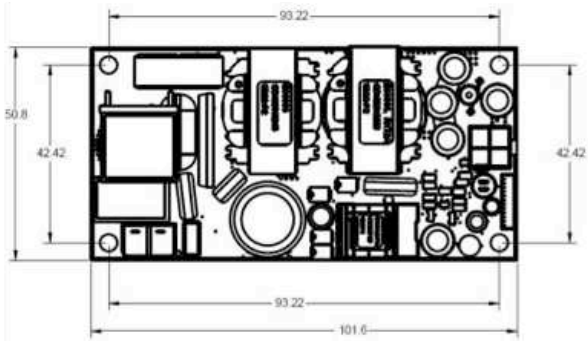
MTBF @ 25°C is more than 100,000 hours, which is calculated as per BELLCORE TR-332, Issue 6.

## Acoustic Noise Emissions

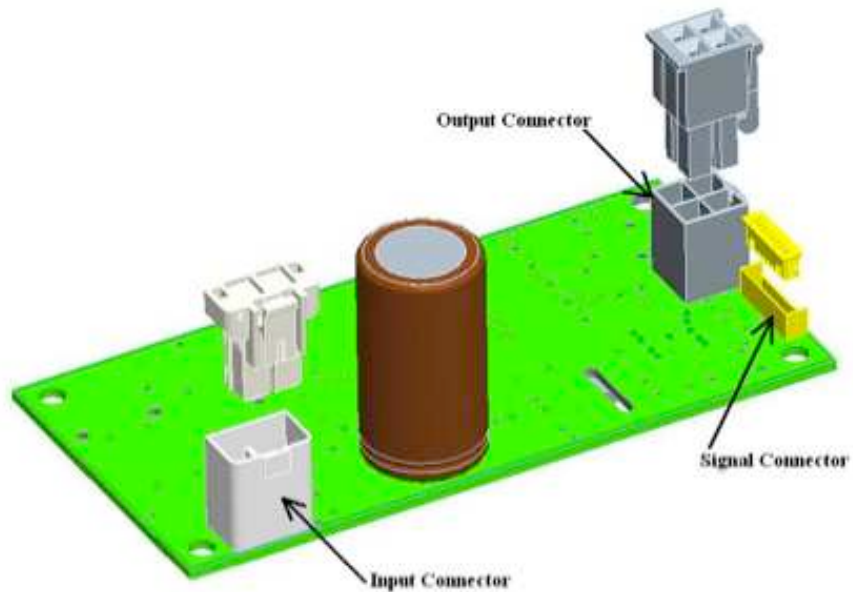
When operated with specified cooling under any steady-state or repetitive dynamic load within the range specified in this document, the power supply will meet the below requirements.

Model	Acoustic Requirements
CLP Series	As a fan-less PSU, the operational acoustic noise should be less than 40dB when measured at a 1 meter high table, 1.5 meters away from the front panel of the PSU





Note: Please use appropriate UL approved insulators on the top & bottom of the power supply unit.

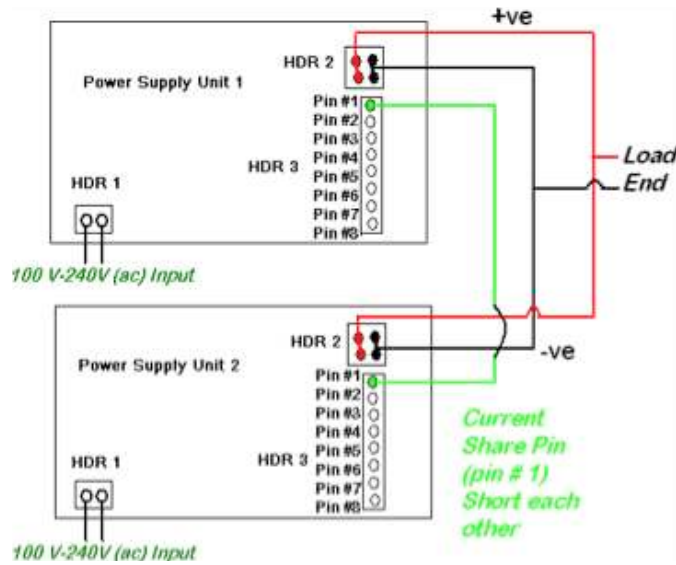


# Application Notes

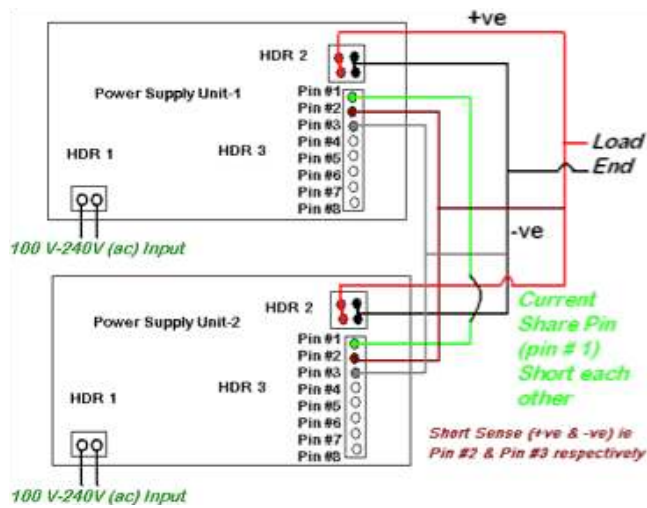
## Current Sharing

The CLP series main output is equipped with current sharing capabilities. This will allow up to 4 power supplies to be connected in parallel for higher power applications. All outputs with active current sharing will share load current within 10% of the average current at operating load. This will be valid for all loads greater than 20% rated output. For loads less than 20% of rated output, the share will be 5% of the full rated output.

### Arrangement 1 – No cable drop compensation

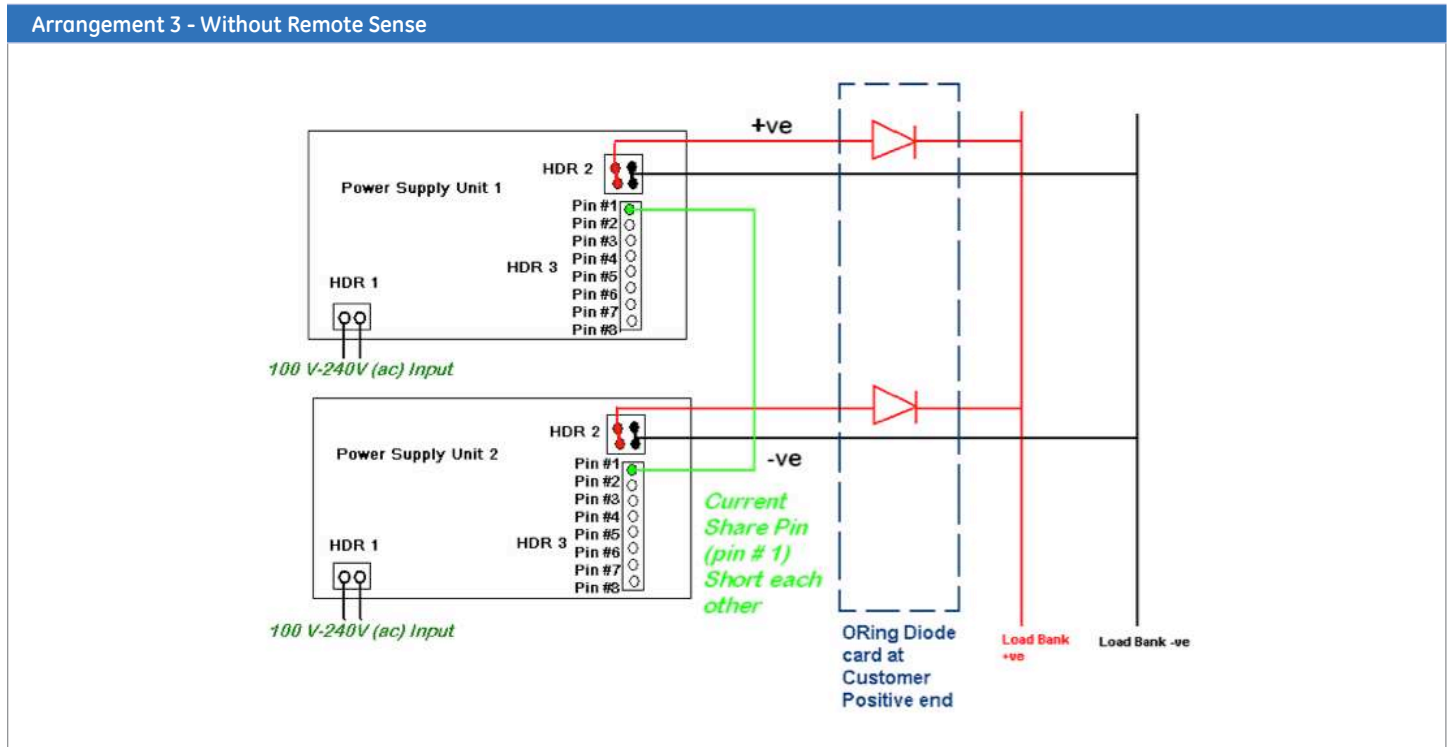


### Arrangement 2 – Cable drop compensation

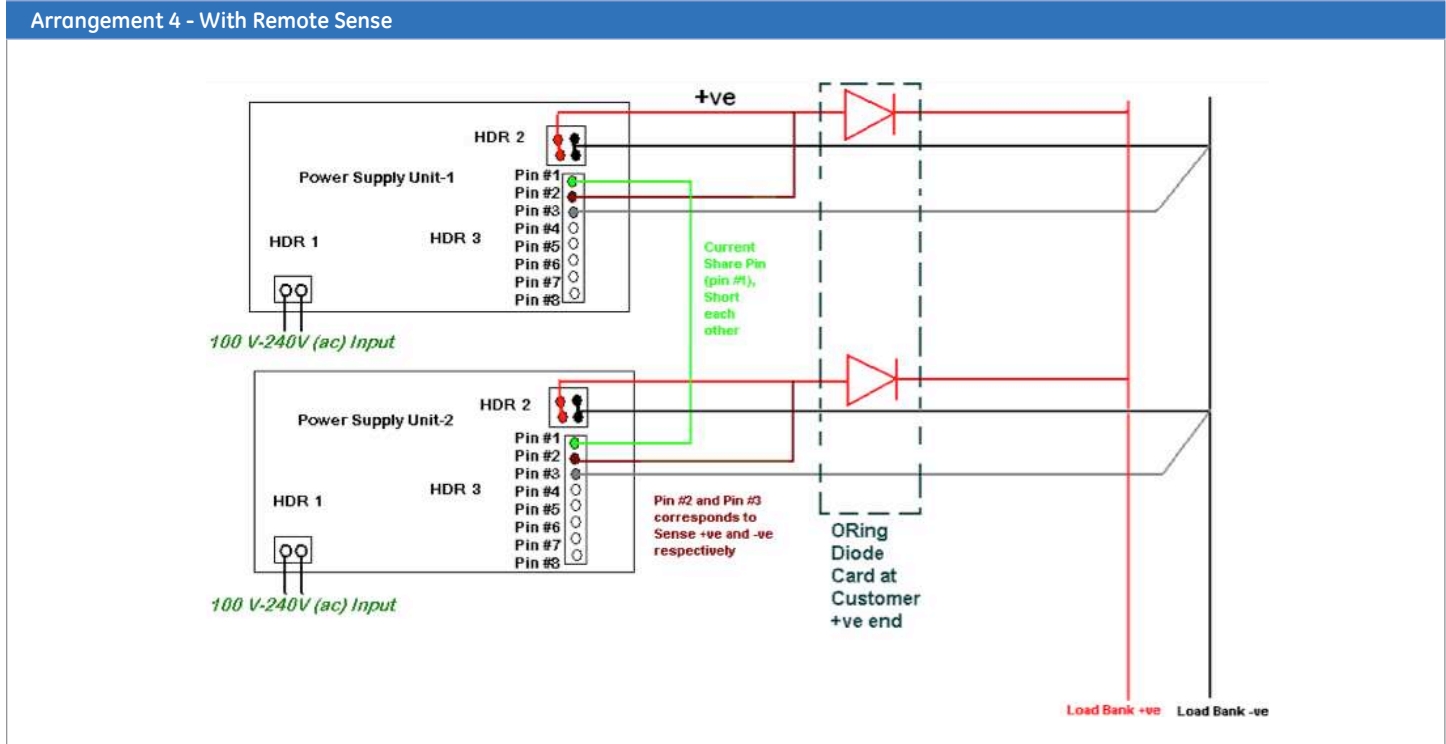


Redundancy / Fault Tolerance

The CLP series power supplies can be connected in the following way to provide redundancy/fault tolerance operation:



- Power measurement of 200W to be at PCB connector end for individual power supply .
- Cable Length drop should not be more than 0.125V +ve and 0.125V -ve.
- Current Share pin 1 of HDR3 connects each of the other of two power supplies.



- To compensate the cable drop, connect remote sense wires as shown in Arrangement 4 by connecting Pin # 2 and Pin # 3 of HDR3 at +ve end (Anode of oring diode) and -ve of load end respectively of the two power supplies as shown in diagram .
- Cable Length drop should not be more than 0.125V +ve and 0.125V -ve.
- Power measurement at PCB connector end should not exceed 200w for individual power supply.
- Current Share pins 1 of HDR3 connect each of the other of two power supplies.

The main output will be capable of operating in a redundant current share mode. A maximum of 4 power supplies may be operated in parallel. All outputs will incorporate an isolation device for fault isolation. Filter capacitors that are located after the isolation device will be highly reliable and de-rated sufficiently to minimize failures.

Outputs of two (or more) supplies connected in parallel must meet the regulation requirements of a single supply. Under normal operation with two (or more) supplies running in parallel, the outputs must share load current. If one of the supplies fails, the remaining supply (supplies) must pick up the entire load without causing the output to go out of regulation. A defective supply that is connected to the output voltage bus will cause no adverse effect on the bus or the operation of the remaining functional supply (supplies).

When the parallel units operate within the specified input, output conditions, power up and power down conditions, the power supplies will not exhibit instability. The maximum allowed load current is calculated as  $0.9 * N * \text{Single PSU Max rated current}$ . The bus voltage will be within the regulation band and the bus' periodic and random deviation will meet individual differential supply specification requirements. At initial start-up, the load will be limited to the rating of one power supply.

Output	Voltage (V)	For N power supplies in parallel Combined current (A)	Load step Current (A)
Vo	12.0	$N \text{ PS} - 16.7A * N * 0.9$	9.7
Vstd	3.3/5.0	$N \text{ PS} - 0.25A * N$	0.125

## Service & Support

GE Energy field service and support personnel are trusted advisors to our customers – always available to answer questions and help with any project, large or small. Our certified professional services team consists of experts in every aspect of power conversion with the resources and experience to handle large turnkey projects along with custom approaches to complex challenges. Proven systems engineering and installation best practices are designed to safely deliver results that exceed our customers' expectations.

## Warranty

GE Energy is committed to providing quality products and solutions. We have developed a comprehensive warranty that protects you and provides a simple way to get your products repaired or replaced as soon as possible.

For full warranty terms and conditions please go to [www.ge.com/powerelectronics](http://www.ge.com/powerelectronics).



GE Energy

## Contact Us

For more information, call us toll free at **+1 888 546 3243**, or +1 972 244 9288 and visit us on the web at [www.ge.com/powerelectronics](http://www.ge.com/powerelectronics)