

Triple video buffer/filter for HD video applications

Features

- 6th order filtering of 36 MHz
- 5 V single-supply operation
- Internal input DC level shifter
- No input capacitor required
- Three matched 6 dB amplifiers
- AC or DC output-coupled
- Very low harmonic distortion
- Specified for 150 Ω loads
- Minimum and maximum data is tested during production

Applications

- High-end video systems
- High definition TV (HDTV)
- Broadcast and graphic video
- Multimedia products

Description

The TSH346 is a triple single-supply video buffer featuring an internal gain of 6 dB and a 36 MHz filtering for HD video outputs on 75- Ω video lines.

The TSH346 is ideal to drive either YUV, YPbPr or RGB signals from video DAC outputs. The main advantage of this circuit is that its input DC level shifter allows for video signals on 75- Ω video lines without damaging the synchronization tip of the video signal, and with no input capacitor, while using a single 5 V power supply. The DC level shifter is internally fixed and optimized to keep the output video signals between low and high output rails. This level is as low as possible to minimize the output DC level in the video line.

The TSH346 is available in an SO-8 plastic package for optimum space saving.

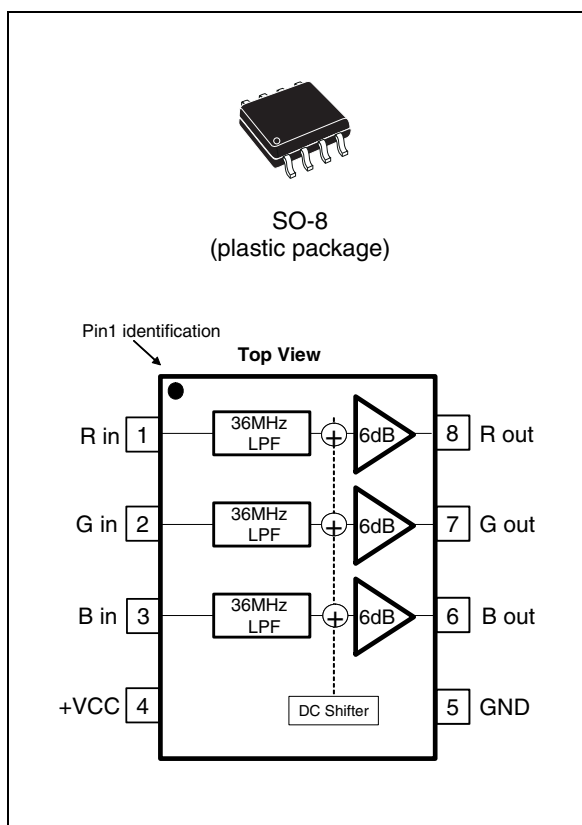

1 Absolute maximum ratings and operating conditions

Table 1. Absolute maximum ratings (AMR)

Symbol	Parameter	Value	Unit
V_{CC}	Supply voltage ⁽¹⁾	6	V
V_{in}	Input voltage range ⁽²⁾	2.5	V
T_{oper}	Operating free air temperature range	-40 to +85	°C
T_{std}	Storage temperature	-65 to +150	°C
T_j	Maximum junction temperature	150	°C
R_{thjc}	SO8 thermal resistance junction to case	28	°C/W
R_{thja}	SO8 thermal resistance junction to ambient area	150	°C/W
$P_{max.}$	Maximum power dissipation (at $T_{amb} = 25^\circ\text{C}$) for $T_j = 150^\circ\text{C}$	1	W
ESD	CDM: charged device model	500	V
	HBM: human body model	2	kV
	MM: machine model	100	V

1. All voltage values, except the differential voltage, are with respect to the network terminal.
2. The magnitude of the input and output voltages must never exceed $V_{CC} + 0.3\text{ V}$.

Table 2. Operating conditions

Symbol	Parameter	Value	Unit
V_{CC}	Power supply voltage	4.5 to 5.5 ⁽¹⁾	V

1. Tested in full production with a +5 V single power supply.

2 Electrical characteristics

Table 3. $V_{CC} = +5\text{ V}$ single supply, $T_{amb} = 25^\circ\text{ C}$ (unless otherwise specified)

Symbol	Parameter	Test conditions	Min.	Typ.	Max.	Unit
DC performance						
V_{DC}	Output DC shift	$R_L = 150\ \Omega$, T_{amb}	100	240	440	mV
		$-40^\circ\text{ C} < T_{amb} < +85^\circ\text{ C}$		310		
I_{ib}	Input bias current	T_{amb} , input to GND		1.3	3.6	μA
		$-40^\circ\text{ C} < T_{amb} < +85^\circ\text{ C}$		1.4		
R_{in}	Input resistance			1		$\text{M}\Omega$
C_{in}	Input capacitance			0.1		pF
I_{CC}	Total supply current	No load, input to GND		44.6	51.6	mA
		$-40^\circ\text{ C} < T_{amb} < +85^\circ\text{ C}$		45		
G	DC voltage gain	$R_L = 150\ \Omega$, $V_{in} = 0.5\text{ V}$	1.96	2	2.05	V/V
		$-40^\circ\text{ C} < T_{amb} < +85^\circ\text{ C}$		1.96		
Output characteristics						
V_{OH}	High level output voltage	$R_L = 150\ \Omega$	3.4	3.9		V
		$-40^\circ\text{ C} < T_{amb} < +85^\circ\text{ C}$		3.8		
V_{OL}	Low level output voltage	$R_L = 150\ \Omega$		47		mV
I_{OUT}	I_{source}		76	100		mA
		$-40^\circ\text{ C} < T_{amb} < +85^\circ\text{ C}$		91		
	I_{sink}		106	134		
		$-40^\circ\text{ C} < T_{amb} < +85^\circ\text{ C}$		126		
Filtering						
High definition	Bandwidth	Small signal, $V_{ICM} = 0.5\text{ V}$, $R_L = 150\ \Omega$ -3 dB bandwidth -1 dB bandwidth	25	36 32		MHz
	Attenuation	Small signal, $F = 74.25\text{ MHz}$ $V_{ICM} = 0.5\text{ V}$, $R_L = 150\ \Omega$	25	32		dB
D	Delay between each channel			0.5		ns
Noise						
eN	Total input voltage noise	$F = 100\text{ kHz}$, $R_{IN} = 50\ \Omega$		86		$\text{nV}/\sqrt{\text{Hz}}$

Figure 1. Filtering

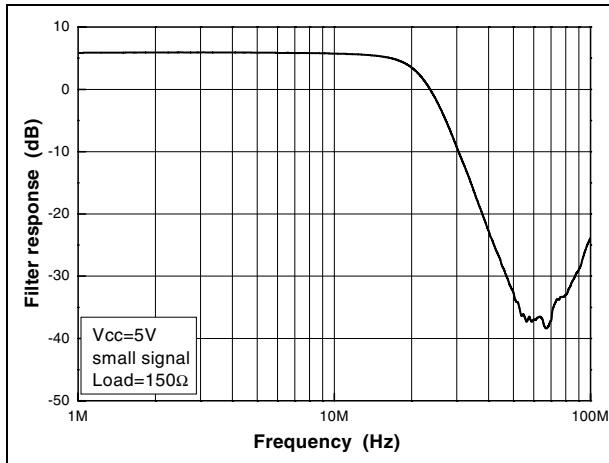

Figure 2. Gain flatness

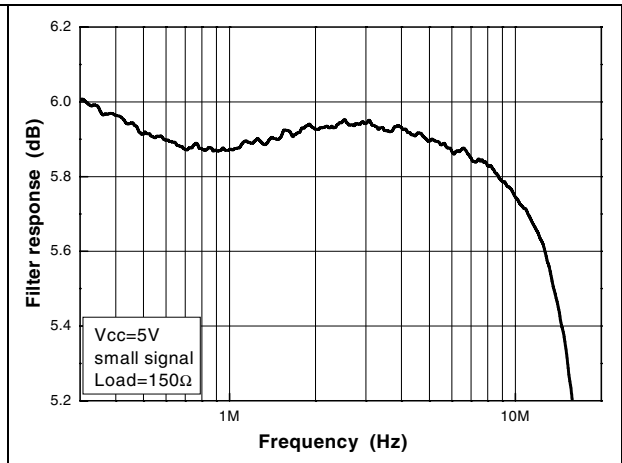

Figure 3. Distortion 1 MHz (HD)

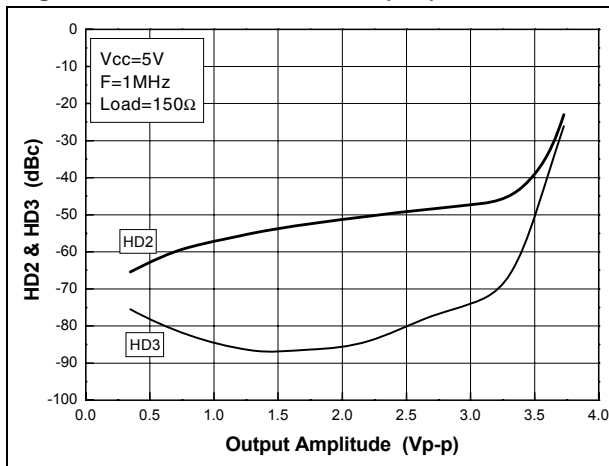

Figure 4. Distortion 10 MHz (HD)

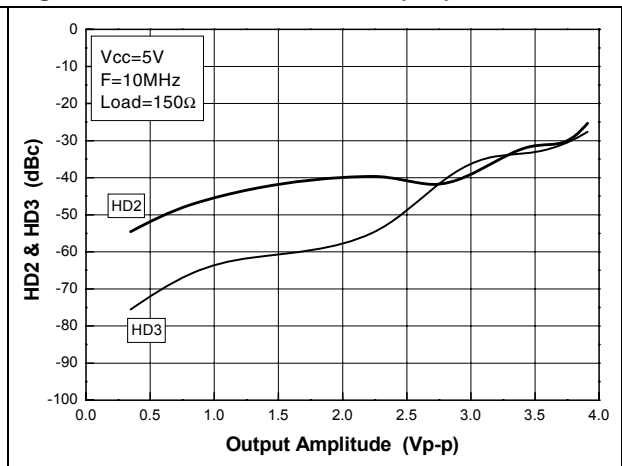

Figure 5. Input noise vs. frequency

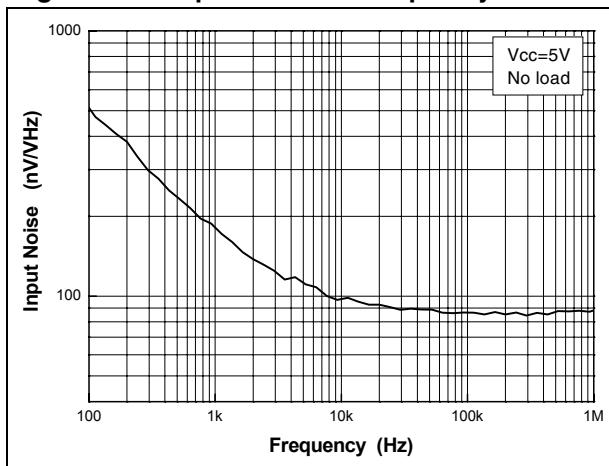

Figure 6. Channel crosstalk vs. frequency

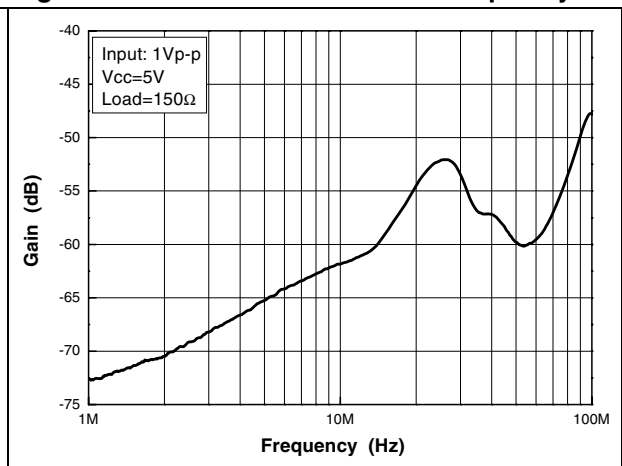

Figure 7. Gain vs. input amplitude

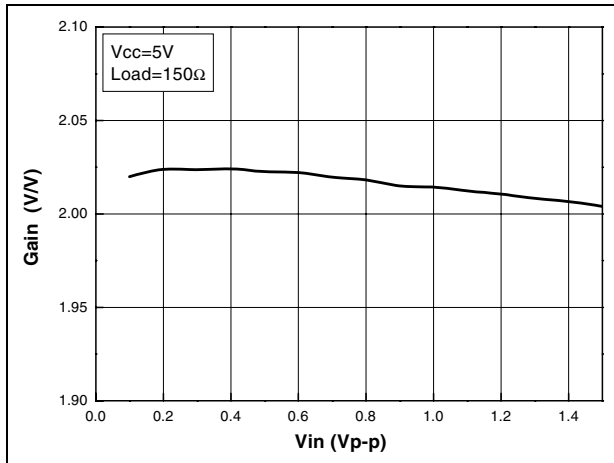

Figure 8. Output vs input amplitude

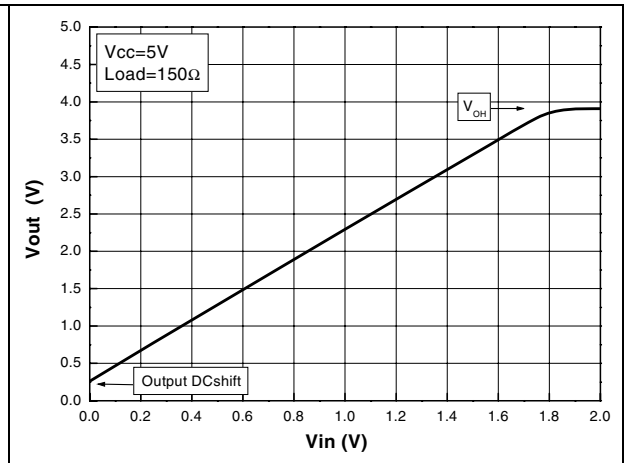

Figure 9. Current consumption vs. supply

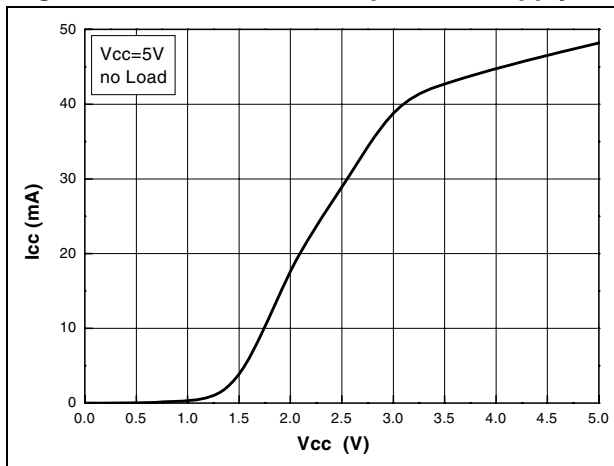

Figure 10. Supply current vs. temperature

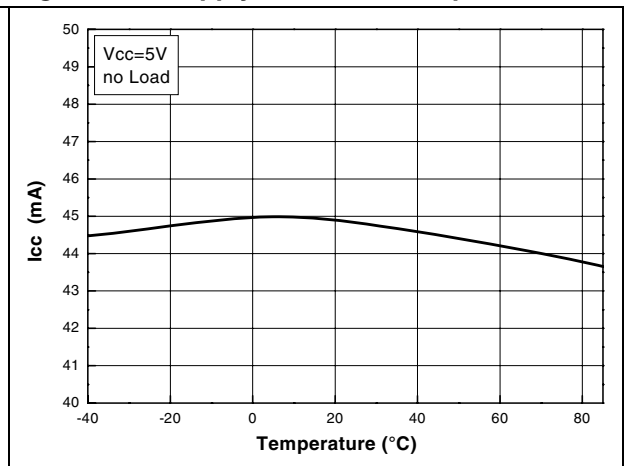

Figure 11. Filtering vs. temperature

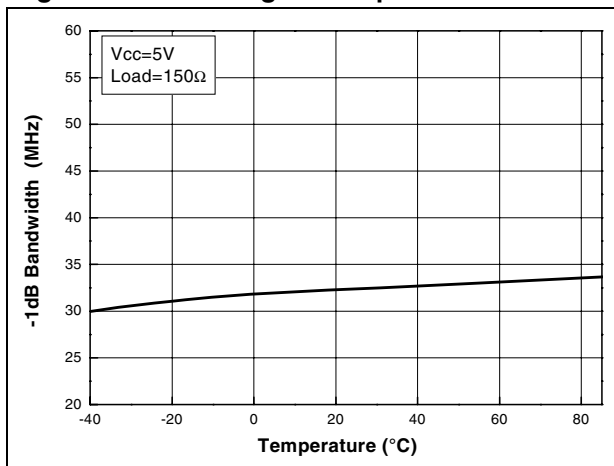

Figure 12. Filter attenuation vs. temperature

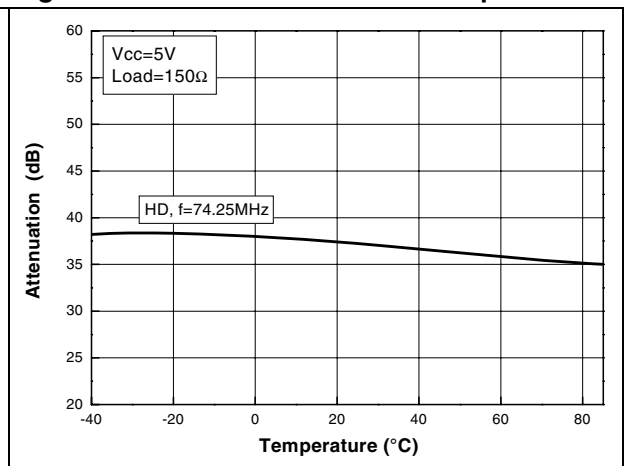

Figure 13. Gain matching vs. temperature

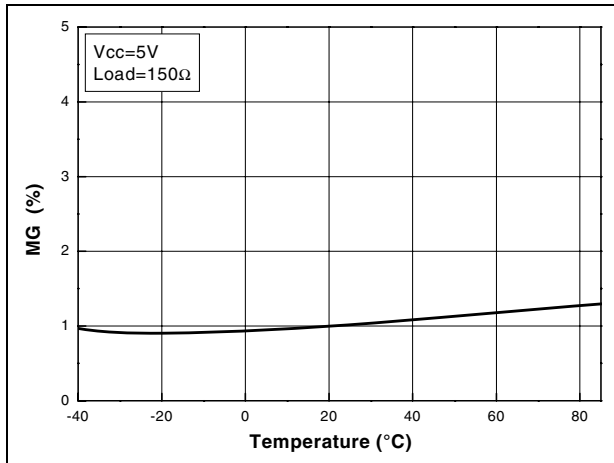

Figure 14. Output DC shift vs. temperature

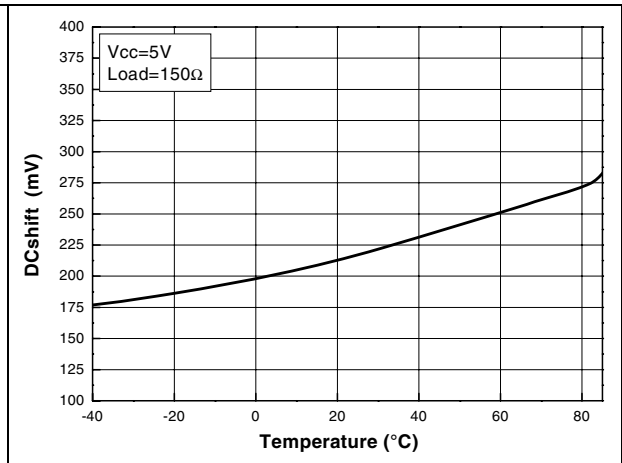

Figure 15. Isink vs. temperature

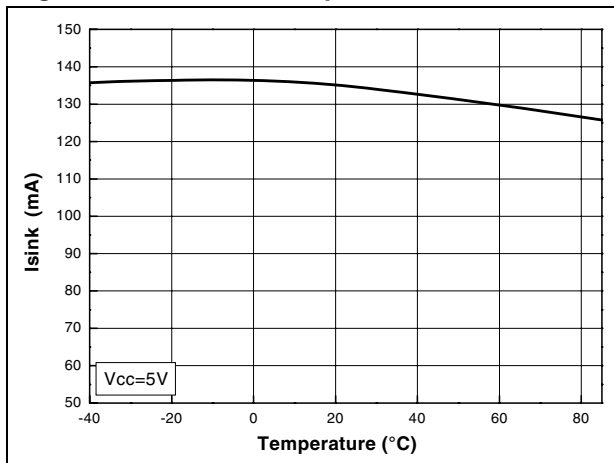

Figure 16. Isource vs. temperature

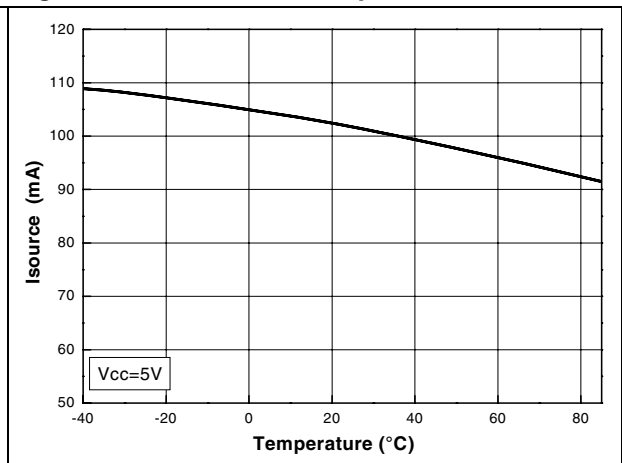

Figure 17. Ibias vs. temperature

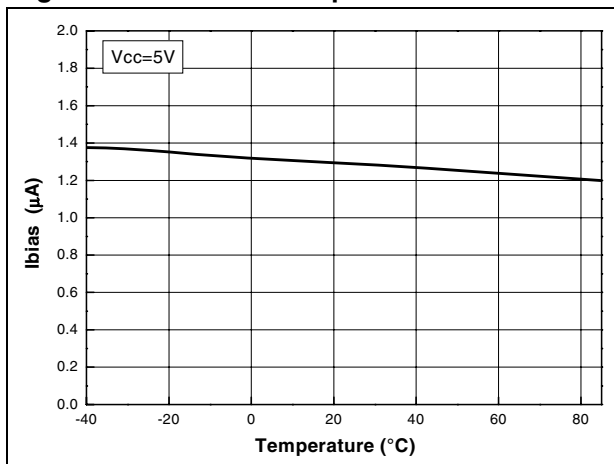

Figure 18. VOH vs. temperature

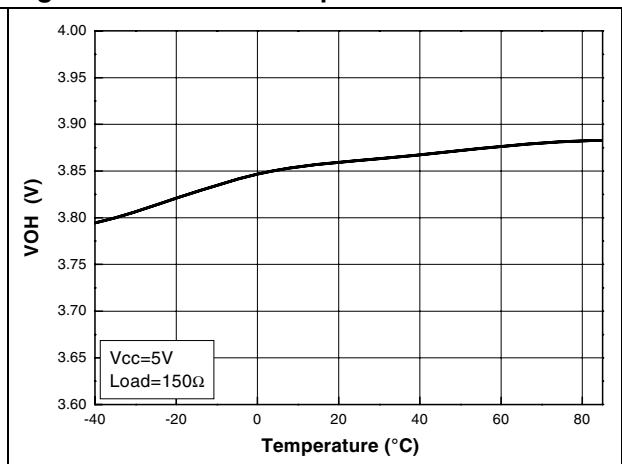

Figure 19. VOL vs. temperature

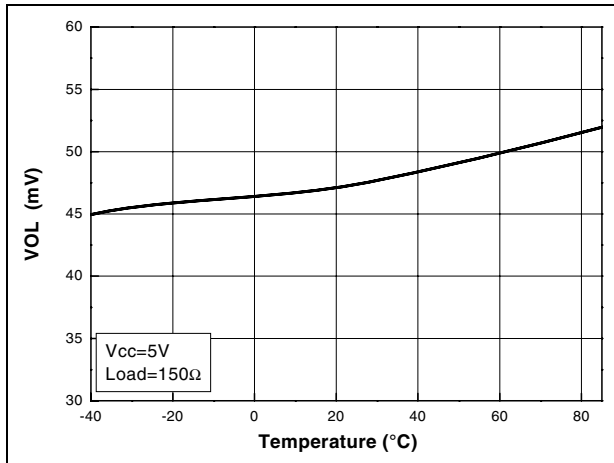
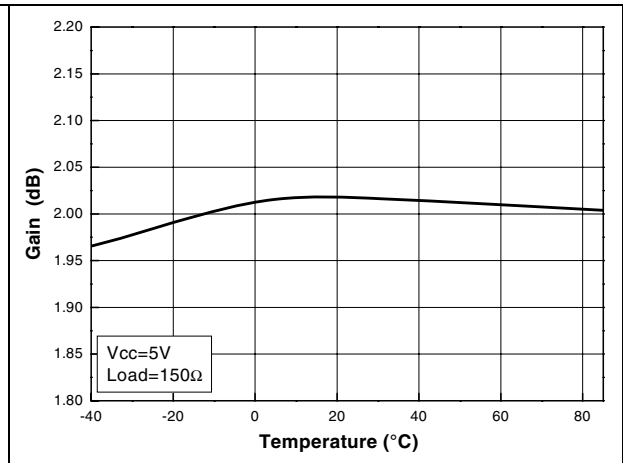

Figure 20. Gain vs. temperature



3 Power supply considerations and improvement of the PSRR

Correct power supply bypassing is very important to optimize performance in low and high-frequency ranges. Bypass capacitors should be placed as close as possible to the IC pin (pin 4) to improve high-frequency bypassing. A capacitor (C_{LF}) greater than $10\ \mu\text{F}$ is necessary to improve the PSRR in low frequencies. For better quality bypassing, a capacitor of $100\ \text{nF}$ (C_{HF}) can be added. C_{HF} must be placed as close as possible to the IC pin, to improve the noise supply rejection in the higher frequency ranges. A coil can be added in order to better reject the noise from the supply and to prevent current peaks as much as possible.

Figure 21. Circuit for power supply bypassing

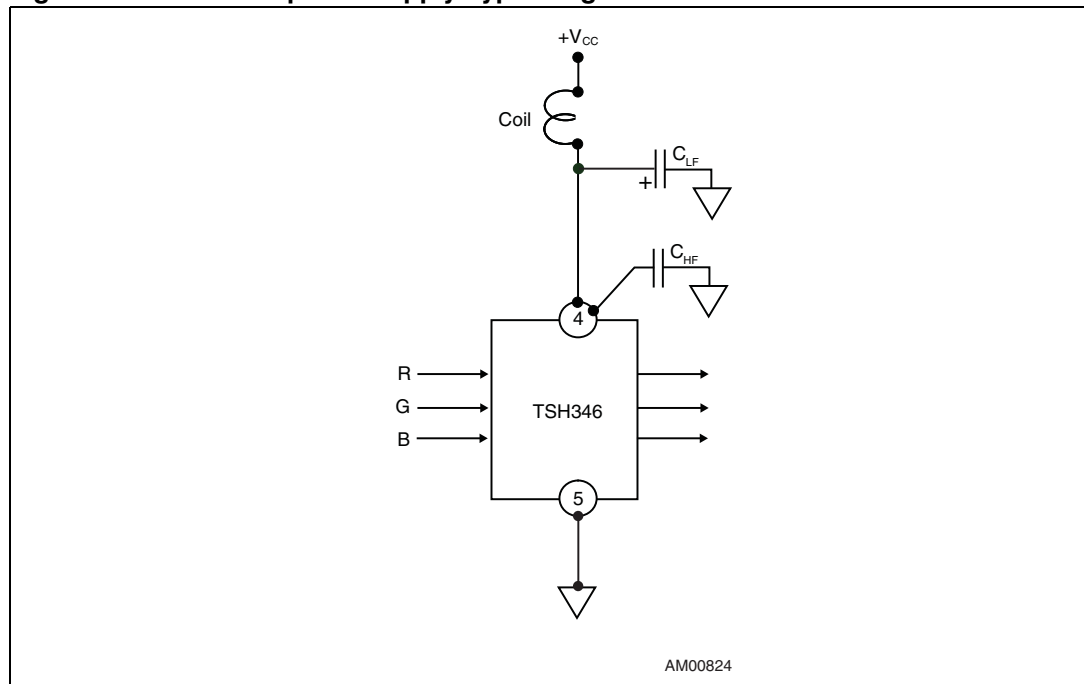

Figure 22. Circuit for noise rejection improvement measurement

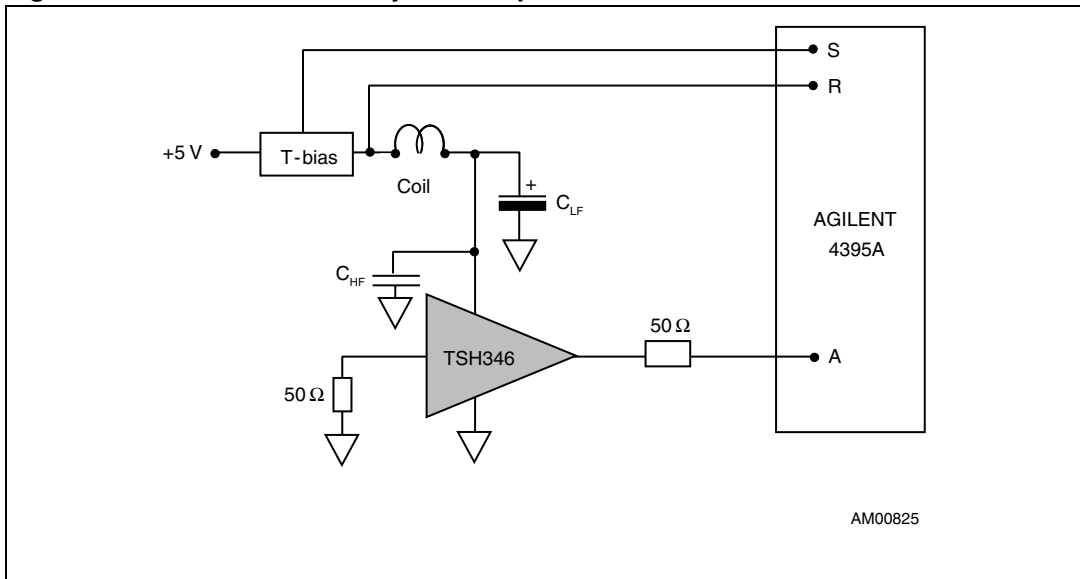
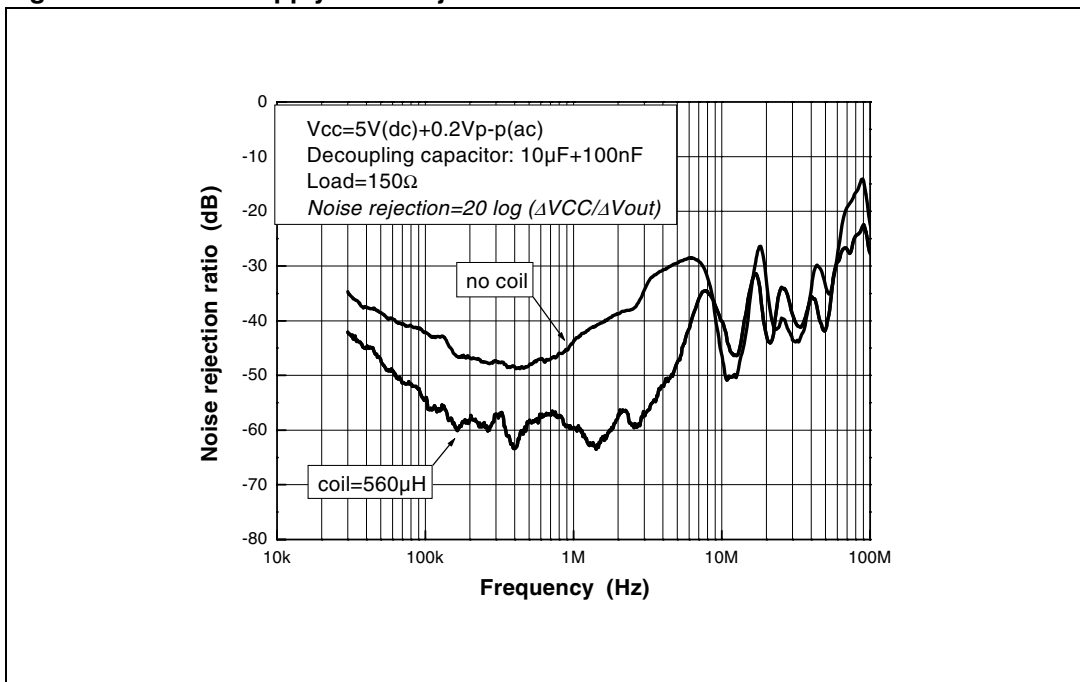

Figure 23 shows how the power supply noise rejection evolves versus frequency depending on how carefully the power supply decoupling is achieved.

Figure 23. Power supply noise rejection



4 Using the TSH346 to drive YC, CVBS, YUV, YPbPr and RGB video components

Figure 24. Implementation of the video driver on output video DACs

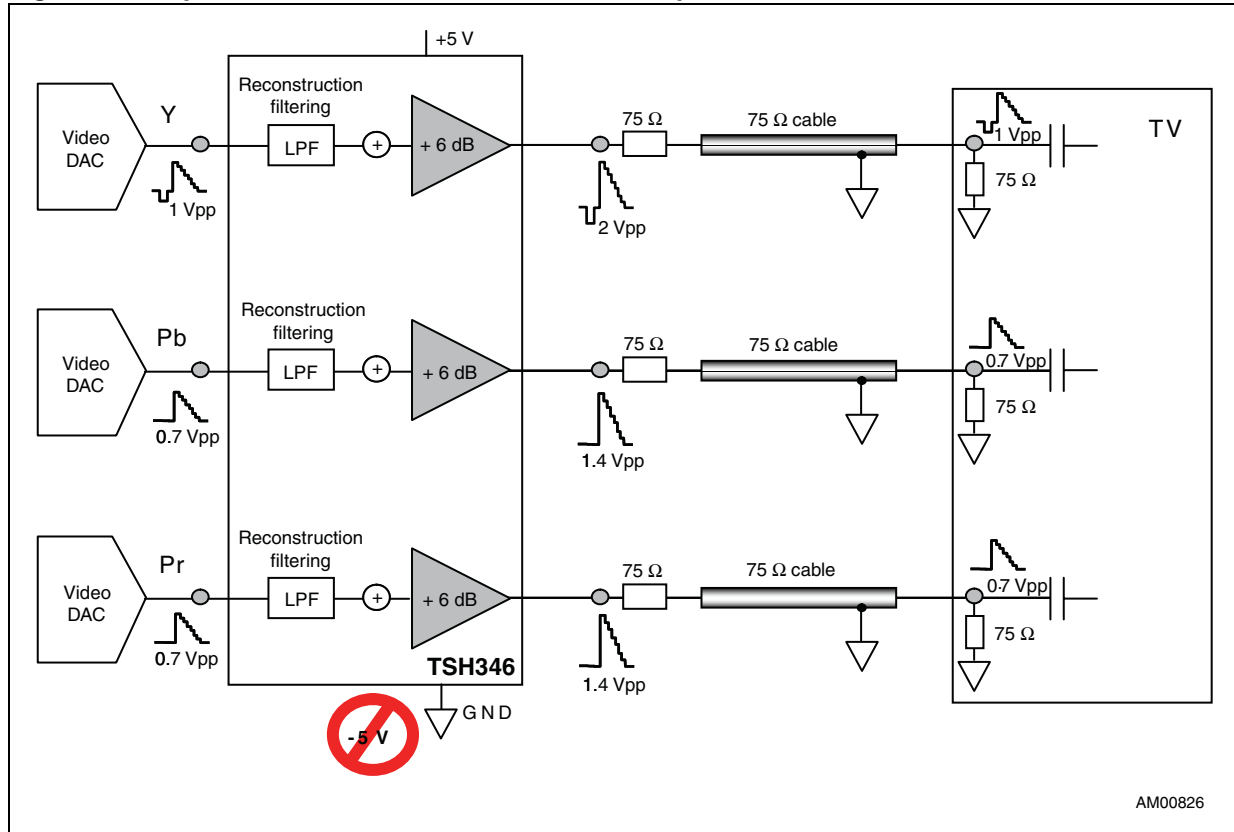
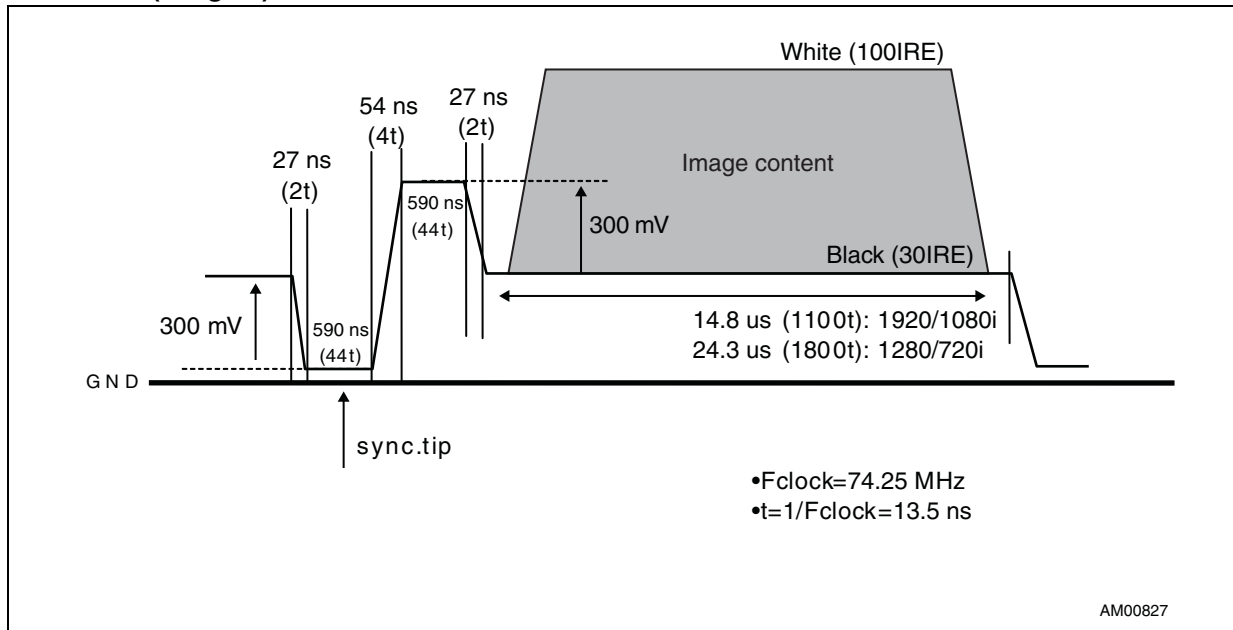

Figure 25. Shapes of HD video signals coming from DACs including the synchronization tip (Y signal)



The TSH346 is used to drive high definition video signals up to 30 MHz. It can drive components such as YPbPr and RGB where the bottom of the signal is close to zero volts. An internal input DC value is added to the video signal in order to shift the bottom from GND.

The shift is not based on the average of the signal, but is an analog summation of a DC component to the video signal. Therefore, no input capacitors are required. This provides a real advantage in terms of cost and board space.

Under these conditions, it is possible to drive the signal in single supply with no saturation of the driver against the lower rail.

Because half of the signal is lost through output impedance matching, in order to correctly drive the video line the shifted signal is multiplied by a gain of +2 or +6 dB.

Figure 26. Flexible solution for SD and HD signals

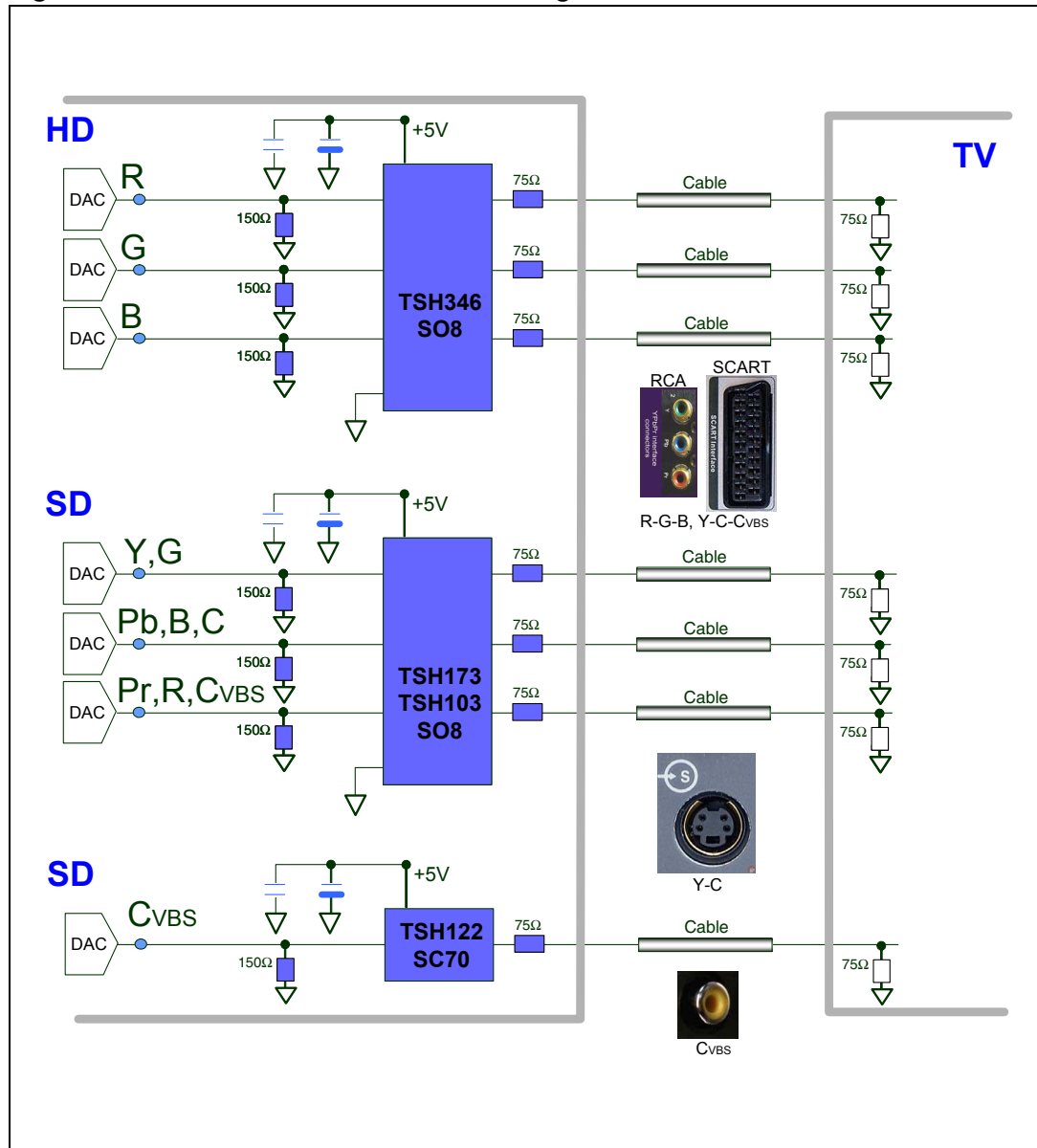

4.1 Output capacitor

The output can be either DC- or AC-coupled, and can be directly connected to the line via a 75- Ω resistor (4) (*Figure 27*). Alternatively, an output capacitor can be used to remove any DC components in the load. Assuming a 150- Ω load, a coupling capacitor of 220 μF can be used to provide a very low cut-off frequency close to 5 Hz (*Figure 28*).

Figure 27. IDC output coupling (1 of 3 channels)

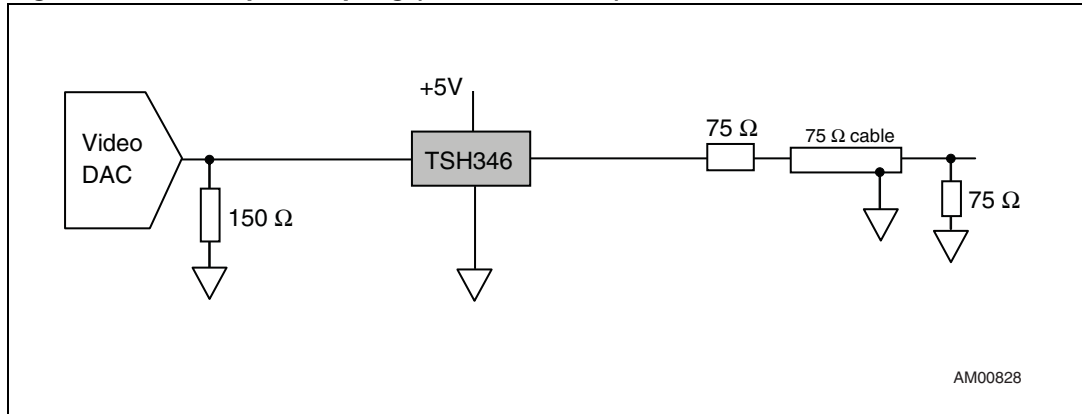
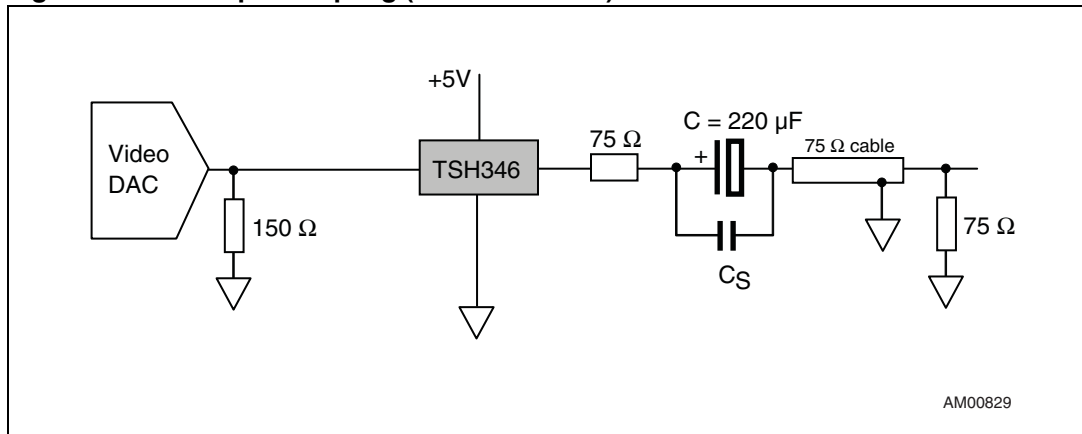

Figure 28. AC output coupling (1 of 3 channels)



1. C_S is a 100 nF used to decrease the parasitic components of C in high frequencies.
2. The 75- Ω resistor must be as close as possible to the output of the driver to minimize the effect of parasitic capacitance.

5 Package information

In order to meet environmental requirements, ST offers these devices in different grades of ECOPACK[®] packages, depending on their level of environmental compliance. ECOPACK[®] specifications, grade definitions and product status are available at: www.st.com. ECOPACK[®] is an ST trademark.

Figure 29. SO-8 package mechanical drawing

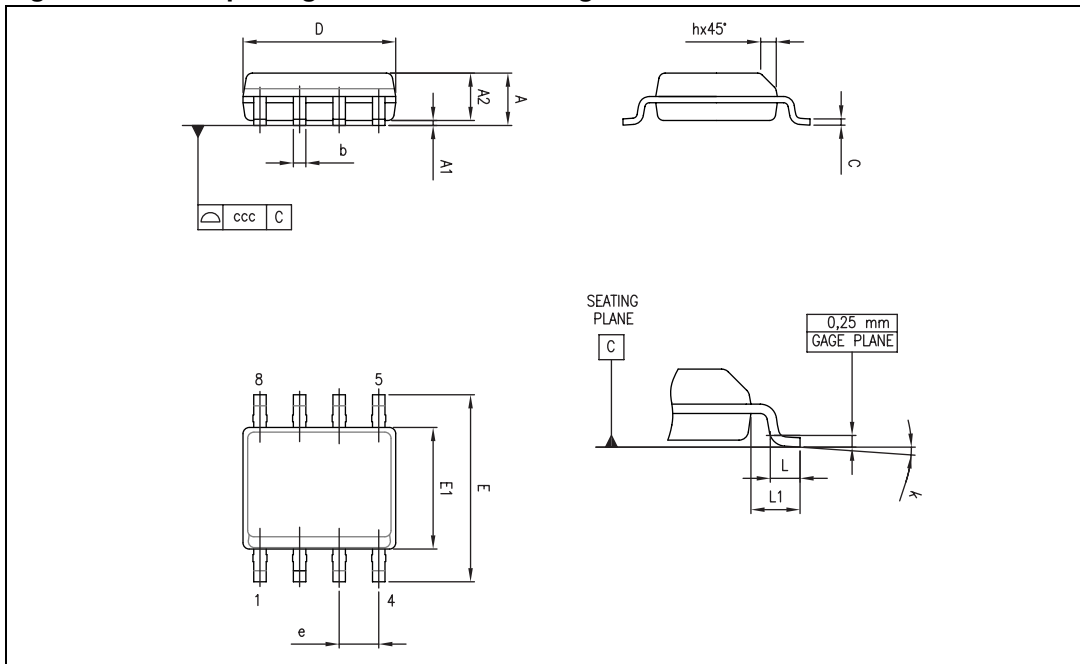

Table 4. SO-8 package mechanical data

Ref.	Dimensions					
	Millimeters			Inches		
	Min.	Typ.	Max.	Min.	Typ.	Max.
A			1.75			0.069
A1	0.10		0.25	0.004		0.010
A2	1.25			0.049		
b	0.28		0.48	0.011		0.019
c	0.17		0.23	0.007		0.010
D	4.80	4.90	5.00	0.189	0.193	0.197
E	5.80	6.00	6.20	0.228	0.236	0.244
E1	3.80	3.90	4.00	0.150	0.154	0.157
e		1.27			0.050	
h	0.25		0.50	0.010		0.020
L	0.40		1.27	0.016		0.050
L1		1.04			0.040	
k	0		8°	1°		8°
ccc			0.10			0.004

6 Ordering information

Table 5. Order codes

Part number	Temperature range	Package	Packing	Marking
TSH346ID	-40°C to +85°C	SO-8	Tube	TSH346I
TSH346IDT			Tape & reel	TSH346I

7 Revision history

Table 6. Document revision history

Date	Revision	Changes
29-May-2007	1	Initial release.
16-Dec-2008	2	Added curves in Chapter 2: Electrical characteristics . Added all test limits in Table 3 .

Please Read Carefully:

Information in this document is provided solely in connection with ST products. STMicroelectronics NV and its subsidiaries ("ST") reserve the right to make changes, corrections, modifications or improvements, to this document, and the products and services described herein at any time, without notice.

All ST products are sold pursuant to ST's terms and conditions of sale.

Purchasers are solely responsible for the choice, selection and use of the ST products and services described herein, and ST assumes no liability whatsoever relating to the choice, selection or use of the ST products and services described herein.

No license, express or implied, by estoppel or otherwise, to any intellectual property rights is granted under this document. If any part of this document refers to any third party products or services it shall not be deemed a license grant by ST for the use of such third party products or services, or any intellectual property contained therein or considered as a warranty covering the use in any manner whatsoever of such third party products or services or any intellectual property contained therein.

UNLESS OTHERWISE SET FORTH IN ST'S TERMS AND CONDITIONS OF SALE ST DISCLAIMS ANY EXPRESS OR IMPLIED WARRANTY WITH RESPECT TO THE USE AND/OR SALE OF ST PRODUCTS INCLUDING WITHOUT LIMITATION IMPLIED WARRANTIES OF MERCHANTABILITY, FITNESS FOR A PARTICULAR PURPOSE (AND THEIR EQUIVALENTS UNDER THE LAWS OF ANY JURISDICTION), OR INFRINGEMENT OF ANY PATENT, COPYRIGHT OR OTHER INTELLECTUAL PROPERTY RIGHT.

UNLESS EXPRESSLY APPROVED IN WRITING BY AN AUTHORIZED ST REPRESENTATIVE, ST PRODUCTS ARE NOT RECOMMENDED, AUTHORIZED OR WARRANTED FOR USE IN MILITARY, AIR CRAFT, SPACE, LIFE SAVING, OR LIFE SUSTAINING APPLICATIONS, NOR IN PRODUCTS OR SYSTEMS WHERE FAILURE OR MALFUNCTION MAY RESULT IN PERSONAL INJURY, DEATH, OR SEVERE PROPERTY OR ENVIRONMENTAL DAMAGE. ST PRODUCTS WHICH ARE NOT SPECIFIED AS "AUTOMOTIVE GRADE" MAY ONLY BE USED IN AUTOMOTIVE APPLICATIONS AT USER'S OWN RISK.

Resale of ST products with provisions different from the statements and/or technical features set forth in this document shall immediately void any warranty granted by ST for the ST product or service described herein and shall not create or extend in any manner whatsoever, any liability of ST.

ST and the ST logo are trademarks or registered trademarks of ST in various countries.

Information in this document supersedes and replaces all information previously supplied.

The ST logo is a registered trademark of STMicroelectronics. All other names are the property of their respective owners.

© 2008 STMicroelectronics - All rights reserved

STMicroelectronics group of companies

Australia - Belgium - Brazil - Canada - China - Czech Republic - Finland - France - Germany - Hong Kong - India - Israel - Italy - Japan - Malaysia - Malta - Morocco - Singapore - Spain - Sweden - Switzerland - United Kingdom - United States of America

www.st.com