



# TSH70,71,72,73,74,75

## Rail-to-Rail, Wide-Band, Low-Power Operational Amplifiers

- 3V, 5V,  $\pm 5V$  specifications
- 3dB bandwidth: 90MHz
- Gain bandwidth product: 70MHz
- Slew rate: 100V/ms
- Output current: up to 55mA
- Input single supply voltage
- Output rail-to-rail
- Specified for 150 $\Omega$  loads
- Low distortion, THD: 0.1%
- SOT23-5, TSSOP and SO packages

### Description

The TSH7x series offers single, dual, triple and quad operational amplifiers featuring high video performances with large bandwidth, low distortion and excellent supply voltage rejection.

Running with a single supply voltage from 3V to 12V, these amplifiers feature a large output voltage swing and high output current capable of driving standard 150 $\Omega$  loads. A low operating voltage makes TSH7x amplifiers ideal for use in portable equipment.

The TSH71, TSH73 and TSH75 also feature standby inputs, each of which allows the op-amp to be put into a standby mode with low power consumption and high output impedance. This function allows power saving or signal switching/multiplexing for high-speed applications and video applications.

To economize both board space and weight, the TSH7x series is proposed in SOT23-5, TSSOP and SO packages.

### Applications

- Video buffers
- ADC driver
- Hi-fi applications

### Pin Connections (top view)

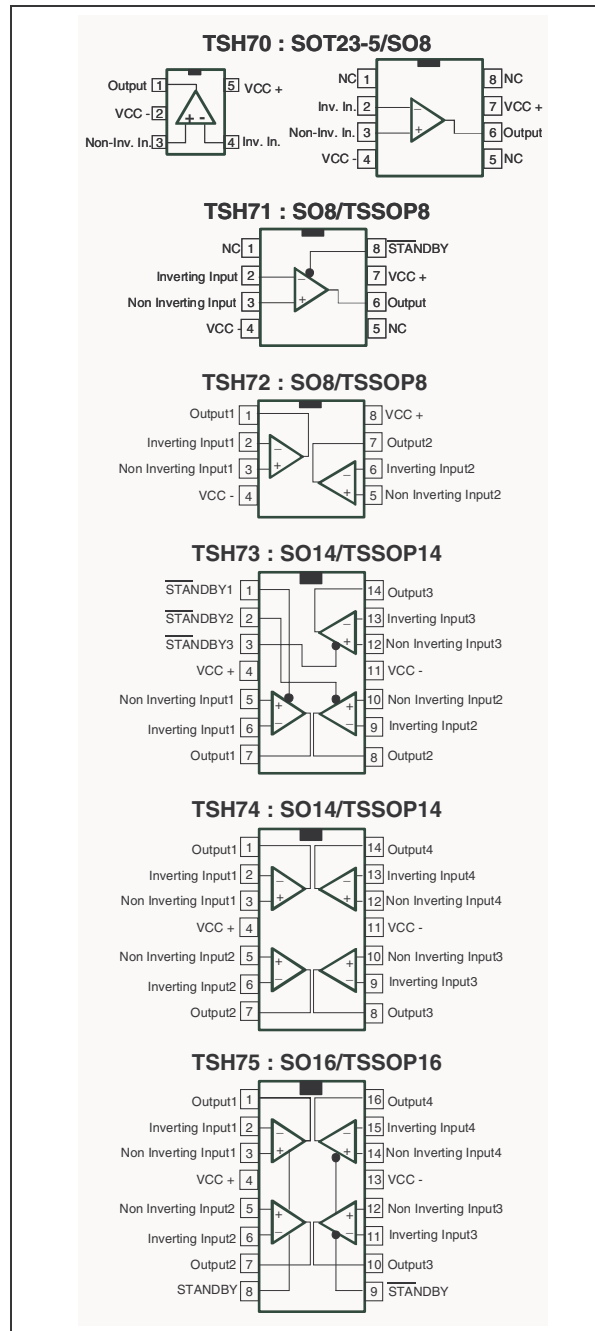

# 1 Order Codes

Part Number	Temperature Range	Package	Packing	Marking
TSH70CLT	0°C to 70°C	SOT23-5	Tape & Reel	K301
TSH70CD/CDT		SO-8	Tube or Tape & Reel	70C
TSH71CD/CDT		SO-8	Tube or Tape & Reel	71C
TSH71CPT		TSSOP8 (Thin Shrink Outline Package)	Tape & Reel	71C
TSH72CD/CDT		SO-8	Tube or Tape & Reel	72C
TSH72CPT		TSSOP8 (Thin Shrink Outline Package)	Tape & Reel	72C
TSH73CD/CDT		SO-14	Tube or Tape & Reel	73C
TSH73CPT		TSSOP14 (Thin Shrink Outline Package)	Tape & Reel	73C
TSH74CD/CDT		SO-14	Tube or Tape & Reel	74C
TSH74CPT		TSSOP14 (Thin Shrink Outline Package)	Tape & Reel	74C
TSH75CD/CDT		SO-16	Tube or Tape & Reel	75C
TSH75CPT		TSSOP16 (Thin Shrink Outline Package)	Tape & Reel	75C

## 2 Typical Application: Video Driver

A typical application for the TSH7x family is that of video driver for driving STi7xxx DAC outputs on 75-ohm lines.

Figure 1 show the benefits of the TSH7x family as single supply drivers.

Figure 1. Benefits of TSH7x family: +3V or +5V single supply solution

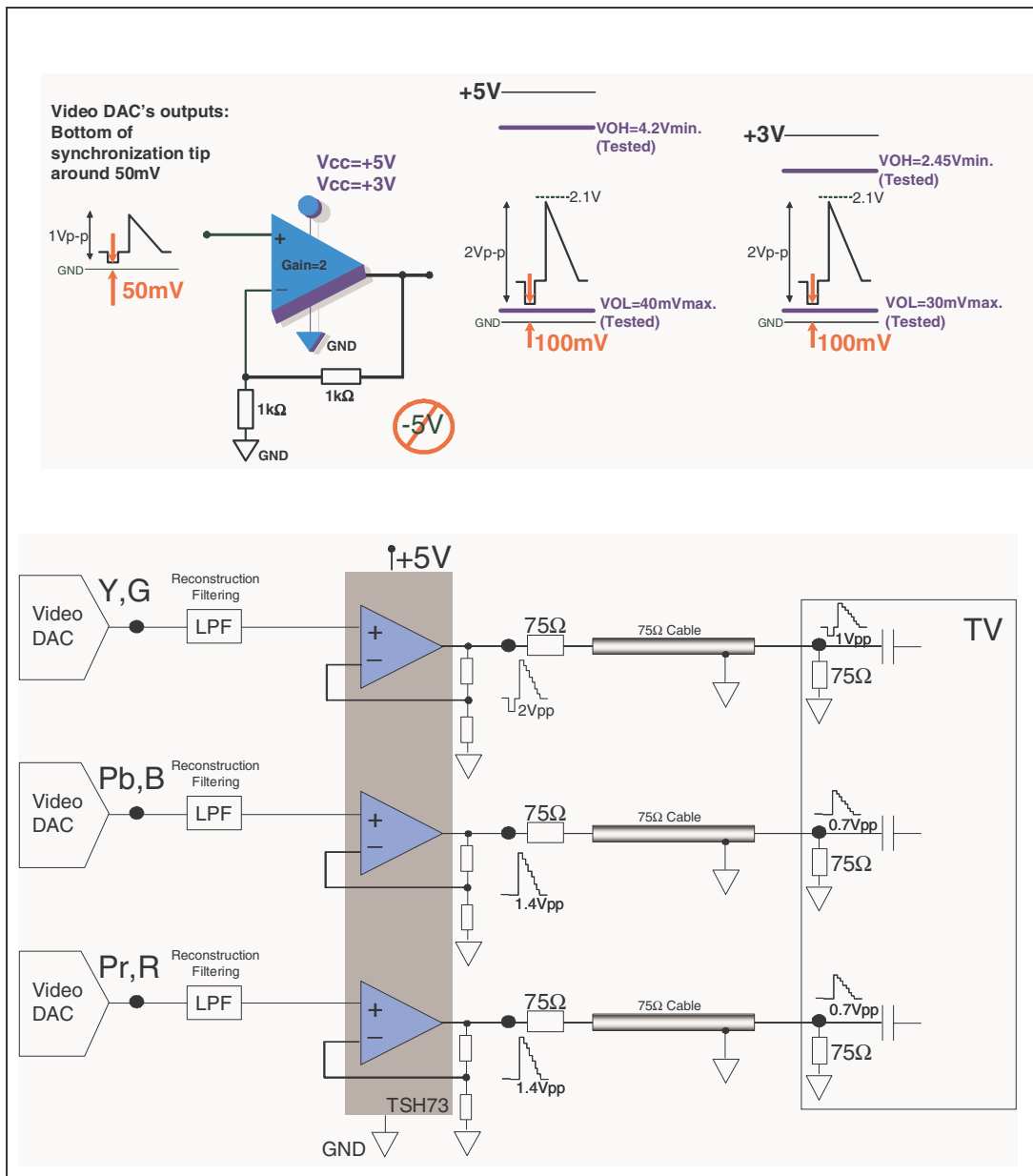

### 3 Absolute Maximum Ratings & Operating Conditions

**Table 1. Absolute maximum ratings (AMR)**

Symbol	Parameter	Value	Unit
$V_{CC}$	Supply Voltage <sup>(1)</sup>	14	V
$V_{id}$	Differential Input Voltage <sup>(2)</sup>	±2	V
$V_i$	Input Voltage <sup>(3)</sup>	±6	V
$T_{oper}$	Operating Free Air Temperature Range	0 to +70	°C
$T_{stg}$	Storage Temperature	-65 to +150	°C
$T_j$	Maximum Junction Temperature	150	°C
$R_{thjc}$	Thermal resistance junction to case <sup>(4)</sup>		
	SOT23-5	80	°C/W
	SO-8	28	
	SO-14	22	
	SO-16	35	
	TSSOP08	37	
	TSSOP14	32	
TSSOP16	35		
$R_{thja}$	Thermal resistance junction to ambient area		
	SOT23-5	250	°C/W
	SO-8	157	
	SO-14	125	
	SO-16	110	
	TSSOP08	130	
	TSSOP14	110	
TSSOP16	110		
ESD	Human Body Model	2	kV

1. All voltages values, except differential voltage are with respect to network ground terminal
2. Differential voltages are non-inverting input terminal with respect to the inverting terminal
3. The magnitude of input and output must never exceed  $V_{CC} + 0.3V$
4. Short-circuits can cause excessive heating

**Table 2. Operating conditions**

Symbol	Parameter	Value	Unit
$V_{CC}$	Supply Voltage	3 to 12	V
$V_{IC}$	Common Mode Input Voltage Range	$V_{CC}^-$ to $(V_{CC}^+ - 1.1)$	V
Standby		$(V_{CC}^-)$ to $(V_{CC}^+)$	V

## 4 Electrical Characteristics

**Table 3.**  $V_{CC^+} = 3V$ ,  $V_{CC^-} = GND$ ,  $V_{IC} = 1.5V$ ,  $T_{amb} = 25^{\circ}C$  (unless otherwise specified)

Symbol	Parameter	Test Conditions	Min.	Typ.	Max.	Unit
$ V_{io} $	Input Offset Voltage	$T_{amb} = 25^{\circ}C$ $T_{min.} < T_{amb} < T_{max.}$		1.2	10 12	mV
$\Delta V_{io}$	Input Offset Voltage Drift vs. Temp.	$T_{min.} < T_{amb} < T_{max.}$		4		$\mu V/^{\circ}C$
$I_{io}$	Input Offset Current	$T_{amb} = 25^{\circ}C$ $T_{min.} < T_{amb} < T_{max.}$		0.1	3.5 5	$\mu A$
$I_{ib}$	Input Bias Current	$T_{amb} = 25^{\circ}C$ $T_{min.} < T_{amb} < T_{max.}$		6	15 20	$\mu A$
$C_{in}$	Input Capacitance			0.2		pF
$I_{CC}$	Supply Current per Operator	$T_{amb} = 25^{\circ}C$ $T_{min.} < T_{amb} < T_{max.}$		7.2	9.8 11	mA
CMRR	Common Mode Rejection Ratio ( $\delta V_{IC}/\delta V_{io}$ )	$+0.1 < V_{IC} < +1.9V$ & $V_{out}=1.5V$ $T_{amb} = 25^{\circ}C$ $T_{min.} < T_{amb} < T_{max.}$	65 64	90		dB
SVRR	Supply Voltage Rejection Ratio ( $\delta V_{CC}/\delta V_{io}$ )	$T_{amb} = 25^{\circ}C$ $T_{min.} < T_{amb} < T_{max.}$	66 65	74		dB
PSRR	Power Supply Rejection Ratio ( $\delta V_{CC}/\delta V_{out}$ )	Positive & Negative Rail		75		dB
$A_{vd}$	Large Signal Voltage Gain	$R_L=150\Omega$ to 1.5V, $V_{out}=1V$ to 2V $T_{amb} = 25^{\circ}C$ $T_{min.} < T_{amb} < T_{max.}$	70 65	81		dB
$I_o$	Output Short Circuit Current Source	$T_{amb}=25^{\circ}C$ , $V_{id}=+1$ , $V_{out}$ to 1.5V, $V_{id}=-1$ , $V_{out}$ to 1.5V $I_{Source}$ $I_{Sink}$ $T_{min.} < T_{amb} < T_{max.}$ $V_{id}=+1$ , $V_{out}$ to 1.5V $V_{id}=-1$ , $V_{out}$ to 1.5V $I_{Source}$ $I_{Sink}$	30 20  22 19	43 33		mA
$V_{OH}$	High Level Output Voltage	$T_{amb}=25^{\circ}C$ $R_L = 150\Omega$ to GND $R_L = 600\Omega$ to GND $R_L = 2k\Omega$ to GND $R_L = 10k\Omega$ to GND  $R_L = 150\Omega$ to 1.5V $R_L = 600\Omega$ to 1.5V $R_L = 2k\Omega$ to 1.5V $R_L = 10k\Omega$ to 1.5V  $T_{min.} < T_{amb} < T_{max.}$ $R_L = 150\Omega$ to GND $R_L = 150\Omega$ to 1.5V	2.45     2.65   2.4 2.6	2.60 2.87 2.91 2.93  2.77 2.90 2.92 2.93		V

**Table 3.**  $V_{CC}^+ = 3V, V_{CC}^- = GND, V_{IC} = 1.5V, T_{amb} = 25^\circ C$  (unless otherwise specified)

Symbol	Parameter	Test Conditions	Min.	Typ.	Max.	Unit
$V_{OL}$	Low Level Output Voltage	$T_{amb}=25^\circ C$ $R_L = 150\Omega$ to GND $R_L = 600\Omega$ to GND $R_L = 2k\Omega$ to GND $R_L = 10k\Omega$ to GND  $R_L = 150\Omega$ to 1.5V $R_L = 600\Omega$ to 1.5V $R_L = 2k\Omega$ to 1.5V $R_L = 10k\Omega$ to 1.5V  $T_{min.} < T_{amb} < T_{max.}$ $R_L = 150\Omega$ to GND $R_L = 150\Omega$ to 1.5V		10 11 11 11  140 90 68 57	30     300      40 350	mV
GBP	Gain Bandwidth Product	$F=10MHz$ $A_{VCL}=+11$ $A_{VCL}=-10$		65 55		MHz
Bw	Bandwidth @-3dB	$A_{VCL}=+1, R_L=150\Omega$ to 1.5V		87		MHz
SR	Slew Rate	$A_{VCL}=+2, R_L=150\Omega // C_L$ to 1.5V $C_L = 5pF$ $C_L = 30pF$	45	80 85		V/ $\mu s$
$\phi_m$	Phase Margin	$R_L=150\Omega // 30pF$ to 1.5V		40		$^\circ$
en	Equivalent Input Noise Voltage	$F=100kHz$		11		nV/ $\sqrt{Hz}$
THD	Total Harmonic Distortion	$A_{VCL}=+2, F=4MHz, R_L=150\Omega // 30pF$ to 1.5V $V_{out}=1V_{pp}$ $V_{out}=2V_{pp}$		-61 -54		dB
IM2	Second order intermodulation product	$A_{VCL}=+2, V_{out}=2V_{pp}$ $R_L=150\Omega$ to 1.5V $Fin1=180kHz, Fin2=280kHz$ spurious measurements @100kHz		-76		dBc
IM3	Third order inter modulation product	$A_{VCL}=+2, V_{out}=2V_{pp}$ $R_L=150\Omega$ to 1.5V $Fin1=180kHz, Fin2=280kHz$ spurious measurements @400kHz		-68		dBc
$\Delta G$	Differential gain	$A_{VCL}=+2, R_L=150\Omega$ to 1.5V $F=4.5MHz, V_{out}=2V_{pp}$		0.5		%
Df	Differential phase	$A_{VCL}=+2, R_L=150\Omega$ to 1.5V $F=4.5MHz, V_{out}=2V_{pp}$		0.5		$^\circ$
Gf	Gain Flatness	$F=DC$ to 6MHz, $A_{VCL}=+2$		0.2		dB
Vo1/Vo2	Channel Separation	$F=1MHz$ to 10MHz		65		dB

Table 4.  $V_{CC}^+ = 5V$ ,  $V_{CC}^- = GND$ ,  $V_{IC} = 2.5V$ ,  $T_{amb} = 25^\circ C$  (unless otherwise specified)

Symbol	Parameter	Test Conditions	Min.	Typ.	Max.	Unit
$ V_{io} $	Input Offset Voltage	$T_{amb} = 25^\circ C$ $T_{min.} < T_{amb} < T_{max.}$		1.1	10 12	mV
$\Delta V_{io}$	Input Offset Voltage Drift vs. Temp.	$T_{min.} < T_{amb} < T_{max.}$		3		$\mu V/^\circ C$
$I_{io}$	Input Offset Current	$T_{amb} = 25^\circ C$ $T_{min.} < T_{amb} < T_{max.}$		0.1	3.5 5	$\mu A$
$I_{ib}$	Input Bias Current	$T_{amb} = 25^\circ C$ $T_{min.} < T_{amb} < T_{max.}$		6	15 20	$\mu A$
$C_{in}$	Input Capacitance			0.3		pF
$I_{CC}$	Supply Current per Operator	$T_{amb} = 25^\circ C$ $T_{min.} < T_{amb} < T_{max.}$		8.2	10.5 11.5	mA
CMRR	Common Mode Rejection Ratio ( $\delta V_{IC}/\delta V_{io}$ )	$+0.1 < V_{IC} < 3.9V$ & $V_{out}=2.5V$ $T_{amb} = 25^\circ C$ $T_{min.} < T_{amb} < T_{max.}$	72 71	97		dB
SVRR	Supply Voltage Rejection Ratio ( $\delta V_{CC}/\delta V_{io}$ )	$T_{amb} = 25^\circ C$ $T_{min.} < T_{amb} < T_{max.}$	68 67	75		dB
PSRR	Power Supply Rejection Ratio ( $\delta V_{CC}/\delta V_{out}$ )	Positive & Negative Rail		75		dB
$A_{vd}$	Large Signal Voltage Gain	$R_L = 150\Omega$ to 1.5V, $V_{out}=1V$ to 4V $T_{amb} = 25^\circ C$ $T_{min.} < T_{amb} < T_{max.}$	75 70	84		dB
$I_o$	Output Short Circuit Current Source	$T_{amb}=25^\circ C$ , $V_{id}=+1, V_{out}$ to 1.5V, $V_{id}=-1, V_{out}$ to 1.5V $I_{Source}$ $I_{Sink}$ $T_{min.} < T_{amb} < T_{max.}$ $V_{id}=+1, V_{out}$ to 1.5V $V_{id}=-1, V_{out}$ to 1.5V $I_{Source}$ $I_{Sink}$	35 33  34 32	55 55		mA
$V_{OH}$	High Level Output Voltage	$T_{amb}=25^\circ C$ $R_L = 150\Omega$ to GND $R_L = 600\Omega$ to GND $R_L = 2k\Omega$ to GND $R_L = 10k\Omega$ to GND  $R_L = 150\Omega$ to 2.5V $R_L = 600\Omega$ to 2.5V $R_L = 2k\Omega$ to 2.5V $R_L = 10k\Omega$ to 2.5V  $T_{min.} < T_{amb} < T_{max.}$ $R_L = 150\Omega$ to GND $R_L = 150\Omega$ to 2.5V	4.2     4.5   4.1 4.4	4.36 4.85 4.90 4.93  4.66 4.90 4.92 4.93		V

Table 4.  $V_{CC}^+ = 5V$ ,  $V_{CC}^- = GND$ ,  $V_{IC} = 2.5V$ ,  $T_{amb} = 25^\circ C$  (unless otherwise specified)

Symbol	Parameter	Test Conditions	Min.	Typ.	Max.	Unit
$V_{OL}$	Low Level Output Voltage	$T_{amb}=25^\circ C$ $R_L = 150\Omega$ to GND $R_L = 600\Omega$ to GND $R_L = 2k\Omega$ to GND $R_L = 10k\Omega$ to GND  $R_L = 150\Omega$ to 2.5V $R_L = 600\Omega$ to 2.5V $R_L = 2k\Omega$ to 2.5V $R_L = 10k\Omega$ to 2.5V  $T_{min.} < T_{amb} < T_{max.}$ $R_L = 150\Omega$ to GND $R_L = 150\Omega$ to 2.5V		20 23 23 23  220 105 76 61	40     400      60 450	mV
GBP	Gain Bandwidth Product	$F=10MHz$ $A_{VCL}=+11$ $A_{VCL}=-10$		65 55		MHz
Bw	Bandwidth @-3dB	$A_{VCL}=+1$ , $R_L=150\Omega$ to 2.5V		87		MHz
SR	Slew Rate	$A_{VCL}=+2$ , $R_L=150\Omega // C_L$ to 2.5V $C_L = 5pF$ $C_L = 30pF$	60	104 105		V/ $\mu s$
$\phi_m$	Phase Margin	$R_L=150\Omega // 30pF$ to 2.5V		40		$^\circ$
en	Equivalent Input Noise Voltage	$F=100kHz$		11		nV/ $\sqrt{Hz}$
THD	Total Harmonic Distortion	$A_{VCL}=+2$ , $F=4MHz$ $R_L=150\Omega // 30pF$ to 2.5V $V_{out}=1V_{pp}$ $V_{out}=2V_{pp}$		-61 -54		dB
IM2	Second order intermodulation product	$A_{VCL}=+2$ , $V_{out}=2V_{pp}$ $R_L=150\Omega$ to 2.5V $Fin1=180kHz$ , $Fin2=280kHz$ spurious measurements @100kHz		-76		dBc
IM3	Third order inter modulation product	$A_{VCL}=+2$ , $V_{out}=2V_{pp}$ $R_L=150\Omega$ to 2.5V $Fin1=180kHz$ , $Fin2=280kHz$ spurious measurements @400kHz		-68		dBc
$\Delta G$	Differential gain	$A_{VCL}=+2$ , $R_L=150\Omega$ to 2.5V $F=4.5MHz$ , $V_{out}=2V_{pp}$		0.5		%
Df	Differential phase	$A_{VCL}=+2$ , $R_L=150\Omega$ to 2.5V $F=4.5MHz$ , $V_{out}=2V_{pp}$		0.5		$^\circ$
Gf	Gain Flatness	$F=DC$ to 6MHz, $A_{VCL}=+2$		0.2		dB
Vo1/Vo2	Channel Separation	$F=1MHz$ to 10MHz		65		dB

Table 5.  $V_{CC}^+ = 5V$ ,  $V_{CC}^- = -5V$ ,  $V_{IC} = GND$ ,  $T_{amb} = 25^\circ C$  (unless otherwise specified)

Symbol	Parameter	Test Conditions	Min.	Typ.	Max.	Unit
$ V_{io} $	Input Offset Voltage	$T_{amb} = 25^\circ C$ $T_{min.} < T_{amb} < T_{max.}$		0.8	10 12	mV
$\Delta V_{io}$	Input Offset Voltage Drift vs. Temp.	$T_{min.} < T_{amb} < T_{max.}$		2		$\mu V/^\circ C$
$I_{io}$	Input Offset Current	$T_{amb} = 25^\circ C$ $T_{min.} < T_{amb} < T_{max.}$		0.1	3.5 5	$\mu A$
$I_{ib}$	Input Bias Current	$T_{amb} = 25^\circ C$ $T_{min.} < T_{amb} < T_{max.}$		6	15 20	$\mu A$
$C_{in}$	Input Capacitance			0.7		pF
$I_{CC}$	Supply Current per Operator	$T_{amb} = 25^\circ C$ $T_{min.} < T_{amb} < T_{max.}$		9.8	12.3 13.4	mA
CMRR	Common Mode Rejection Ratio ( $\delta V_{IC}/\delta V_{io}$ )	$-4.9 < V_{IC} < 3.9V$ & $V_{out}=GND$ $T_{amb} = 25^\circ C$ $T_{min.} < T_{amb} < T_{max.}$	81 80	106		dB
SVRR	Supply Voltage Rejection Ratio ( $\delta V_{CC}/\delta V_{io}$ )	$T_{amb} = 25^\circ C$ $T_{min.} < T_{amb} < T_{max.}$	71 70	77		dB
PSRR	Power Supply Rejection Ratio ( $\delta V_{CC}/\delta V_{out}$ )	Positive & Negative Rail		75		dB
$A_{vd}$	Large Signal Voltage Gain	$R_L = 150\Omega$ to GND $V_{out} = -4$ to $+4$ $T_{amb} = 25^\circ C$ $T_{min.} < T_{amb} < T_{max.}$	75 70	86		dB
$I_o$	Output Short Circuit Current Source	$T_{amb} = 25^\circ C$ $V_{id} = +1, V_{out}$ to 1.5V $V_{id} = -1, V_{out}$ to 1.5V $I_{Source}$ $I_{Sink}$ $T_{min.} < T_{amb} < T_{max.}$ $V_{id} = +1, V_{out}$ to 1.5V $V_{id} = -1, V_{out}$ to 1.5V $I_{Source}$ $I_{Sink}$	35 30  34 29	55 55		mA
$V_{OH}$	High Level Output Voltage	$T_{amb} = 25^\circ C$ $R_L = 150\Omega$ to GND $R_L = 600\Omega$ to GND $R_L = 2k\Omega$ to GND $R_L = 10k\Omega$ to GND $T_{min.} < T_{amb} < T_{max.}$ $R_L = 150\Omega$ to GND	4.2    4.1	4.36 4.85 4.9 4.93		V
$V_{OL}$	Low Level Output Voltage	$T_{amb} = 25^\circ C$ $R_L = 150\Omega$ to GND $R_L = 600\Omega$ to GND $R_L = 2k\Omega$ to GND $R_L = 10k\Omega$ to GND $T_{min.} < T_{amb} < T_{max.}$ $R_L = 150\Omega$ to GND		-4.63 -4.86 -4.9 -4.93	-4.4   -4.3	V

Table 5.  $V_{CC}^+ = 5V$ ,  $V_{CC}^- = -5V$ ,  $V_{IC} = GND$ ,  $T_{amb} = 25^\circ C$  (unless otherwise specified)

Symbol	Parameter	Test Conditions	Min.	Typ.	Max.	Unit
GBP	Gain Bandwidth Product	F=10MHz $A_{VCL}=+11$ $A_{VCL}=-10$		65 55		MHz
Bw	Bandwidth @-3dB	$A_{VCL}=+1$ $R_L=150\Omega // 30pF$ to GND		100		MHz
SR	Slew Rate	$A_{VCL}=+2$ , $R_L=150\Omega // C_L$ to GND $C_L = 5pF$ $C_L = 30pF$	68	117 118		V/ $\mu$ s
$\phi_m$	Phase Margin	$R_L=150\Omega$ to GND		40		$^\circ$
en	Equivalent Input Noise Voltage	F=100kHz		11		nV/ $\sqrt{Hz}$
THD	Total Harmonic Distortion	$A_{VCL}=+2$ , F=4MHz $R_L=150\Omega // 30pF$ to GND $V_{out}=1V_{pp}$ $V_{out}=2V_{pp}$		-61 -54		dB
IM2	Second order intermodulation product	$A_{VCL}=+2$ , $V_{out}=2V_{pp}$ $R_L=150\Omega$ to GND Fin1=180kHz, Fin2=280kHz spurious measurements @100kHz		-76		dBc
IM3	Third order intermodulation product	$A_{VCL}=+2$ , $V_{out}=2V_{pp}$ $R_L=150\Omega$ to GND Fin1=180kHz, Fin2=280kHz spurious measurements @400kHz		-68		dBc
$\Delta G$	Differential gain	$A_{VCL}=+2$ , $R_L=150\Omega$ to GND F=4.5MHz, $V_{out}=2V_{pp}$		0.5		%
Df	Differential phase	$A_{VCL}=+2$ , $R_L=150\Omega$ to GND F=4.5MHz, $V_{out}=2V_{pp}$		0.5		$^\circ$
Gf	Gain Flatness	F=DC to 6MHz, $A_{VCL}=+2$		0.2		dB
Vo1/Vo2	Channel Separation	F=1MHz to 10MHz		65		dB

### 4.1 Standby mode

Table 6.  $V_{CC}^+$ ,  $V_{CC}^-$ ,  $T_{amb} = 25^\circ\text{C}$  (unless otherwise specified)

Symbol	Parameter	Test Conditions	Min.	Typ.	Max.	Unit
$V_{low}$	Standby Low Level		$V_{CC}^-$		$(V_{CC}^- + 0.8)$	V
$V_{high}$	Standby High Level		$(V_{CC}^- + 2)$		$(V_{CC}^+)$	V
$I_{CC\ STBY}$	Current Consumption per Operator when STANDBY is Active	pin 8 (TSH71) to $V_{CC}^-$ pin 1,2 or 3 (TSH73) to $V_{CC}^-$ pin 8 (TSH75) to $V_{CC}^+$ pin 9 (TSH75) to $V_{CC}^-$		20	55	$\mu\text{A}$
$Z_{out}$	Output Impedance ( $R_{out}/C_{out}$ )	$R_{out}$ $C_{out}$		10 17		M $\Omega$ pF
$T_{on}$	Time from Standby Mode to Active Mode			2		$\mu\text{s}$
$T_{off}$	Time from Active Mode to Standby Mode	Down to $I_{CC\ STBY} = 10\mu\text{A}$		10		$\mu\text{s}$

TSH71 STANDBY CONTROL pin 8 ( $\overline{\text{STBY}}$ )		OPERATOR STATUS	
$V_{low}$		Standby	
$V_{high}$		Active	

TSH73 STANDBY CONTROL			OPERATOR STATUS		
pin 1 ( $\overline{\text{STBY OP1}}$ )	pin 2 ( $\overline{\text{STBY OP2}}$ )	pin 3 ( $\overline{\text{STBY OP3}}$ )	OP1	OP1	OP3
$V_{low}$	x	x	Standby	x	x
$V_{high}$	x	x	Active	x	x
x	$V_{low}$	x	x	Standby	x
x	$V_{high}$		x	Active	x
x	x	$V_{low}$	x	x	Standby
x	x	$V_{high}$	x	x	Active

TSH75 STANDBY CONTROL		OPERATOR STATUS			
pin 8 ( $\overline{\text{STBY OP2}}$ )	pin 9 ( $\overline{\text{STBY OP3}}$ )	OP1	OP2	OP3	OP4
$V_{high}$	$V_{low}$	Active	Standby	Standby	Active
$V_{high}$	$V_{high}$	Active	Standby	Active	Active
$V_{low}$	$V_{low}$	Active	Active	Standby	Active
$V_{low}$	$V_{high}$	Active	Active	Active	Active

### 4.2 Characteristic curves for $V_{CC}=3V$

**Figure 2. Closed loop gain and phase vs. frequency** (Gain = +2,  $V_{CC} = \pm 1.5V$ ,  $R_L = 150\Omega$ ,  $T_{amb} = 25^\circ C$ )

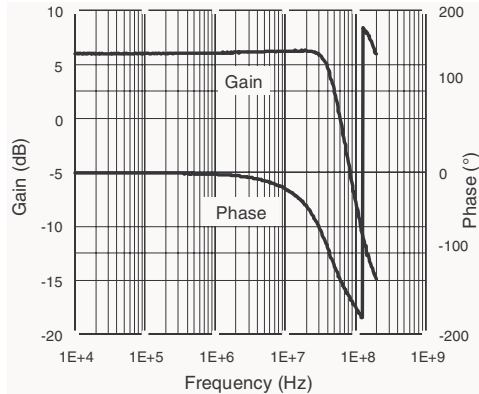

**Figure 3. Overshoot function of output capacitance** (Gain = +2,  $V_{CC} = \pm 1.5V$ ,  $T_{amb} = 25^\circ C$ )

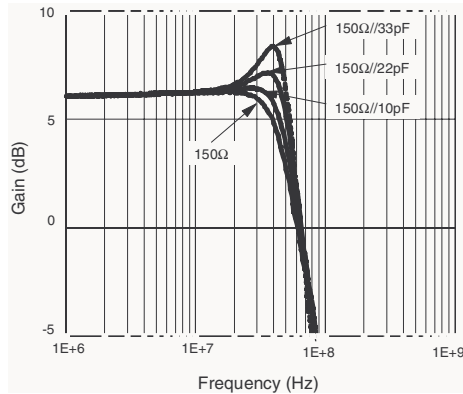

**Figure 4. Closed loop gain and phase vs. frequency** (Gain = -10,  $V_{CC} = \pm 1.5V$ ,  $R_L = 150\Omega$ ,  $T_{amb} = 25^\circ C$ )

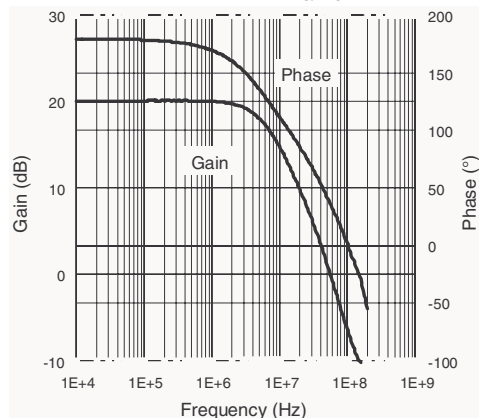

**Figure 5. Closed loop gain and phase vs. frequency** (Gain = +11,  $V_{CC} = \pm 1.5V$ ,  $R_L = 150\Omega$ ,  $T_{amb} = 25^\circ C$ )

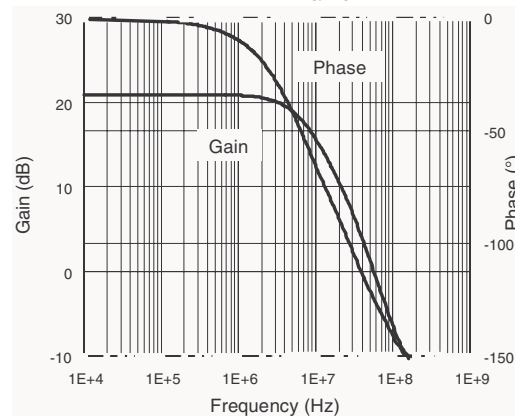

**Figure 6. Large signal measurement - positive slew rate** (Gain = 2,  $V_{CC} = \pm 1.5V$ ,  $Z_L = 150\Omega//5.6pF$ )

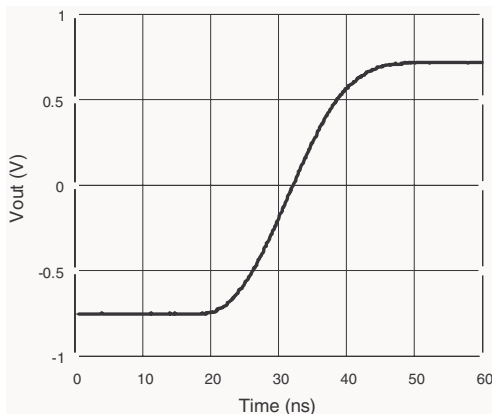

**Figure 7. Large signal measurement - negative slew rate** (Gain = 2,  $V_{CC} = \pm 1.5V$ ,  $Z_L = 150\Omega//5.6pF$ )

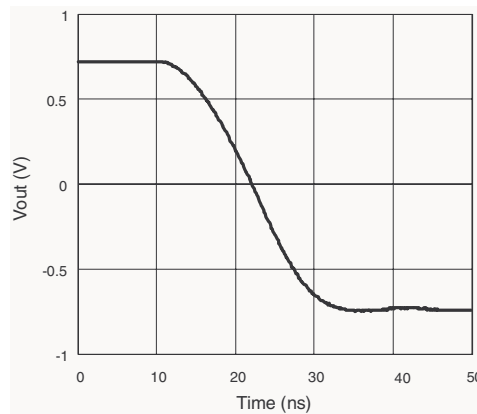

**Figure 8. Small signal measurement - rise time** (Gain = 2,  $V_{CC} = \pm 1.5V$ ,  $Z_L = 150\Omega$ )

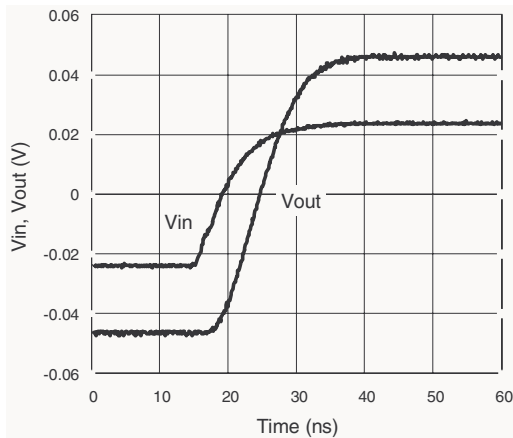

**Figure 9. Small signal measurement - fall time** (Gain = 2,  $V_{CC} = \pm 1.5V$ ,  $Z_L = 150\Omega$ )

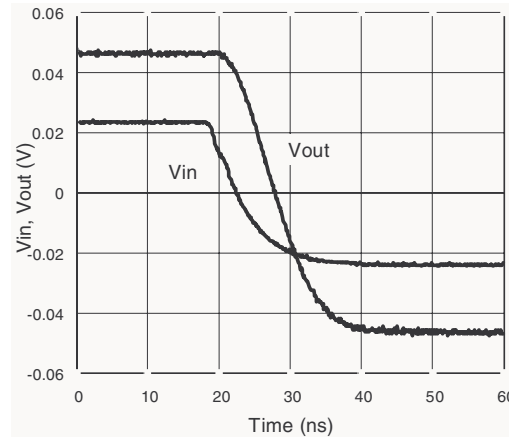

**Figure 10. Channel separation (Xtalk) vs. frequency** (measurement configuration:  $Xtalk = 20\log(V0/V1)$ )

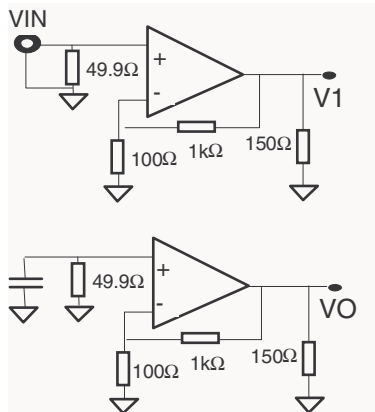

**Figure 11. Channel separation (Xtalk) vs. frequency** (Gain = +11,  $V_{CC} = 1.5V$ ,  $Z_L = 150\Omega//27pF$ )

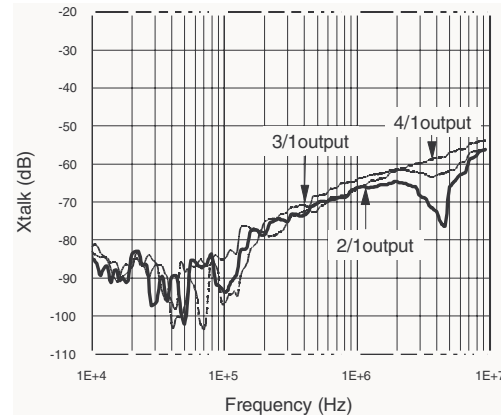

**Figure 12. Equivalent noise voltage** (Gain = 100,  $V_{CC} = \pm 1.5V$ , No load)

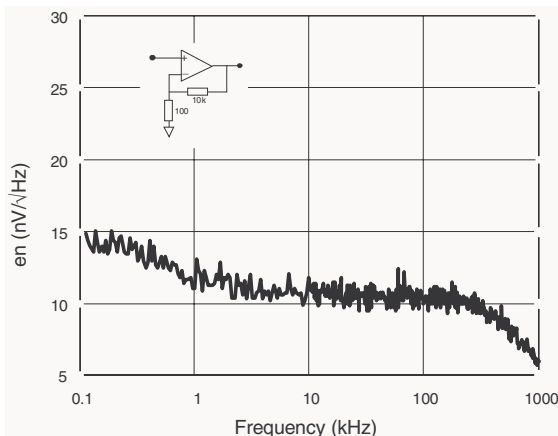

**Figure 13. Maximum output swing** (Gain = 11,  $V_{CC} = \pm 5V$ ,  $R_L = 150\Omega$ )

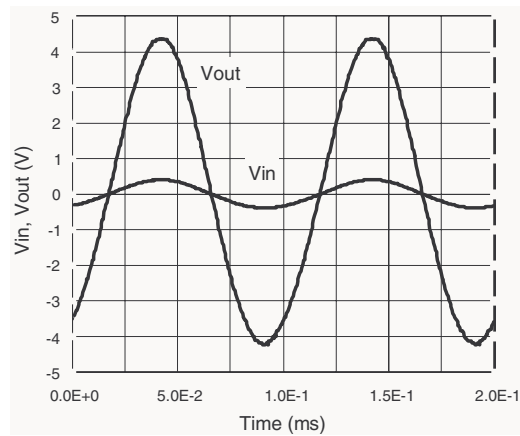

**Figure 14. Standby mode -  $T_{on}$ ,  $T_{off}$**   
( $V_{CC} = \pm 1.5V$ , open loop)

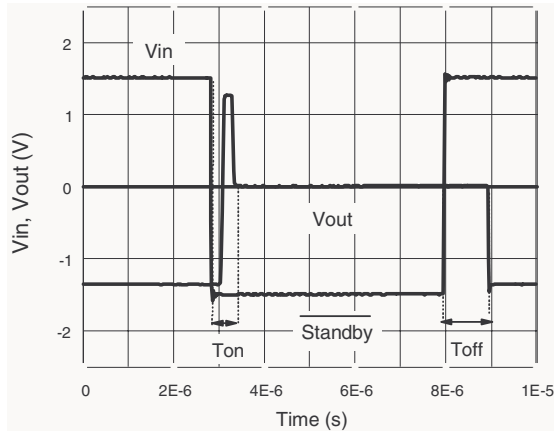

**Figure 15. Group delay gain = 2** ( $V_{CC_0} = \pm 1.5V$ ,  
 $Z_L = 150\Omega // 27pF$ ,  $T_{amb} = 25^\circ C$ )

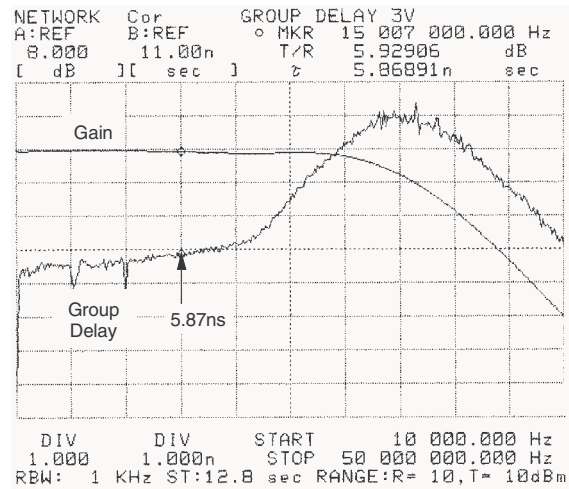

**Figure 16. Third order intermodulation<sup>(1)</sup>**  
(Gain = 2,  $V_{CC} = \pm 1.5V$ ,  
 $Z_L = 150\Omega // 27pF$ ,  $T_{amb} = 25^\circ C$ )

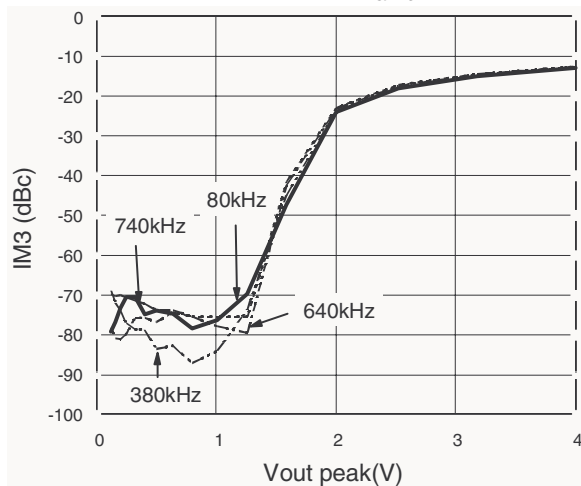

- Note on intermodulation products:  
The IFR2026 synthesizer generates a two tones signal ( $F_1=180kHz$ ,  $F_2=280kHz$ ); each tone having the same amplitude level.  
The HP3585 spectrum analyzer measures the intermodulation products function of the output voltage.  
The generator and the spectrum analyzer are phase locked for precision considerations.

### 4.3 Characteristic curves for $V_{CC}=5V$

**Figure 17. Closed loop gain and phase vs. frequency** (Gain = +2,  $V_{CC} = \pm 2.5V$ ,  $R_L = 150\Omega$ ,  $T_{amb} = 25^\circ C$ )

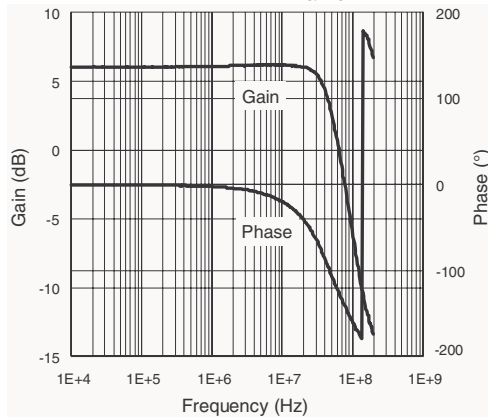

**Figure 18. Overshoot function of output capacitance** (Gain = +2,  $V_{CC} = \pm 2.5V$ ,  $T_{amb} = 25^\circ C$ )

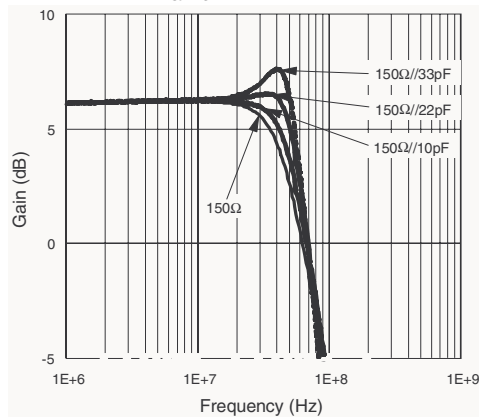

**Figure 19. Closed loop gain and phase vs. frequency** (Gain = -10,  $V_{CC} = \pm 2.5V$ ,  $R_L = 150\Omega$ ,  $T_{amb} = 25^\circ C$ )

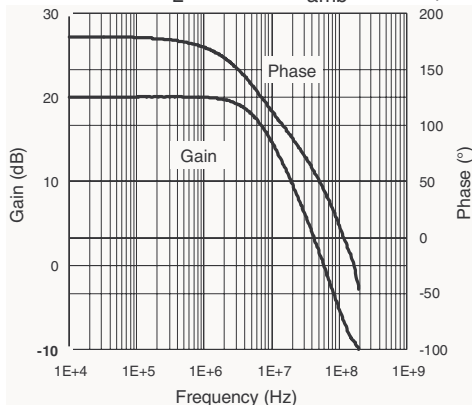

**Figure 20. Closed loop gain and phase vs. frequency** (Gain = +11,  $V_{CC} = \pm 2.5V$ ,  $R_L = 150\Omega$ ,  $T_{amb} = 25^\circ C$ )

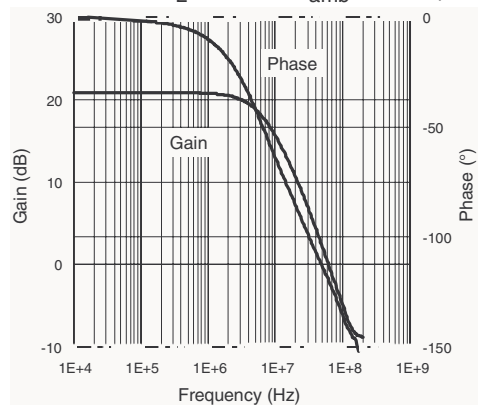

**Figure 21. Large signal measurement - positive slew rate** (Gain = 2,  $V_{CC} = \pm 2.5V$ ,  $Z_L = 150\Omega/5.6pF$ )

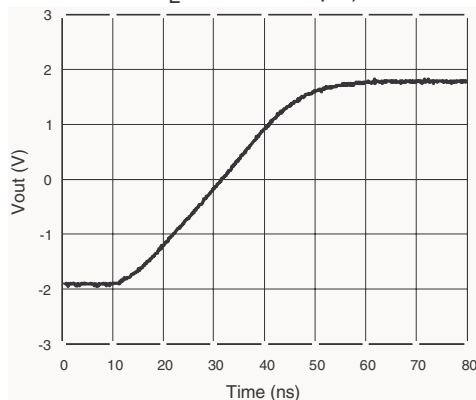

**Figure 22. Large signal measurement - negative slew rate** (Gain = 2,  $V_{CC} = \pm 2.5V$ ,  $Z_L = 150\Omega/5.6pF$ )

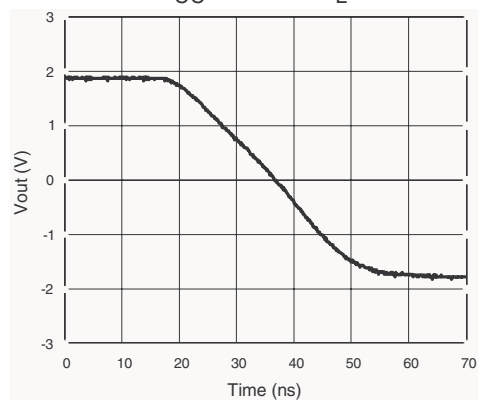

**Figure 23. Small signal measurement - rise time** (Gain = 2,  $V_{CC} = \pm 2.5V$ ,  $Z_L = 150\Omega$ )

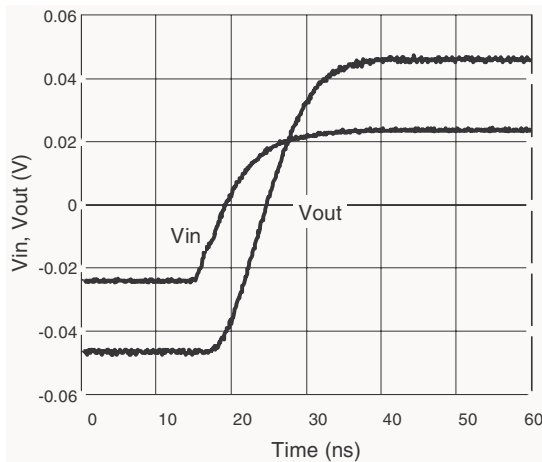

**Figure 24. Small signal measurement - fall time** (Gain = 2,  $V_{CC} = \pm 2.5V$ ,  $Z_L = 150\Omega$ )

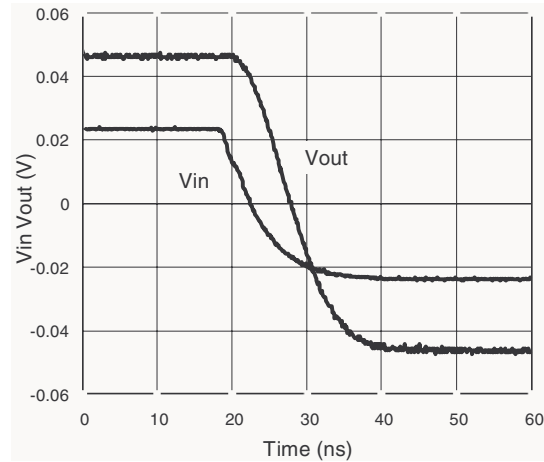

**Figure 25. Channel separation (Xtalk) vs. frequency** (measurement configuration:  $Xtalk = 20\log(V0/V1)$ )

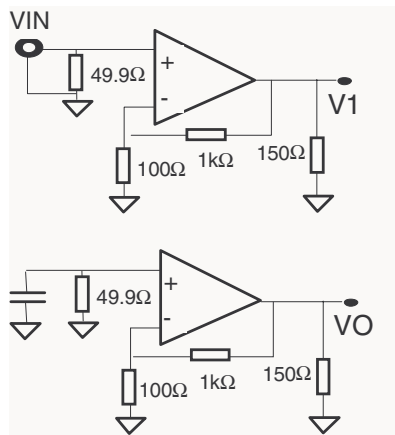

**Figure 26. Channel separation (Xtalk) vs. frequency** (Gain = +11,  $V_{CC} = \pm 2.5V$ ,  $Z_L = 150\Omega//27pF$ )

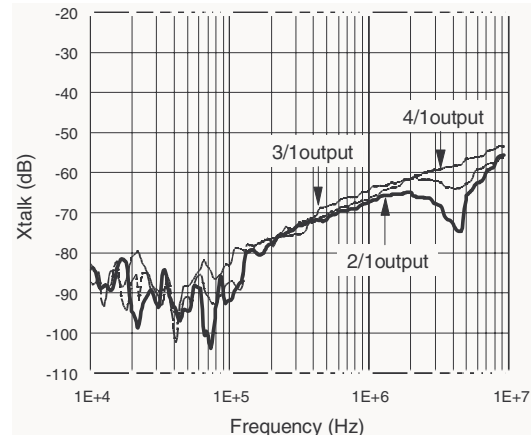

**Figure 27. Equivalent noise voltage** (Gain = 100,  $V_{CC} = \pm 2.5V$ , no load)

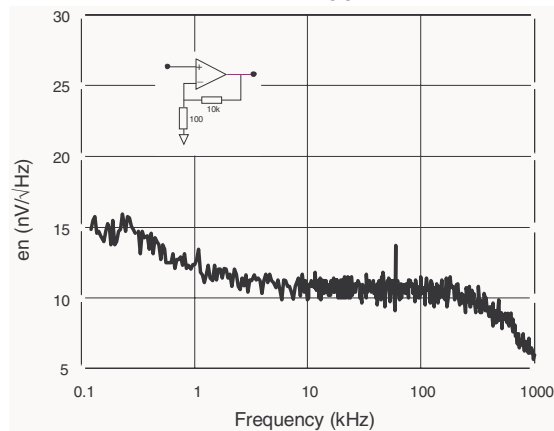

**Figure 28. Maximum output swing** (Gain = 11,  $V_{CC} = \pm 2.5V$ ,  $R_L = 150\Omega$ )

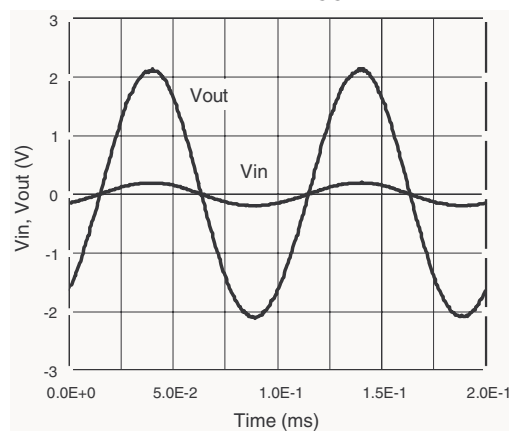

**Figure 29. Standby mode -  $T_{on}$ ,  $T_{off}$**   
 ( $V_{CC} = \pm 2.5V$ , open loop)

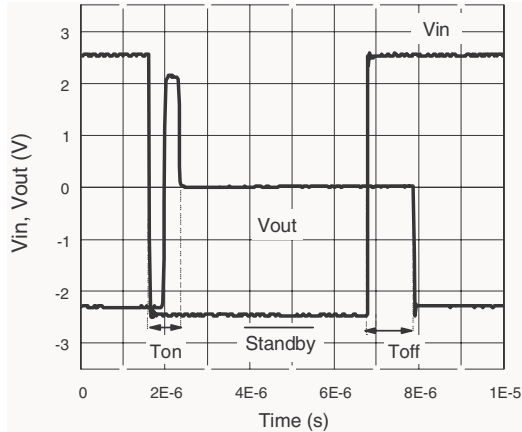

**Figure 30. Group delay (Gain = 2,  $V_{CC} = \pm 2.5V$ ,  
 $Z_L = 150\Omega//27pF$ ,  $T_{amb} = 25^\circ C$ )**

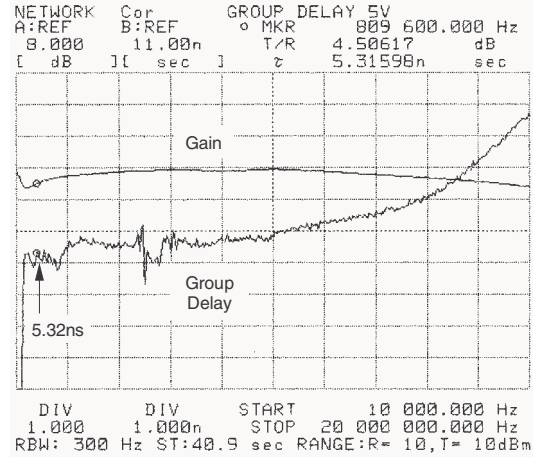

**Figure 31. Third order intermodulation<sup>(1)</sup>**  
 (Gain = 2,  $V_{CC} = \pm 2.5V$ ,  
 $Z_L = 150\Omega//27pF$ ,  $T_{amb} = 25^\circ C$ )

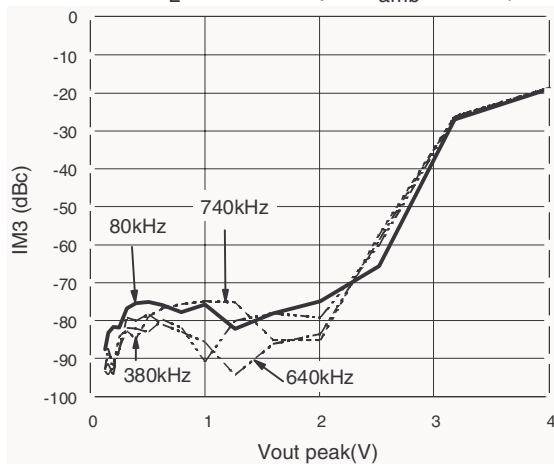

- Note on intermodulation products:  
 The IFR2026 synthesizer generates a two tones signal ( $F1=180kHz$ ,  $F2=280kHz$ ); each tone having the same amplitude level.  
 The HP3585 spectrum analyzer measures the intermodulation products function of the output voltage.  
 The generator and the spectrum analyzer are phase locked for precision considerations.

### 4.4 Characteristic curves for $V_{CC}=10V$

**Figure 32. Closed loop gain and phase vs. frequency** (Gain = +2,  $V_{CC} = \pm 5V$ ,  $R_L = 150\Omega$ ,  $T_{amb} = 25^\circ C$ )

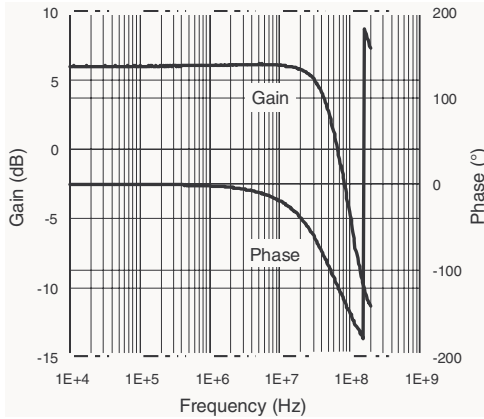

**Figure 33. Overshoot function of output capacitance** (Gain = +2,  $V_{CC} = \pm 5V$ ,  $T_{amb} = 25^\circ C$ )

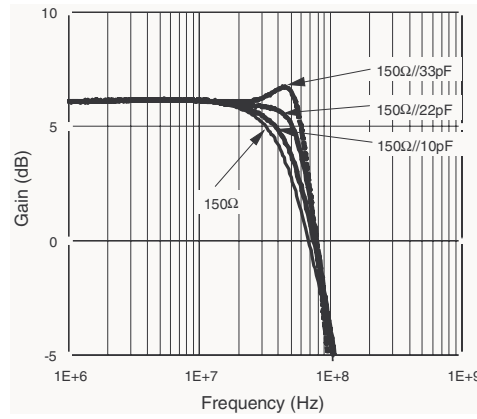

**Figure 34. Closed loop gain and phase vs. frequency** (Gain = -10,  $V_{CC} = \pm 5V$ ,  $R_L = 150\Omega$ ,  $T_{amb} = 25^\circ C$ )

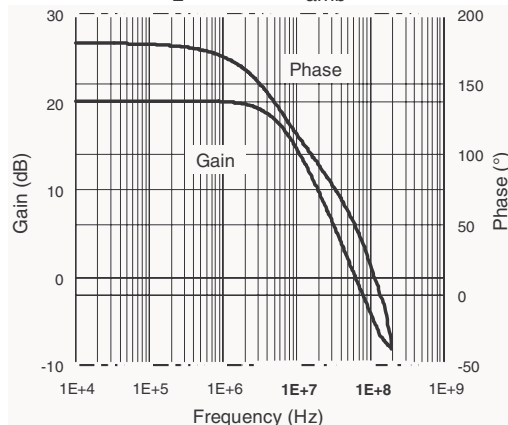

**Figure 35. Closed Loop Gain and Phase vs. Frequency** (Gain = +11,  $V_{CC} = \pm 5V$ ,  $R_L = 150\Omega$ ,  $T_{amb} = 25^\circ C$ )

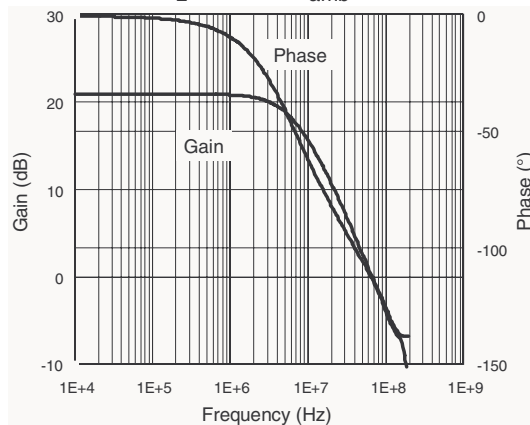

**Figure 36. Large signal measurement - positive slew rate** (Gain = 2,  $V_{CC} = \pm 5V$ ,  $Z_L = 150\Omega//5.6pF$ )

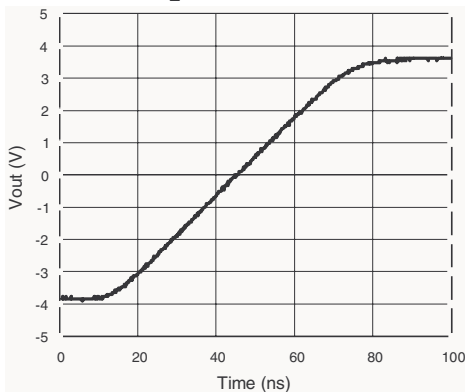

**Figure 37. Large Signal Measurement - Negative Slew Rate** (Gain = 2,  $V_{CC} = \pm 5V$ ,  $Z_L = 150\Omega//5.6pF$ )

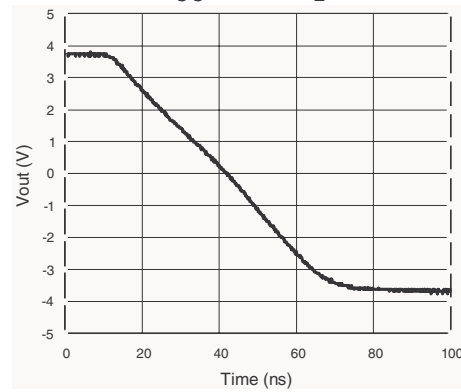

**Figure 38. Small signal measurement - rise time** (Gain = 2,  $V_{CC} = \pm 5V$ ,  $Z_L = 150\Omega$ )

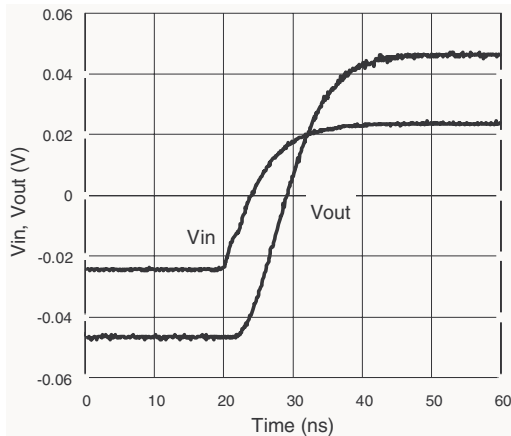

**Figure 39. Small signal measurement - fall time** (Gain = 2,  $V_{CC} = \pm 5V$ ,  $Z_L = 150\Omega$ )

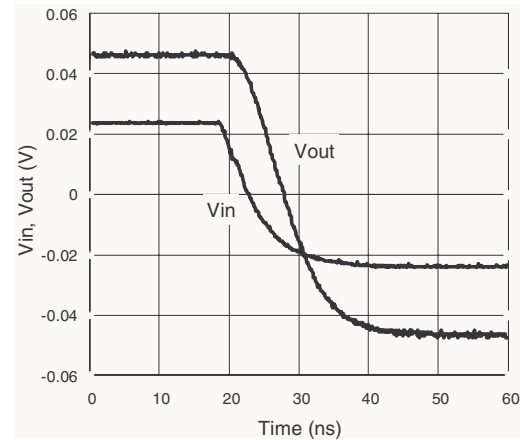

**Figure 40. Channel separation (Xtalk) vs. frequency** (measurement configuration:  $Xtalk = 20\log(V0/V1)$ )

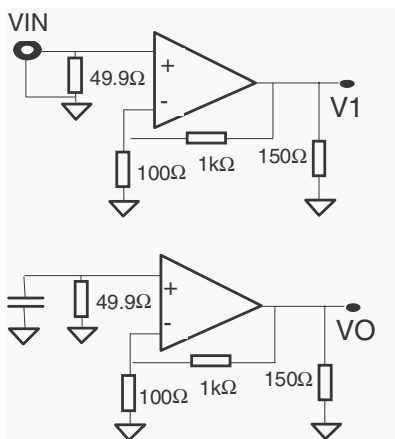

**Figure 41. Channel separation (Xtalk) vs. frequency** (Gain = +11,  $V_{CC} = \pm 5V$ ,  $Z_L = 150\Omega/27pF$ )

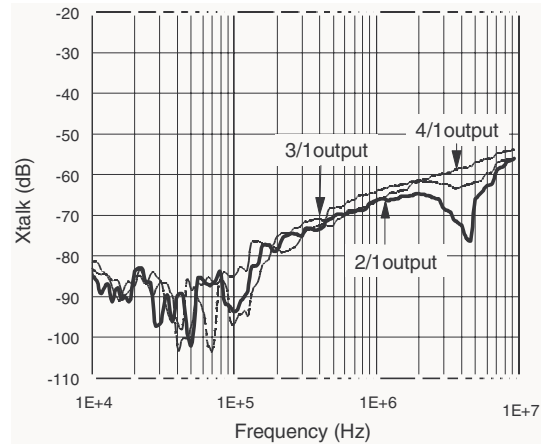

**Figure 42. Equivalent noise voltage** (Gain = 100,  $V_{CC} = \pm 5V$ , no load)

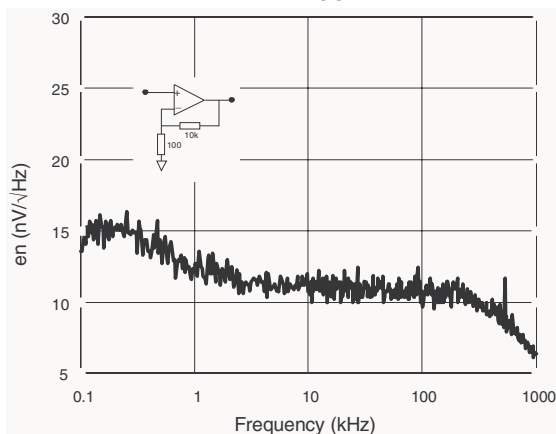

**Figure 43. Maximum output swing** (Gain = 11,  $V_{CC} = \pm 5V$ ,  $R_L = 150\Omega$ )

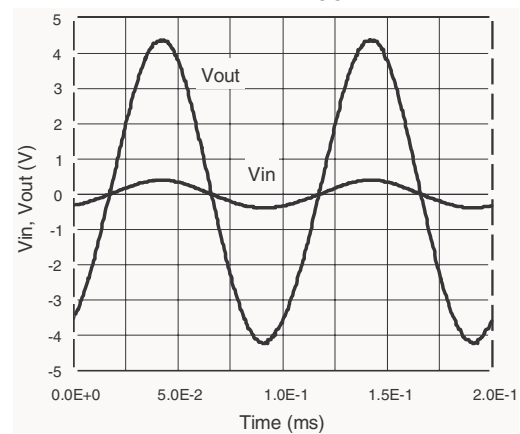

**Figure 44. Standby mode -  $T_{on}$ ,  $T_{off}$**   
 ( $V_{CC} = \pm 5V$ , open loop)

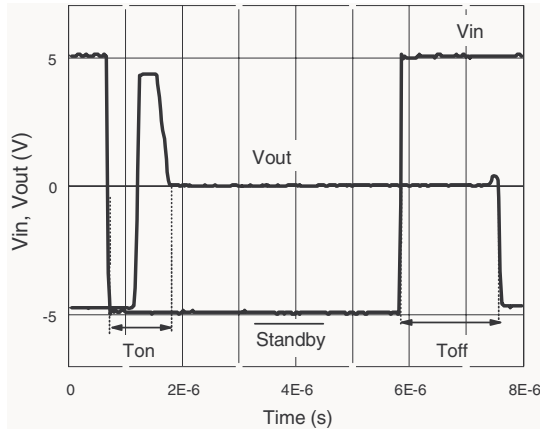

**Figure 45. Group Delay (Gain = 2,  $V_{CC} = \pm 5V$ ,  $Z_L = 150\Omega // 27pF$ ,  $T_{amb} = 25^\circ C$ )**

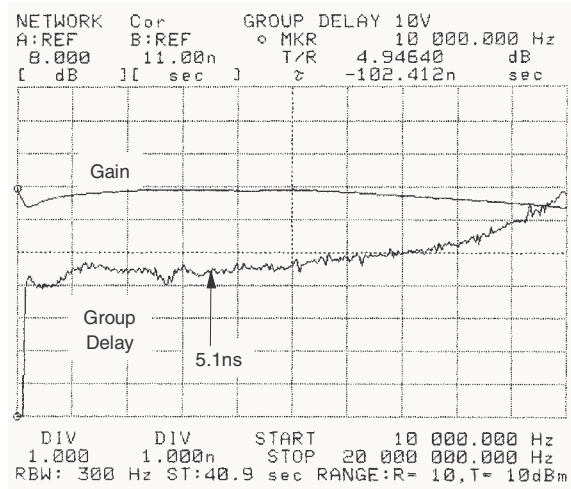

**Figure 46. Third order intermodulation<sup>(1)</sup>**  
 (Gain = 2,  $V_{CC} = \pm 5V$ ,  $Z_L = 150\Omega // 27pF$ ,  $T_{amb} = 25^\circ C$ )

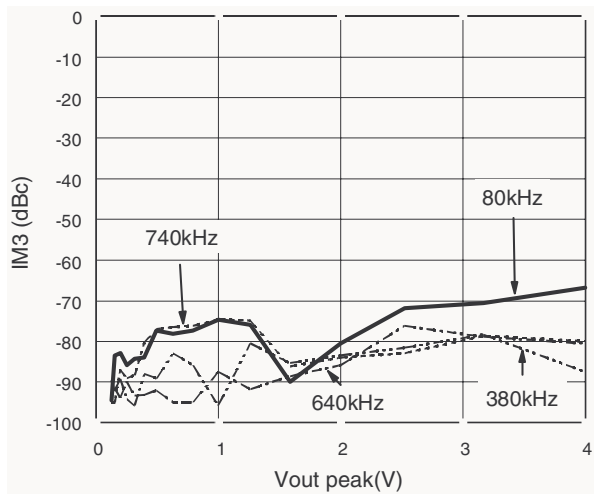

- Note on intermodulation products:  
 The IFR2026 synthesizer generates a two tones signal ( $F_1=180kHz$ ,  $F_2=280kHz$ ); each tone having the same amplitude level.  
 The HP3585 spectrum analyzer measures the intermodulation products function of the output voltage.  
 The generator and the spectrum analyzer are phase locked for precision considerations.

## 5 Testing Conditions

### 5.1 Layout precautions

To use the TSH7X circuits in the best manner at high frequencies, some precautions have to be taken for power supplies:

- First of all, the implementation of a proper ground plane in both sides of the PCB is mandatory for high speed circuit applications to provide low inductance and low resistance common return.
- Power supply bypass capacitors (4.7uF and ceramic 100pF) should be placed as close as possible to the IC pins in order to improve high frequency bypassing and reduce harmonic distortion. The power supply capacitors must be incorporated for both the negative and the positive pins.
- Proper termination of all inputs and outputs must be in accordance with output termination resistors; in this way, the amplifier load will be resistive only, and the stability of the amplifier will be improved.
- All leads must be wide and as short as possible (especially for op-amp inputs and outputs) in order to decrease parasitic capacitance and inductance.
- For lower gain applications, care should be taken to avoid large feedback resistance (>1kΩ) in order to reduce the time constant of parasitic capacitances.
- Choose component sizes as small as possible (SMD).
- Finally, on output, the load capacitance must be negligible to maintain good stability. You can put a serial resistance as close as possible to the output pin to minimize capacitance.

### 5.2 Maximum input level

Figure 47. CCIR330 video line

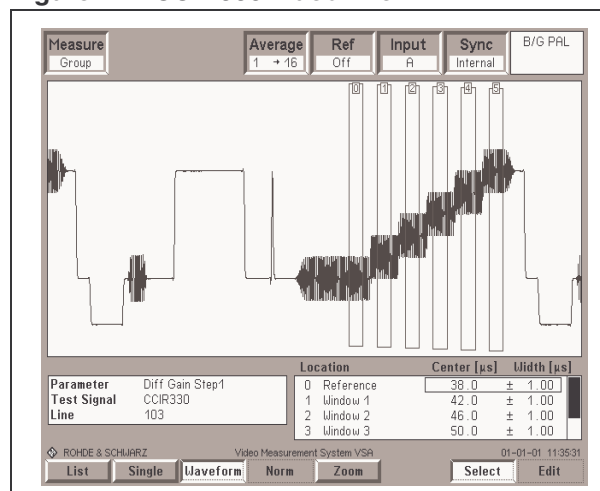

The input level must not exceed the following values:

- negative peak: must be greater than  $-V_{CC}+400\text{mV}$ .
- positive peak value: must be lower than  $+V_{CC}-400\text{mV}$ .

The electrical characteristics show the influence of the load on this parameter.

### 5.3 Video capabilities

To characterize the differential phase and differential gain, a CCIR330 video line is used.

The video line contains 5 (flat) levels of luma on which is superimposed chroma signal. The first level contains no luma. The luma gives various amplitudes which define the saturation of the signal. The chrominance gives various phases which define the color of the signal.

Differential phase (respectively differential gain) distortion is present if a signal chrominance phase (gain) is affected by luminance level. They represent the ability to uniformly process the high frequency information at all luminance levels.

When differential gain is present, color saturation is not correctly reproduced.

The input generator is the Rohde & Schwarz CCVS. The output measurement was done by the Rohde and Schwarz VSA.

Figure 48. Measurement on Rohde and Schwarz VSA

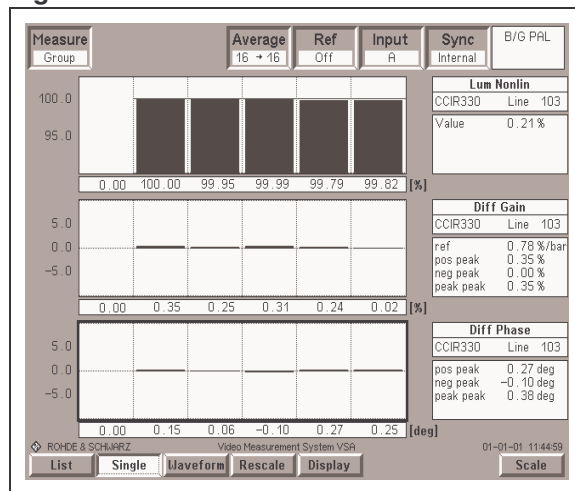

Table 7. Video results

Parameter	Value	Value	Unit
	$V_{CC} = \pm 2.5V$	$V_{CC} = \pm 5V$	
Lum NL	0.1	0.3	%
Lum NL Step 1	100	100	%
Lum NL Step 2	100	99.9	%
Lum NL Step 3	99.9	99.8	%
Lum NL Step 4	99.9	99.9	%
Lum NL Step 5	99.9	99.7	%
Diff Gain pos	0	0	%
Diff Gain neg	-0.7	-0.6	%
Diff Gain pp	0.7	0.6	%

Table 7. Video results

Parameter	Value $V_{CC} = \pm 2.5V$	Value $V_{CC} = \pm 5V$	Unit
Diff Gain Step1	-0.5	-0.3	%
Diff Gain Step2	-0.7	-0.6	%
Diff Gain Step3	-0.3	-0.5	%
Diff Gain Step4	-0.1	-0.3	%
Diff Gain Step5	-0.4	-0.5	%
Diff Phase pos	0	0.1	deg
Diff Phase neg	-0.2	-0.4	deg
Diff Phase pp	0.2	0.5	deg
Diff Phase Step1	-0.2	-0.4	deg
Diff Phase Step2	-0.1	-0.4	deg
Diff Phase Step3	-0.1	-0.3	deg
Diff Phase Step4	0	0.1	deg
Diff Phase Step5	-0.2	-0.1	deg

### 5.4 Precautions when operating on an asymmetrical supply

The TSH7X can be used with either a dual or a single supply. If a single supply is used, the inputs are biased to the mid-supply voltage ( $+V_{CC}/2$ ). This bias network must be carefully designed, in order to reject any noise present on the supply rail.

As the bias current is 15uA, you must carefully choose the resistance R1 so as not to introduce an offset mismatch at the amplifier inputs.

Figure 49. Schematic of asymmetrical (single) supply

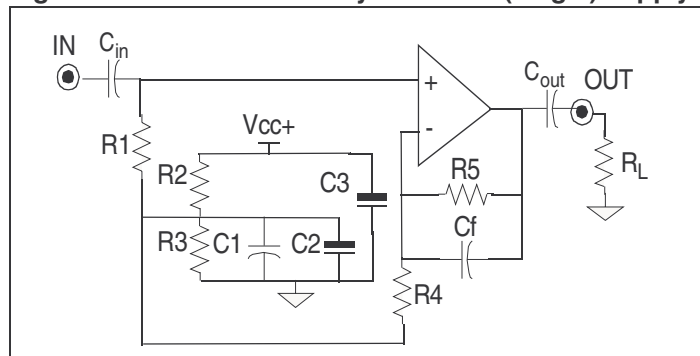

R1 = 10KΩ is a typical and convenient value. C1, C2, C3 are bypass capacitors that filter perturbations on  $V_{CC}$ , as well as for the input and output signals. We choose C1 = 100nF and C2 = C3 = 100uF.

R2, R3 are such that the current through them must be greater than 100 times the bias current. Therefore, we set R2 = R3 = 4.7KΩ.

$C_{in}$ , as  $C_{out}$ , is chosen to filter the DC signal by the low-pass filters ( $R1, C_{in}$  and  $R_{out}, C_{out}$ ). By taking  $R1 = 10K\Omega$ ,  $R_L = 150\Omega$ , and  $C_{in} = 2\mu F$ ,  $C_{out}=220\mu F$  we provide a cut-off frequency below 10Hz.

**Figure 50. Use of the TSH7x in gain = -1 configuration**

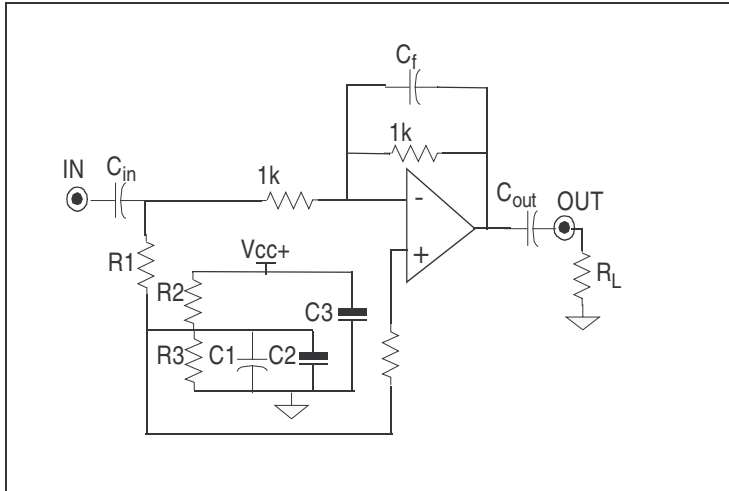

Some precautions must be taken, especially for low-power supply applications.

A feedback capacitance,  $C_f$ , should be added for better stability. *Table 8* summarizes the impact of the capacitance  $C_f$  on the phase margin of the circuit.

**Table 8. Impact capacitance  $C_f$**

Parameter	$C_f$ (pF)	$V_{CC} = \pm 1.5V$	$V_{CC} = \pm 2.5V$	$V_{CC} = \pm 5V$	Unit
Phase Margin	0	28	43	56	deg
f-3dB		40	39.3	38.3	MHz
Phase Margin	5.6	30	43	56	deg
f-3dB		40	39.3	38.3	MHz
Phase Margin	22	37	52	67	deg
f-3dB		37	34	32	MHz
Phase Margin	33	48	65	78	deg
f-3dB		33.7	30.7	27.6	MHz

## 6 Package Mechanical Data

In order to meet environmental requirements, ST offers these devices in ECOPACK® packages. These packages have a Lead-free second level interconnect. The category of second level interconnect is marked on the package and on the inner box label, in compliance with JEDEC Standard JESD97. The maximum ratings related to soldering conditions are also marked on the inner box label. ECOPACK is an ST trademark. ECOPACK specifications are available at: [www.st.com](http://www.st.com).

### 6.1 SO-8 Package

SO-8 MECHANICAL DATA						
DIM.	mm.			inch		
	MIN.	TYP.	MAX.	MIN.	TYP.	MAX.
A	1.35		1.75	0.053		0.069
A1	0.10		0.25	0.04		0.010
A2	1.10		1.65	0.043		0.065
B	0.33		0.51	0.013		0.020
C	0.19		0.25	0.007		0.010
D	4.80		5.00	0.189		0.197
E	3.80		4.00	0.150		0.157
e		1.27			0.050	
H	5.80		6.20	0.228		0.244
h	0.25		0.50	0.010		0.020
L	0.40		1.27	0.016		0.050
k	8° (max.)					
ddd			0.1			0.04

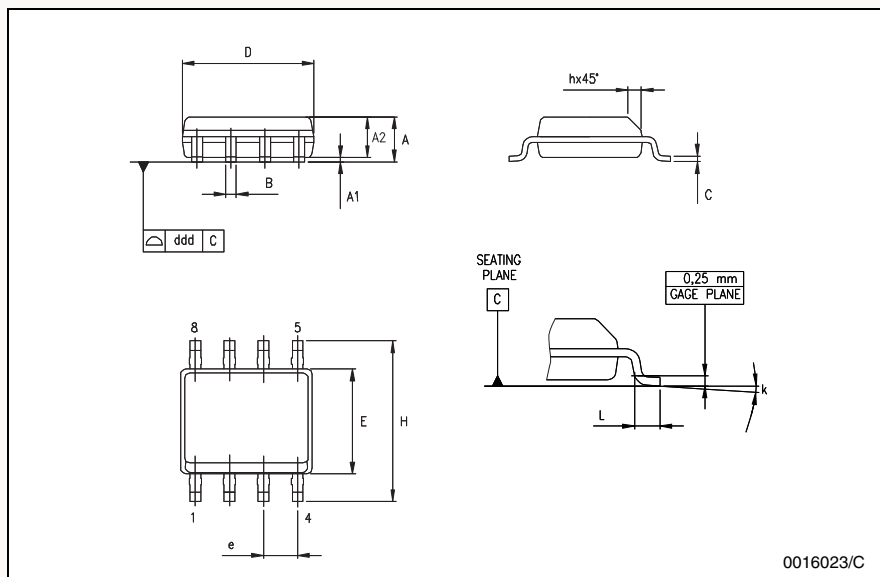

## 6.2 TSSOP8 Package

TSSOP8 MECHANICAL DATA						
DIM.	mm.			inch		
	MIN.	TYP.	MAX.	MIN.	TYP.	MAX.
A			1.2			0.047
A1	0.05		0.15	0.002		0.006
A2	0.80	1.00	1.05	0.031	0.039	0.041
b	0.19		0.30	0.007		0.012
c	0.09		0.20	0.004		0.008
D	2.90	3.00	3.10	0.114	0.118	0.122
E	6.20	6.40	6.60	0.244	0.252	0.260
E1	4.30	4.40	4.50	0.169	0.173	0.177
e		0.65			0.0256	
K	0°		8°	0°		8°
L	0.45	0.60	0.75	0.018	0.024	0.030
L1		1			0.039	

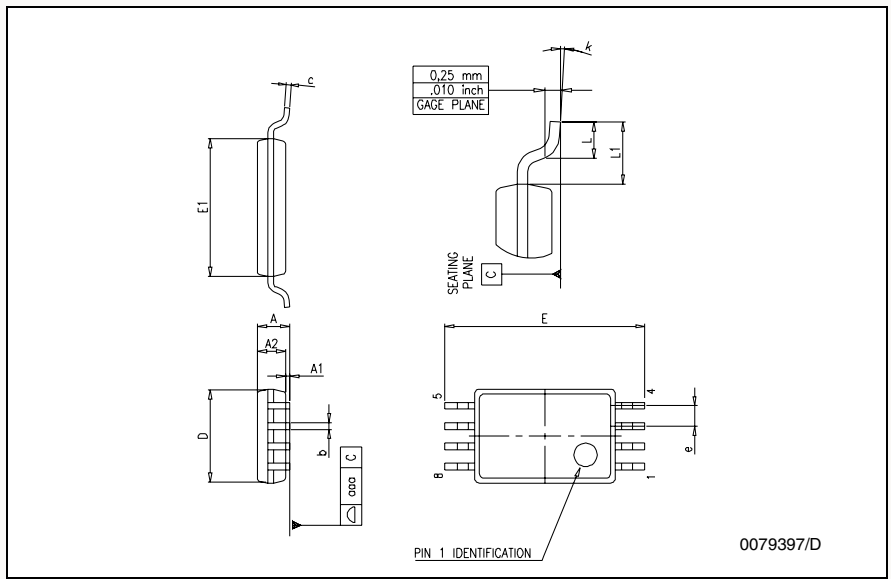

## 6.3 SO-14 Package

SO-14 MECHANICAL DATA						
DIM.	mm.			inch		
	MIN.	TYP.	MAX.	MIN.	TYP.	MAX.
A			1.75			0.068
a1	0.1		0.2	0.003		0.007
a2			1.65			0.064
b	0.35		0.46	0.013		0.018
b1	0.19		0.25	0.007		0.010
C		0.5			0.019	
c1	45° (typ.)					
D	8.55		8.75	0.336		0.344
E	5.8		6.2	0.228		0.244
e		1.27			0.050	
e3		7.62			0.300	
F	3.8		4.0	0.149		0.157
G	4.6		5.3	0.181		0.208
L	0.5		1.27	0.019		0.050
M			0.68			0.026
S	8° (max.)					

PO13G

### 6.4 TSSOP14 Package

TSSOP14 MECHANICAL DATA						
DIM.	mm.			inch		
	MIN.	TYP.	MAX.	MIN.	TYP.	MAX.
A			1.2			0.047
A1	0.05		0.15	0.002	0.004	0.006
A2	0.8	1	1.05	0.031	0.039	0.041
b	0.19		0.30	0.007		0.012
c	0.09		0.20	0.004		0.0089
D	4.9	5	5.1	0.193	0.197	0.201
E	6.2	6.4	6.6	0.244	0.252	0.260
E1	4.3	4.4	4.48	0.169	0.173	0.176
e		0.65 BSC			0.0256 BSC	
K	0°		8°	0°		8°
L	0.45	0.60	0.75	0.018	0.024	0.030

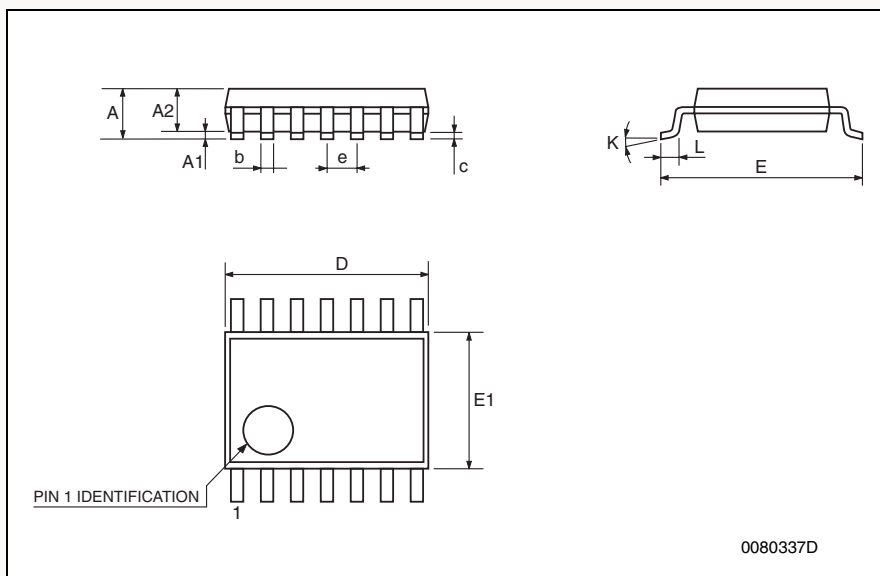

### 6.5 SO-16 Package

**SO-16 MECHANICAL DATA**

DIM.	mm.			inch		
	MIN.	TYP.	MAX.	MIN.	TYP.	MAX.
A			1.75			0.068
a1	0.1		0.2	0.004		0.008
a2			1.65			0.064
b	0.35		0.46	0.013		0.018
b1	0.19		0.25	0.007		0.010
C		0.5			0.019	
c1	45° (typ.)					
D	9.8		10	0.385		0.393
E	5.8		6.2	0.228		0.244
e		1.27			0.050	
e3		8.89			0.350	
F	3.8		4.0	0.149		0.157
G	4.6		5.3	0.181		0.208
L	0.5		1.27	0.019		0.050
M			0.62			0.024
S	8 (max.)					

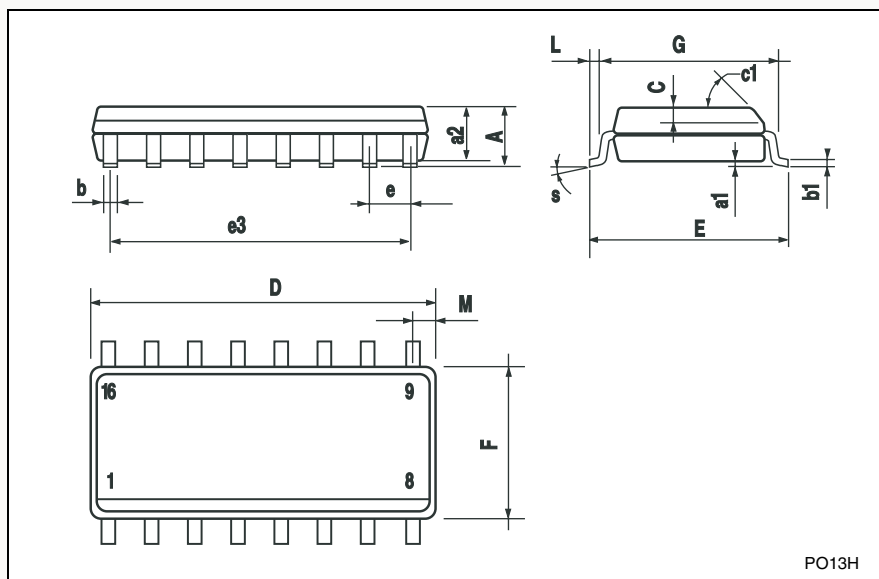

PO13H

## 6.6 TSSOP16 Package

**TSSOP16 MECHANICAL DATA**

DIM.	mm.			inch		
	MIN.	TYP.	MAX.	MIN.	TYP.	MAX.
A			1.2			0.047
A1	0.05		0.15	0.002	0.004	0.006
A2	0.8	1	1.05	0.031	0.039	0.041
b	0.19		0.30	0.007		0.012
c	0.09		0.20	0.004		0.0079
D	4.9	5	5.1	0.193	0.197	0.201
E	6.2	6.4	6.6	0.244	0.252	0.260
E1	4.3	4.4	4.48	0.169	0.173	0.176
e		0.65 BSC			0.0256 BSC	
K	0°		8°	0°		8°
L	0.45	0.60	0.75	0.018	0.024	0.030

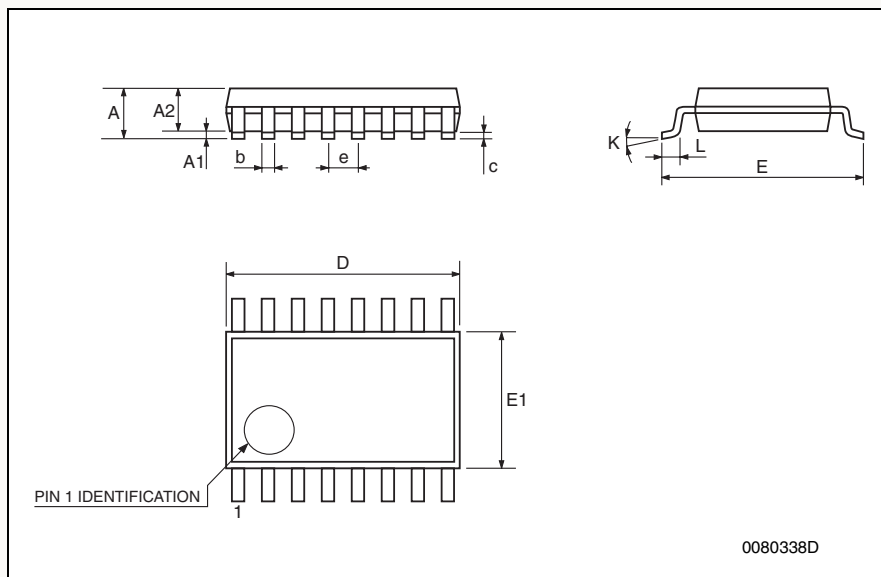

## 6.7 SOT23-5 Package

SOT23-5L MECHANICAL DATA

DIM.	mm.			mils		
	MIN.	TYP.	MAX.	MIN.	TYP.	MAX.
A	0.90		1.45	35.4		57.1
A1	0.00		0.15	0.0		5.9
A2	0.90		1.30	35.4		51.2
b	0.35		0.50	13.7		19.7
C	0.09		0.20	3.5		7.8
D	2.80		3.00	110.2		118.1
E	2.60		3.00	102.3		118.1
E1	1.50		1.75	59.0		68.8
e		0.95			37.4	
e1		1.9			74.8	
L	0.35		0.55	13.7		21.6

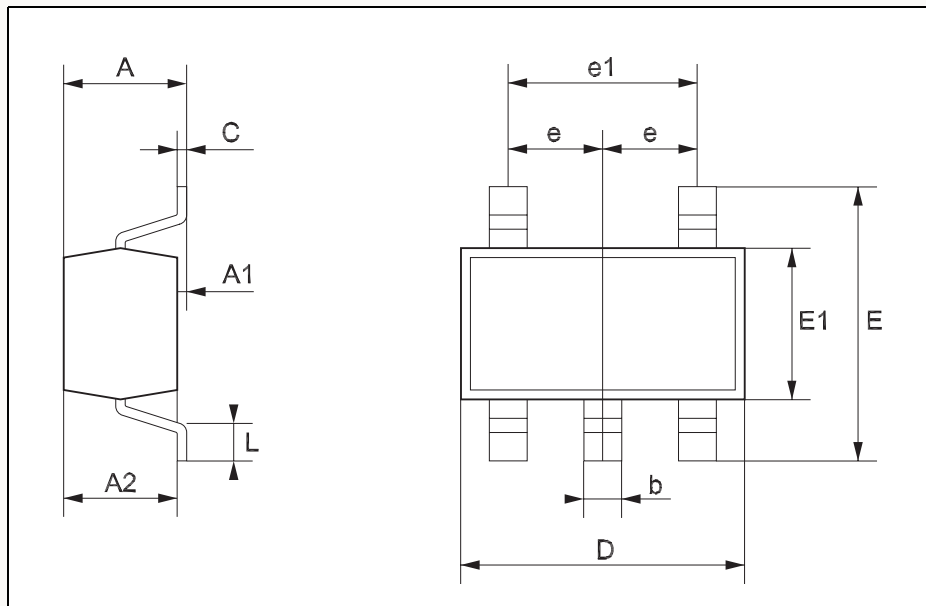

## 7 Revision History

**Table 9. Document revision history**

Date	Revision	Changes
Nov. 2000	1	First Release.
Aug. 2002	2	Limit min. of $I_{\text{sink}}$ from 24mA to 20mA (only on 3V power supply). Reason: yield improvement.
May 2006	3	Improvement of VOL max. at 3V and 5V power supply on 150-ohm load connected to GND (pages 6 and 8). Reason: TSH7x can drive video signals from DACs to lines in single supply (3V or 5V) without any DC level change of the video signals. Grammatical and typographical changes throughout. Package mechanical data updated.

**Please Read Carefully:**

Information in this document is provided solely in connection with ST products. STMicroelectronics NV and its subsidiaries ("ST") reserve the right to make changes, corrections, modifications or improvements, to this document, and the products and services described herein at any time, without notice.

All ST products are sold pursuant to ST's terms and conditions of sale.

Purchasers are solely responsible for the choice, selection and use of the ST products and services described herein, and ST assumes no liability whatsoever relating to the choice, selection or use of the ST products and services described herein.

No license, express or implied, by estoppel or otherwise, to any intellectual property rights is granted under this document. If any part of this document refers to any third party products or services it shall not be deemed a license grant by ST for the use of such third party products or services, or any intellectual property contained therein or considered as a warranty covering the use in any manner whatsoever of such third party products or services or any intellectual property contained therein.

**UNLESS OTHERWISE SET FORTH IN ST'S TERMS AND CONDITIONS OF SALE ST DISCLAIMS ANY EXPRESS OR IMPLIED WARRANTY WITH RESPECT TO THE USE AND/OR SALE OF ST PRODUCTS INCLUDING WITHOUT LIMITATION IMPLIED WARRANTIES OF MERCHANTABILITY, FITNESS FOR A PARTICULAR PURPOSE (AND THEIR EQUIVALENTS UNDER THE LAWS OF ANY JURISDICTION), OR INFRINGEMENT OF ANY PATENT, COPYRIGHT OR OTHER INTELLECTUAL PROPERTY RIGHT.**

**UNLESS EXPRESSLY APPROVED IN WRITING BY AN AUTHORIZED REPRESENTATIVE OF ST, ST PRODUCTS ARE NOT DESIGNED, AUTHORIZED OR WARRANTED FOR USE IN MILITARY, AIR CRAFT, SPACE, LIFE SAVING, OR LIFE SUSTAINING APPLICATIONS, NOR IN PRODUCTS OR SYSTEMS, WHERE FAILURE OR MALFUNCTION MAY RESULT IN PERSONAL INJURY, DEATH, OR SEVERE PROPERTY OR ENVIRONMENTAL DAMAGE.**

Resale of ST products with provisions different from the statements and/or technical features set forth in this document shall immediately void any warranty granted by ST for the ST product or service described herein and shall not create or extend in any manner whatsoever, any liability of ST.

ST and the ST logo are trademarks or registered trademarks of ST in various countries.

Information in this document supersedes and replaces all information previously supplied.

The ST logo is a registered trademark of STMicroelectronics. All other names are the property of their respective owners.

© 2006 STMicroelectronics - All rights reserved

STMicroelectronics group of companies

Australia - Belgium - Brazil - Canada - China - Czech Republic - Finland - France - Germany - Hong Kong - India - Israel - Italy - Japan - Malaysia - Malta - Morocco - Singapore - Spain - Sweden - Switzerland - United Kingdom - United States of America

[www.st.com](http://www.st.com)