



DUAL WIDE BAND OPERATIONAL AMPLIFIER WITH HIGH OUTPUT CURRENT

- LOW NOISE : $3\text{nV}/\sqrt{\text{Hz}}$, $1.2\text{pA}/\sqrt{\text{Hz}}$
- HIGH OUTPUT CURRENT : **200mA**
- VERY LOW HARMONIC AND INTERMODULATION DISTORTION
- HIGH SLEW RATE : **40V/μs**
- SPECIFIED FOR **25Ω** LOAD

DESCRIPTION

The TS613 is a dual operational amplifier featuring a high output current (200mA min.), large gain-bandwidth product (130MHz) and capable of driving a 25Ω load with a 160mA output current at ±6V power supply.

This device is particularly intended for applications where multiple carriers must be amplified simultaneously with very low intermodulation products.

The TS613 is housed in a SO8 plastic package and a SO8 Exposed-Pad plastic package.

APPLICATION

- UPSTREAM line driver for Asymmetric Digital Subscriber Line (ADSL) (NT).

ORDER CODE

Part Number	Temperature Range	Package	
		D	DW
TS613ID	-40, +85°C	•	
TS613IDW	-40, +85°C		•

D = Small Outline Package (SO) - also available in Tape & Reel (DT)
DW = Small Outline Package in Exposed-Pad (SO) - also available in Tape & Reel (DWT)

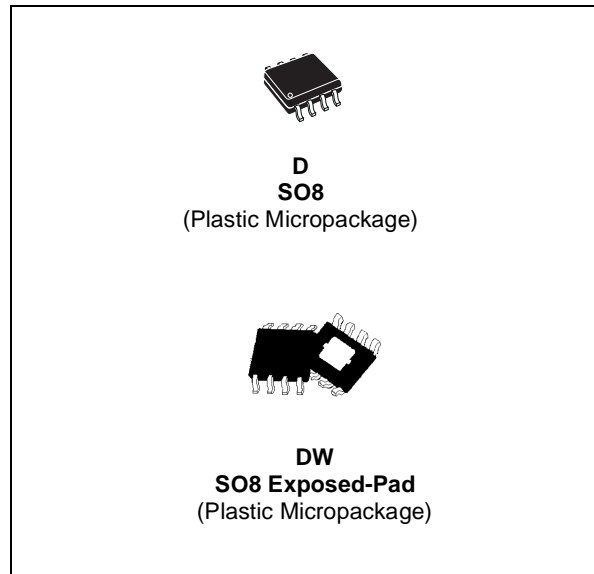

PIN CONNECTIONS (top view)

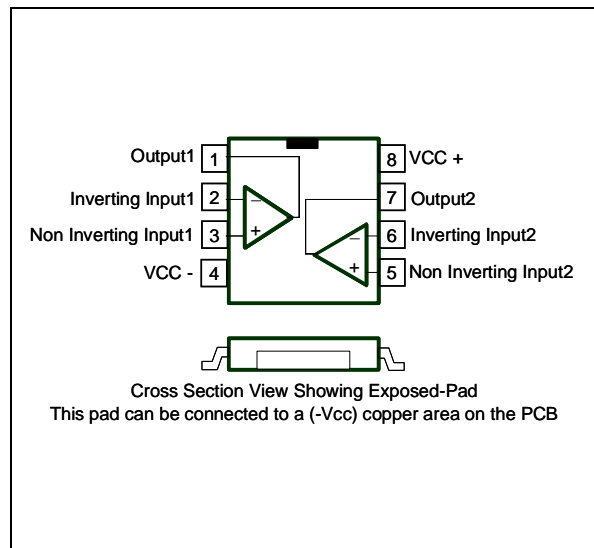

ABSOLUTE MAXIMUM RATINGS

Symbol	Parameter	Value	Unit
V_{CC}	Supply voltage ¹⁾	± 7	V
V_{id}	Differential Input Voltage ²⁾	± 2	V
V_{in}	Input Voltage Range ³⁾	± 6	V
T_{oper}	Operating Free Air Temperature Range	-40 to + 85	°C
T_{std}	Storage Temperature	-65 to +150	°C
T_j	Maximum Junction Temperature	150	°C
	Output Short Circuit Duration	4)	
SO8			
R_{thjc}	Thermal Resistance Junction to Case	28	°C/W
R_{thja}	Thermal Resistance Junction to Ambient Area	175	°C/W
$P_{max.}$	Maximum Power Dissipation (@25°C)	715	mW
SO8 Exposed-Pad			
R_{thjc}	Thermal Resistance Junction to Case	16	°C/W
R_{thja}	Thermal Resistance Junction to Ambient Area	60	°C/W
$P_{max.}$	Maximum Power Dissipation (@25°C)	2000	mW

1. All voltages values, except differential voltage are with respect to network terminal.
2. Differential voltages are non-inverting input terminal with respect to the inverting input terminal.
3. The magnitude of input and output voltages must never exceed $V_{CC} + 0.3V$.
4. An output current limitation protects the circuit from transient currents. Short-circuits can cause excessive heating. Destructive dissipation can result from short circuit on amplifiers.

OPERATING CONDITIONS

Symbol	Parameter	Value	Unit
V_{CC}	Supply Voltage	± 2.5 to ± 6	V
V_{icm}	Common Mode Input Voltage	$(V_{CC}) + 2$ to $(V_{CC}^+) - 1$	V

ELECTRICAL CHARACTERISTICS $V_{CC} = \pm 6V$, $T_{amb} = 25^{\circ}C$ (unless otherwise specified).

Symbol	Parameter	Test Condition	Min.	Typ.	Max	Unit
DC PERFORMANCE						
V_{io}	Input Offset Voltage	T_{amb}	-6	-1	6	mV
		$T_{min.} < T_{amb} < T_{max.}$			10	
ΔV_{io}	Differential Input Offset Voltage	$T_{amb} = 25^{\circ}C$			6	mV
I_{io}	Input Offset Current	T_{amb}		0.2	3	μA
		$T_{min.} < T_{amb} < T_{max.}$			5	
I_{ib}	Input Bias Current	T_{amb}		5	15	μA
		$T_{min.} < T_{amb} < T_{max.}$			30	
CMR	Common Mode Rejection Ratio	$V_{ic} = \pm 2V$, T_{amb}	90	108		dB
		$T_{min.} < T_{amb} < T_{max.}$	70			
SVR	Supply Voltage Rejection Ratio	$V_{ic} = \pm 6V$ to $\pm 4V$, T_{amb}	70	88		dB
		$T_{min.} < T_{amb} < T_{max.}$	50			
I_{CC}	Total Supply Current per Operator	No load, $V_{out} = 0$		11		mA
DYNAMIC PERFORMANCE and OUTPUT CHARACTERISTICS						
V_{OH}	High Level Output Voltage	$I_{out} = 160mA$, R_L to GND	4	4.5		V
V_{OL}	Low Level Output Voltage	$I_{out} = 160mA$, R_L to GND		-4.5	-4	V
A_{VD}	Large Signal Voltage Gain	$V_{out} = 7V$ peak $R_L = 25\Omega$, T_{amb}	6500	11000		V/V
		$T_{min.} < T_{amb} < T_{max.}$	5000			
GBP	Gain Bandwidth Product	$A_{VCL} = +11$, $f = 20MHz$ $R_L = 100\Omega$	80	130		MHz
SR	Slew Rate	$A_{VCL} = +7$, $R_L = 50\Omega$	23	40		V/ μs
I_{sink} I_{source}	Output Short Circuit Current	$V_{id} = \pm 1V$, T_{amb}	± 200	± 320		mA
		$T_{min.} < T_{amb} < T_{max.}$	± 180			
ΦM_{14}	Phase Margin at $A_{VCL} = 14dB$	$R_L = 25\Omega//15pF$		60		$^{\circ}$
ΦM_6	Phase Margin at $A_{VCL} = 6dB$	$R_L = 25\Omega//15pF$		40		$^{\circ}$
NOISE AND DISTORTION						
e_n	Equivalent Input Noise Voltage	$f = 100kHz$		3		nV/ \sqrt{Hz}
i_n	Equivalent Input Noise Current	$f = 100kHz$		1.2		pA/ \sqrt{Hz}
THD	Total Harmonic Distortion	$V_{out} = 4V_{pp}$, $f = 100kHz$ $A_{VCL} = -10$ $R_L = 25\Omega//15pF$		-69		dB
HD2 ₋₁₀	2nd Harmonic Distortion	$V_{out} = 4V_{pp}$, $f = 100kHz$ $A_{VCL} = -10$ Load = $25\Omega//15pF$		-70		dBc
HD2 ₊₂	2nd Harmonic Distortion	$V_{out} = 4V_{pp}$, $f = 100kHz$ $A_{VCL} = +2$ Load = $25\Omega//15pF$		-74		dBc
HD3 ₋₁₀	3rd Harmonic Distortion	$V_{out} = 4V_{pp}$, $f = 100kHz$ $A_{VCL} = -10$ Load = $25\Omega//15pF$		-80		dBc
HD3 ₊₂	3rd Harmonic Distortion	$V_{out} = 4V_{pp}$, $f = 100kHz$ $A_{VCL} = +2$ Load = $25\Omega//15pF$		-79		dBc
IM2 ₋₁₀	2nd Order Intermodulation Product	$F_1 = 80kHz$, $F_2 = 70kHz$ $V_{out} = 8V_{pp}$, $A_{VCL} = -10$ Load = $25\Omega//15pF$		-77		dBc
IM3 ₋₁₀	3rd Order Intermodulation Product	$F_1 = 80kHz$, $F_2 = 70kHz$ $V_{out} = 8V_{pp}$, $A_{VCL} = -10$ Load = $25\Omega//15pF$		-77		dBc

THERMAL INFORMATION

The TS613 is housed in an Exposed-Pad plastic package. As described on the figures below, this package uses a leadframe upon which the dice is mounted. This leadframe is exposed as a thermal pad on the underside of the package. The thermal contact is direct with the dice. This thermal path provide an excellent thermal performance.

The thermal pad is electrically isolated from all pins in the package. It can also be soldered to a copper area of the PCB underneath the package. Through these thermal paths within this copper area, heat can be conducted away from the package. In this case, the copper area must be connected to (-Vcc)

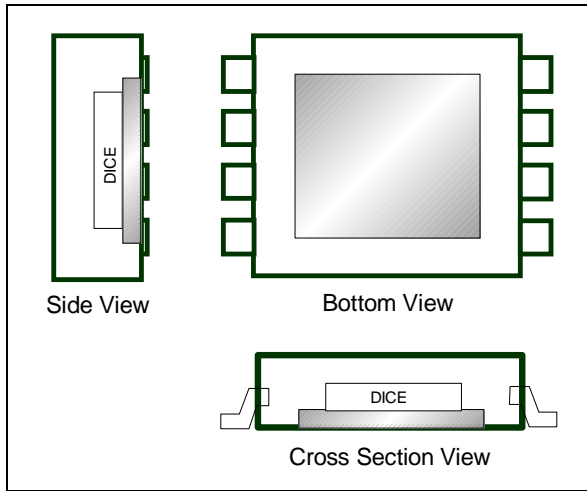

INTERMODULATION DISTORTION

The curves shown below are the measurements results of a single operator wired as an adder with a gain of 15dB.

The operational amplifier is supplied by a symmetric $\pm 6V$ and is loaded with 25Ω .

Two synthesizers (Rhode & Schwartz SME) generate two frequencies (tones) (70 & 80kHz ; 180 & 280kHz).

An HP3585 spectrum analyzer measures the spurious level at different frequencies.

The curves are traced for different output levels (the value in the X ax is the value of each tone).

The output levels of the two tones are the same. The generators and spectrum analyzer are phase locked to enhance measurement precision.

3rd ORDER INTERMODULATION

Gain=15dB, $V_{cc}=\pm 6V$, $R_L=25\Omega$, 2 tones 70kHz/80kHz

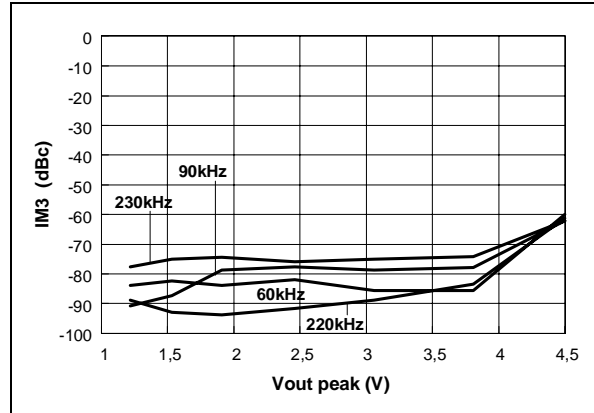

2nd ORDER INTERMODULATION

Gain=15dB, $V_{cc}=\pm 6V$, $R_L=25\Omega$, 2 tones 180kHz/280kHz, Spurious measurement @100kHz

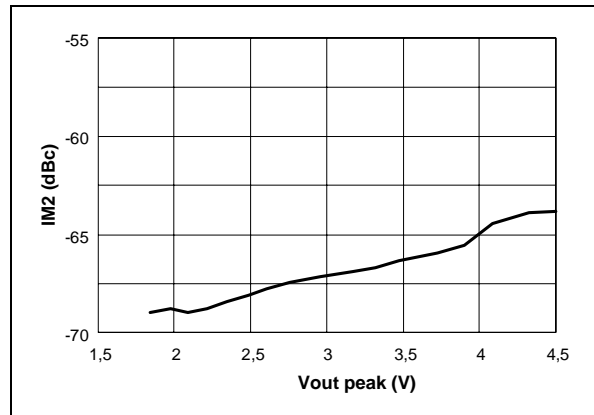

3rd ORDER INTERMODULATION

Gain=15dB, $V_{cc}=\pm 6V$, $R_L=25\Omega$, 2 tones 180kHz/280kHz

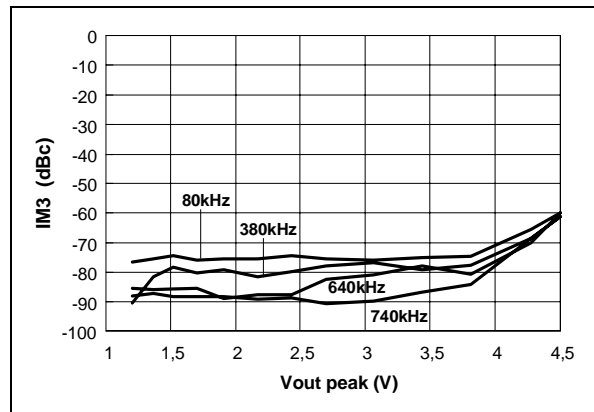

Closed Loop Gain and Phase vs. Frequency
Gain=+2, $V_{cc}=\pm 6V$, $R_L=25\Omega$

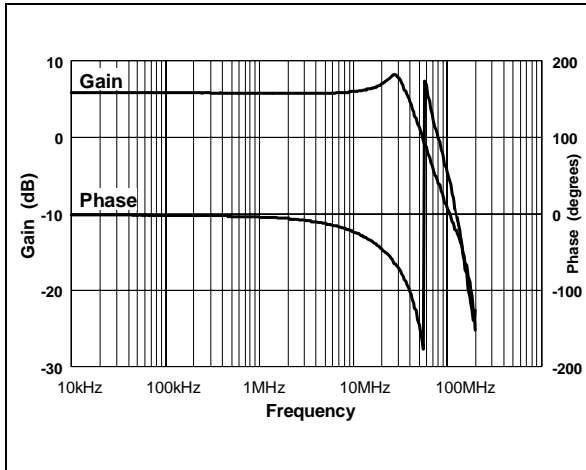

Closed Loop Gain and Phase vs. Frequency
Gain=+6, $V_{cc}=\pm 6V$, $R_L=25\Omega$

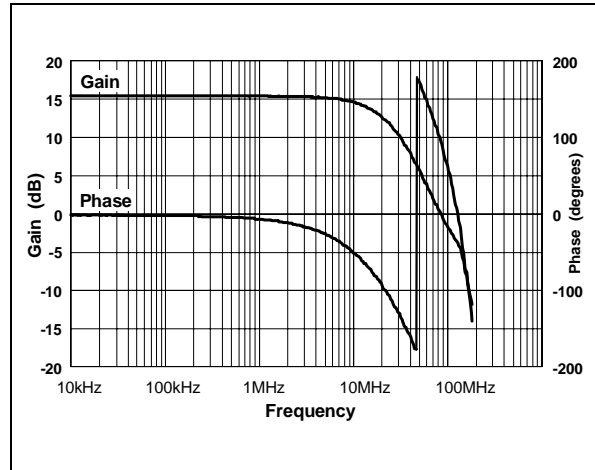

Closed Loop Gain and Phase vs. Frequency
Gain=+11, $V_{cc}=\pm 6V$, $R_L=25\Omega$

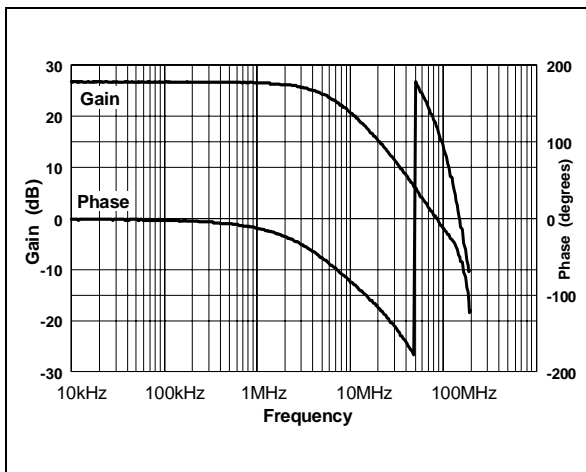

Equivalent Input Voltage Noise
Gain=+100, $V_{cc}=\pm 6V$, no load

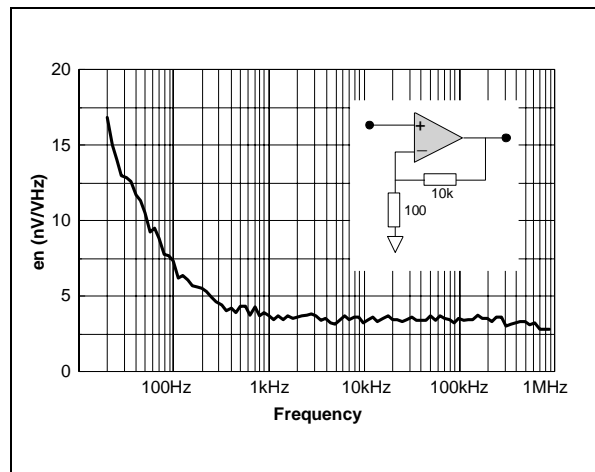

Maximum Output Swing
 $V_{cc}=\pm 6V$, $R_L=25\Omega$

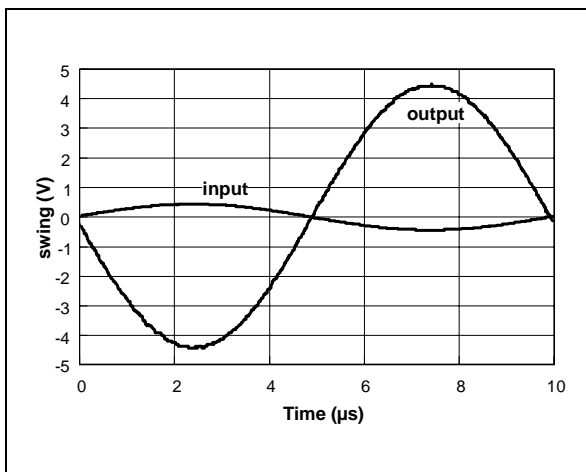

Channel Separation (Xtalk) vs. Frequency
 $X_{Talk}=20\log(V_2/V_1)$, $V_{cc}=\pm 6V$, $R_L=25\Omega$

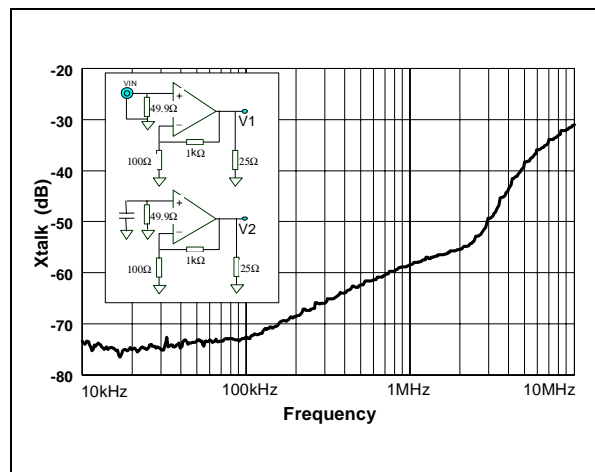

TYPICAL APPLICATION : TS613 AS DRIVER FOR ADSL LINE INTERFACES

A SINGLE SUPPLY IMPLEMENTATION WITH PASSIVE OR ACTIVE IMPEDANCE MATCHING

by C. PRUGNE

ADSL CONCEPT

Asymmetric Digital Subscriber Line (ADSL), is a new modem technology, which converts the existing twisted-pair telephone lines into access paths for multimedia and high speed data communications.

ADSL transmits more than 8 Mbps to a subscriber, and can reach 1Mbps from the subscriber to the central office. ADSL can literally transform the actual public information network by bringing movies, television, video catalogs, remote CD-ROMs, LANs, and the Internet into homes.

An ADSL modem is connected to a twisted-pair telephone line, creating three information channels: a high speed downstream channel (up to 1.1MHz) depending on the implementation of the ADSL architecture, a medium speed upstream channel (up to 130kHz) and a POTS (Plain Old Telephone Service), split off from the modem by filters.

THE LINE INTERFACE - ADSL Remote Terminal (RT):

The Figure1 shows a typical analog line interface used for ADSL. The upstream and downstream signals are separated from the telephone line by using an hybrid circuit and a line transformer. On this note, the accent will be made on the emission path.

Figure 1 : Typical ADSL Line Interface

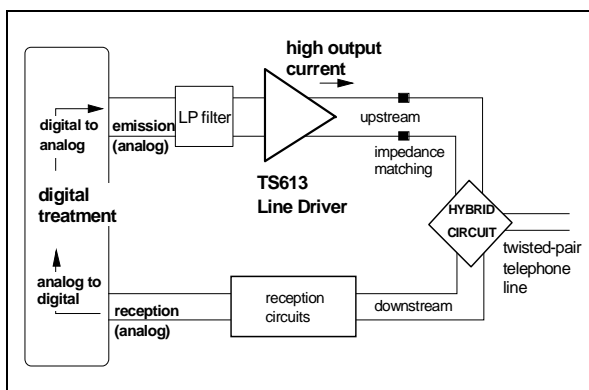

The TS613 is used as a dual line driver for the upstream signal.

For the remote terminal it is required to create an ADSL modem easy to plug in a PC. In such an application, the driver should be implemented with a +12 volts single power supply. This +12V supply is available on PCI connector of purchase.

The figure 2 shows a single +12V supply circuit that uses the TS613 as a remote terminal transmitter in differential mode.

Figure 2 : TS613 as a differential line driver with a +12V single supply

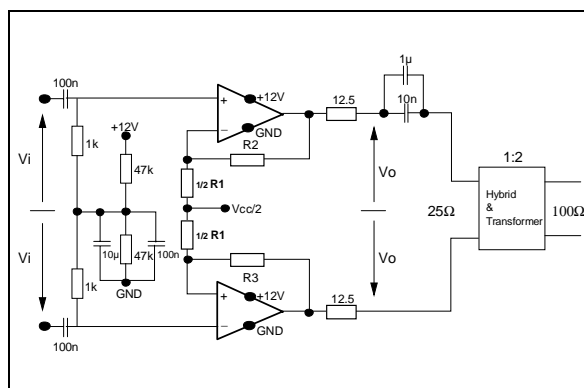

The driver is biased with a mid supply (nominally +6V), in order to maintain the DC component of the signal at +6V. This allows the maximum dynamic range between 0 and +12 V. Several options are possible to provide this bias supply (such as a virtual ground using an operational amplifier), such as a two-resistance divider which is the cheapest solution. A high resistance value is required to limit the current consumption. On the other hand, the current must be high enough to bias the inverting input of the TS613. If we consider this bias current (5µA) as the 1% of the current through the resistance divider (500µA) to keep a stable mid supply, two 47kΩ resistances can be used.

The input provides two high pass filters with a break frequency of about 1.6kHz which is necessary to remove the DC component of the input signal. To avoid DC current flowing in the primary of the transformer, an output capacitor is used. The

1µF capacitance provides a path for low frequencies, the 10nF capacitance provides a path for high end of the spectrum.

In differential mode the TS613 is able to deliver a typical amplitude signal of 18V peak to peak.

The dynamic line impedance is 100Ω. The typical value of the amplitude signal required on the line is up to 12.4V peak to peak. By using a 1:2 transformer ratio the reflected impedance back to the primary will be a quarter (25Ω) and therefore the amplitude of the signal required with this impedance will be the half (6.2 V peak to peak). Assuming the 25Ω series resistance (12.5Ω for both outputs) necessary for impedance matching, the output signal amplitude required is 12.4 V peak to peak. This value is acceptable for the TS613. In this case the load impedance is 25Ω for each driver.

For the ADSL upstream path, a lowpass filter is absolutely necessary to cutoff the higher frequencies from the DAC analog output. In this simple non-inverting amplification configuration, it will be easy to implement a Sallen-Key lowpass filter by using the TS613. For ADSL over POTS, a maximum frequency of 135kHz is reached. For ADSL over ISDN, the maximum frequency will be 276kHz.

INCREASING THE LINE LEVEL BY USING AN ACTIVE IMPEDANCE MATCHING

With passive matching, the output signal amplitude of the driver must be twice the amplitude on the load. To go beyond this limitation an active matching impedance can be used. With this technique it is possible to keep good impedance matching with an amplitude on the load higher than the half of the output driver amplitude. This concept is shown in figure3 for a differential line.

Figure 3 : TS613 as a differential line driver with an active impedance matching

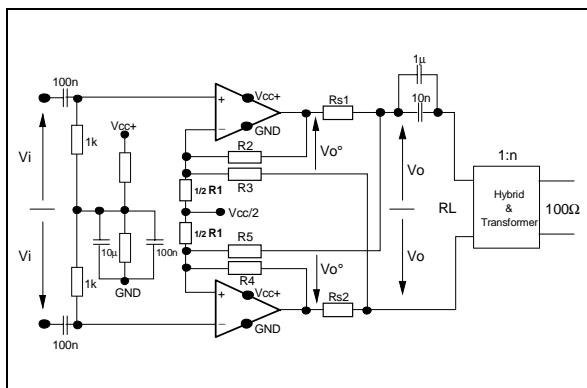

Component calculation:

Let us consider the equivalent circuit for a single ended configuration, figure4.

Figure 4 : Single ended equivalent circuit

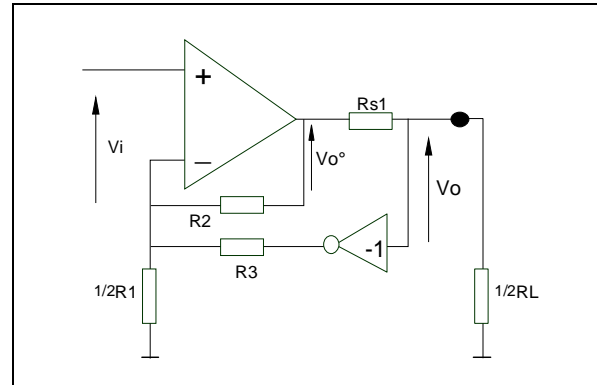

Let us consider the unloaded system. Assuming the currents through R1, R2 and R3 as respectively:

$$\frac{2Vi}{R1}, \frac{(Vi - Vo^\circ)}{R2} \text{ and } \frac{(Vi + Vo)}{R3}$$

As Vo° equals Vo without load, the gain in this case becomes :

$$G = \frac{Vo(noload)}{Vi} = \frac{1 + \frac{2R2}{R1} + \frac{R2}{R3}}{1 - \frac{R2}{R3}}$$

The gain, for the loaded system will be (1):

$$GL = \frac{Vo(withload)}{Vi} = \frac{1}{2} \frac{1 + \frac{2R2}{R1} + \frac{R2}{R3}}{1 - \frac{R2}{R3}} \quad (1)$$

As shown in figure5, this system is an ideal generator with a synthesized impedance as the internal impedance of the system. From this, the output voltage becomes:

$$Vo = (ViG) - (RoIout) \quad (2)$$

with Ro the synthesized impedance and Iout the output current. On the other hand Vo can be expressed as:

$$Vo = \frac{Vi \left(1 + \frac{2R2}{R1} + \frac{R2}{R3} \right)}{1 - \frac{R2}{R3}} - \frac{Rs1 Iout}{1 - \frac{R2}{R3}} \quad (3)$$

By identification of both equations (2) and (3), the synthesized impedance is, with $R_{s1}=R_{s2}=R_s$:

$$R_o = \frac{R_s}{1 - \frac{R_2}{R_3}} \quad (4)$$

Figure 5 : Equivalent schematic. R_o is the synthesized impedance

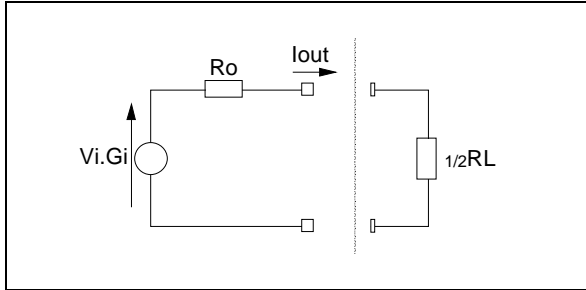

Unlike the level V_o° required for a passive impedance, V_o° will be smaller than $2V_o$ in our case. Let us write $V_o^\circ = kV_o$ with k the matching factor varying between 1 and 2. Assuming that the current through R_3 is negligible, it comes the following resistance divider:

$$R_o = \frac{kV_o R_L}{R_L + 2R_{s1}}$$

After choosing the k factor, R_s will equal to $1/2R_L(k-1)$.

A good impedance matching assumes:

$$R_o = \frac{1}{2}R_L \quad (5)$$

From (4) and (5) it becomes:

$$\frac{R_2}{R_3} = 1 - \frac{2R_s}{R_L} \quad (6)$$

By fixing an arbitrary value for R_2 , (6) gives:

$$R_3 = \frac{R_2}{1 - \frac{2R_s}{R_L}}$$

Finally, the values of R_2 and R_3 allow us to extract R_1 from (1), and it comes:

$$R_1 = \frac{2R_2}{2\left(1 - \frac{R_2}{R_3}\right)GL - 1 - \frac{R_2}{R_3}} \quad (7)$$

with GL the required gain.

GL (gain for the loaded system)	GL is fixed for the application requirements $GL = V_o/V_i = 0.5(1 + 2R_2/R_1 + R_2/R_3)/(1 - R_2/R_3)$
R1	$2R_2/[2(1 - R_2/R_3)GL - 1 - R_2/R_3]$
R2 (=R4)	Arbitrary fixed
R3 (=R5)	$R_2/(1 - R_s/0.5R_L)$
R_s	$0.5R_L(k-1)$

CAPABILITIES

The table below shows the calculated components for different values of k . In this case $R_2=1000\Omega$ and the gain=16dB. The last column displays the maximum amplitude level on the line regarding the TS613 maximum output capabilities (18Vpp diff.) and a 1:2 line transformer ratio.

Active matching					
k	R1 (Ω)	R3 (Ω)	Rs (Ω)	TS613 Output Level to get 12.4Vpp on the line (Vpp diff)	Maximum Line level (Vpp diff)
1.3	820	1500	3.9	8	27.5
1.4	490	1600	5.1	8.7	25.7
1.5	360	2200	6.2	9.3	25.3
1.6	270	2400	7.5	9.9	23.7
1.7	240	3300	9.1	10.5	22.3
Passive matching				12.4	18

MEASUREMENT OF THE POWER CONSUMPTION IN THE ADSL APPLICATION

Conditions:

- Passive impedance matching
- Transformer turns ratio: 2
- Power Supply: 12V
- Maximum level required on the line: 12.4Vpp
- Maximum output level of the driver: 12.4Vpp
- Crest factor: 5.3 (Vp/Vrms)

The TS613 power consumption during emission on 900 and 4550 meter twisted pair telephone lines: **360mW**

PACKAGE MECHANICAL DATA
8 PINS - PLASTIC MICROPACKAGE (SO)

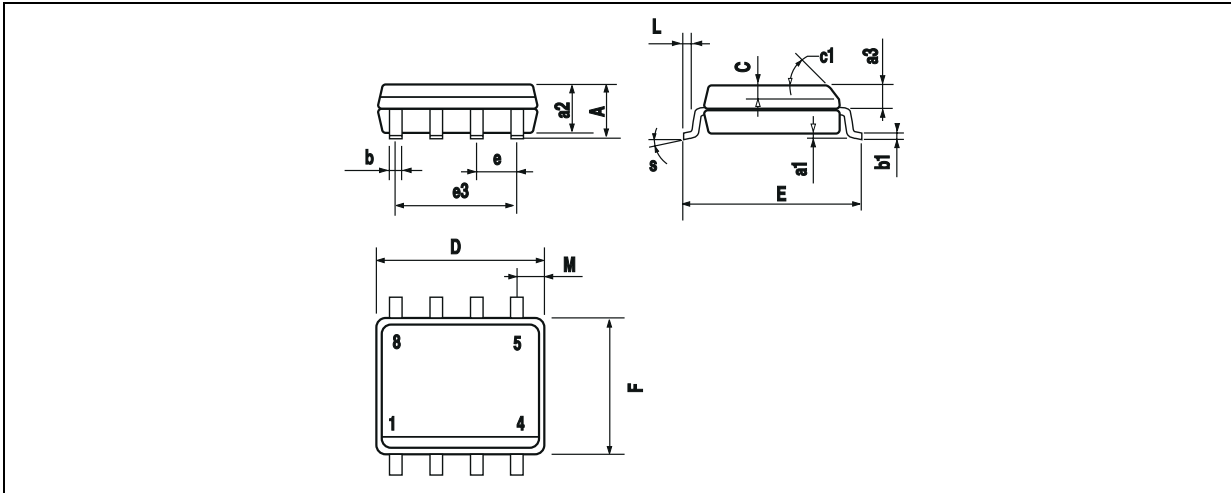

Dim.	Millimeters			Inches		
	Min.	Typ.	Max.	Min.	Typ.	Max.
A			1.75			0.069
a1	0.1		0.25	0.004		0.010
a2			1.65			0.065
a3	0.65		0.85	0.026		0.033
b	0.35		0.48	0.014		0.019
b1	0.19		0.25	0.007		0.010
C	0.25		0.5	0.010		0.020
c1	45° (typ.)					
D	4.8		5.0	0.189		0.197
E	5.8		6.2	0.228		0.244
e		1.27			0.050	
e3		3.81			0.150	
F	3.8		4.0	0.150		0.157
L	0.4		1.27	0.016		0.050
M			0.6			0.024
S	8° (max.)					

PACKAGE MECHANICAL DATA
8 PINS - PLASTIC MICROPACKAGE (SO Exposed-Pad)

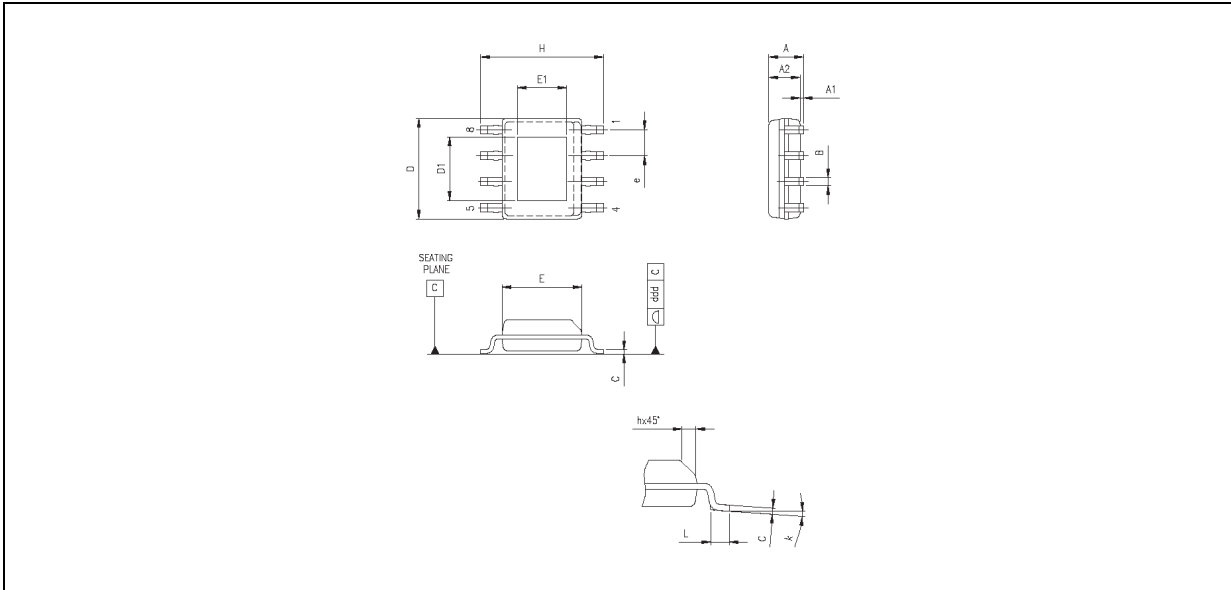

Dim.	Millimeters			Inches		
	Min.	Typ.	Max.	Min.	Typ.	Max.
A	1.350		1.750	0.053		0.069
A1	0.000		0.250	0.001		0.010
A2	1.100		1.650	0.043		0.065
B	0.330		0.510	0.013		0.020
C	0.190		0.250	0.007		0.010
D	4.800		5.000	0.189		0.197
D1		3.10			0.122	
E	3.800		4.000	0.150		0.157
E1		2.41			0.095	
e	1.270			0.050		
H	5.800		6.200	0.228		0.244
h	0.250		0.500	0.010		0.020
L	0.400		1.270	0.016		0.050
k	0d		8d	0d		8d
ddd			0.100			0.004

Information furnished is believed to be accurate and reliable. However, STMicroelectronics assumes no responsibility for the consequences of use of such information nor for any infringement of patents or other rights of third parties which may result from its use. No license is granted by implication or otherwise under any patent or patent rights of STMicroelectronics. Specifications mentioned in this publication are subject to change without notice. This publication supersedes and replaces all information previously supplied. STMicroelectronics products are not authorized for use as critical components in life support devices or systems without express written approval of STMicroelectronics.

The ST logo is a registered trademark of STMicroelectronics

© 2002 STMicroelectronics - All Rights Reserved
 STMicroelectronics GROUP OF COMPANIES

Australia - Brazil - China - Finland - France - Germany - Hong Kong - India - Italy - Japan - Malaysia - Malta - Morocco
 Singapore - Spain - Sweden - Switzerland - United Kingdom

<http://www.st.com>

