

## Input/output rail-to-rail low power operational amplifiers

### Features

- Rail-to-rail input common-mode voltage range
- Rail-to-rail output voltage swing
- Operating from 2.7 V to 12 V
- High-speed (3 MHz, 1 V/μs)
- Low consumption (0.9 mA at 3 V)
- Supply voltage rejection ratio: 80 dB
- Latch-up immunity
- Available in SOT23-5 micropackage

### Applications

- Set-top boxes
- Laptop/notebook computers
- Transformer/line drivers
- Personal entertainment (CD players)
- Portable communications (cell phones, pagers)
- Instrumentation and sensing
- Digital-to-analog converter buffers
- Portable headphone speaker drivers

### Description

The TS951, TS952 and TS954 family of devices are rail-to-rail BiCMOS operational amplifiers optimized and fully specified for 3 V and 5 V operation.

The TS951 is housed in the space-saving 5-pin SOT23 package that makes it well-suited for battery-powered systems. This micropackage simplifies the PC board design because of its ability to be placed in tight spaces (outside dimensions are: 2.8 mm x 2.9 mm).

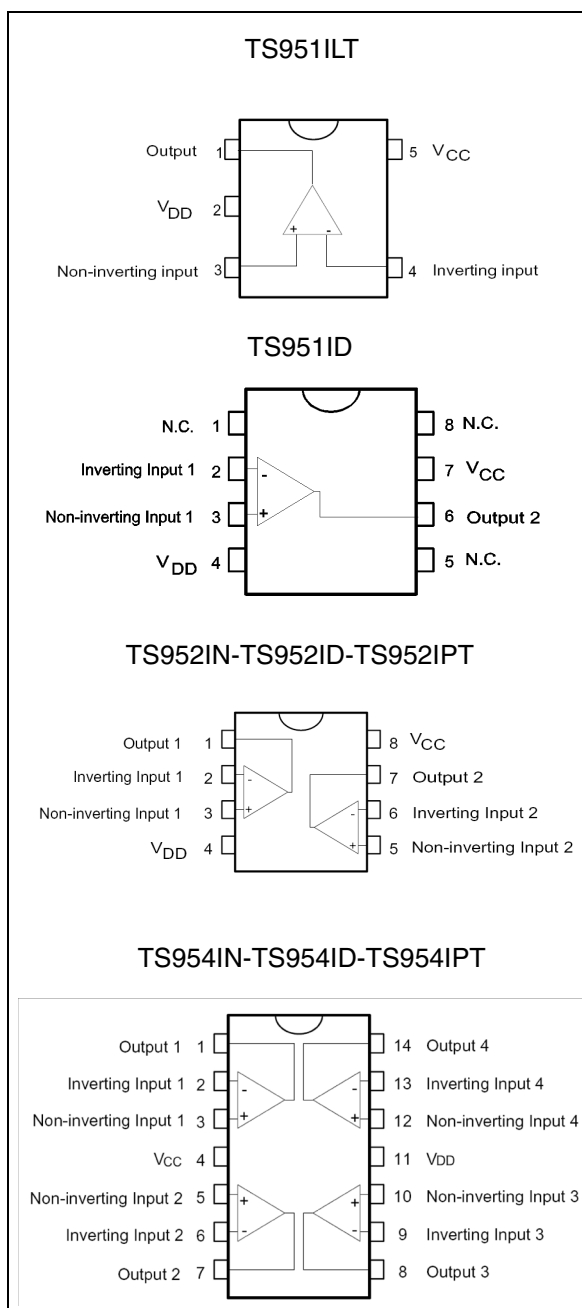

# 1 Absolute maximum ratings and operating conditions

**Table 1. Absolute maximum ratings**

Symbol	Parameter	Value	Unit
$V_{CC}$	Supply voltage <sup>(1)</sup>	14	V
$V_{id}$	Differential input voltage <sup>(2)</sup>	$\pm 1$	V
$V_{in}$	Input voltage <sup>(3)</sup>	$V_{DD}-0.3$ to $V_{CC}+0.3$	V
$T_{stg}$	Storage temperature range	-65 to +150	
$T_j$	Maximum junction temperature	150	°C
$R_{thja}$	Thermal resistance junction to ambient <sup>(4)</sup>		°C/W
	SOT23-5	250	
	SO-8	125	
	SO-14	103	
	TSSOP8 TSSOP14	120 100	
$R_{thjc}$	Thermal resistance junction to case <sup>(4)</sup>		°C/W
	SOT23-5	81	
	SO-8	40	
	SO-14	31	
	TSSOP8 TSSOP14	37 32	
ESD	HBM: human body model <sup>(5)</sup>		kV
	TS951	1	
	TS952 TS954	2 3	
	MM: machine model <sup>(6)</sup>	100	V
	CDM: charged device model <sup>(7)</sup>		kV
	TS951	1.5	
	TS952 TS954	1.5 1	
	Latch-up immunity	200	mA
	Lead temperature (soldering, 10sec)	260	°C

- All voltage values, except differential voltage are with respect to network ground terminal.
- Differential voltages are the non-inverting input terminal with respect to the inverting input terminal. If  $V_{id} > \pm 1$  V, the maximum input current must not exceed  $\pm 1$  mA. In this case ( $V_{id} > \pm 1$  V), an input series resistor must be added to limit input current.
- Do not exceed 14 V.
- Short-circuits can cause excessive heating and destructive dissipation.  $R_{th}$  are typical values.
- Human body model: a 100 pF capacitor is charged to the specified voltage, then discharged through a 1.5 k $\Omega$  resistor between two pins of the device. This is done for all couples of connected pin combinations while the other pins are floating.
- Machine model: a 200 pF capacitor is charged to the specified voltage, then discharged directly between two pins of the device with no external series resistor (internal resistor < 5  $\Omega$ ). This is done for all couples of connected pin combinations while the other pins are floating.
- Charged device model: all pins and the package are charged together to the specified voltage and then discharged directly to the ground through only one pin. This is done for all pins.

**Table 2. Operating conditions**

Symbol	Parameter	Value	Unit
$V_{CC}$	Supply voltage	2.7 to 12	V
$V_{icm}$	Common mode input voltage range	$V_{DD} - 0.2$ to $V_{CC} + 0.2$	V
$T_{oper}$	Operating free air temperature range	-40 to +125	°C

## 2 Electrical characteristics

**Table 3.**  $V_{CC} = +3\text{ V}$ ,  $V_{DD} = 0\text{ V}$ ,  $R_L$  connected to  $V_{CC}/2$ ,  $T_{amb} = 25^\circ\text{ C}$   
(unless otherwise specified)

Symbol	Parameter	Min.	Typ.	Max.	Unit
$V_{io}$	Input offset voltage $T_{min} \leq T_{amb} \leq T_{max}$			6 8	mV
$DV_{io}$	Input offset voltage drift		2		$\mu\text{V}/^\circ\text{C}$
$I_{io}$	Input offset current $T_{min} \leq T_{amb} \leq T_{max}$		1	30 80	nA
$I_{ib}$	Input bias current $V_{icm} = V_{CC}/2$ $T_{min} \leq T_{amb} \leq T_{max}$		35	100 200	nA
CMR	Common mode rejection ratio	50	80		dB
SVR	Supply voltage rejection ratio $V_{CC} = 2.7\text{ V to } 3.3\text{ V}$	60	80		dB
$A_{vd}$	Large signal voltage gain $V_o = 2 V_{pk-pk}$ , $R_L = 600\ \Omega$		80		dB
$V_{OH}$	High level output voltage $R_L = 600\ \Omega$	2.8	2.9		V
$V_{OL}$	Low level output voltage $R_L = 600\ \Omega$		80	250	mV
$I_{sc}$	Output short-circuit current	10			mA
$I_{CC}$	Supply current (per amplifier) No load, $V_{icm} = V_{CC}/2$		0.9	1.3	mA
GBP	Gain bandwidth product $R_L = 2\text{ k}\Omega$		3		MHz
SR	Slew rate		1		$\text{V}/\mu\text{s}$
$\phi_m$	Phase margin at unit gain $R_L = 600\ \Omega$ , $C_L = 100\text{ pF}$		60		Degrees
Gm	Gain margin $R_L = 600\ \Omega$ , $C_L = 100\text{ pF}$		10		dB
$e_n$	Equivalent input noise voltage $f = 1\text{ kHz}$		25		$\frac{\text{nV}}{\sqrt{\text{Hz}}}$
THD	Total harmonic distortion $V_{out} = 4 V_{pk-pk}$ , $F = 10\text{ kHz}$ , $A_V = 2$ , $R_L = 10\text{ k}\Omega$		0.01		%

**Table 4.**  $V_{CC} = +5\text{ V}$ ,  $V_{DD} = 0\text{ V}$ ,  $R_L$  connected to  $V_{CC}/2$ ,  $T_{amb} = 25^\circ\text{ C}$   
(unless otherwise specified)

Symbol	Parameter	Min.	Typ.	Max.	Unit
$V_{io}$	Input offset voltage $T_{min} \leq T_{amb} \leq T_{max}$			6 8	mV
$DV_{io}$	Input offset voltage drift		2		$\mu\text{V}/^\circ\text{C}$
$I_{io}$	Input offset current $V_{icm} = V_{CC}/2$ $T_{min} \leq T_{amb} \leq T_{max}$		1	30 80	nA
$I_{ib}$	Input bias current $V_{icm} = V_{CC}/2$ $T_{min} \leq T_{amb} \leq T_{max}$		35	100 200	nA
CMR	Common mode rejection ratio	50	80		dB
SVR	Supply voltage rejection ratio $V_{CC} = 2.7\text{ V to } 3.3\text{ V}$	60	80		dB
$A_{vd}$	Large signal voltage gain $V_o = 2\text{ V}_{pk-pk}$ , $R_L = 600\ \Omega$		86		dB
$V_{OH}$	High level output voltage $R_L = 600\ \Omega$	4.7	4.8		V
$V_{OL}$	Low level output voltage $R_L = 600\ \Omega$		80	300	mV
$I_{sc}$	Output short-circuit current	10			mA
$I_{CC}$	Supply current (per amplifier) No load, $V_{icm} = V_{CC}/2$		0.95	1.4	mA
GBP	Gain bandwidth product $R_L = 2\text{ k}\Omega$		3		MHz
SR	Slew rate		1		$\text{V}/\mu\text{s}$
$\phi_m$	Phase margin at unit gain $R_L = 600\ \Omega$ , $C_L = 100\text{ pF}$		60		Degrees
Gm	Gain margin $R_L = 600\ \Omega$ , $C_L = 100\text{ pF}$		10		dB
$e_n$	Equivalent input noise voltage $f = 1\text{ kHz}$		25		$\frac{\text{nV}}{\sqrt{\text{Hz}}}$
THD	Total harmonic distortion $V_{out} = 4\text{ V}_{pk-pk}$ , $F = 10\text{ kHz}$ , $A_V = 2$ , $R_L = 10\text{ k}\Omega$		0.01		%

Figure 1. Supply current vs. supply voltage

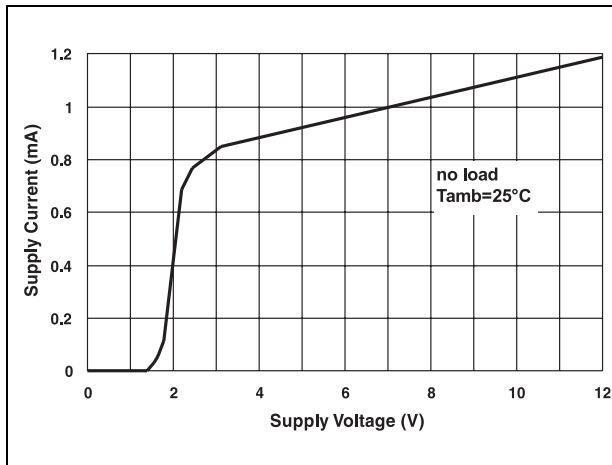

Figure 2. Output short circuit current vs. output voltage

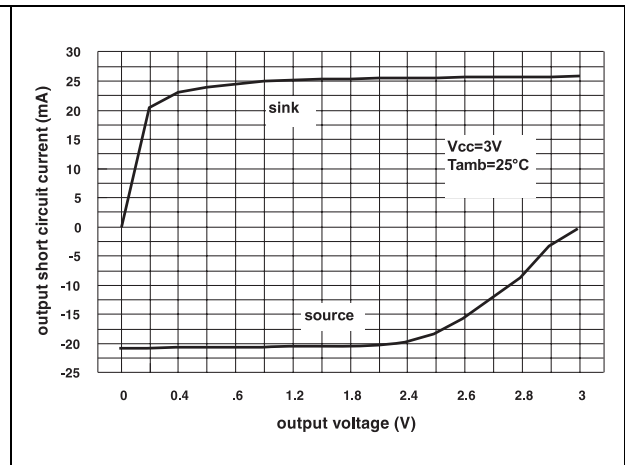

Figure 3. Voltage gain and phase vs. frequency

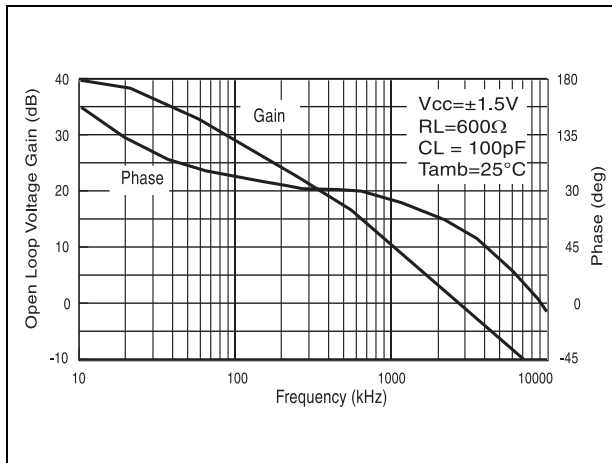

Figure 4. Supply current vs. temperature

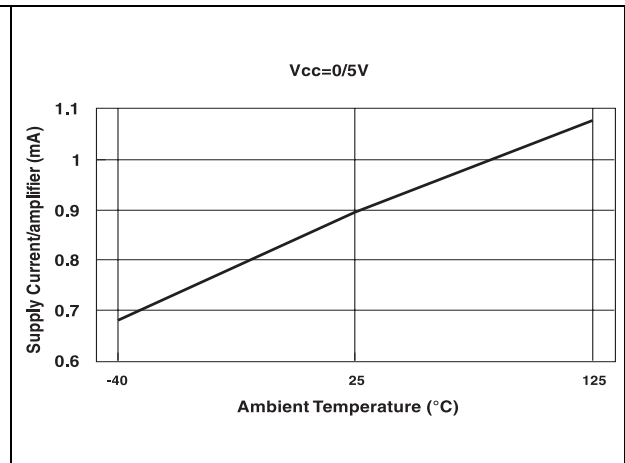

Figure 5. Output short circuit current vs. temperature

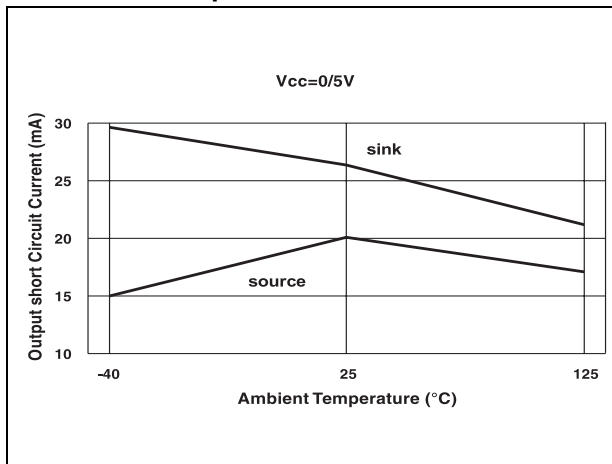

Figure 6. Slew rate vs. temperature

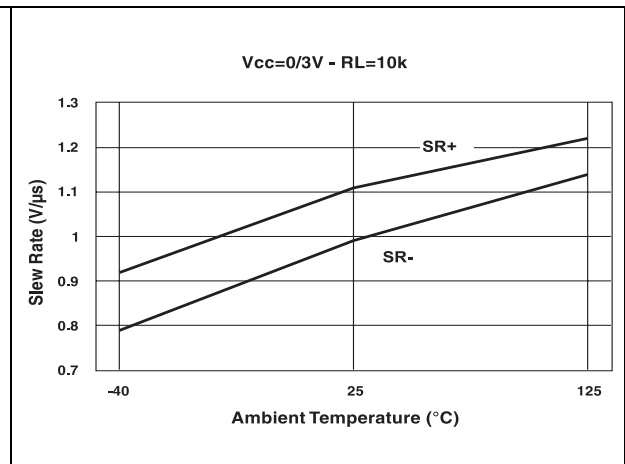

Figure 7. THD + noise vs.  $V_{out}$

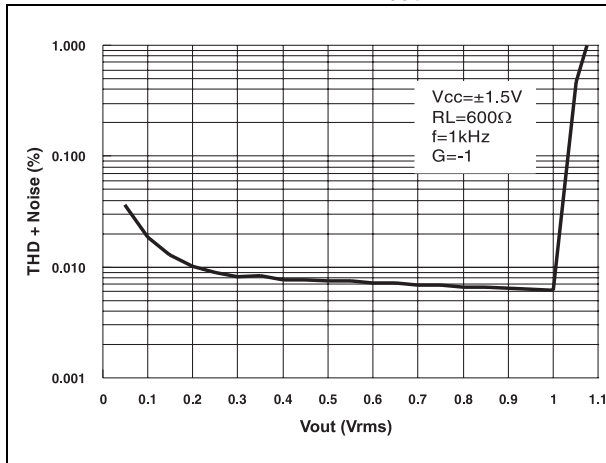

Figure 8. THD + noise vs. frequency

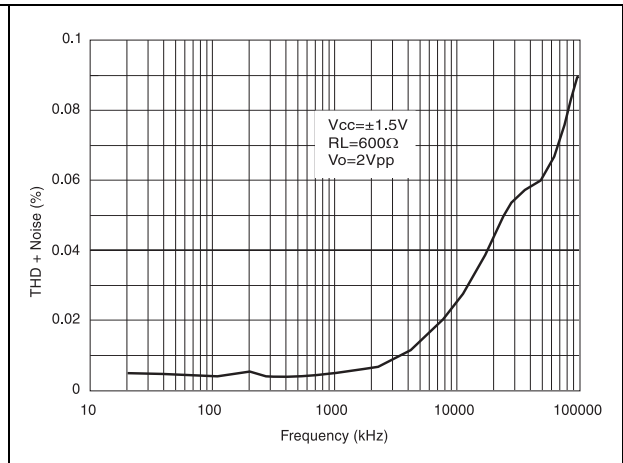

Figure 9. THD + noise vs.  $V_{out}$

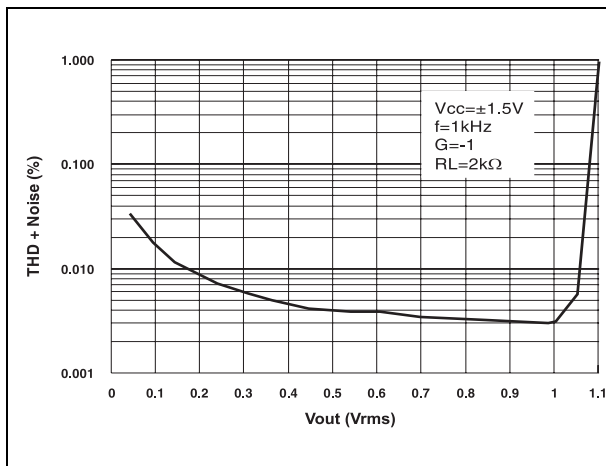
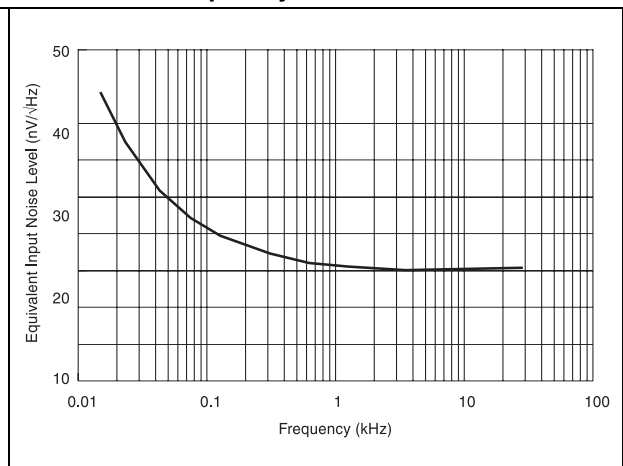

Figure 10. Equivalent input noise voltage vs. frequency



### 3 Package information

In order to meet environmental requirements, ST offers these devices in different grades of ECOPACK<sup>®</sup> packages, depending on their level of environmental compliance. ECOPACK<sup>®</sup> specifications, grade definitions and product status are available at: [www.st.com](http://www.st.com). ECOPACK<sup>®</sup> is an ST trademark.



### 3.1 SOT23-5 package information

Figure 11. SOT23-5 package mechanical drawing

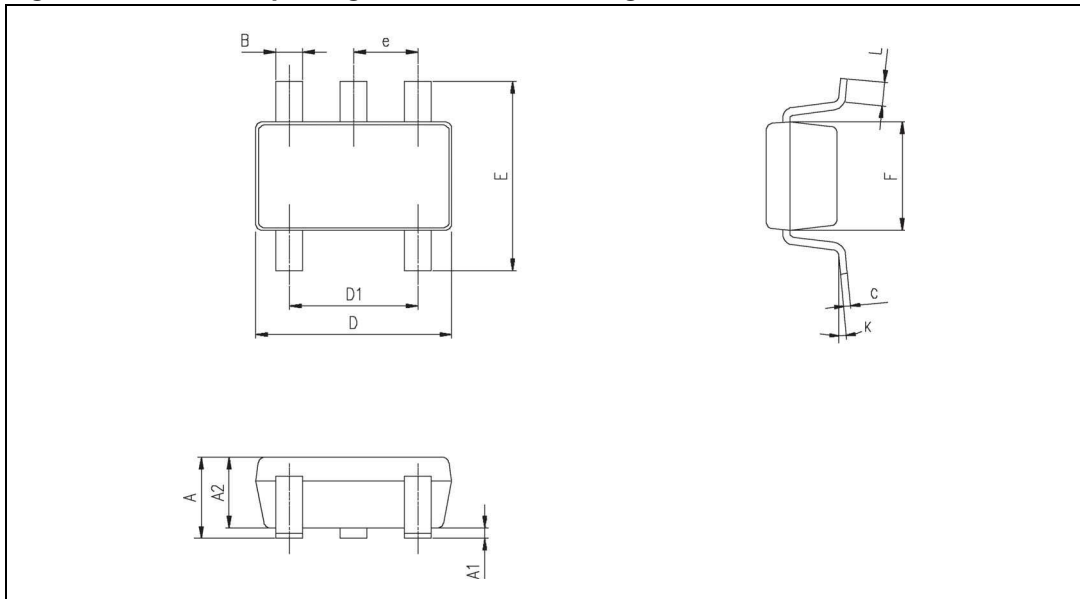

Table 5. SOT23-5 package mechanical data

Ref.	Dimensions					
	Millimeters			Inches		
	Min.	Typ.	Max.	Min.	Typ.	Max.
A	0.90	1.20	1.45	0.035	0.047	0.057
A1			0.15			0.006
A2	0.90	1.05	1.30	0.035	0.041	0.051
B	0.35	0.40	0.50	0.013	0.015	0.019
C	0.09	0.15	0.20	0.003	0.006	0.008
D	2.80	2.90	3.00	0.110	0.114	0.118
D1		1.90			0.075	
e		0.95			0.037	
E	2.60	2.80	3.00	0.102	0.110	0.118
F	1.50	1.60	1.75	0.059	0.063	0.069
L	0.10	0.35	0.60	0.004	0.013	0.023
K	0 degrees		10 degrees			

### 3.2 DIP8 package information

Figure 12. DIP8 package mechanical drawing

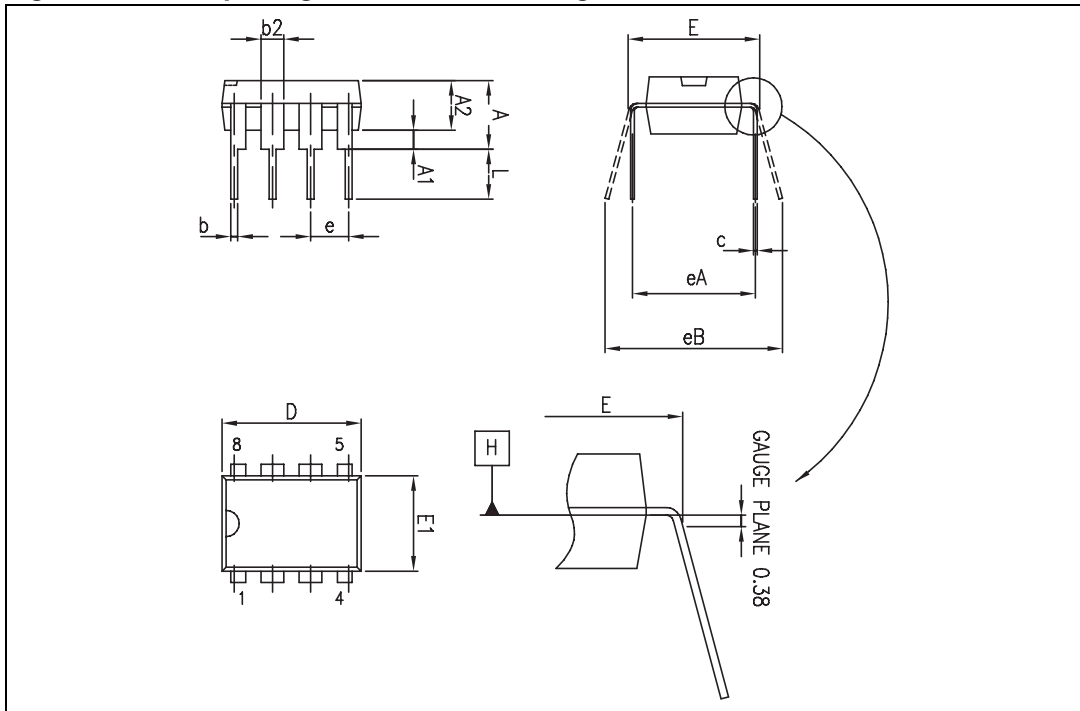

Table 6. DIP8 package mechanical data

Ref.	Dimensions					
	Millimeters			Inches		
	Min.	Typ.	Max.	Min.	Typ.	Max.
A			5.33			0.210
A1	0.38			0.015		
A2	2.92	3.30	4.95	0.115	0.130	0.195
b	0.36	0.46	0.56	0.014	0.018	0.022
b2	1.14	1.52	1.78	0.045	0.060	0.070
c	0.20	0.25	0.36	0.008	0.010	0.014
D	9.02	9.27	10.16	0.355	0.365	0.400
E	7.62	7.87	8.26	0.300	0.310	0.325
E1	6.10	6.35	7.11	0.240	0.250	0.280
e		2.54			0.100	
eA		7.62			0.300	
eB			10.92			0.430
L	2.92	3.30	3.81	0.115	0.130	0.150

### 3.3 SO-8 package information

Figure 13. SO-8 package mechanical drawing

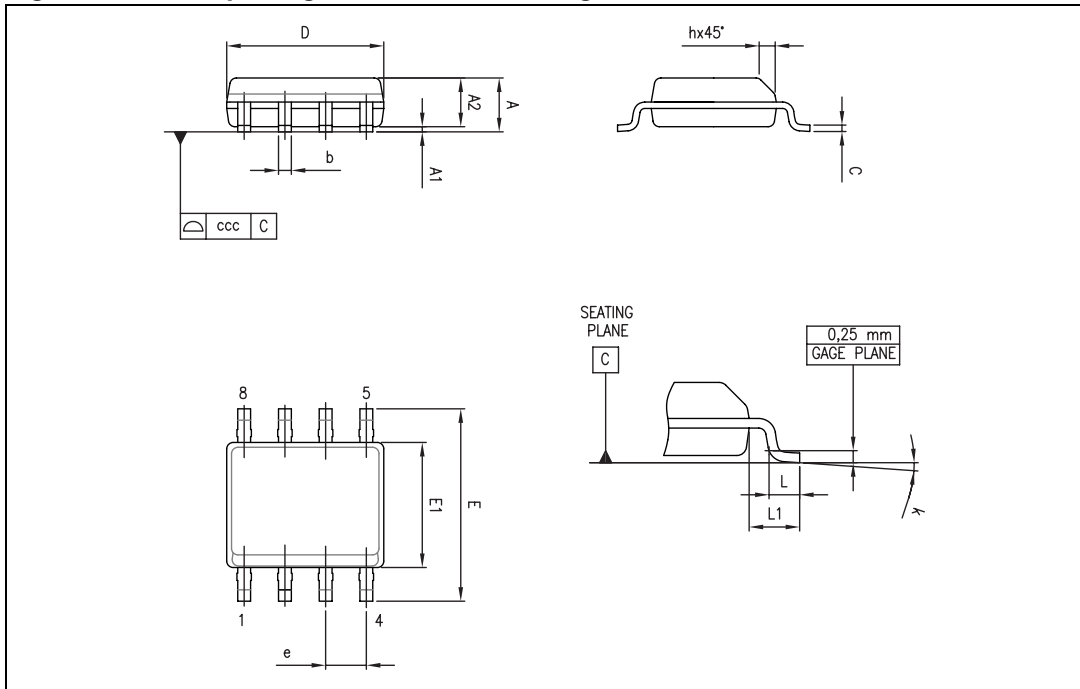

Table 7. SO-8 package mechanical data

Ref.	Dimensions					
	Millimeters			Inches		
	Min.	Typ.	Max.	Min.	Typ.	Max.
A			1.75			0.069
A1	0.10		0.25	0.004		0.010
A2	1.25			0.049		
b	0.28		0.48	0.011		0.019
c	0.17		0.23	0.007		0.010
D	4.80	4.90	5.00	0.189	0.193	0.197
E	5.80	6.00	6.20	0.228	0.236	0.244
E1	3.80	3.90	4.00	0.150	0.154	0.157
e		1.27			0.050	
h	0.25		0.50	0.010		0.020
L	0.40		1.27	0.016		0.050
L1		1.04			0.040	
k	1°		8°	1°		8°
ccc			0.10			0.004

### 3.4 TSSOP8 package information

Figure 14. TSSOP8 package mechanical drawing

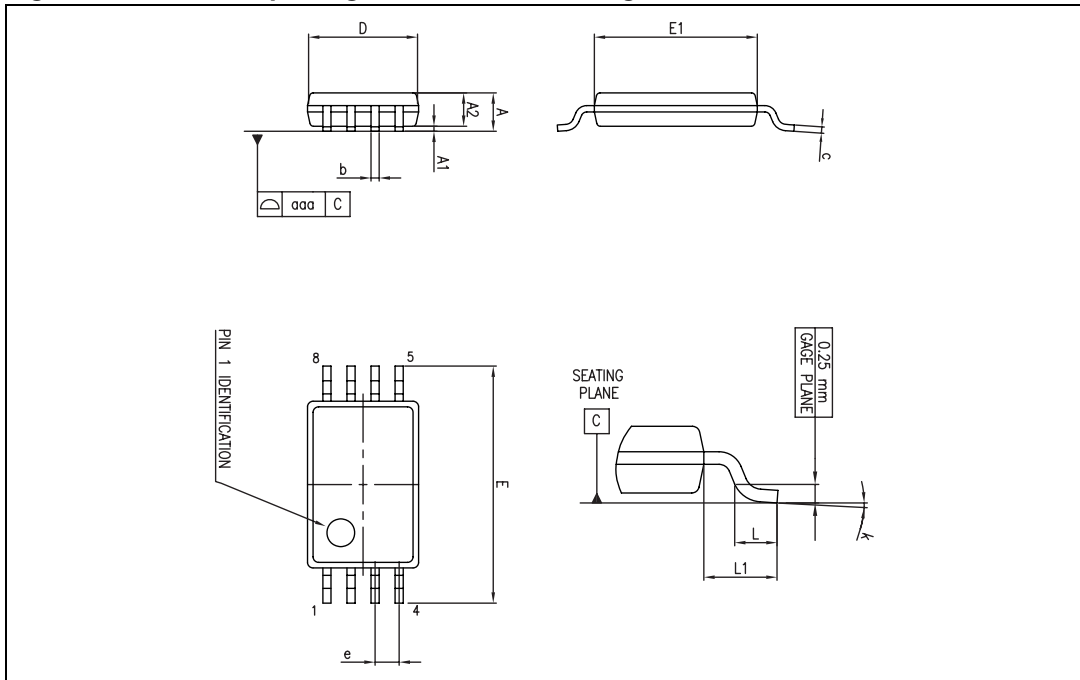

Table 8. TSSOP8 package mechanical data

Ref.	Dimensions					
	Millimeters			Inches		
	Min.	Typ.	Max.	Min.	Typ.	Max.
A			1.20			0.047
A1	0.05		0.15	0.002		0.006
A2	0.80	1.00	1.05	0.031	0.039	0.041
b	0.19		0.30	0.007		0.012
c	0.09		0.20	0.004		0.008
D	2.90	3.00	3.10	0.114	0.118	0.122
E	6.20	6.40	6.60	0.244	0.252	0.260
E1	4.30	4.40	4.50	0.169	0.173	0.177
e		0.65			0.0256	
k	0°		8°	0°		8°
L	0.45	0.60	0.75	0.018	0.024	0.030
L1		1			0.039	
aaa			0.10			0.004

### 3.5 DIP14 package information

Figure 15. DIP14 package mechanical drawing

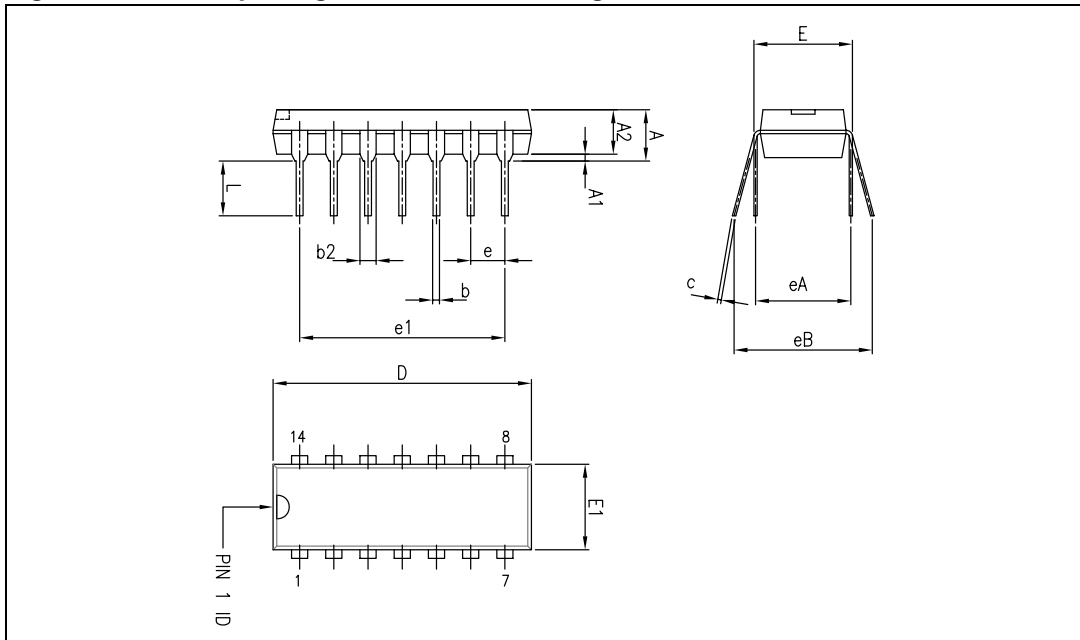

Table 9. DIP14 package mechanical data

Dimensions						
Ref.	Millimeters			Inches		
	Min.	Typ.	Max.	Min.	Typ.	Max.
A			5.33			0.21
A1	0.38			0.015		
A2	2.92	3.30	4.95	0.11	0.13	0.19
b	0.36	0.46	0.56	0.014	0.018	0.022
b2	1.14	1.52	1.78	0.04	0.06	0.07
c	0.20	0.25	0.36	0.007	0.009	0.01
D	18.67	19.05	19.69	0.73	0.75	0.77
E	7.62	7.87	8.26	0.30	0.31	0.32
E1	6.10	6.35	7.11	0.24	0.25	0.28
e		2.54			0.10	
e1		15.24			0.60	
eA		7.62			0.30	
eB			10.92			0.43
L	2.92	3.30	3.81	0.11	0.13	0.15

### 3.6 SO-14 package information

Figure 16. SO-14 package mechanical drawing

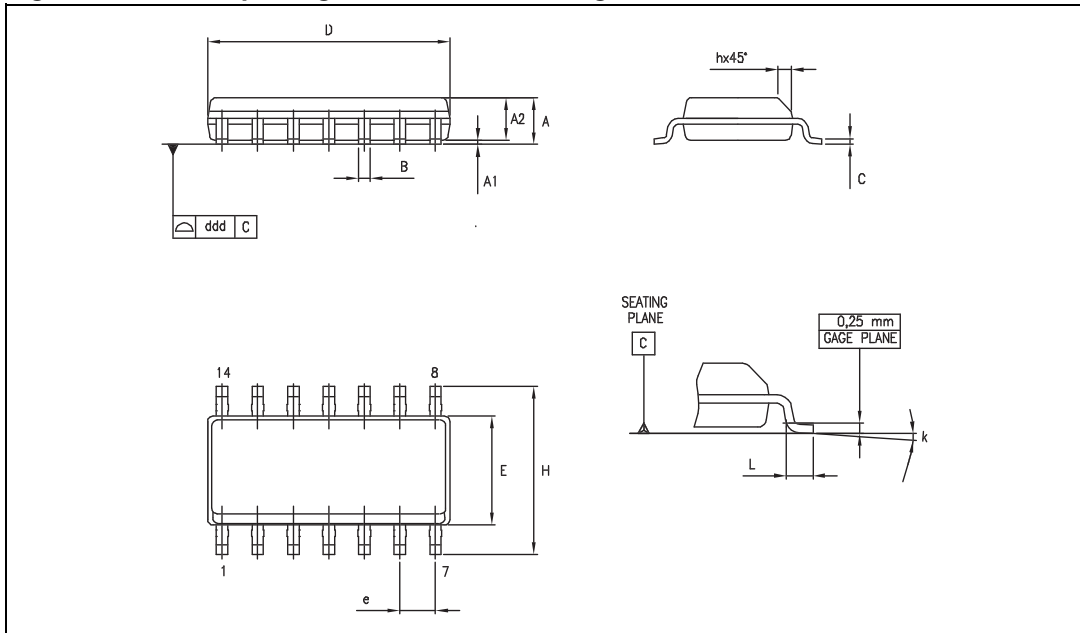

Table 10. SO-14 package mechanical data

Dimensions						
Ref.	Millimeters			Inches		
	Min.	Typ.	Max.	Min.	Typ.	Max.
A	1.35		1.75	0.05		0.068
A1	0.10		0.25	0.004		0.009
A2	1.10		1.65	0.04		0.06
B	0.33		0.51	0.01		0.02
C	0.19		0.25	0.007		0.009
D	8.55		8.75	0.33		0.34
E	3.80		4.0	0.15		0.15
e		1.27			0.05	
H	5.80		6.20	0.22		0.24
h	0.25		0.50	0.009		0.02
L	0.40		1.27	0.015		0.05
k	8° (max.)					
ddd			0.10			0.004

### 3.7 TSSOP14 package information

Figure 17. TSSOP14 package mechanical drawing

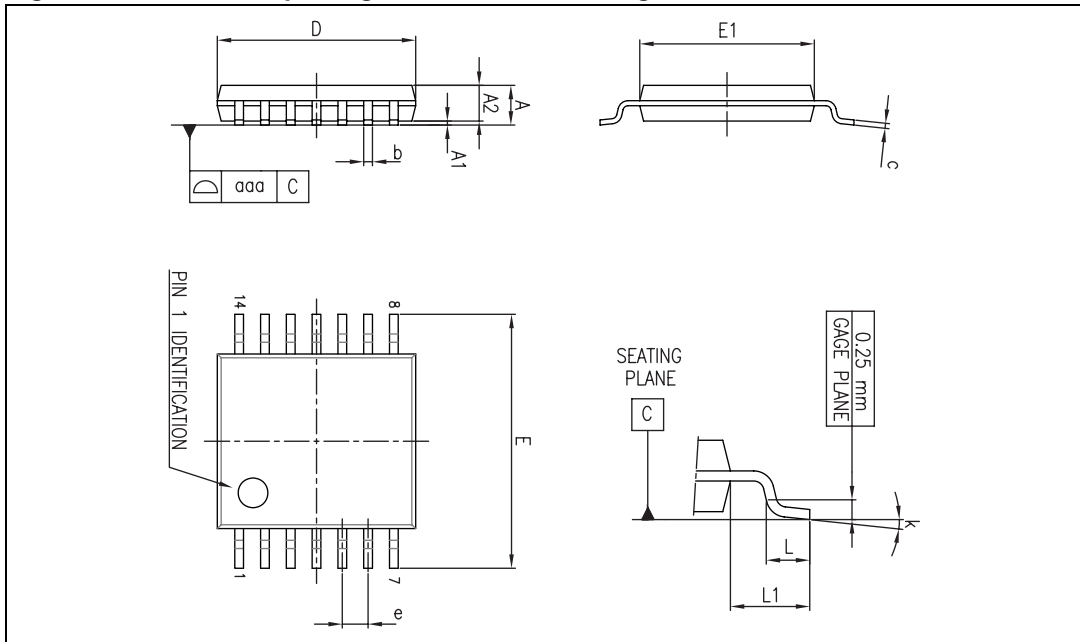

Table 11. TSSOP14 package mechanical data

Ref.	Dimensions					
	Millimeters			Inches		
	Min.	Typ.	Max.	Min.	Typ.	Max.
A			1.20			0.047
A1	0.05		0.15	0.002	0.004	0.006
A2	0.80	1.00	1.05	0.031	0.039	0.041
b	0.19		0.30	0.007		0.012
c	0.09		0.20	0.004		0.0089
D	4.90	5.00	5.10	0.193	0.197	0.201
E	6.20	6.40	6.60	0.244	0.252	0.260
E1	4.30	4.40	4.50	0.169	0.173	0.176
e		0.65			0.0256	
L	0.45	0.60	0.75	0.018	0.024	0.030
L1		1.00			0.039	
k	0°		8°	0°		8°
aaa			0.10			0.004

## 4 Ordering information

**Table 12. Order codes**

Order code	Temperature range	Package	Packing	Marking
TS951ID TS951IDT	-40°C to +125°C	SO-8	Tube or Tape & reel	951I
TS951ILT		SOT23-5L	Tape & reel	K10I
TS951IYLT <sup>(1)</sup>		SOT23-5L (Automotive grade)		K1A2
TS952IN		DIP8	Tube	TS952IN
TS952ID TS952IDT		SO-8	Tube or Tape & reel	952I
TS952IYD <sup>(1)</sup> TS952IYDT <sup>(1)</sup>		SO-8 (Automotive grade)		952IY
TS952IPT		TSSOP8	Tape & reel	952I
TS952IYPT <sup>(2)</sup>		TSSOP8 (Automotive grade)		952Y
TS954IN		DIP14	Tube	TS954IN
TS954ID TS954IDT		SO-14	Tube or Tape & reel	954I
TS954IYD <sup>(1)</sup> TS954IYDT <sup>(1)</sup>		SO-14 (Automotive grade)		954IY
TS954IPT		TSSOP14	Tape & reel	954I
TS954IYPT <sup>(2)</sup>		TSSOP14 (Automotive grade)		954Y

1. Qualified and characterized according to AEC Q100 and Q003 or equivalent, advanced screening according to AEC Q001 & Q 002 or equivalent.
2. Qualification and characterization according to AEC Q100 and Q003 or equivalent, advanced screening according to AEC Q001 & Q 002 or equivalent are on-going.



## 5 Revision history

**Table 13. Document revision history**

Date	Revision	Changes
01-May-2001	1	Initial release.
02-Jan-2005	2	Modifications on AMR <a href="#">Table 1 on page 2</a> (explanation of $V_{id}$ and $V_i$ limits, ESD MM and CDM values added, $R_{thja}$ added).
03-Jul-2005	3	PPAP references inserted in the datasheet see <a href="#">Table 12: Order codes</a> .
04-Aug-2005	4	Table data was badly formatted, see <a href="#">Table 4 on page 5</a> .
15-Dec-2005	5	TS951IYLT PPAP reference added, see <a href="#">Table 12: Order codes</a> .
10-Dec-2007	6	Added missing order codes, and automotive grade status in <a href="#">Table 12: Order codes</a> . Updated footnotes for ESD parameters in <a href="#">Table 1: Absolute maximum ratings</a> . Reformatted package information.
10-Mar-2009	7	Removed TS951IN and TS951IYD/DT from <a href="#">Table 12: Order codes</a> .
24-Feb-2011	8	Changed TS951IYLT marking and updated automotive grade status in <a href="#">Table 12: Order codes</a> .

**Please Read Carefully:**

Information in this document is provided solely in connection with ST products. STMicroelectronics NV and its subsidiaries ("ST") reserve the right to make changes, corrections, modifications or improvements, to this document, and the products and services described herein at any time, without notice.

All ST products are sold pursuant to ST's terms and conditions of sale.

Purchasers are solely responsible for the choice, selection and use of the ST products and services described herein, and ST assumes no liability whatsoever relating to the choice, selection or use of the ST products and services described herein.

No license, express or implied, by estoppel or otherwise, to any intellectual property rights is granted under this document. If any part of this document refers to any third party products or services it shall not be deemed a license grant by ST for the use of such third party products or services, or any intellectual property contained therein or considered as a warranty covering the use in any manner whatsoever of such third party products or services or any intellectual property contained therein.

**UNLESS OTHERWISE SET FORTH IN ST'S TERMS AND CONDITIONS OF SALE ST DISCLAIMS ANY EXPRESS OR IMPLIED WARRANTY WITH RESPECT TO THE USE AND/OR SALE OF ST PRODUCTS INCLUDING WITHOUT LIMITATION IMPLIED WARRANTIES OF MERCHANTABILITY, FITNESS FOR A PARTICULAR PURPOSE (AND THEIR EQUIVALENTS UNDER THE LAWS OF ANY JURISDICTION), OR INFRINGEMENT OF ANY PATENT, COPYRIGHT OR OTHER INTELLECTUAL PROPERTY RIGHT.**

**UNLESS EXPRESSLY APPROVED IN WRITING BY AN AUTHORIZED ST REPRESENTATIVE, ST PRODUCTS ARE NOT RECOMMENDED, AUTHORIZED OR WARRANTED FOR USE IN MILITARY, AIR CRAFT, SPACE, LIFE SAVING, OR LIFE SUSTAINING APPLICATIONS, NOR IN PRODUCTS OR SYSTEMS WHERE FAILURE OR MALFUNCTION MAY RESULT IN PERSONAL INJURY, DEATH, OR SEVERE PROPERTY OR ENVIRONMENTAL DAMAGE. ST PRODUCTS WHICH ARE NOT SPECIFIED AS "AUTOMOTIVE GRADE" MAY ONLY BE USED IN AUTOMOTIVE APPLICATIONS AT USER'S OWN RISK.**

Resale of ST products with provisions different from the statements and/or technical features set forth in this document shall immediately void any warranty granted by ST for the ST product or service described herein and shall not create or extend in any manner whatsoever, any liability of ST.

ST and the ST logo are trademarks or registered trademarks of ST in various countries.

Information in this document supersedes and replaces all information previously supplied.

The ST logo is a registered trademark of STMicroelectronics. All other names are the property of their respective owners.

© 2011 STMicroelectronics - All rights reserved

STMicroelectronics group of companies

Australia - Belgium - Brazil - Canada - China - Czech Republic - Finland - France - Germany - Hong Kong - India - Israel - Italy - Japan - Malaysia - Malta - Morocco - Philippines - Singapore - Spain - Sweden - Switzerland - United Kingdom - United States of America

[www.st.com](http://www.st.com)