

Rail-to-rail high output current single operational amplifier

Datasheet – production data

Features

- Rail-to-rail input and output
- Low noise: 9 nV/√Hz
- Low distortion
- High output current: 80 mA (able to drive 32 Ω loads)
- High-speed: 4 MHz, 1 V/μs
- Operating from 2.7 V to 12 V
- ESD internal protection: 1.5 kV
- Latch-up immunity
- Macromodel included in this specification

Applications

- Headphone amplifier
- Piezoelectric speaker driver
- Sound cards, multimedia systems
- Line driver, actuator driver
- Servo amplifier
- Mobile phone and portable communication sets
- Instrumentation with low noise as key factor

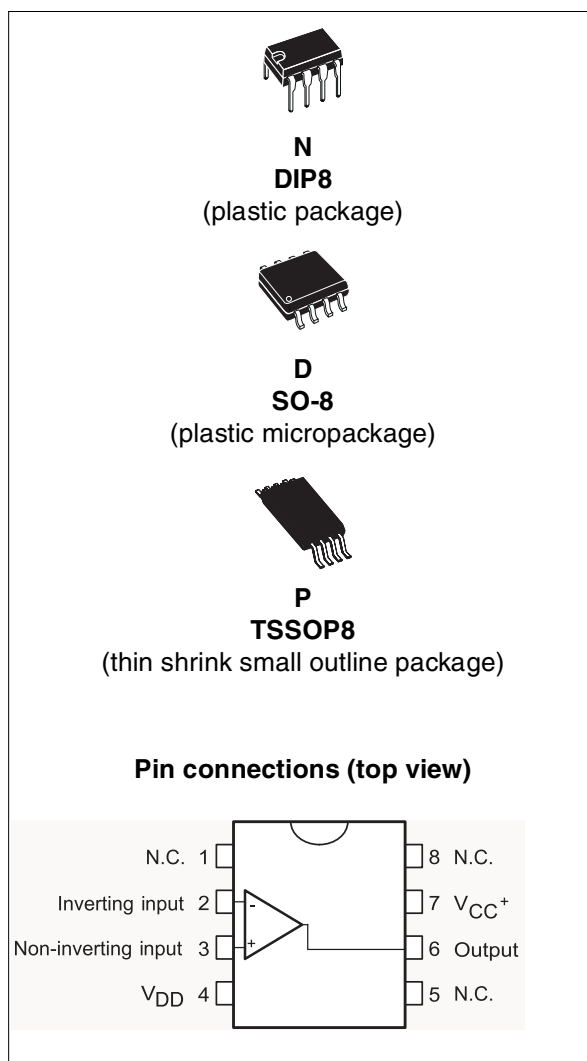
Table 1. Device summary

Order code	Temperature range	Package	Packing	Marking
TS921IN	-40 °C, +125 °C	DIP8	Tube	TS921IN
TS921ID/IDT		SO-8	Tube or tape and reel	9211
TS921IPT		TSSOP8 (thin shrink outline package)	Tape and reel	

1 Description

The TS921 device is a rail-to-rail single BiCMOS operational amplifier optimized and fully specified for 3 V and 5 V operation.

Its high output current allows low load impedances to be driven.

The TS921 device exhibits very low noise, low distortion and low offset. It has a high output current capability which makes this device an excellent choice for high quality, low voltage or battery operated audio systems.

The device is stable for capacitive loads up to 500 pF.

2 Absolute maximum ratings

Table 2. Key parameters and their absolute maximum ratings

Symbol	Parameter	Condition	Value	Unit
V_{CC}	Supply voltage ⁽¹⁾		14	V
V_{id}	Differential input voltage ⁽²⁾		± 1	V
V_i	Input voltage		$V_{DD} - 0.3$ to $V_{CC} + 0.3$	V
T_{stg}	Storage temperature		-65 to +150	°C
T_j	Maximum junction temperature		150	°C
R_{thja}	Thermal resistance junction-to-ambient	SO-8	125	°C/W
		TSSOP8	120	
		DIP8	85	
R_{thjc}	Thermal resistance junction-to-case	SO-8	40	°C/W
		TSSOP8	37	
		DIP8	41	
ESD	Electrostatic discharge	HBM Human body model ⁽³⁾	1.5	kV
		MM Machine model ⁽⁴⁾	100	V
		CDM Charged device model	1.5	kV
	Output short-circuit duration		See ⁽⁵⁾	
	Latch-up immunity		200	mA
	Soldering temperature	10 sec., standard package	250	°C
		10 sec., lead-free package	260	

1. All voltage values, except differential voltage are with respect to network ground terminal.
2. Differential voltages are the non-inverting input terminal with respect to the inverting input terminal. If $V_{id} > \pm 1$ V, the maximum input current must not exceed ± 1 mA. In this case ($V_{id} > \pm 1$ V) an input serie resistor must be added to limit input current.
3. Human body model, 100 pF discharged through a 1.5 k Ω resistor into pin of device.
4. Machine model ESD, a 200 pF cap is charged to the specified voltage, then discharged directly into the IC with no external series resistor (internal resistor < 5 Ω), into pin to pin of device.
5. There is no short-circuit protection inside the device: short-circuits from the output to V_{CC} can cause excessive heating. The maximum output current is approximately 80 mA, independent of the magnitude of V_{CC} . Destructive dissipation can result from simultaneous short-circuits on all amplifiers.

Table 3. Operating conditions

Symbol	Parameter	Value	Unit
V_{CC}	Supply voltage	2.7 to 12	V
V_{icm}	Common mode input voltage range	$V_{DD} - 0.2$ to $V_{CC} + 0.2$	V
T_{oper}	Operating free air temperature range	-40 to +125	°C

3 Electrical characteristics

Table 4. Electrical characteristics for $V_{CC} = 3\text{ V}$, $V_{DD} = 0\text{ V}$, $V_{icm} = V_{CC}/2$, R_L connected to $V_{CC}/2$, $T_{amb} = 25\text{ °C}$ (unless otherwise specified)

Symbol	Parameter	Conditions	Min.	Typ.	Max.	Unit
V_{io}	Input offset voltage	at $T_{min.} \leq T_{amb} \leq T_{max}$			3 5	mV
ΔV_{io}	Input offset voltage drift			2		$\mu\text{V}/\text{°C}$
I_{io}	Input offset current	$V_{out} = 1.5\text{ V}$		1	30	nA
I_{ib}	Input bias current	$V_{out} = 1.5\text{ V}$		15	100	nA
V_{OH}	High level output voltage	$R_L = 600\ \Omega$ $R_L = 32\ \Omega$	2.87	2.63		V
V_{OL}	Low level output voltage	$R_L = 600\ \Omega$ $R_L = 32\ \Omega$		180	100	mV
A_{vd}	Large signal voltage gain	$V_{out} = 2\ V_{pk-pk}$ $R_L = 600\ \Omega$ $R_L = 32\ \Omega$		35 16		V/mV
GBP	Gain bandwidth product	$R_L = 600\ \Omega$		4		MHz
I_{CC}	Supply current	No load, $V_{out} = V_{CC}/2$		1	1.5	mA
CMR	Common mode rejection ratio		60	80		dB
SVR	Supply voltage rejection ratio	$V_{CC} = 2.7\text{ to }3.3\text{ V}$	60	80		dB
I_o	Output short-circuit current		50	80		mA
SR	Slew rate		0.7	1.3		V/ μs
Pm	Phase margin at unit gain	$R_L = 600\ \Omega$, $C_L = 100\ \text{pF}$		68		Degrees
GM	Gain margin	$R_L = 600\ \Omega$, $C_L = 100\ \text{pF}$		12		dB
e_n	Equivalent input noise voltage	$f = 1\ \text{kHz}$		9		$\frac{\text{nV}}{\sqrt{\text{Hz}}}$
THD	Total harmonic distortion	$V_{out} = 2\ V_{pk-pk}$, $f = 1\ \text{kHz}$, $A_v = 1$, $R_L = 600\ \Omega$		0.005		%

Table 5. Electrical characteristics for $V_{CC} = 5\text{ V}$, $V_{DD} = 0\text{ V}$, $V_{icm} = V_{CC}/2$, R_L connected to $V_{CC}/2$, $T_{amb} = 25\text{ °C}$ (unless otherwise specified)

Symbol	Parameter	Conditions	Min.	Typ.	Max.	Unit
V_{io}	Input offset voltage	at $T_{min.} \leq T_{amb} \leq T_{max}$			3 5	mV
ΔV_{io}	Input offset voltage drift			2		$\mu\text{V}/\text{°C}$
I_{io}	Input offset current	$V_{out} = 1.5\text{ V}$		1	30	nA
I_{ib}	Input bias current	$V_{out} = 1.5\text{ V}$		15	100	nA
V_{OH}	High level output voltage	$R_L = 600\ \Omega$ $R_L = 32\ \Omega$	4.85	4.4		V
V_{OL}	Low level output voltage	$R_L = 600\ \Omega$ $R_L = 32\ \Omega$		300	120	mV
A_{vd}	Large signal voltage gain	$V_{out} = 2\ V_{pk-pk}$ $R_L = 600\ \Omega$ $R_L = 32\ \Omega$		35 16		V/mV
GBP	Gain bandwidth product	$R_L = 600\ \Omega$		4		MHz
I_{CC}	Supply current	No load, $V_{out} = V_{CC}/2$		1	1.5	mA
CMR	Common mode rejection ratio		60	80		dB
SVR	Supply voltage rejection ratio	$V_{CC} = 4.5\text{ to }5.5\text{ V}$	60	80		dB
I_o	Output short-circuit current		50	80		mA
SR	Slew rate		0.7	1.3		V/ μs
Pm	Phase margin at unit gain	$R_L = 600\ \Omega$, $C_L = 100\ \text{pF}$		68		Degrees
GM	Gain margin	$R_L = 600\ \Omega$, $C_L = 100\ \text{pF}$		12		dB
e_n	Equivalent input noise voltage	$f = 1\ \text{kHz}$		9		$\frac{\text{nV}}{\sqrt{\text{Hz}}}$
THD	Total harmonic distortion	$V_{out} = 2\ V_{pk-pk}$, $f = 1\ \text{kHz}$, $A_v = 1$, $R_L = 600\ \Omega$		0.005		%

Figure 1. Output short-circuit vs. output voltage ($V_{CC} = 5\text{ V}$, $V_{DD} = 0\text{ V}$)

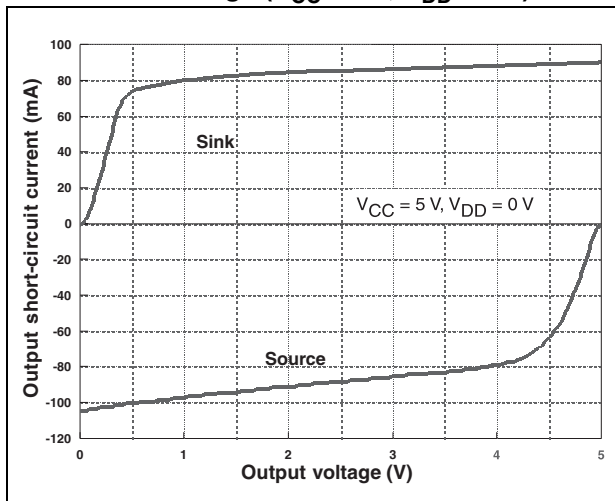

Figure 2. Voltage gain and phase vs. frequency ($R_L = 10\text{ k}\Omega$, $C_L = 100\text{ pF}$)

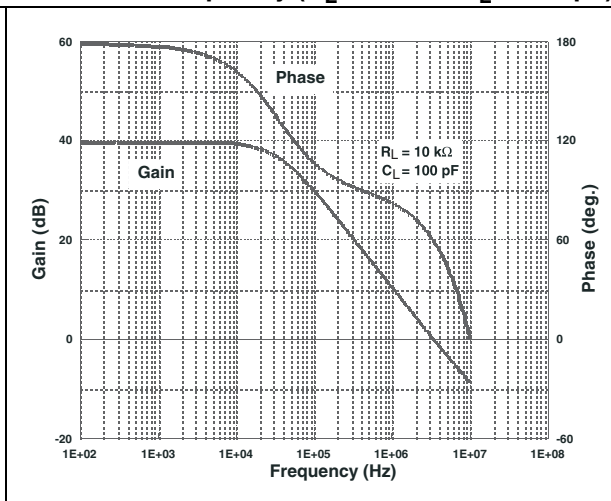

Figure 3. Output short-circuit vs. output voltage ($V_{CC} = 3\text{ V}$, $V_{DD} = 0\text{ V}$)

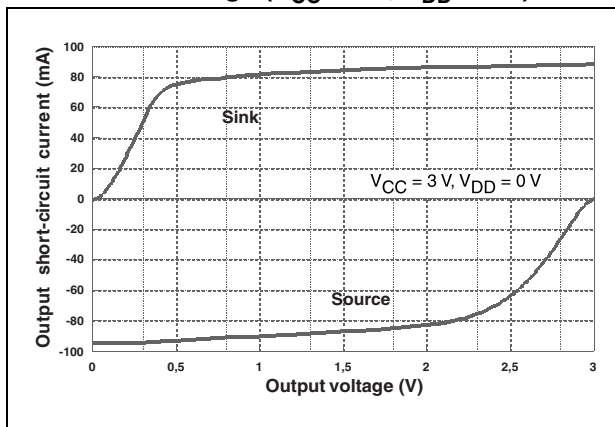

Figure 4. Equivalent input noise voltage vs. frequency ($V_{CC} = \pm 1.5\text{ V}$, $R_L = 100\ \Omega$)

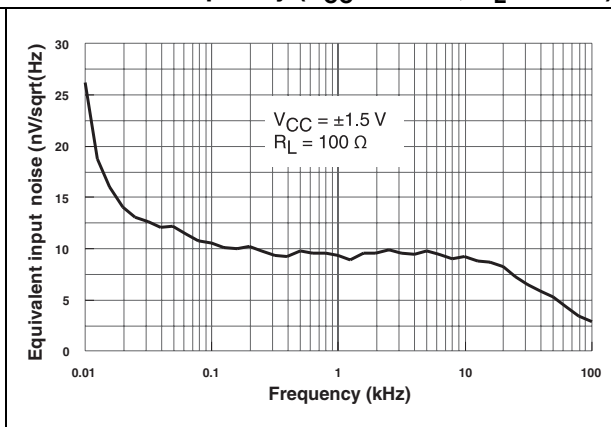

Figure 5. Output supply current vs. supply voltage

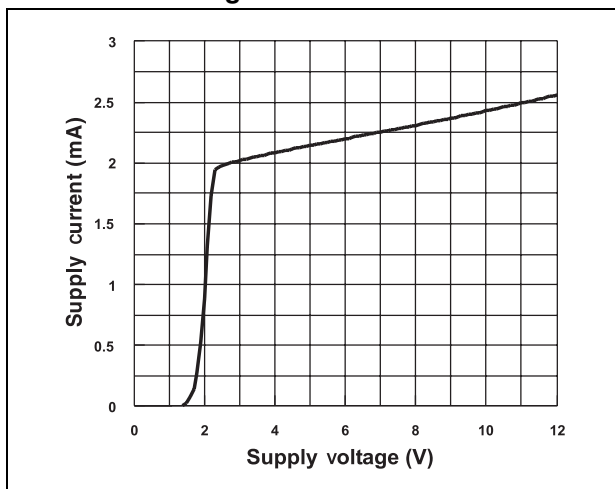

Figure 6. THD + noise vs. frequency ($R_L = 2\text{ k}\Omega$, $V_o = 10\text{ Vpp}$, $V_{CC} = \pm 6\text{ V}$, $A_v = 1$)

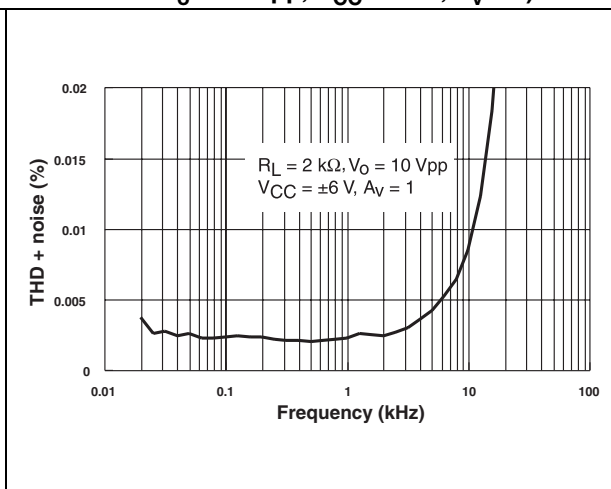

Figure 7. THD + noise vs. frequency
 ($R_L = 32 \Omega$, $V_O = 4 \text{ Vpp}$,
 $V_{CC} = \pm 2.5 \text{ V}$, $A_V = 1$)

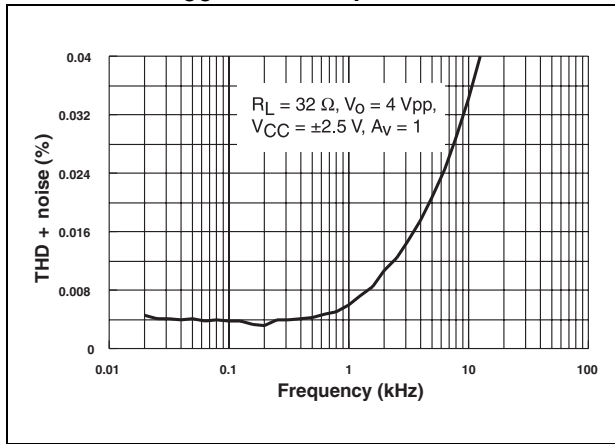

Figure 8. THD + noise vs. output voltage
 ($R_L = 600 \Omega$, $f = 1 \text{ kHz}$,
 $V_{CC} = 0/3 \text{ V}$, $A_V = -1$)

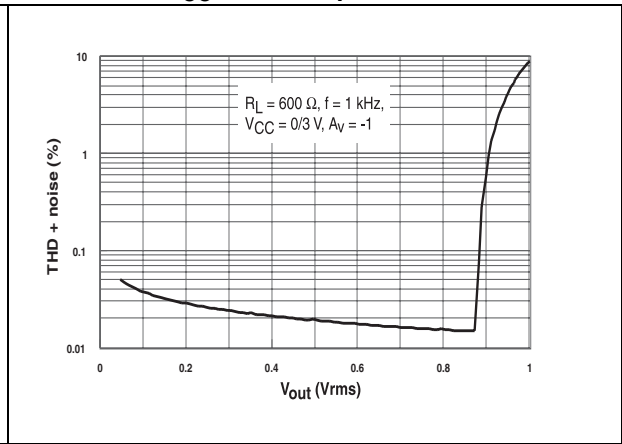

Figure 9. THD + noise vs. frequency
 ($R_L = 32 \Omega$, $V_O = 2 \text{ Vpp}$,
 $V_{CC} = \pm 1.5 \text{ V}$, $A_V = 10$)

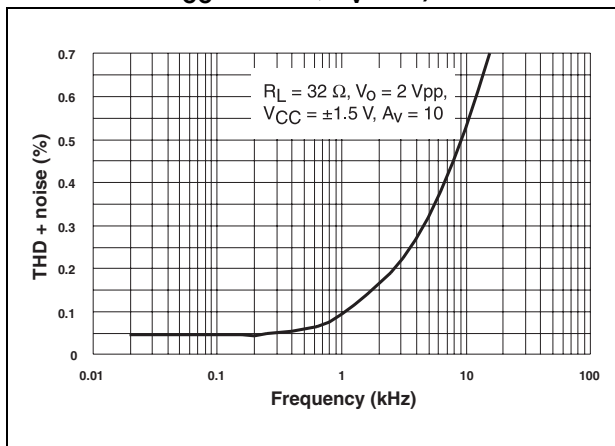

Figure 10. THD + noise vs. output voltage
 ($R_L = 32 \Omega$, $f = 1 \text{ kHz}$,
 $V_{CC} = \pm 1.5 \text{ V}$, $A_V = -1$)

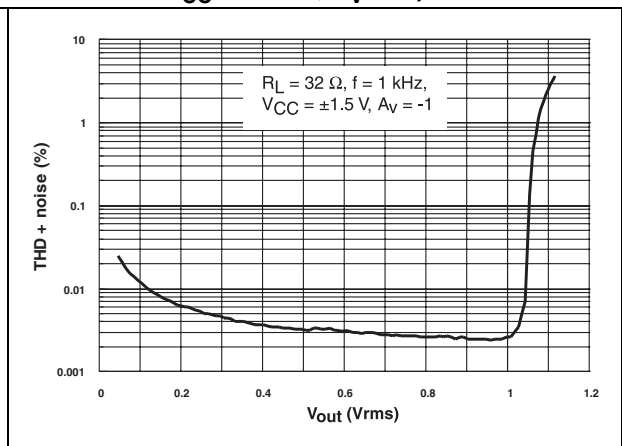

Figure 11. THD + noise vs. output voltage
 ($R_L = 2 \text{ k}\Omega$, $f = 1 \text{ kHz}$,
 $V_{CC} = \pm 1.5 \text{ V}$, $A_V = -1$)

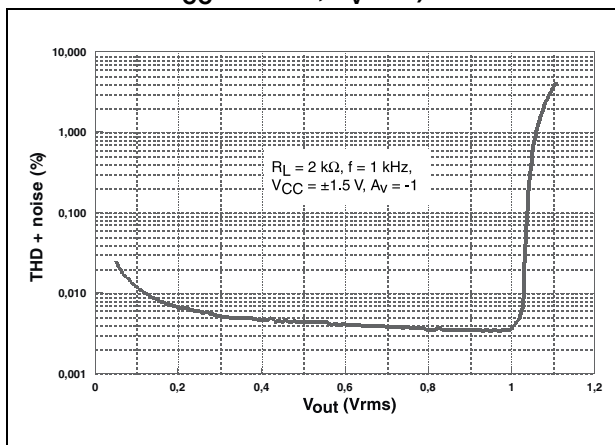
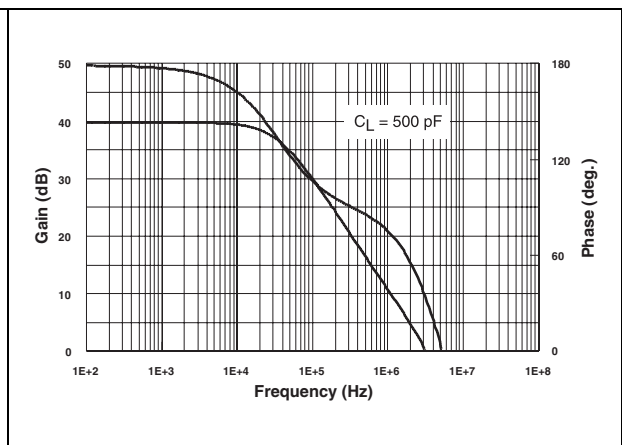

Figure 12. Open loop gain and phase vs. frequency
 ($C_L = 500 \text{ pF}$)



4 Macromodel

4.1 Important note concerning this macromodel

Please consider following remarks before using this macromodel:

- All models are a trade-off between accuracy and complexity (i.e. simulation time).
- Macromodels are not a substitute to breadboarding; rather, they confirm the validity of a design approach and help to select surrounding component values.
- A macromodel emulates the NOMINAL performance of a TYPICAL device within SPECIFIED OPERATING CONDITIONS (i.e. temperature, supply voltage, etc.). Thus the macromodel is often not as exhaustive as the datasheet, its goal is to illustrate the main parameters of the product.
- Data issued from macromodels used outside of its specified conditions (V_{CC} , temperature, etc.) or even worse: outside of the device operating conditions (V_{CC} , V_{icm} , etc.) are not reliable in any way.

In [Section 4.3](#), the electrical characteristics resulting from the use of these macromodels are presented.

4.2 Electrical characteristics from macromodelization

Table 6. Electrical characteristics resulting from macromodel simulation at $V_{CC} = 3\text{ V}$, $V_{DD} = 0\text{ V}$, R_L , C_L connected to $V_{CC/2}$, $T_{amb} = 25\text{ °C}$ (unless otherwise specified)

Symbol	Conditions	Value	Unit
V_{io}		0	mV
A_{vd}	$R_L = 10\text{ k}\Omega$	200	V/mV
I_{CC}	No load, per operator	1.2	mA
V_{icm}		-0.2 to 3.2	V
V_{OH}	$R_L = 10\text{ k}\Omega$	2.95	V
V_{OL}	$R_L = 10\text{ k}\Omega$	25	mV
I_{sink}	$V_O = 3\text{ V}$	80	mA
I_{source}	$V_O = 0\text{ V}$	80	mA
GBP	$R_L = 600\text{ k}\Omega$	4	MHz
SR	$R_L = 10\text{ k}\Omega$, $C_L = 100\text{ pF}$	1.3	V/ μ s
ϕ_m	$R_L = 600\text{ k}\Omega$	68	Degrees

4.3 Macromodel code

```

** Standard Linear Ics Macromodels, 1996.
** CONNECTIONS:
* 1 INVERTING INPUT
* 2 NON-INVERTING INPUT
* 3 OUTPUT
* 4 POSITIVE POWER SUPPLY
* 5 NEGATIVE POWER SUPPLY
.SUBCKT TS921 1 3 2 4 5 (analog)
*****.MODEL MDTH D
IS=1E-8 KF=2.664234E-16 CJO=10F
* INPUT STAGE
CIP 2 5 1.000000E-12
CIN 1 5 1.000000E-12
EIP 10 5 2 5 1
EIN 16 5 1 5 1
RIP 10 11 8.125000E+00
RIN 15 16 8.125000E+00
RIS 11 15 2.238465E+02
DIP 11 12 MDTH 400E-12
DIN 15 14 MDTH 400E-12
VOFP 12 13 DC 153.5u
VOFN 13 14 DC 0
IPOL 13 5 3.200000E-05
CPS 11 15 1e-9
DINN 17 13 MDTH 400E-12
VIN 17 5 -0.100000e+00
DINR 15 18 MDTH 400E-12
VIP 4 18 0.400000E+00
FCP 4 5 VOFP 1.865000E+02
FCN 5 4 VOFN 1.865000E+02
FIBP 2 5 VOFP 6.250000E-03
FIBN 5 1 VOFN 6.250000E-03
* GM1 STAGE *****
FGM1P 119 5 VOFP 1.1
FGM1N 119 5 VOFN 1.1
RAP 119 4 2.6E+06
RAN 119 5 2.6E+06
* GM2 STAGE *****
G2P 19 5 119 5 1.92E-02
G2N 19 5 119 4 1.92E-02
R2P 19 4 1E+07
R2N 19 5 1E+07
*****
VINT1 500 0 5

```

```

GCONVP 500 501 119 4 19.38!send ds VP, I(VP)=(V119-V4)/2/Ut VP 501 0 0
GCONVN 500 502 119 5 19.38!send ds VN, I(VN)=(V119-V5)/2/Ut VN 502 0 0
***** orientation isink isource *****
VINT2 503 0 5
FCOPY 503 504 VOUT 1
DCOPYP 504 505 MDTH 400E-9
VCOPYP 505 0 0
DCOPYN 506 504 MDTH 400E-9
VCOPYN 0 506 0
*****
F2PP 19 5 poly(2) VCOPYP VP 0 0 0 0 0.5!multiply I(vout)*I(VP)=Iout*(V119-
V4)/2/Ut
F2PN 19 5 poly(2) VCOPYP VN 0 0 0 0 0.5 !multiply I(vout)*I(VN)=Iout*(V119-
V5)/2/Ut
F2NP 19 5 poly(2) VCOPYN VP 0 0 0 0 1.75 !multiply I(vout)*I(VP)=Iout*(V119-
V4)/2/Ut
F2NN 19 5 poly(2) VCOPYN VN 0 0 0 0 1.75 !multiply I(vout)*I(VN)=Iout*(V119-
V5)/2/Ut
* COMPENSATION *****
CC 19 119 25p
* OUTPUT*****
DOPM 19 22 MDTH 400E-12
DONM 21 19 MDTH 400E-12
HOPM 22 28 VOUT 6.250000E+02
VIPM 28 4 5.000000E+01
HONM 21 27 VOUT 6.250000E+02
VINM 5 27 5.000000E+01
VOUT 3 23 0
ROUT 23 19 6
COUT 3 5 1.300000E-10
DOP 19 25 MDTH 400E-12
VOP 4 25 1.052
DON 24 19 MDTH 400E-12
VON 24 5 1.052
.ENDS

```

5 Package information

In order to meet environmental requirements, ST offers these devices in different grades of ECOPACK® packages, depending on their level of environmental compliance. ECOPACK specifications, grade definitions and product status are available at: www.st.com. ECOPACK is an ST trademark.

Figure 13. DIP8 package outline

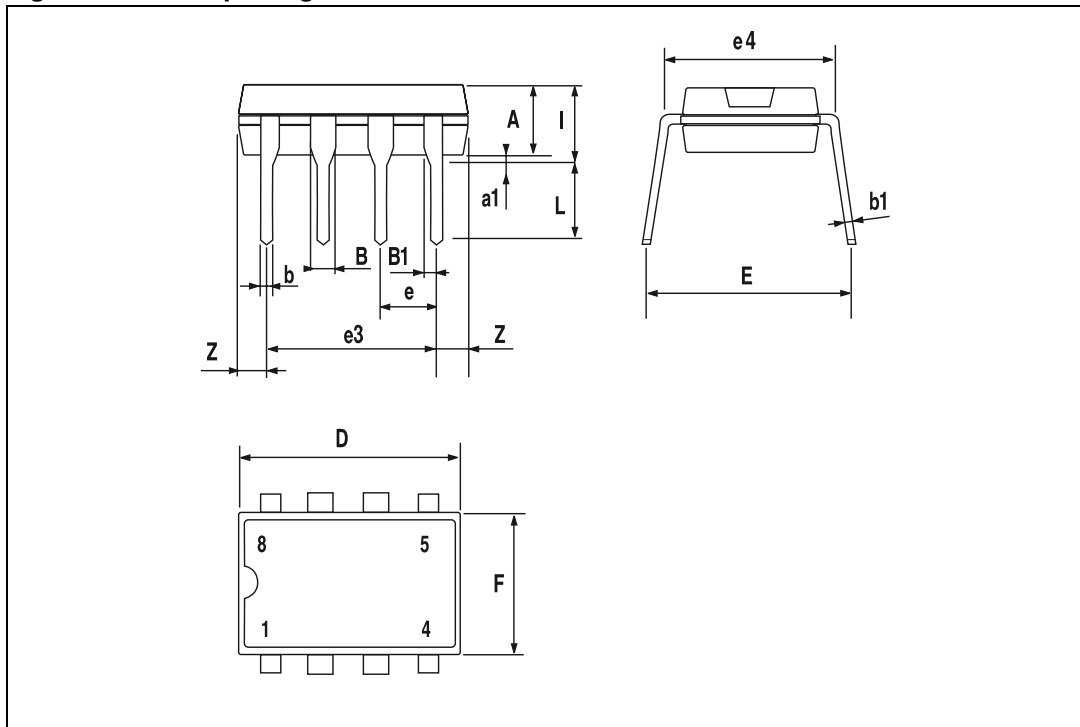
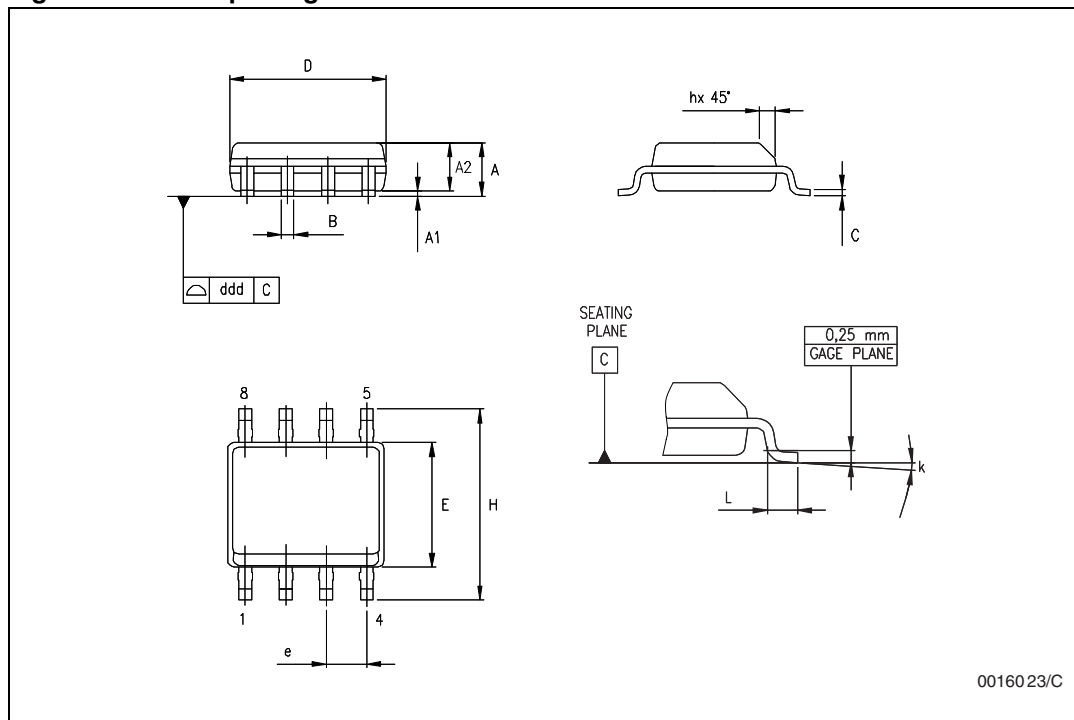

Table 7. DIP8 package mechanical data

Symbol	Dimensions					
	mm			inch		
	Min.	Typ.	Max.	Min.	Typ.	Max.
A		3.3			0.130	
a1	0.7			0.028		
B	1.39		1.65	0.055		0.065
B1	0.91		1.04	0.036		0.041
b		0.5			0.020	
b1	0.38		0.5	0.015		0.020
D			9.8			0.386
E		8.8			0.346	
e		2.54			0.100	
e3		7.62			0.300	
e4		7.62			0.300	
F			7.1			0.280
I			4.8			0.189
L		3.3			0.130	
Z	0.44		1.6	0.017		0.063

Figure 14. SO-8 package outline



0016023/C

Table 8. SO-8 package mechanical data

Symbol	Dimensions					
	mm			inch		
	Min.	Typ.	Max.	Min.	Typ.	Max.
A	1.35		1.75	0.053		0.069
A1	0.10		0.25	0.04		0.010
A2	1.10		1.65	0.043		0.065
B	0.33		0.51	0.013		0.020
C	0.19		0.25	0.007		0.010
D	4.80		5.00	0.189		0.197
E	3.80		4.00	0.150		0.157
e		1.27			0.050	
H	5.80		6.20	0.228		0.244
h	0.25		0.50	0.010		0.020
L	0.40		1.27	0.016		0.050
k	8° (max.)					
ddd			0.1			0.04

Figure 15. TSSOP8 package outline

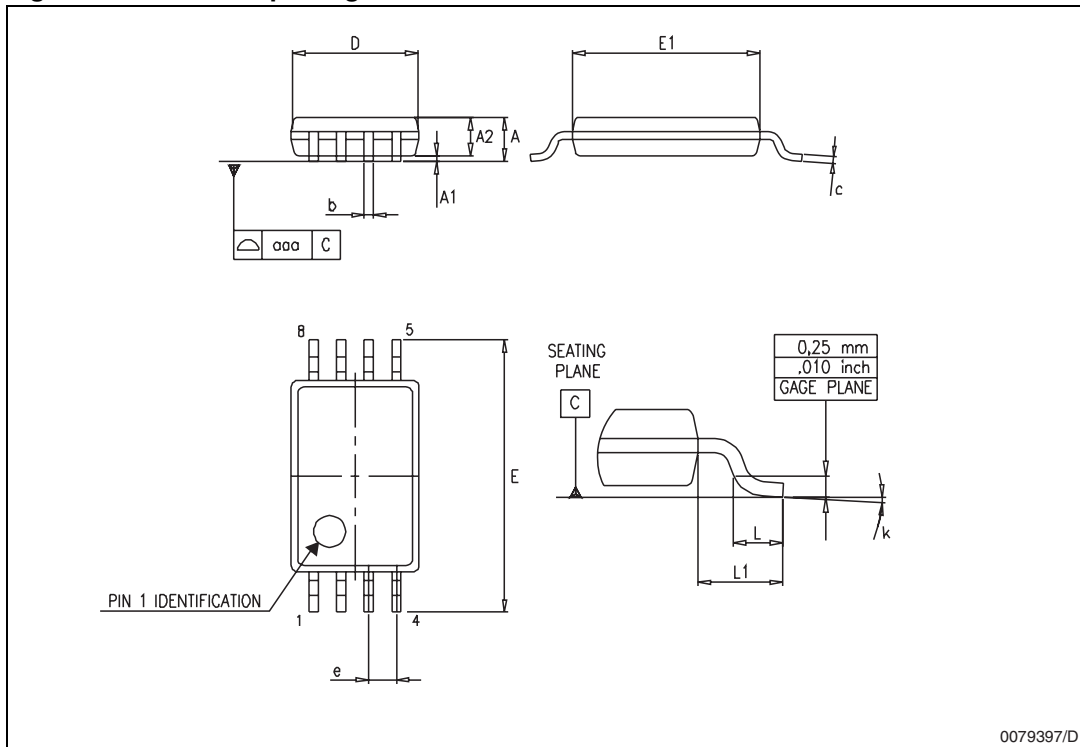

0079397/D

Table 9. TSSOP8 package mechanical data

Symbol	Dimensions					
	mm			inch		
	Min.	Typ.	Max.	Min.	Typ.	Max.
A			1.2			0.047
A1	0.05		0.15	0.002		0.006
A2	0.80	1.00	1.05	0.031	0.039	0.041
b	0.19		0.30	0.007		0.012
c	0.09		0.20	0.004		0.008
D	2.90	3.00	3.10	0.114	0.118	0.122
E	6.20	6.40	6.60	0.244	0.252	0.260
E1	4.30	4.40	4.50	0.169	0.173	0.177
e		0.65			0.0256	
K	0°		8°	0°		8°
L	0.45	0.60	0.75	0.018	0.024	0.030
L1		1			0.039	

6 Revision history

Table 10. Document revision history

Date	Revision	Changes
Feb. 2001	1	Initial release - Product in full production.
Dec. 2004	2	Modifications on AMR table page 2 (explanation of V_{id} and V_i limits, ESD, MM and CDM values added, Rthja added)
Nov. 2005	3	The following changes were made in this revision: PPAP references inserted in the datasheet see Table 1 . Data in tables Electrical characteristics on page 4 reformatted for easier use. Thermal Resistance Junction to Case added in Table 2 on page 3 .
19-Sep-2012	4	Updated Figure on page 1(replaced V_{CC-} by V_{DD}). Updated (renamed) Table 1 , removed TS921YD/IYDT devices from Table 1 . Moved Description to page 2. Updated Figure 1 to Figure 4 , Figure 6 to Figure 12 (added conditions to titles). Updated ECOPACK text and reformatted Section 5 (added Table 7 to Table 9 , reversed order of figures and tables). Minor corrections throughout document.

Please Read Carefully:

Information in this document is provided solely in connection with ST products. STMicroelectronics NV and its subsidiaries ("ST") reserve the right to make changes, corrections, modifications or improvements, to this document, and the products and services described herein at any time, without notice.

All ST products are sold pursuant to ST's terms and conditions of sale.

Purchasers are solely responsible for the choice, selection and use of the ST products and services described herein, and ST assumes no liability whatsoever relating to the choice, selection or use of the ST products and services described herein.

No license, express or implied, by estoppel or otherwise, to any intellectual property rights is granted under this document. If any part of this document refers to any third party products or services it shall not be deemed a license grant by ST for the use of such third party products or services, or any intellectual property contained therein or considered as a warranty covering the use in any manner whatsoever of such third party products or services or any intellectual property contained therein.

UNLESS OTHERWISE SET FORTH IN ST'S TERMS AND CONDITIONS OF SALE ST DISCLAIMS ANY EXPRESS OR IMPLIED WARRANTY WITH RESPECT TO THE USE AND/OR SALE OF ST PRODUCTS INCLUDING WITHOUT LIMITATION IMPLIED WARRANTIES OF MERCHANTABILITY, FITNESS FOR A PARTICULAR PURPOSE (AND THEIR EQUIVALENTS UNDER THE LAWS OF ANY JURISDICTION), OR INFRINGEMENT OF ANY PATENT, COPYRIGHT OR OTHER INTELLECTUAL PROPERTY RIGHT.

UNLESS EXPRESSLY APPROVED IN WRITING BY TWO AUTHORIZED ST REPRESENTATIVES, ST PRODUCTS ARE NOT RECOMMENDED, AUTHORIZED OR WARRANTED FOR USE IN MILITARY, AIR CRAFT, SPACE, LIFE SAVING, OR LIFE SUSTAINING APPLICATIONS, NOR IN PRODUCTS OR SYSTEMS WHERE FAILURE OR MALFUNCTION MAY RESULT IN PERSONAL INJURY, DEATH, OR SEVERE PROPERTY OR ENVIRONMENTAL DAMAGE. ST PRODUCTS WHICH ARE NOT SPECIFIED AS "AUTOMOTIVE GRADE" MAY ONLY BE USED IN AUTOMOTIVE APPLICATIONS AT USER'S OWN RISK.

Resale of ST products with provisions different from the statements and/or technical features set forth in this document shall immediately void any warranty granted by ST for the ST product or service described herein and shall not create or extend in any manner whatsoever, any liability of ST.

ST and the ST logo are trademarks or registered trademarks of ST in various countries.

Information in this document supersedes and replaces all information previously supplied.

The ST logo is a registered trademark of STMicroelectronics. All other names are the property of their respective owners.

© 2012 STMicroelectronics - All rights reserved

STMicroelectronics group of companies

Australia - Belgium - Brazil - Canada - China - Czech Republic - Finland - France - Germany - Hong Kong - India - Israel - Italy - Japan - Malaysia - Malta - Morocco - Philippines - Singapore - Spain - Sweden - Switzerland - United Kingdom - United States of America

www.st.com