



MC3303 MC3403 - MC3503

LOW POWER QUAD BIPOLAR OPERATIONAL AMPLIFIERS

- SHORT-CIRCUIT PROTECTED OUTPUTS
- CLASS AB OUTPUT STAGE FOR MINIMAL CROSSOVER DISTORTION
- SINGLE SUPPLY OPERATION: +3V TO +36V
- DUAL SUPPLIES: ±15V TO ±18V
- LOW INPUT BIAS CURRENT: 500nA MAX
- INTERNALLY COMPENSATED
- SIMILAR PERFORMANCE TO POPULAR UA741

DESCRIPTION

The MC3403 is a low-cost, quad operational amplifier with true differential inputs. The device has electrical characteristics similar to the popular UA741. However the MC3403, has several distinct advantages over standard operational amplifiers types in single supply applications. The quad amplifier can operate at supply voltage as low as 3 Volts or as high as 36 volts with quiescent currents about one third of those associated with the UA741 (on a per amplifier basis). The common-mode input range includes the negative supply, thereby eliminating the necessity for external biasing components in many applications.

ORDER CODE

Part Number	Temperature Range	Package		
		N	D	P
MC3303	-40°C, +105°C	•	•	•
MC3403	0°C, +70°C	•	•	•
MC3503	-55°C, +125°C	•	•	•

Example : MC3403N

N = Dual in Line Package (DIP)
D = Small Outline Package (SO) - also available in Tape & Reel (DT)
P = Thin Shrink Small Outline Package (TSSOP) - only available in Tape & Reel (PT)

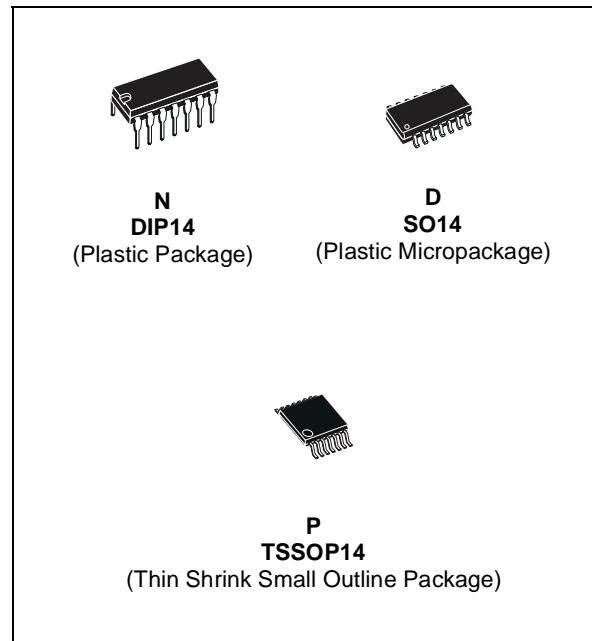

PIN CONNECTIONS (top view)

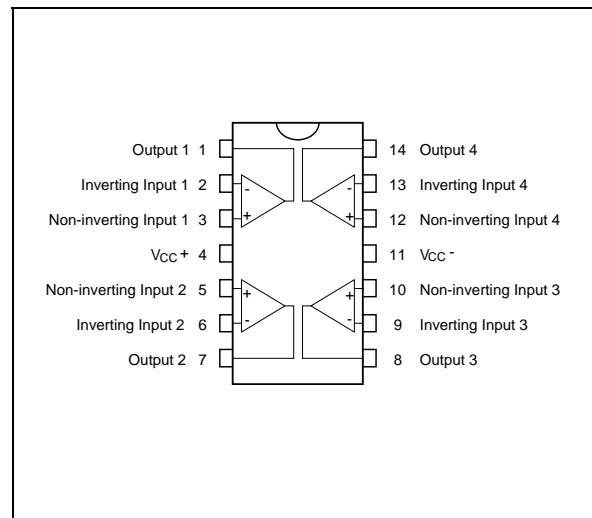

SCHEMATIC DIAGRAM (each amplifier)

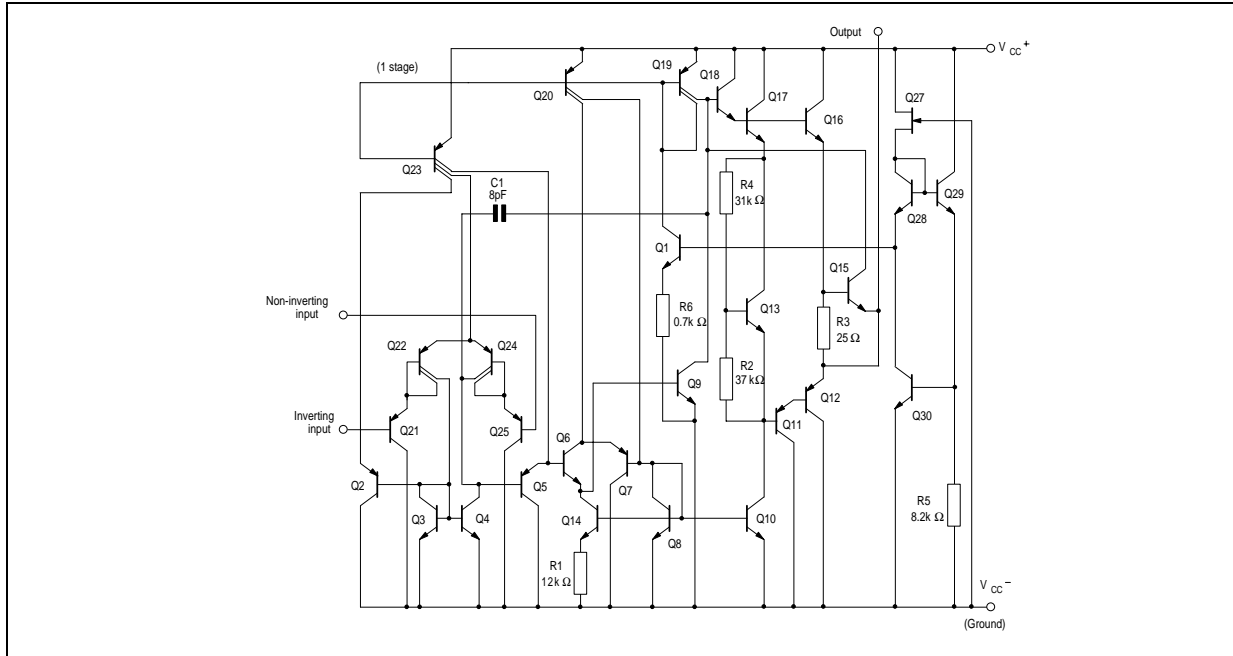

SCHEMATIC DIAGRAM

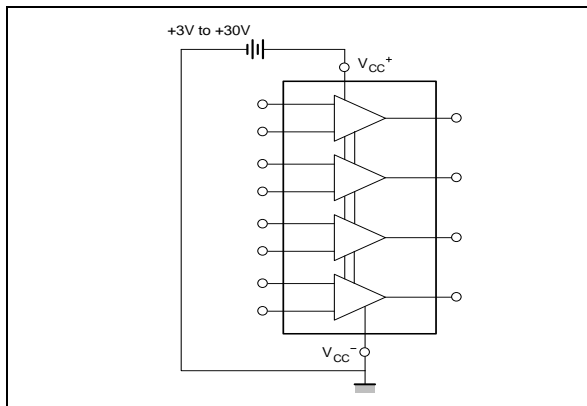

DUAL SUPPLIES

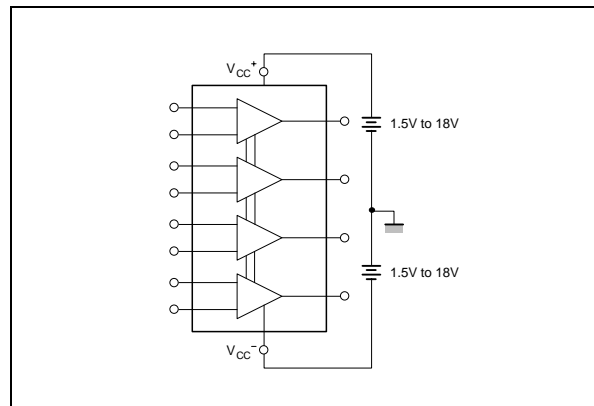

ABSOLUTE MAXIMUM RATINGS

Symbol	Parameter	MC3503	MC3403	MC3303	Unit
V_{CC}	Supply voltage	±18 or 36			V
V_i	Input Voltage ¹⁾	±18			V
V_{id}	Differential Input Voltage	±36			V
	Output Short-circuit Duration ²⁾	Infinite			
P_{tot}	Power Dissipation	500			mW
T_{oper}	Operating Free-air Temperature Range	-55 to +125	0 to +70	-40 to +105	°C
T_{stg}	Storage Temperature Range	-65 to +150			°C

- For supply voltage less than ±15V, the absolute maximum input voltage is equal to the supply voltage.
- Any of the amplifier outputs can be shorted to ground indefinitely; however more than one should not be simultaneously shorted as the maximum junction will be exceeded.

ELECTRICAL CHARACTERISTICS $V_{CC} = \pm 15V$, $T_{amb} = 25^{\circ}C$ (unless otherwise specified)

Symbol	Parameter	Min.	Typ.	Max.	Unit
V_{io}	Input Offset Voltage ($R_s \leq 10k\Omega$) $T_{amb} = 25^{\circ}C$ $T_{min} \leq T_{amb} \leq T_{max}$		1	5 6	mV
I_{io}	Input Offset Current $T_{amb} = 25^{\circ}C$ $T_{min} \leq T_{amb} \leq T_{max}$		5	50 200	nA
I_{ib}	Input Bias Current $T_{amb} = 25^{\circ}C$ $T_{min} \leq T_{amb} \leq T_{max}$		40	500 800	nA
A_{vd}	Large Signal Voltage Gain ($V_o = \pm 10V$, $R_L = 2k\Omega$) $T_{amb} = 25^{\circ}C$ $T_{min} \leq T_{amb} \leq T_{max}$	50 25	200		V/mV
SVR	Supply Voltage Rejection Ratio ($R_s \leq 10k\Omega$) $T_{amb} = 25^{\circ}C$ $T_{min} \leq T_{amb} \leq T_{max}$	77 77	90		dB
I_{cc}	Supply Current, all Amp, no load $T_{amb} = 25^{\circ}C$ $T_{min} \leq T_{amb} \leq T_{max}$		2.8	7 4 8 5	mA
	MC3503				
	MC3503				
V_{icm}	Input Common Mode Voltage Range $T_{amb} = 25^{\circ}C$ $T_{min} \leq T_{amb} \leq T_{max}$	-15 -15		+13 +13	V
CMR	Common Mode Rejection Ratio ($R_s \leq 10k\Omega$) $T_{amb} = 25^{\circ}C$ $T_{min} \leq T_{amb} \leq T_{max}$	70 70	90		dB
I_{os}	Output Short-circuit Current	10	30	45	mA
$\pm V_{opp}$	Output Voltage Swing $T_{amb} = 25^{\circ}C$ $T_{min} \leq T_{amb} \leq T_{max}$				
	$R_L \leq 10k\Omega$	12	13.5		V
	$R_L \leq 2k\Omega$	10	13		
	$R_L \leq 10k\Omega$	12			
	$R_L \leq 2k\Omega$	10			
SR	Slew Rate ($V_i = \pm 10V$, $R_L = 2k\Omega$, $C_L = 100pF$, $T_{amb} = 25^{\circ}C$, unity gain)	0.35	0.5		V/ μs
t_r, t_f	Rsie Time ($V_o = \pm 20mV$, $R_L = 2k\Omega$, $C_L = 100pF$, $T_{amb} = 25^{\circ}C$, unity gain)		0.18		μs
K_{OV}	Overshoot ($V_i = \pm 20mV$, $R_L = 2k\Omega$, $C_L = 100pF$, $T_{amb} = 25^{\circ}C$, unity gain)		10		%
Z_i	Input Impedance	0.3	1		M Ω
Z_o	Output Impedance		75		Ω
B_{om}	Power Bandwidth ($R_L = 2k\Omega$, $C_L = 100pF$, $A_v = 1$, $T_{amb} = 25^{\circ}C$, $V_o = 2V_{pp}$, THD $\leq 5\%$)		9		kHz
B	Unity Gain Bandwidth $V_o = 10mV$, $R_L = 2k\Omega$, $C_L = 100pF$, $T_{amb} = 25^{\circ}C$, unity gain)		1		MHz

Symbol	Parameter	Min.	Typ.	Max.	Unit
GBP	Gain Bandwidth Product ($V_O = 10 \text{ mV}$, $R_L = 2\text{k}\Omega$, $C_L = 100\text{pF}$ $f = 100\text{kHz}$, $T_{\text{amb}} = 25^\circ\text{C}$)	0.7	1		MHz
THD	Total Harmonic Distortion ($f = 1\text{kHz}$, $A_V = 20\text{dB}$, $R_L = 2\text{k}\Omega$ $C_L = 100\text{pF}$, $V_O = 2V_{\text{pp}}$, $T_{\text{amb}} = 25^\circ\text{C}$)		0.02		%
e_n	Equivalent Input Noise Voltage ($f = 1\text{kHz}$, $R_S = 100\Omega$)		43		$\frac{\text{nV}}{\sqrt{\text{Hz}}}$
ϕ_m	Phase Margin		60		Degrees
DV_{io}	Input Offset Voltage Drift $T_{\text{min}} \leq T_{\text{amb}} \leq T_{\text{max}}$		10		$\mu\text{V}/^\circ\text{C}$
DI_{io}	Input Offset Current Drift $T_{\text{min}} \leq T_{\text{amb}} \leq T_{\text{max}}$		50		$\text{pA}/^\circ\text{C}$
V_{O1}/V_{O2}	Channel Separation		120		dB

ELECTRICAL CHARACTERISTICS

$V_{CC^+} = 5\text{V}$, $V_{CC^-} = \text{Ground}$, $T_{\text{amb}} = 25^\circ\text{C}$ (unless otherwise specified)

Symbol	Parameter	Min.	Typ.	Max.	Unit
V_{io}	Input Offset Voltage ($R_S \leq 10\text{k}\Omega$) $T_{\text{amb}} = 25^\circ\text{C}$ $T_{\text{min}} \leq T_{\text{amb}} \leq T_{\text{max}}$		1	5 6	mV
I_{io}	Input Offset Current $T_{\text{amb}} = 25^\circ\text{C}$ $T_{\text{min}} \leq T_{\text{amb}} \leq T_{\text{max}}$		5	50 200	nA
I_{ib}	Input Bias Current $T_{\text{amb}} = 25^\circ\text{C}$ $T_{\text{min}} \leq T_{\text{amb}} \leq T_{\text{max}}$		40	500 800	nA
A_{vd}	Large Signal Voltage Gain ($V_O = 1.4\text{V}$ to 2.4V , $R_L = 2\text{k}\Omega$) $T_{\text{amb}} = 25^\circ\text{C}$ $T_{\text{min}} \leq T_{\text{amb}} \leq T_{\text{max}}$	10 5	200		V/mV
SVR	Supply Voltage Rejection Ratio ($R_S \leq 10\text{k}\Omega$) $T_{\text{amb}} = 25^\circ\text{C}$ $T_{\text{min}} \leq T_{\text{amb}} \leq T_{\text{max}}$	77 77	90		dB
I_{CC}	Supply Current, all Amp, no load MC3503		2.8	7 4	mA
V_{opp}	Output Voltage Range ($R_L = 10\text{k}\Omega$) $V_{CC} = +5\text{V}$ $+5 < V_{CC} \leq +30\text{V}$	3.3 $V_{CC^+} - 2\text{V}$	3.5 $V_{CC^+} - 1.7\text{V}$		V

CIRCUIT DESCRIPTION

The MC3403 is made using four internally compensated, two-stage operational amplifiers. The first stage of each consists of differential input devices Q24 and Q22 with input buffer transistors Q25 and Q21 and the differential to single ended converter Q3 and Q4. The first stage performs not only the first stage gain function but also performs the level shifting and transconductance reduction functions. By reducing the transconductance a smaller compensation capacitor (only 8pF) can be employed, thus saving chip area.

The transconductance reduction is accomplished by splitting the collectors of Q24 and Q22. Another feature of this input stage is that the input common-mode range can include the negative supply fo ground, in single supply operation, without saturation either the input devices or the differential to single-ended converter.

The second stage consists of a standard current source load amplifier stage. The output stage is unique because it allows the output to swing to ground in single supply operation and yet does not exhibit any crossover distortion in split supply operations. This is possible because class AB operation is utilized.

Each amplifier is biased from an internal voltage regulator which has a low temperature coefficient thus giving each amplifier good temperature characteristics as well as excellent power supply rejection.

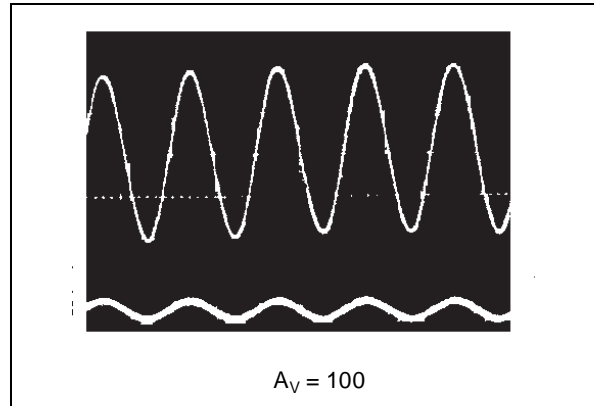

APPLICATION INFORMATION

VOLTAGE REFERENCE

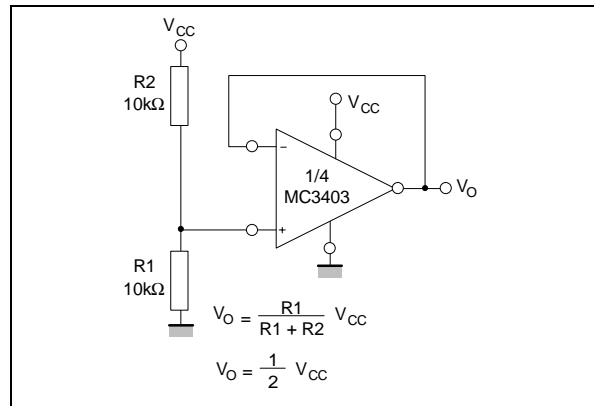

TYPICAL PERFORMANCE CURVES

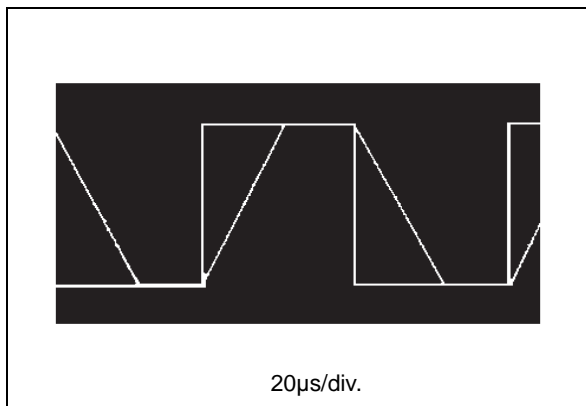

WIEN BRIDGE OSCILLATOR

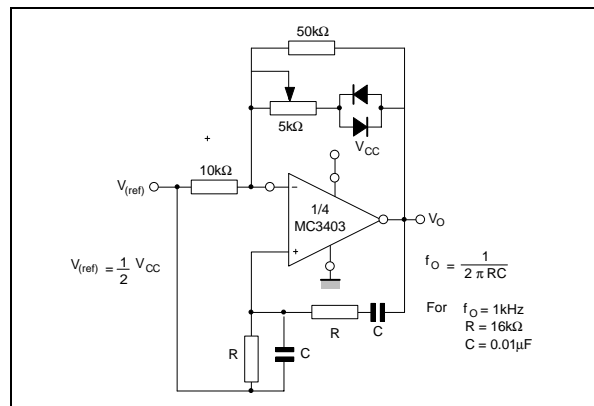

HIGH IMPEDANCE DIFFERENTIAL AMPLIFIER

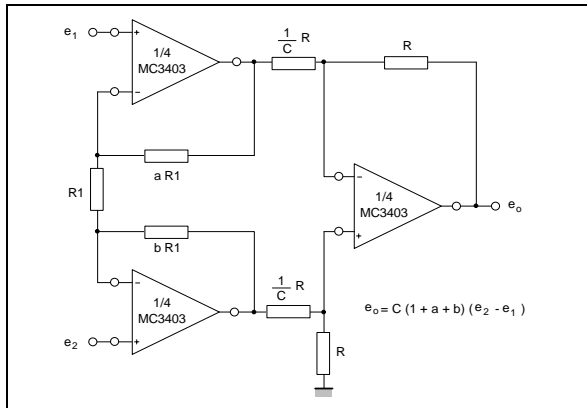

COMPARATOR WITH HYSTERESIS

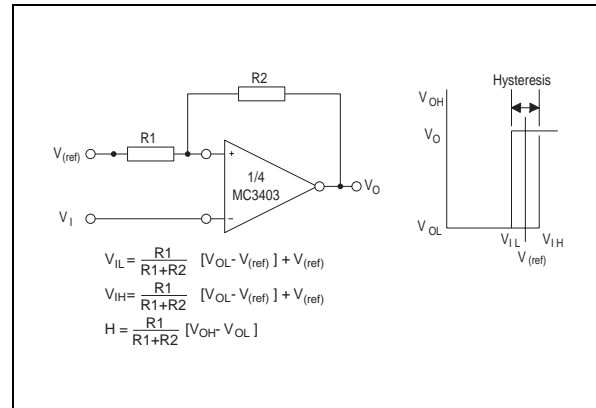

BI-QUAD FILTER

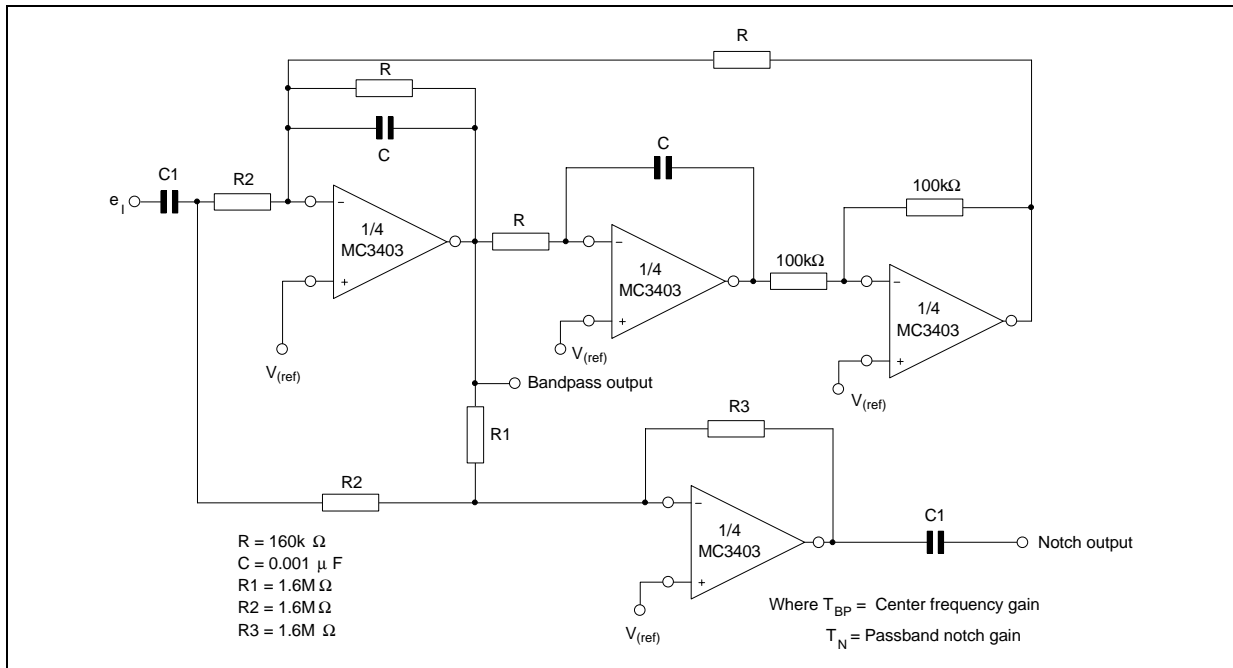

FUNCTION GENERATOR

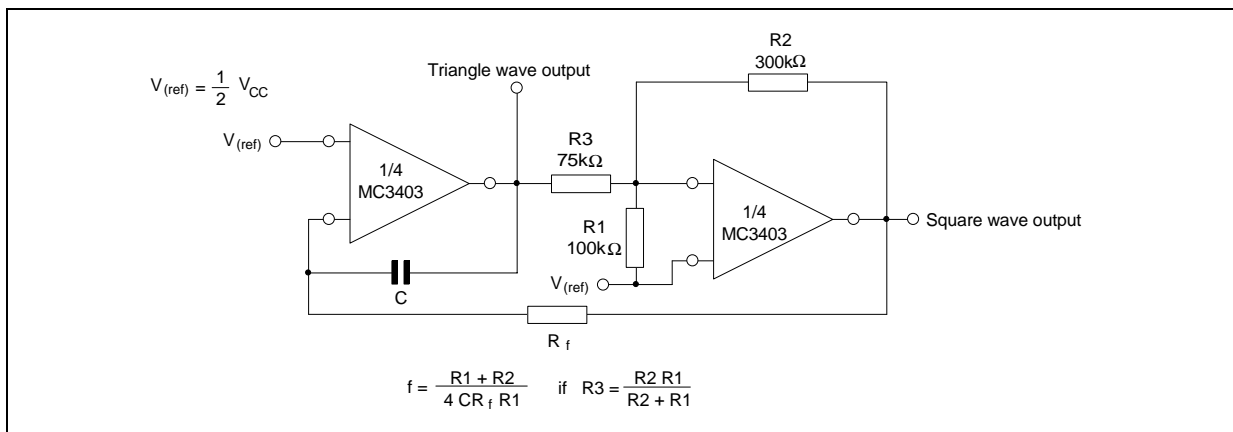

MULTIPLE FEEDBACK BANDPASS FILTER

Given f_o = center frequency ; chose values f_o , C than
 $A(f_o)$ = gain at center frequency

$$R3 = \frac{Q}{f_o C}$$

$$R1 = \frac{R3}{2A(f_o)}$$

$$R2 = \frac{R1 R5}{4Q^2 R1 - R5}$$

For less than 10% error from operational amplifier
 $\frac{Q_o F_o}{BW} < 0.1$ where f_o and BW are expressed in Hz
 If source impedance varies, filter may be preceded with voltage follower buffer to stabilize filter parameters

TYPICAL PERFORMANCE CURVES

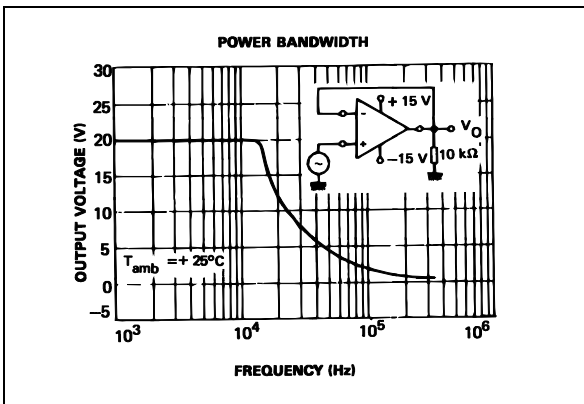
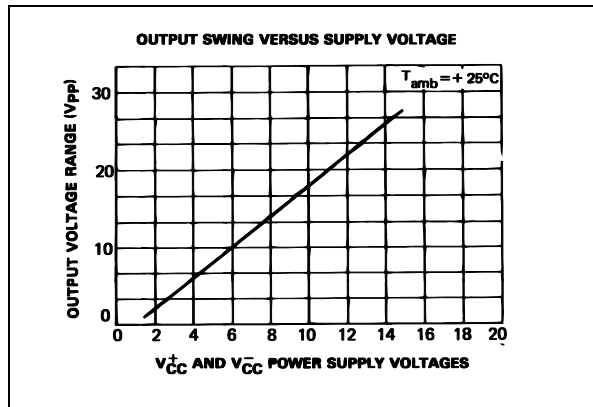
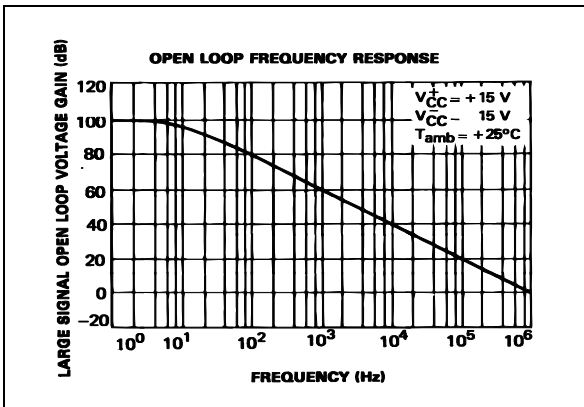

PACKAGE MECHANICAL DATA
14 PINS - PLASTIC PACKAGE

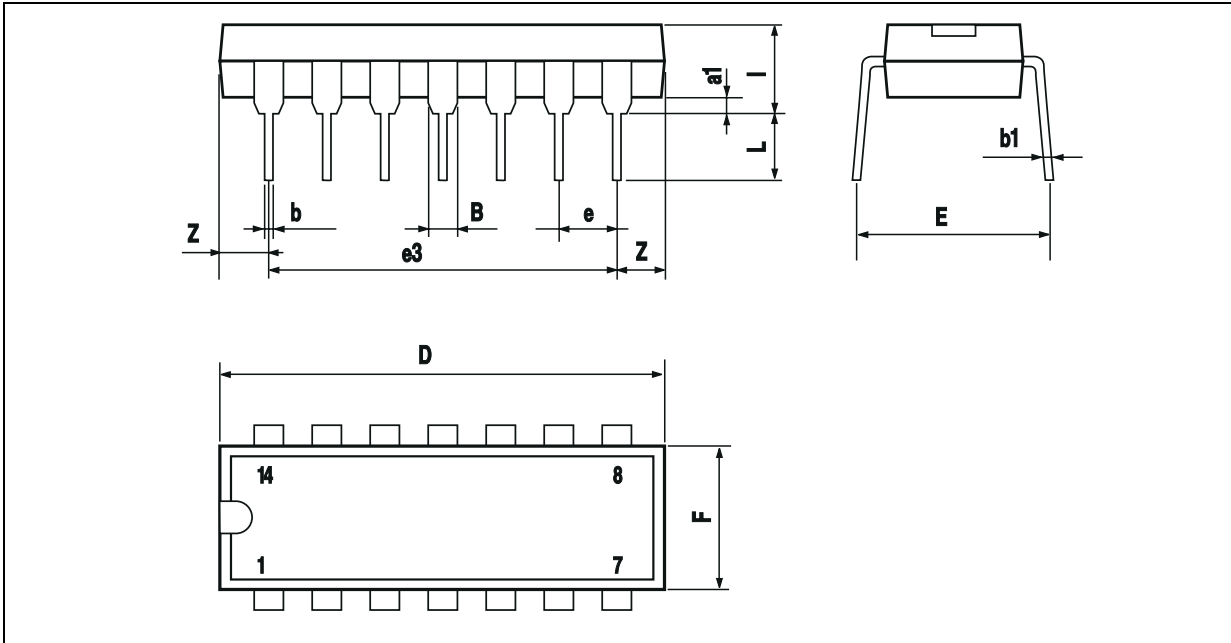

Dimensions	Millimeters			Inches		
	Min.	Typ.	Max.	Min.	Typ.	Max.
a_1	0.51			0.020		
B	1.39		1.65	0.055		0.065
b		0.5			0.020	
b_1		0.25			0.010	
D			20			0.787
E		8.5			0.335	
e		2.54			0.100	
e_3		15.24			0.600	
F			7.1			0.280
i			5.1			0.201
L		3.3			0.130	
Z	1.27		2.54	0.050		0.100

PACKAGE MECHANICAL DATA
 14 PINS - PLASTIC MICROPACKAGE (SO)

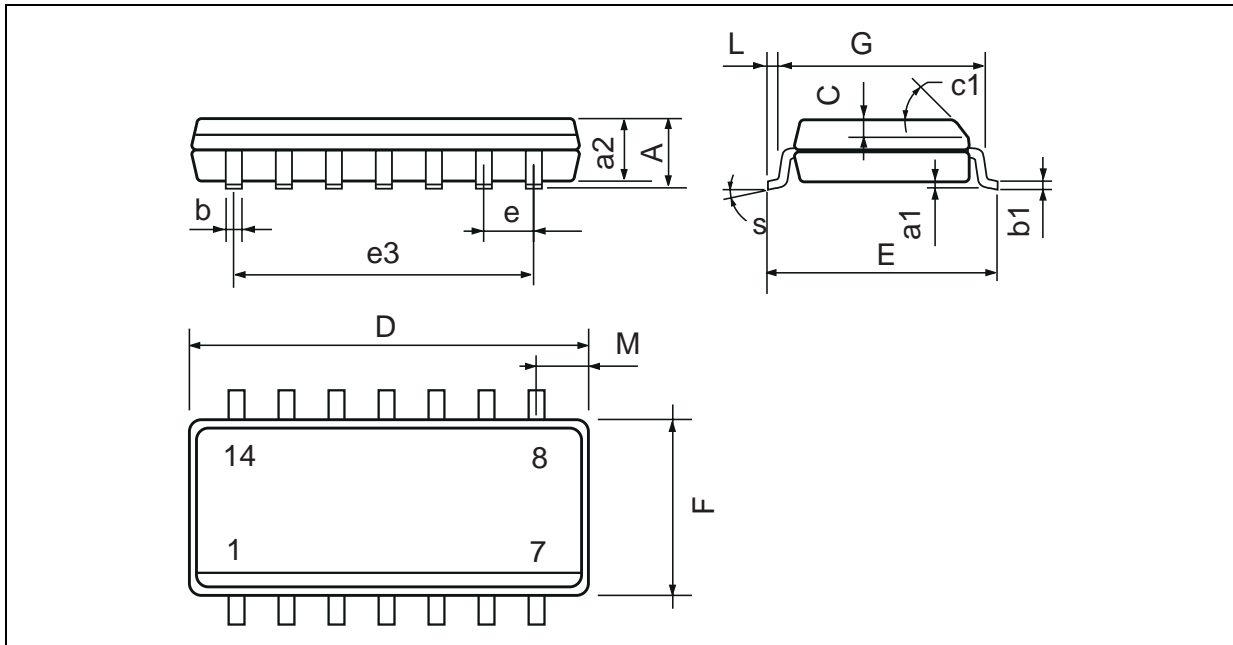

Dimensions	Millimeters			Inches		
	Min.	Typ.	Max.	Min.	Typ.	Max.
A			1.75			0.069
a1	0.1		0.2	0.004		0.008
a2			1.6			0.063
b	0.35		0.46	0.014		0.018
b1	0.19		0.25	0.007		0.010
C		0.5			0.020	
c1	45° (typ.)					
D (1)	8.55		8.75	0.336		0.344
E	5.8		6.2	0.228		0.244
e		1.27			0.050	
e3		7.62			0.300	
F (1)	3.8		4.0	0.150		0.157
G	4.6		5.3	0.181		0.208
L	0.5		1.27	0.020		0.050
M			0.68			0.027
S	8° (max.)					

Note : (1) D and F do not include mold flash or protrusions - Mold flash or protrusions shall not exceed 0.15mm (.066 inc) ONLY FOR DATA BOOK.

PACKAGE MECHANICAL DATA
 14 PINS - THIN SHRINK SMALL OUTLINE PACKAGE

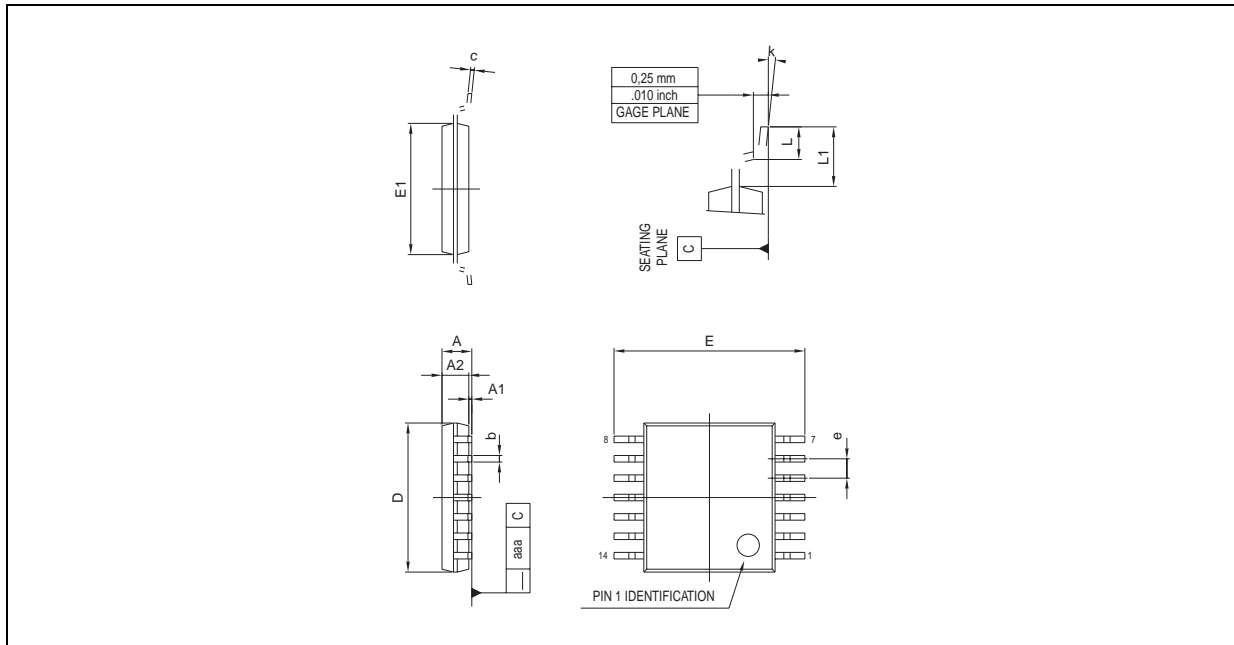

Dimensions	Millimeters			Inches		
	Min.	Typ.	Max.	Min.	Typ.	Max.
A			1.20			0.05
A1	0.05		0.15	0.01		0.006
A2	0.80	1.00	1.05	0.031	0.039	0.041
b	0.19		0.30	0.007		0.15
c	0.09		0.20	0.003		0.012
D	4.90	5.00	5.10	0.192	0.196	0.20
E		6.40			0.252	
E1	4.30	4.40	4.50	0.169	0.173	0.177
e		0.65			0.025	
k	0°		8°	0°		8°
L	0.450	0.600	0.750	0.018	0.024	0.030
L1		1.00			0.039	
aaa			0.100			0.004

Information furnished is believed to be accurate and reliable. However, STMicroelectronics assumes no responsibility for the consequences of use of such information nor for any infringement of patents or other rights of third parties which may result from its use. No license is granted by implication or otherwise under any patent or patent rights of STMicroelectronics. Specifications mentioned in this publication are subject to change without notice. This publication supersedes and replaces all information previously supplied. STMicroelectronics products are not authorized for use as critical components in life support devices or systems without express written approval of STMicroelectronics.

© The ST logo is a registered trademark of STMicroelectronics

© 2001 STMicroelectronics - Printed in Italy - All Rights Reserved
 STMicroelectronics GROUP OF COMPANIES

Australia - Brazil - Canada - China - Finland - France - Germany - Hong Kong - India - Israel - Italy - Japan - Malaysia
 Malta - Morocco - Singapore - Spain - Sweden - Switzerland - United Kingdom - United States

© <http://www.st.com>