

Rad-hard precision quad operational amplifier

Features

- High radiation immunity: 300 kRad TID at high dose rate
- ELDRS-free up to 100 krad
- 300 krad low dose rate on-going
- SEL immune at LET = 120 MeV.cm²/mg at 125°C
- SET characterized
- Hermetic package
- Rail-to-rail input/output
- 8 MHz gain bandwidth product
- Low input offset voltage: 60 μV typ
- Supply current: 2.2 mA typ per amplifier
- Operating from 4 to 14 V
- Input bias current: 6 nA typ
- QLM-V qualified under smd 5962-08222

Applications

- Space probes and satellites
- Harsh environment

Description

The RHF484 is a rail-to-rail precision bipolar quad operational amplifier featuring a low input offset voltage and a wide supply voltage.

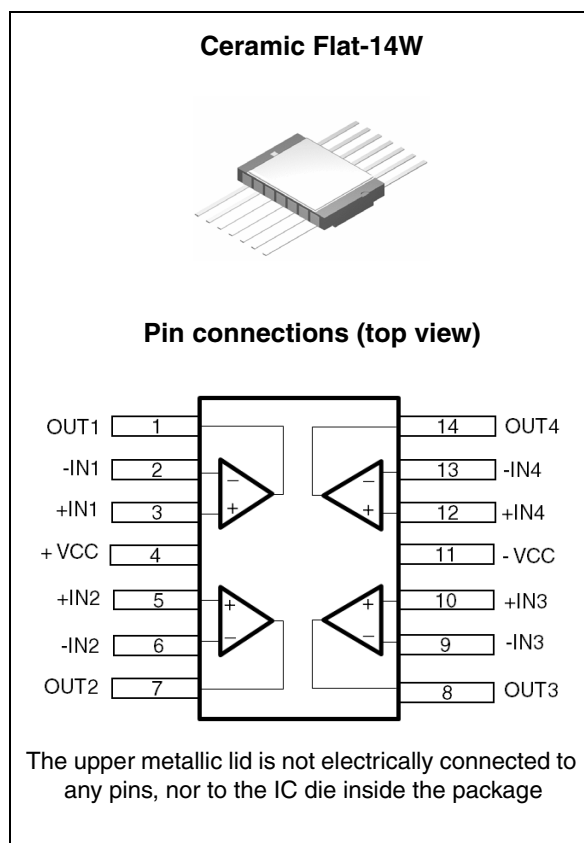

Designed to increase tolerance to radiation, the RHF484 is housed in a hermetic 14-pin flat package, making it an ideal product for space applications and harsh environments.

Table 1. Device summary

| Reference | SMD pin | Quality level | Temp range | Package | Lead finish | Mass | EPPL |
|-------------|------------|-------------------|-----------------|-----------|-------------|--------|------|
| RHF484K1 | | Engineering model | -55°C to +125°C | Flat-14 W | Gold | 0.70 g | - |
| RHF484K-01V | 5962F08222 | Flight model | | | | | - |

Note: Contact your ST sales office for information on specific conditions for products in die form.

1 Absolute maximum ratings and operating conditions

Table 2. Absolute maximum ratings

| Symbol | Parameter | Value | Unit |
|-------------------------------|--|---|-------------------------|
| V_{CC} | Supply voltage (+ V_{CC})-(- V_{CC}) | 18 | V |
| V_{id} | Differential input voltage ⁽¹⁾ | ±1.2 | V |
| V_{in} | Input voltage ⁽²⁾⁽³⁾ | - V_{CC} -0.3V to + V_{CC} +0.3V | V |
| I_{in} | Input current | 45 | mA |
| T_{stg} | Storage temperature range | -65 to +150 | °C |
| T_j | Maximum junction temperature | 150 | °C |
| R_{thja} | Thermal resistance junction to ambient ⁽⁴⁾ Flat package, 14 pins | TBD | °C/W |
| R_{thjc} | Thermal resistance junction to case ⁽⁴⁾ Flat package, 14 pins | TBD | °C/W |
| ESD | HBM: human body model ⁽⁵⁾ | 2 | kV |
| T_{Lead} | Lead temperature (soldering, 10 sec) | 260 | °C |
| Radiation informations | | | |
| Dose | Low dose rate of 0.01 rad.sec ⁻¹ | 100 | kRad |
| | High dose rate of 50-300 rad.sec ⁻¹ | 300 | kRad |
| Heavy ions | SEL immunity (at 125°C) | 120 | MeV.cm ² /mg |
| | SET characterized | | |

1. The differential voltage is the voltage difference between the pins +IN and -IN of a channel.
2. All voltage values, except differential voltage are with respect to network ground terminal.
3. The voltage on either input must never exceed + V_{CC} +0.3 V nor 16 V.
4. Short-circuits can cause excessive heating and destructive dissipation. Values are typical.
5. Human body model: a 100 pF capacitor is charged to the specified voltage, then discharged through a 1.5 kΩ resistor between two pins of the device. This is done for all couples of connected pin combinations while the other pins are floating.

Table 3. Operating conditions

| Symbol | Parameter | Value | Unit |
|-----------------------------|--------------------------------------|--------------------------|------|
| (+ V_{CC})-(- V_{CC}) | Supply voltage | 4 to 14 ⁽¹⁾ | V |
| V_{icm} | Common-mode input voltage range | - V_{CC} to + V_{CC} | V |
| T_{oper} | Operating free-air temperature range | -55 to +125 | °C |

1. SEL-free, up to 120 MeV.cm²/mg.

2 Electrical characteristics

Table 4. $+V_{CC} = 7\text{ V}$, $-V_{CC} = 7\text{ V}$, $V_{icm} = 0\text{ V}$, $T_{amb} = 25^\circ\text{C}$, loads (R_L, C_L) connected to GND (unless otherwise specified)

| Symbol | Parameter | Test conditions | Temp. | Min. | Typ. | Max. | Unit | | |
|-----------------------|--|--|--------|------|------|------|------------------------------|---------------|---------------|
| DC performance | | | | | | | | | |
| V_{io} | Offset voltage | $V_{icm} = +7\text{ V}$ | -55°C | | | 700 | μV | | |
| | | | +25°C | | | 500 | | | |
| | | | +125°C | | | 700 | | | |
| | | $V_{icm} = +0\text{ V}$ | -55°C | | | 500 | | μV | |
| | | | +25°C | | 60 | 300 | | | |
| | | | +125°C | | | 500 | | | |
| | | $V_{icm} = -7\text{ V}$ | -55°C | | | 700 | | | μV |
| | | | +25°C | | | 500 | | | |
| | | | +125°C | | | 700 | | | |
| DV_{io} | Input offset voltage drift | No load | | | 1 | | $\mu\text{V}/^\circ\text{C}$ | | |
| I_{ib} | Input bias current | No load | -55°C | | | 100 | nA | | |
| | | | +25°C | | 6 | 60 | | | |
| | | | +125°C | | | 100 | | | |
| DI_{ib} | Input offset current temp. drift | No load | | | 100 | | $\text{pA}/^\circ\text{C}$ | | |
| I_{io} | Input offset current | No load $V_{out} = 0\text{ V}$ | -55°C | | | 35 | nA | | |
| | | | +25°C | | 2 | 15 | | | |
| | | | +125°C | | | 35 | | | |
| C_{in} | Differential input capacitance between +IN and -IN | | +25°C | | 8 | | pF | | |
| | Input capacitance between +IN (or -IN) and GND | | +25°C | | 2 | | | | |
| I_{CC} | Supply current per amplifier | No load | -55°C | | | 2.9 | mA | | |
| | | | +25°C | | 2.2 | 2.9 | | | |
| | | | +125°C | | | 2.9 | | | |
| CMR | Common mode rejection ratio | No load $-V_{CC} < V_{icm} < +V_{CC}$ | -55°C | 72 | | | dB | | |
| | | | +25°C | 72 | 105 | | | | |
| | | | +125°C | 72 | | | | | |
| SVR | Supply rejection ratio | No load From $+V_{CC} = 2\text{ V}$ and $-V_{CC} = -2\text{ V}$ to $+V_{CC} = 7\text{ V}$ and $-V_{CC} = -7\text{ V}$ | -55°C | 80 | | | dB | | |
| | | | +25°C | 90 | 120 | | | | |
| | | | +125°C | 80 | | | | | |

Table 4. +V_{CC} = 7 V, -V_{CC} = 7 V, V_{icm} = 0 V, T_{amb} = 25°C, loads (R_L, C_L) connected to GND (unless otherwise specified) (continued)

| Symbol | Parameter | Test conditions | Temp. | Min. | Typ. | Max. | Unit | |
|-------------------------------|-----------------------------------|---|--------|------|------|------|------------------------|---|
| AC performance | | | | | | | | |
| GBP | Gain bandwidth product | V _{out} = 200 mVpp f = 100 kHz R _L = 1 kΩ C _L = 100 pF | -55°C | 3.5 | | | MHz | |
| | | | +25°C | 6 | 8 | | | |
| | | | +125°C | 3.5 | | | | |
| F _u | Unity gain frequency | R _L = 1 kΩ, C _L = 100 pF | +25°C | | 5 | | MHz | |
| ϕ _m | Phase margin | R _L = 1 kΩ, C _L = 100 pF G = +5 | +25°C | | 50 | | Degrees | |
| A _{VD} | Large signal voltage gain | R _L = 10 kΩ V _{out} = -6.5 V to 6 V | -55°C | 60 | | | dB | |
| | | | +25°C | 74 | 85 | | | |
| | | | +125°C | 60 | | | | |
| SR | Slew rate | R _L = 1 kΩ V _{out} = -4.8 V to 4.8 V V _{out} = 4.8 V to -4.8 V | -55°C | 1.7 | | | V/μs | |
| | | | +25°C | 2 | 3.5 | | | |
| | | | +125°C | 1.7 | | | | |
| e _n | Equivalent input noise voltage | No load, f = 1 kHz | +25°C | | 7 | | $\frac{nV}{\sqrt{Hz}}$ | |
| i _n | Equivalent input noise current | No load, f = 1 kHz | +25°C | | 0.8 | | $\frac{pA}{\sqrt{Hz}}$ | |
| THD+e _n | Total harmonic distortion + noise | V _{out} = 13 Vpp, R _L = 1 kΩ, C _L = 100 pF G = -5.1 | +25°C | | 0.01 | | % | |
| Output characteristics | | | | | | | | |
| V _{OH} | High level output voltage | +V _{CC} = 14 V, -V _{CC} = 0 V R _L = 1 kΩ | -55°C | 13.5 | | | V | |
| | | | +25°C | 13.6 | 13.8 | | | |
| | | | +125°C | 13.5 | | | | |
| | | +V _{CC} = 14 V, -V _{CC} = 0 V R _L = 10 kΩ | -55°C | 13.6 | | | V | |
| | | | +25°C | 13.8 | 13.9 | | | |
| | | | +125°C | 13.6 | | | | |
| V _{OL} | Low level output voltage | +V _{CC} = 14 V, -V _{CC} = 0 V R _L = 1 kΩ | -55°C | | | 0.3 | V | |
| | | | +25°C | | 0.12 | 0.2 | | |
| | | | +125°C | | | 0.3 | | |
| | | +V _{CC} = 14 V, -V _{CC} = 0 V R _L = 10 kΩ | -55°C | | | | 0.2 | V |
| | | | +25°C | | 0.04 | 0.08 | | |
| | | | +125°C | | | 0.2 | | |

Table 4. $+V_{CC} = 7\text{ V}$, $-V_{CC} = 7\text{ V}$, $V_{icm} = 0\text{ V}$, $T_{amb} = 25^{\circ}\text{C}$, loads (R_L, C_L) connected to GND
(unless otherwise specified) (continued)

| Symbol | Parameter | Test conditions | Temp. | Min. | Typ. | Max. | Unit |
|-----------------|-----------------------|--|--------|------|------|------|------|
| $I_{out}^{(1)}$ | Output sink current | $V_{out} = +V_{CC}$ No load, $V_{id} = -1\text{ V}$ | -55°C | 15 | | | mA |
| | | | +25°C | 20 | 35 | | |
| | | | +125°C | 15 | | | |
| | Output source current | $V_{out} = -V_{CC}$ No load, $V_{id} = +1\text{ V}$ | -55°C | 10 | | | mA |
| | | | +25°C | 15 | 30 | | |
| | | | +125°C | 10 | | | |

1. These tests are performed during a very short period of time. Excessive heating can damage the device. In the application, the junction temperature must never exceed 150°C as specified in [Table 2](#).

Table 5. +V_{CC} = +2 V, -V_{CC} = -2 V, V_{icm} = 0 V, T_{amb} = 25°C, loads (R_L, C_L) connected to GND (unless otherwise specified)

| Symbol | Parameter | Test conditions | Temp. | Min. | Typ. | Max. | Unit | | |
|-----------------------|--|---|--------|------|------|------|-------|----|-----|
| DC performance | | | | | | | | | |
| V _{io} | Offset voltage | Vicm = +2 V | -55°C | | | 700 | μV | | |
| | | | +25°C | | | 500 | | | |
| | | | +125°C | | | 700 | | | |
| | | Vicm = +0 V | -55°C | | | 500 | | 60 | 300 |
| | | | +25°C | | | 500 | | | |
| | | | +125°C | | | 700 | | | |
| | | Vicm = -2 V | -55°C | | | 700 | | | 500 |
| | | | +25°C | | | 700 | | | |
| | | | +125°C | | | 700 | | | |
| DV _{io} | Input offset voltage drift | No load | | | 1 | | μV/°C | | |
| I _{ib} | Input bias current | No load | -55°C | | | 100 | nA | | |
| | | | +25°C | | 11 | 60 | | | |
| | | | +125°C | | | 100 | | | |
| DI _{ib} | Input offset current temp. drift | No load | | | 100 | | pA/°C | | |
| I _{io} | Input offset current | No load V _{out} = 0 V | -55°C | | | 35 | nA | | |
| | | | +25°C | | 2 | 15 | | | |
| | | | +125°C | | | 35 | | | |
| C _{in} | Differential input capacitance between +IN and -IN | | +25°C | | 8 | | pF | | |
| | Input capacitance between +IN (or -IN) and GND | | +25°C | | 2 | | | | |
| I _{CC} | Supply current per amplifier | No load | -55°C | | | 2.6 | mA | | |
| | | | +25°C | | 2 | 2.6 | | | |
| | | | +125°C | | | 2.6 | | | |
| CMR | Common mode rejection ratio | No load -V _{CC} < Vicm < +V _{CC} | -55°C | 72 | | | dB | | |
| | | | +25°C | 72 | 95 | | | | |
| | | | +125°C | 72 | | | | | |

Table 5. $+V_{CC} = +2\text{ V}$, $-V_{CC} = -2\text{ V}$, $V_{icm} = 0\text{ V}$, $T_{amb} = 25^\circ\text{C}$, loads (R_L, C_L) connected to GND (unless otherwise specified) (continued)

| Symbol | Parameter | Test conditions | Temp. | Min. | Typ. | Max. | Unit |
|-------------------------------|-----------------------------------|--|--------|------|------|------|--------------------------------------|
| AC performance | | | | | | | |
| GBP | Gain bandwidth product | $V_{out} = 200\text{ mVpp}$ $f = 100\text{ kHz}$ $R_L = 1\text{ k}\Omega$ $C_L = 100\text{ pF}$ | -55°C | 3.5 | | | MHz |
| | | | +25°C | 6 | 8 | | |
| | | | +125°C | 3.5 | | | |
| F_u | Unity gain frequency | $R_L = 1\text{ k}\Omega$, $C_L = 100\text{ pF}$ | +25°C | | 5 | | MHz |
| ϕ_m | Phase margin | $R_L = 1\text{ k}\Omega$, $C_L = 100\text{ pF}$ $G = +5$ | +25°C | | 50 | | Degrees |
| A_{VD} | Large signal voltage gain | $R_L = 10\text{ k}\Omega$ $V_{out} = -1.5\text{ V to }0.5\text{ V}$ | -55°C | 60 | | | dB |
| | | | +25°C | 70 | 80 | | |
| | | | +125°C | 60 | | | |
| SR | Slew rate | $R_L = 1\text{ k}\Omega$ $V_{out} = -1.28\text{ V to }1.28\text{ V}$ $V_{out} = 1.28\text{ V to }-1.28\text{ V}$ | -55°C | 1.7 | | | V/ μ s |
| | | | +25°C | 2 | 3.1 | | |
| | | | +125°C | 1.7 | | | |
| e_n | Equivalent input noise voltage | No load, $f = 1\text{ kHz}$ | +25°C | | 7.5 | | $\frac{\text{nV}}{\sqrt{\text{Hz}}}$ |
| i_n | Equivalent input noise current | No load, $f = 1\text{ kHz}$ | +25°C | | 0.8 | | $\frac{\text{pA}}{\sqrt{\text{Hz}}}$ |
| THD+ e_n | Total harmonic distortion + noise | $V_{out} = 3\text{ Vpp}$, $R_L = 1\text{ k}\Omega$, $C_L = 100\text{ pF}$ $G = -5.1$ | +25°C | | 0.01 | | % |
| Output characteristics | | | | | | | |
| V_{OH} | High level output voltage | $+V_{CC} = 4\text{ V}$, $-V_{CC} = 0\text{ V}$ $R_L = 1\text{ k}\Omega$ | -55°C | 3.75 | | | V |
| | | | +25°C | 3.8 | 3.9 | | |
| | | | +125°C | 3.75 | | | |
| | | $+V_{CC} = 4\text{ V}$, $-V_{CC} = 0\text{ V}$ $R_L = 10\text{ k}\Omega$ | -55°C | 3.75 | | | V |
| | | | +25°C | 3.85 | 3.95 | | |
| | | | +125°C | 3.75 | | | |
| V_{OL} | Low level output voltage | $+V_{CC} = 4\text{ V}$, $-V_{CC} = 0\text{ V}$ $R_L = 1\text{ k}\Omega$ | -55°C | | | 0.2 | V |
| | | | +25°C | | 0.05 | 0.1 | |
| | | | +125°C | | | 0.2 | |
| | | $+V_{CC} = 4\text{ V}$, $-V_{CC} = 0\text{ V}$ $R_L = 10\text{ k}\Omega$ | -55°C | | | 0.1 | V |
| | | | +25°C | | 0.03 | 0.07 | |
| | | | +125°C | | | 0.1 | |

Table 5. $+V_{CC} = +2\text{ V}$, $-V_{CC} = -2\text{ V}$, $V_{icm} = 0\text{ V}$, $T_{amb} = 25^\circ\text{C}$, loads (R_L, C_L) connected to GND (unless otherwise specified) (continued)

| Symbol | Parameter | Test conditions | Temp. | Min. | Typ. | Max. | Unit |
|-----------------|-----------------------|--|--------|------|------|------|------|
| $I_{out}^{(1)}$ | Output sink current | $V_{out} = +V_{CC}$ No load $V_{id} = -1\text{ V}$ | -55°C | 15 | | | mA |
| | | | +25°C | 20 | 35 | | |
| | | | +125°C | 15 | | | |
| | Output source current | $V_{out} = -V_{CC}$ No load $V_{id} = +1\text{ V}$ | -55°C | 10 | | | mA |
| | | | +25°C | 15 | 30 | | |
| | | | +125°C | 10 | | | |

1. These tests are performed during a very short period of time. Excessive heating can damage the device. In the application, the junction temperature must never exceed 150°C as specified in [Table 2](#).

Figure 1. Input offset voltage distribution

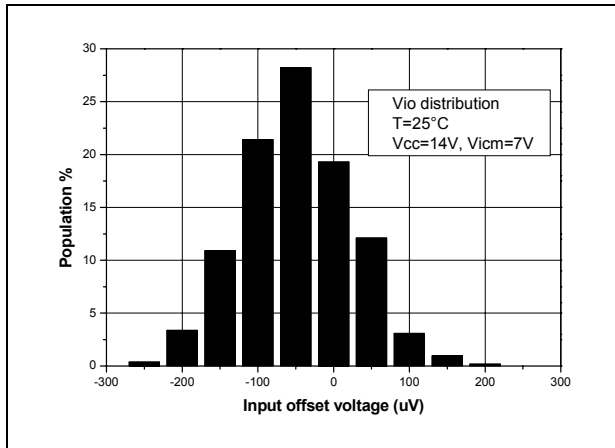

Figure 2. Input bias current vs. supply voltage

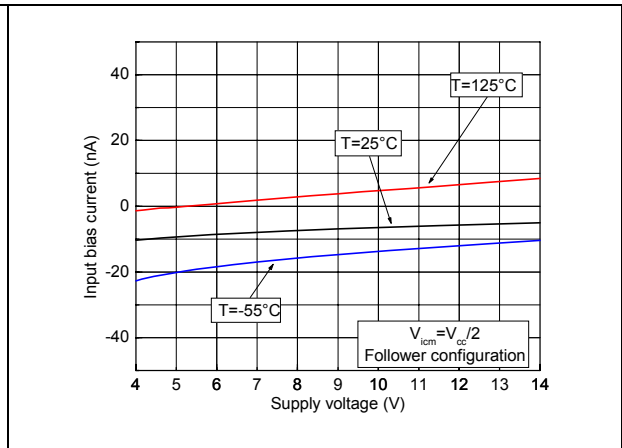

Figure 3. Input bias current vs. Vicm at VCC = 4 V

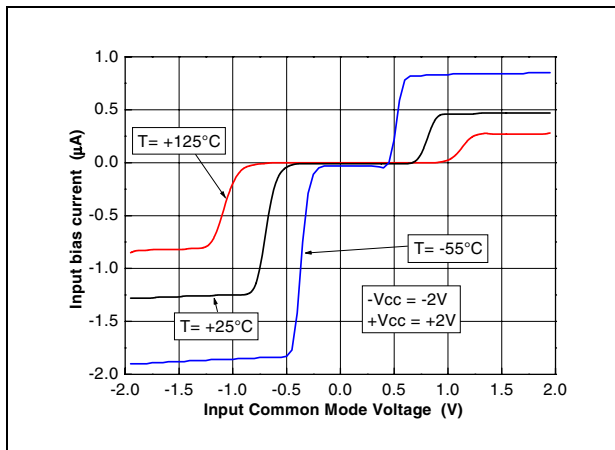

Figure 4. Input bias current vs. Vicm at VCC = 14 V

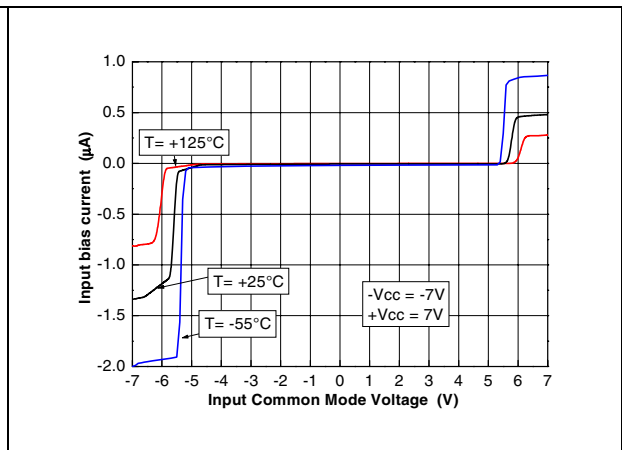

Figure 5. Supply current vs. Vicm in follower configuration at VCC = 4 V

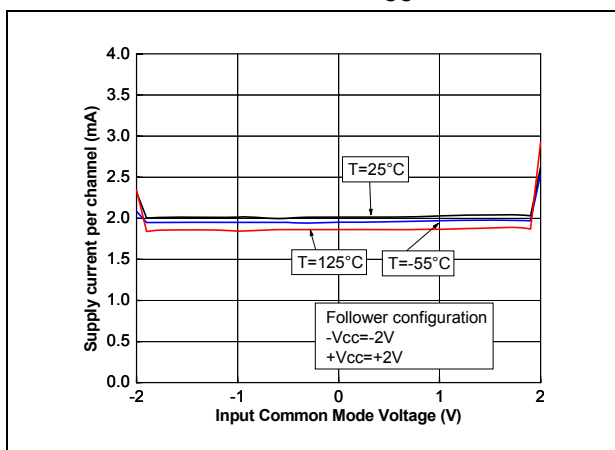

Figure 6. Supply current vs. Vicm in follower configuration at VCC = 14 V

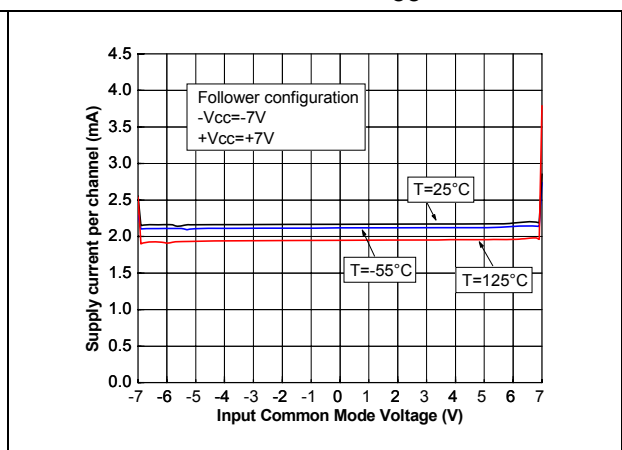

Figure 7. Supply current vs. supply voltage at $V_{icm} = V_{CC}/2$

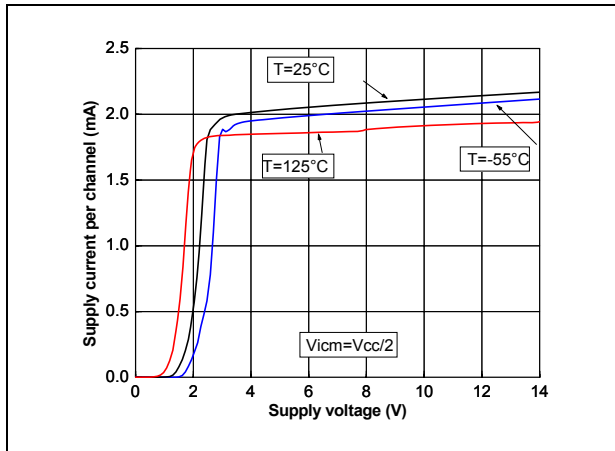

Figure 8. Output current vs. supply voltage at $V_{icm} = V_{CC}/2$

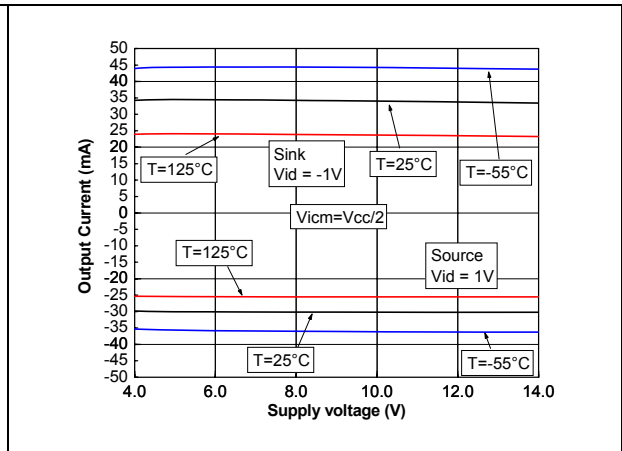

Figure 9. Output current vs. output voltage at $V_{CC} = 4 V$

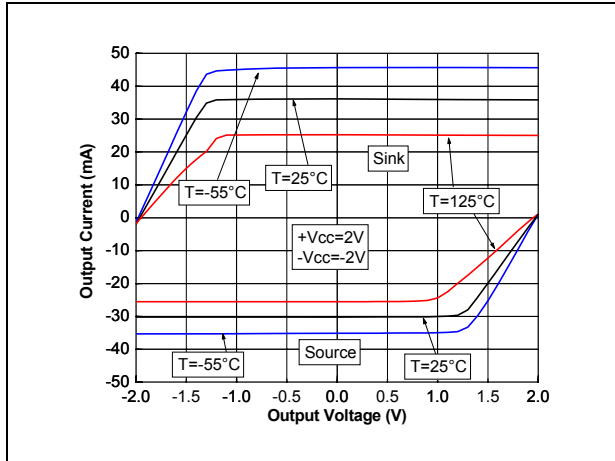

Figure 10. Output current vs. output voltage at $V_{CC} = 14 V$

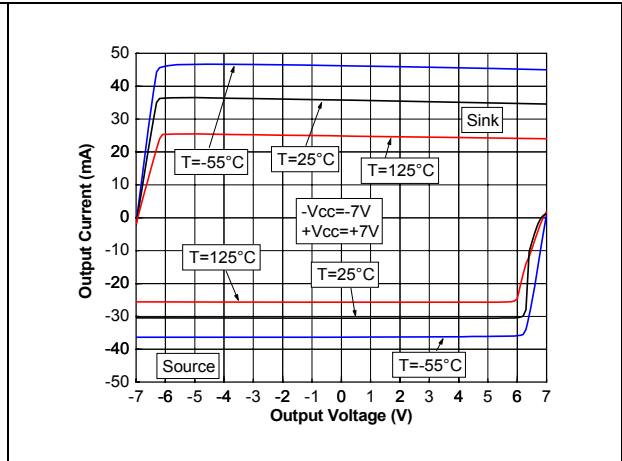

Figure 11. Differential input voltage vs. output voltage at $V_{CC} = 4 V$

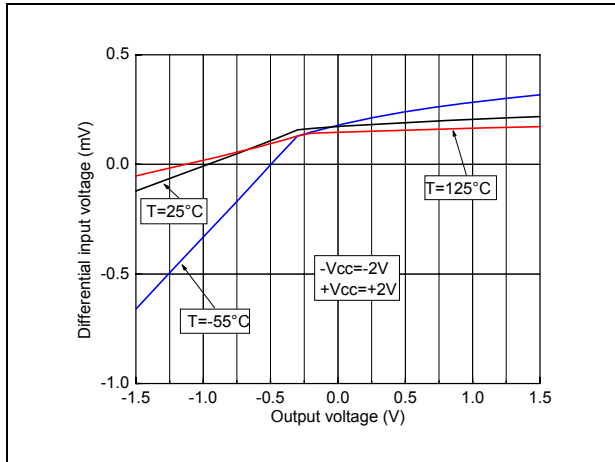

Figure 12. Differential input voltage vs. output voltage at $V_{CC} = 14 V$

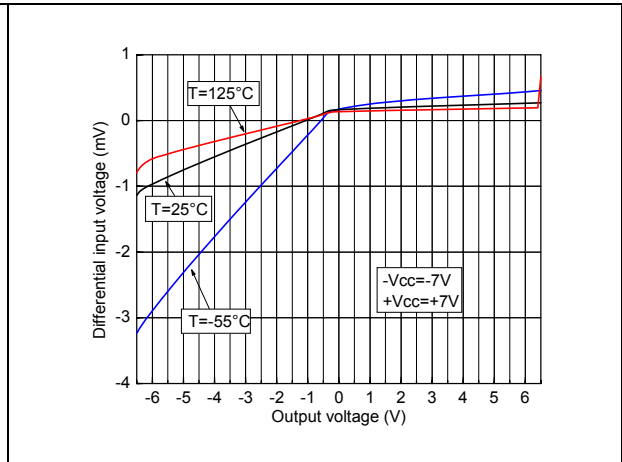

Figure 13. Noise vs. frequency at $V_{CC}=4\text{ V}$ and $V_{CC} = 14\text{ V}$ and Figure 14. Voltage gain and phase vs. frequency at $V_{CC} = 4\text{ V}$, $V_{icm} = 2\text{ V}$

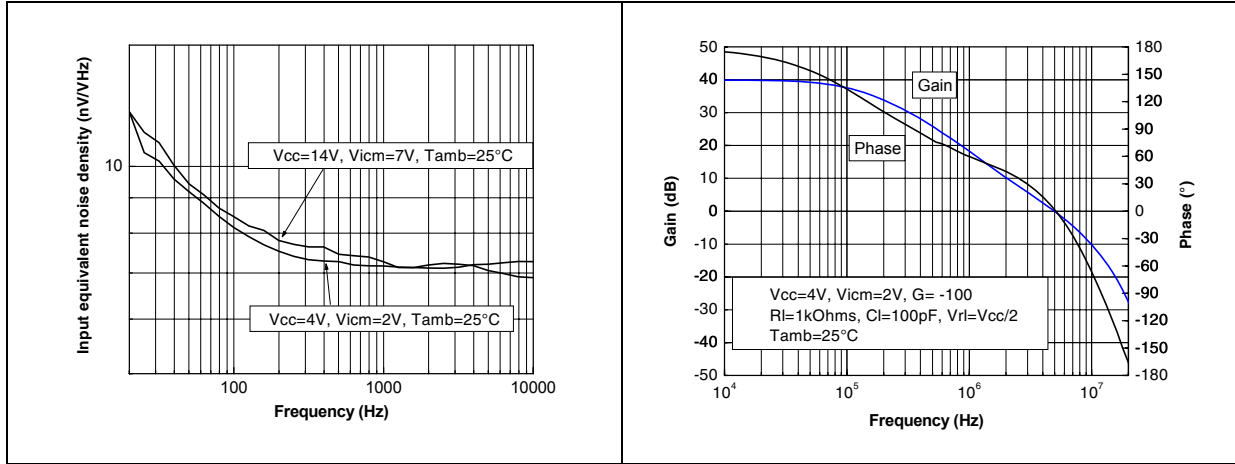

Figure 15. Voltage gain and phase vs. frequency at $V_{CC} = 4\text{ V}$, $V_{icm} = 3.5\text{ V}$ and Figure 16. Voltage gain and phase vs. frequency at $V_{CC} = 4\text{ V}$, $V_{icm} = 0.5\text{ V}$

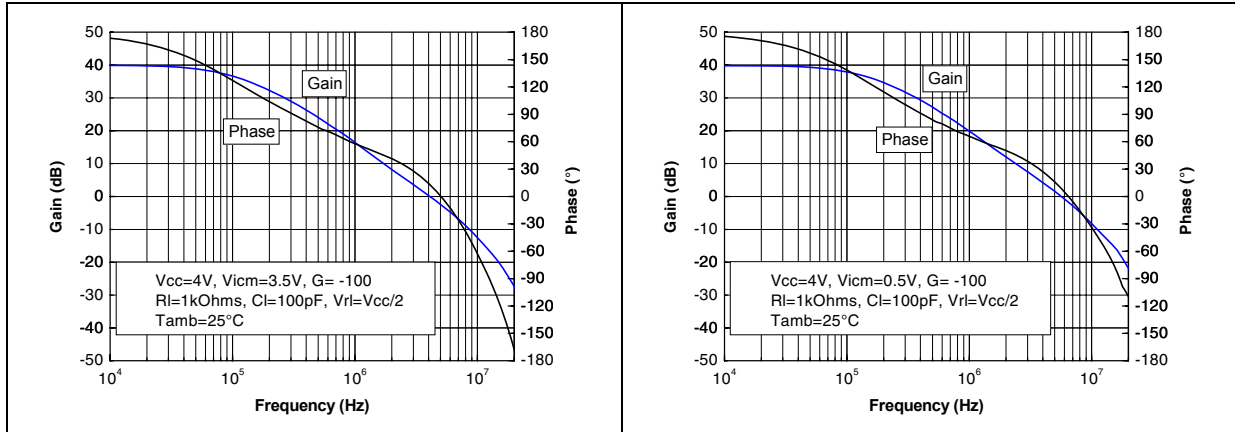

Figure 17. Voltage gain and phase vs. frequency at $V_{CC} = 14\text{ V}$, $V_{icm} = 7\text{ V}$ and Figure 18. Voltage gain and phase vs. frequency at $V_{CC} = 14\text{ V}$, $V_{icm} = 13.5\text{ V}$

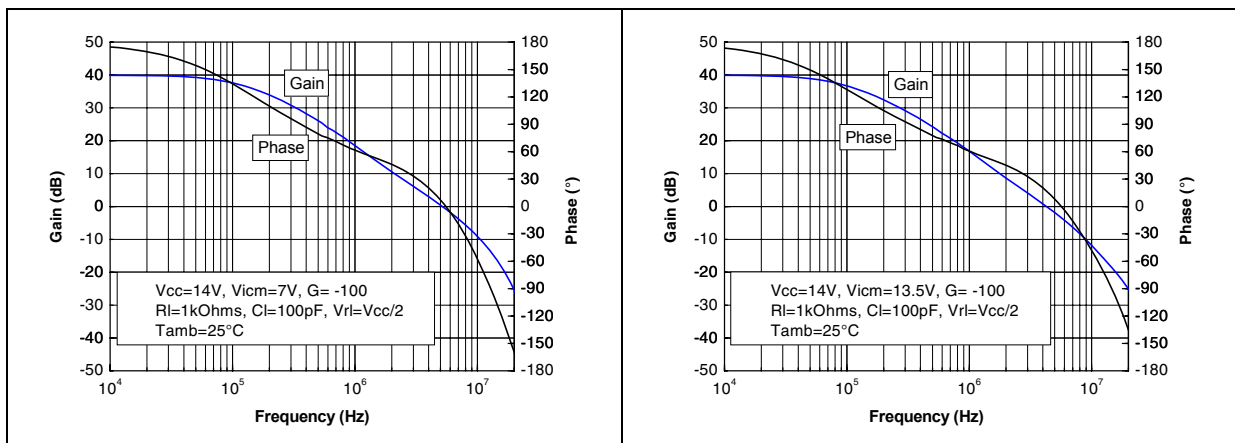

Figure 19. Voltage gain and phase vs. frequency at $V_{CC} = 14\text{ V}$, $V_{icm} = 0.5\text{ V}$

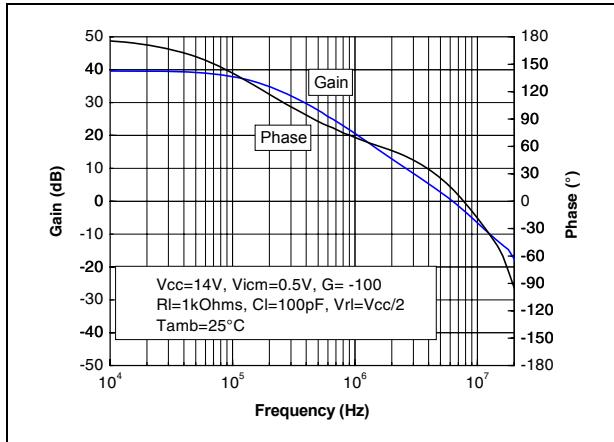

Figure 20. Positive slew rate at $V_{CC} = 4\text{ V}$

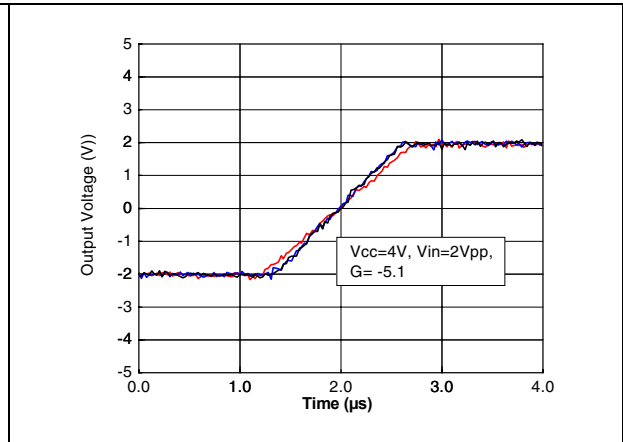

Figure 21. Negative slew rate at $V_{CC} = 4\text{ V}$

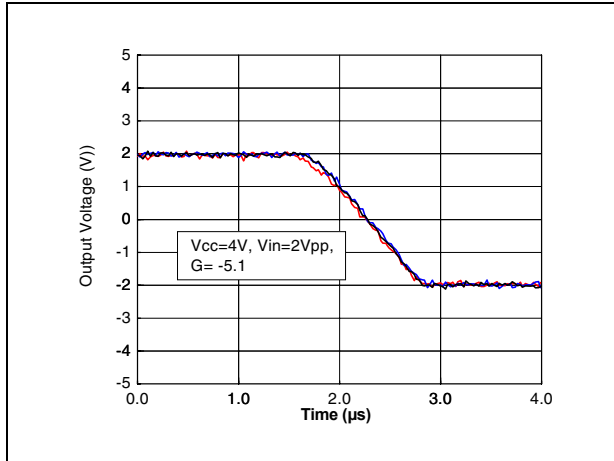

Figure 22. Positive slew rate at $V_{CC} = 14\text{ V}$

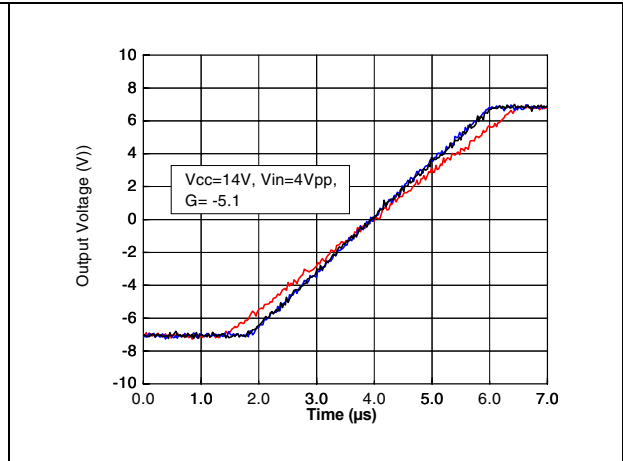
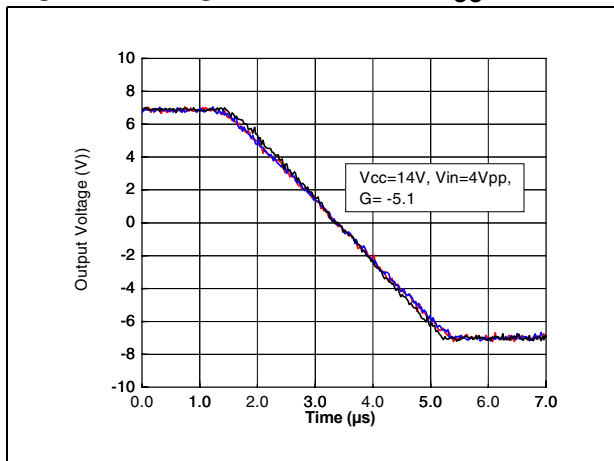

Figure 23. Negative slew rate at $V_{CC} = 14\text{ V}$



3 Achieving good stability at low gain

At low frequencies, the RHF484 can be used in a low gain configuration as shown in [Figure 24](#). At lower frequencies, the stability is not affected by the value of the gain, which can be set close to 1 V/V (0 dB), and is reduced to its simplest expression $G1=1+Rfb/Rg$. Therefore, an R-C cell is added in the gain network so that the gain is increased (up to 5) at higher frequencies (where the stability of the amplifier could be affected). At higher frequencies, the gain becomes $G2=1+Rfb/(Rg//R)$.

Figure 24. Low gain configuration

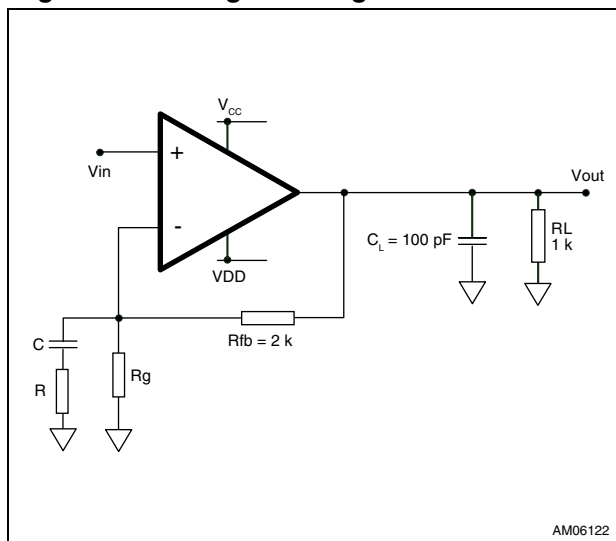

AM06122

Figure 25. Closed-loop gain

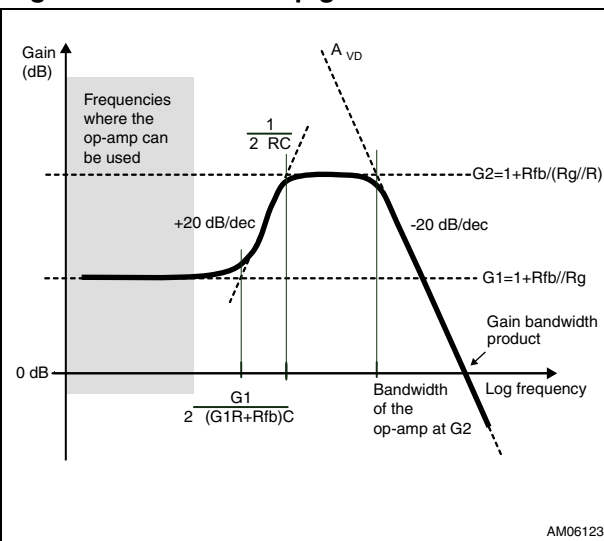

AM06123

Rg becomes a complex impedance. The closed-loop gain features a variation in frequency and can be expressed as:

$$\text{Gain} = G1 \frac{1 + jC\omega \times \left(\frac{G1R + Rfb}{G1} \right)}{1 + jCR\omega}$$

where a pole appears at $1/2\pi RC$ and a zero at $G1/2\pi(G1R+Rfb)C$. The frequency can be plotted as shown in [Figure 25](#).

Table 6. External components versus low-frequency gain

| G1 (V/V) | R (Ω) | C (nF) | Rg (Ω) | Rfb (Ω) |
|----------|----------------|---------------|-----------------|------------------|
| 1.1 | 510 | 1 | 20k | 2k |
| 2 | 510 | 1 | 2k | 2k |
| 3 | 510 | 1 | 1k | 2k |
| 4 | 510 | 1 | 750 | 2.4k |
| 5 | Not connected | Not connected | 820 | 3.3k |

4 Package information

In order to meet environmental requirements, ST offers these devices in different grades of ECOPACK[®] packages, depending on their level of environmental compliance. ECOPACK[®] specifications, grade definitions and product status are available at: www.st.com. ECOPACK[®] is an ST trademark.

Figure 26. Wide ceramic Flat-14 package mechanical drawing.

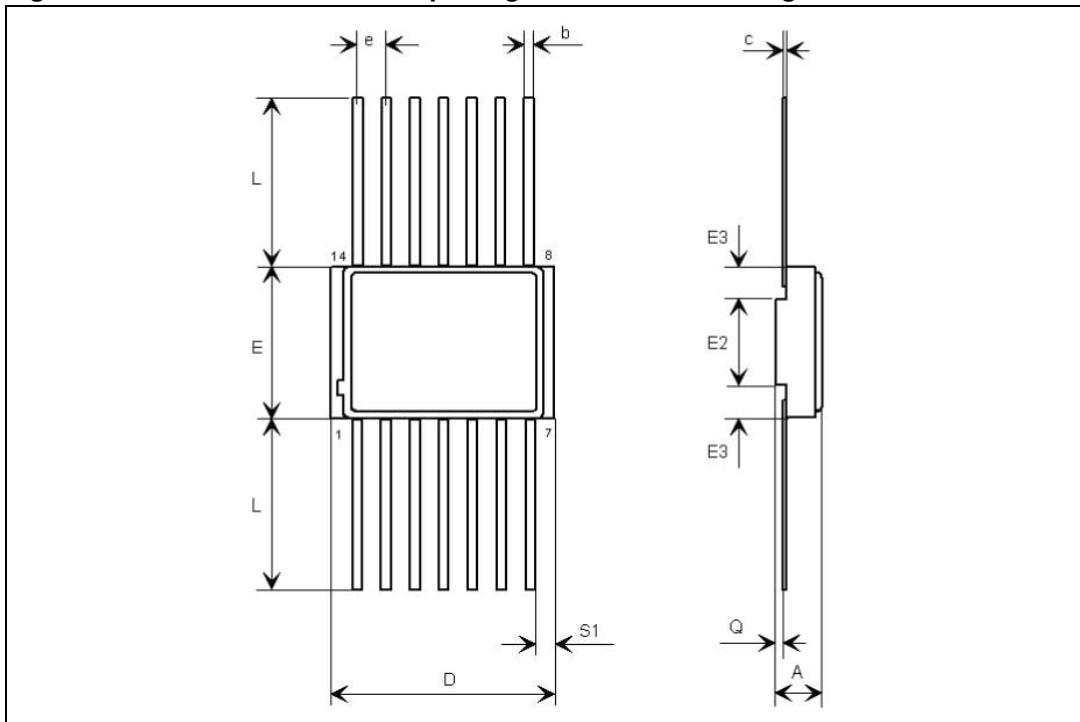

Note: The upper metallic lid is not electrically connected to any pins, nor to the IC die inside the package. Connecting unused pins or metal lid to ground or Vcc will not affect the electrical characteristics.

Table 7. Wide ceramic Flat-14 W package mechanical data

| Ref. | Dimensions | | | | | |
|------|-------------|------|-------|--------|-------|------|
| | Millimeters | | | inches | | |
| | Min. | Typ. | Max. | Min. | Typ. | Max. |
| A | 1.93 | 2.11 | 2.29 | .076 | .083 | .090 |
| b | 0.38 | 0.43 | 0.48 | .015 | .017 | .019 |
| c | 0.10 | 0.13 | 0.18 | .004 | .005 | .007 |
| D | 9.71 | 9.91 | 10.11 | .382 | 0.390 | .398 |
| E | 7.27 | 7.42 | 7.57 | .286 | .292 | .298 |
| E2 | | 5.4 | | | .213 | |
| E3 | 0.76 | | | .030 | | |
| e | | 1.27 | | | .050 | |
| L | 6.3 | | 6.6 | .248 | | .260 |
| Q | 0.20 | | 0.28 | .008 | | .011 |
| S1 | 0.13 | | | .005 | | |

5 Ordering information

Table 8. Order codes

| Order code | Description | Temperature range | Package | Marking |
|-------------|---------------------|-------------------|-----------|-----------------|
| RHF484K1 | Engineering Samples | -55°C to +125°C | Flat-14 W | RHF484K1 |
| RHF484K-01V | Flight Models | | | 5962F0822201VXC |

Note: Contact your ST sales office for information on specific conditions for products in die form.

6 Revision history

Table 9. Document revision history

| Date | Revision | Changes |
|-------------|----------|------------------|
| 26-Apr-2011 | 1 | Initial release. |

Please Read Carefully:

Information in this document is provided solely in connection with ST products. STMicroelectronics NV and its subsidiaries ("ST") reserve the right to make changes, corrections, modifications or improvements, to this document, and the products and services described herein at any time, without notice.

All ST products are sold pursuant to ST's terms and conditions of sale.

Purchasers are solely responsible for the choice, selection and use of the ST products and services described herein, and ST assumes no liability whatsoever relating to the choice, selection or use of the ST products and services described herein.

No license, express or implied, by estoppel or otherwise, to any intellectual property rights is granted under this document. If any part of this document refers to any third party products or services it shall not be deemed a license grant by ST for the use of such third party products or services, or any intellectual property contained therein or considered as a warranty covering the use in any manner whatsoever of such third party products or services or any intellectual property contained therein.

UNLESS OTHERWISE SET FORTH IN ST'S TERMS AND CONDITIONS OF SALE ST DISCLAIMS ANY EXPRESS OR IMPLIED WARRANTY WITH RESPECT TO THE USE AND/OR SALE OF ST PRODUCTS INCLUDING WITHOUT LIMITATION IMPLIED WARRANTIES OF MERCHANTABILITY, FITNESS FOR A PARTICULAR PURPOSE (AND THEIR EQUIVALENTS UNDER THE LAWS OF ANY JURISDICTION), OR INFRINGEMENT OF ANY PATENT, COPYRIGHT OR OTHER INTELLECTUAL PROPERTY RIGHT.

UNLESS EXPRESSLY APPROVED IN WRITING BY AN AUTHORIZED ST REPRESENTATIVE, ST PRODUCTS ARE NOT RECOMMENDED, AUTHORIZED OR WARRANTED FOR USE IN MILITARY, AIR CRAFT, SPACE, LIFE SAVING, OR LIFE SUSTAINING APPLICATIONS, NOR IN PRODUCTS OR SYSTEMS WHERE FAILURE OR MALFUNCTION MAY RESULT IN PERSONAL INJURY, DEATH, OR SEVERE PROPERTY OR ENVIRONMENTAL DAMAGE. ST PRODUCTS WHICH ARE NOT SPECIFIED AS "AUTOMOTIVE GRADE" MAY ONLY BE USED IN AUTOMOTIVE APPLICATIONS AT USER'S OWN RISK.

Resale of ST products with provisions different from the statements and/or technical features set forth in this document shall immediately void any warranty granted by ST for the ST product or service described herein and shall not create or extend in any manner whatsoever, any liability of ST.

ST and the ST logo are trademarks or registered trademarks of ST in various countries.

Information in this document supersedes and replaces all information previously supplied.

The ST logo is a registered trademark of STMicroelectronics. All other names are the property of their respective owners.

© 2011 STMicroelectronics - All rights reserved

STMicroelectronics group of companies

Australia - Belgium - Brazil - Canada - China - Czech Republic - Finland - France - Germany - Hong Kong - India - Israel - Italy - Japan - Malaysia - Malta - Morocco - Philippines - Singapore - Spain - Sweden - Switzerland - United Kingdom - United States of America

www.st.com