

### Features

$BV_{CEO}$	80 V
$I_C$ (max)	5 A
$H_{FE}$ at 10 V - 150 mA	> 70
Operating temperature range	-65°C to +200°C

- Hi-Rel PNP bipolar transistor
- Linear gain characteristics
- ESCC qualified
- European preferred part list - EPPL
- Radiation level: lot specific total dose contact marketing for specified level

### Description

The 2N5153HR is a silicon planar epitaxial PNP transistor in TO-39, TO-257 and SMD.5 packages. It is specifically designed for aerospace Hi-Rel applications and ESCC qualified according to the 5204-002 specification. In case of conflict between this datasheet and ESCC detailed specification, the latter prevails.

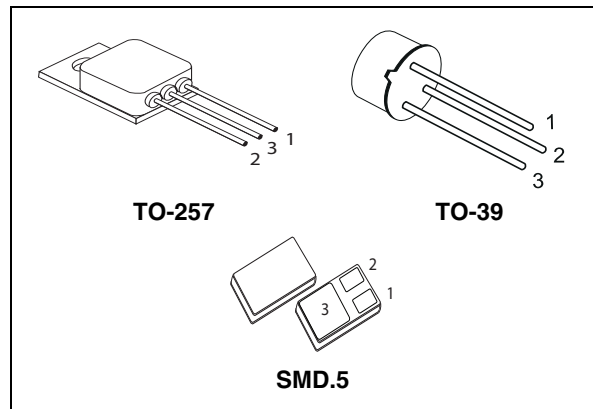

Figure 1. Internal schematic diagram

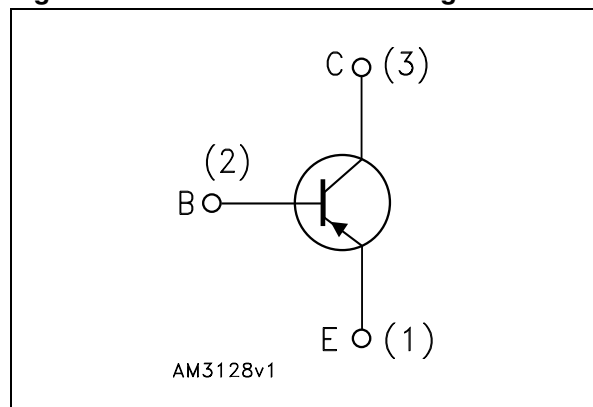

Table 1. Device summary

Order codes	Packages	Lead finish	Marking	Type	EPPL	Packaging
2N5153HR	TO-39	Gold Solder Dip	520400201 520400202	ESCC Flight		Strip pack
2N5153SHR	SMD.5	Gold	520400206	ESCC Flight	Yes	Strip pack
2N5153ESYHR	TO-257	Gold Solder Dip	520400204 520400205	ESCC Flight		Strip pack
2N5153T1	TO-39	Gold	2N5153T1	Engineering model		Strip pack
2N5153S1	SMD.5	Gold	2N5153S1	Engineering model		Strip pack
2N5153ESY	TO-257	Gold	2N5153ESY	Engineering model		Strip pack

# 1 Electrical ratings

**Table 2. Absolute maximum ratings**

Symbol	Parameter	Value	Unit
$V_{CBO}$	Collector-base voltage ( $I_E = 0$ )	-100	V
$V_{CEO}$	Collector-emitter voltage ( $I_B = 0$ )	-80	V
$V_{EBO}$	Emitter-base voltage ( $I_C = 0$ )	-5.5	V
$I_C$	Collector current	-5	A
$P_{TOT}$	Total dissipation at $T_{amb} \leq 25\text{ °C}$		
	for 2N5153HR	1	W
	for 2N5153ESYHRB	3.3	W
	for Root part number 2	3.3	W
	$T_C \leq 25\text{ °C}$		
	for 2N5153HR	10	W
for 2N5153ESYHRB	35	W	
for Root part number 2	35	W	
$T_{STG}$	Storage temperature	-65 to 200	°C
$T_J$	Max. operating junction temperature	200	°C

**Table 3. Thermal data for through-hole packages**

Symbol	Parameter	TO-39	TO-257	Unit
$R_{thJC}$	Thermal resistance junction-case max	17.5	5	°C/W
$R_{thJA}$	Thermal resistance junction-ambient max	175	53	°C/W

**Table 4. Thermal data for SMD package**

Symbol	Parameter	SMD.5	Unit
$R_{thJC}$	Thermal resistance junction-case max	5	°C/W

## 2 Electrical characteristics

$T_{\text{case}} = 25\text{ °C}$  unless otherwise specified

**Table 5. Electrical characteristics**

Symbol	Parameter	Test conditions	Min.	Typ.	Max.	Unit
$I_{\text{CES}}$	Collector cut-off current ( $I_{\text{E}} = 0$ )	$V_{\text{CB}} = -60\text{ V}$ $V_{\text{CB}} = -60\text{ V}$ $T_{\text{amb}} = 150\text{ °C}$			-1 -10	$\mu\text{A}$ $\mu\text{A}$
$I_{\text{EBO}}$	Emitter cut-off current ( $I_{\text{C}} = 0$ )	$V_{\text{EB}} = -4\text{ V}$ $V_{\text{EB}} = -5.5\text{ V}$			-1 -1	$\mu\text{A}$ $\text{mA}$
$I_{\text{CEO}}$	Collector cut-off current ( $I_{\text{B}} = 0$ )	$V_{\text{CE}} = -40\text{ V}$			-50	$\mu\text{A}$
$V_{(\text{BR})\text{CEO}}^{(1)}$	Collector-emitter breakdown voltage ( $I_{\text{B}} = 0$ )	$I_{\text{C}} = -100\text{ mA}$	-80			V
$V_{\text{CE}(\text{sat})}^{(1)}$	Collector-emitter saturation voltage	$I_{\text{C}} = -5\text{ A}$ $I_{\text{B}} = -0.5\text{ A}$			-1.5	V
$V_{\text{BE}(\text{sat})}^{(1)}$	Base-emitter saturation voltage	$I_{\text{C}} = -2.5\text{ A}$ $I_{\text{B}} = -0.25\text{ A}$ $I_{\text{C}} = -5\text{ A}$ $I_{\text{B}} = -0.5\text{ A}$			-1.45 -2.2	V V
$h_{\text{FE}}^{(1)}$	DC current gain	$I_{\text{C}} = -50\text{ mA}$ $V_{\text{CE}} = -5\text{ V}$ $I_{\text{C}} = -2.5\text{ A}$ $V_{\text{CE}} = -5\text{ V}$ $I_{\text{C}} = -5\text{ A}$ $V_{\text{CE}} = -5\text{ V}$ $I_{\text{C}} = -2.5\text{ A}$ $V_{\text{CE}} = -5\text{ V}$ $T_{\text{amb}} = -55\text{ °C}$	50 70 40 35		200	
$h_{\text{fe}}$	AC forward current transfer ratio	$V_{\text{CE}} = -5\text{ V}$ $I_{\text{C}} = -500\text{ mA}$ $f = 20\text{ MHz}$	3.5			
$C_{\text{OBO}}$	Output capacitance	$I_{\text{E}} = 0$ $V_{\text{CB}} = -10\text{ V}$ $f = 1\text{ MHz}$			250	pF
$t_{\text{on}}$	Turn-on time	$V_{\text{CC}} = -30\text{ V}$ $V_{\text{BB}} = -4\text{ V}$ $V_{\text{in}} \cong -51\text{ V}$ $I_{\text{C}} = 5\text{ A}$ $I_{\text{B1}} = -I_{\text{B2}} = -0.5\text{ A}$			0.5	$\mu\text{s}$
$t_{\text{off}}$	Turn-off time	$V_{\text{CC}} = -30\text{ V}$ $V_{\text{BB}} = -4\text{ V}$ $V_{\text{in}} \cong -51\text{ V}$ $I_{\text{C}} = -5\text{ A}$ $I_{\text{B1}} = -I_{\text{B2}} = -0.5\text{ A}$			1.3	$\mu\text{s}$

1. Pulsed duration = 300  $\mu\text{s}$ , duty cycle  $\leq 1.5\%$

## 2.1 Electrical characteristics (curves)

Figure 2.  $h_{FE} @ V_{CE} = 5 V$

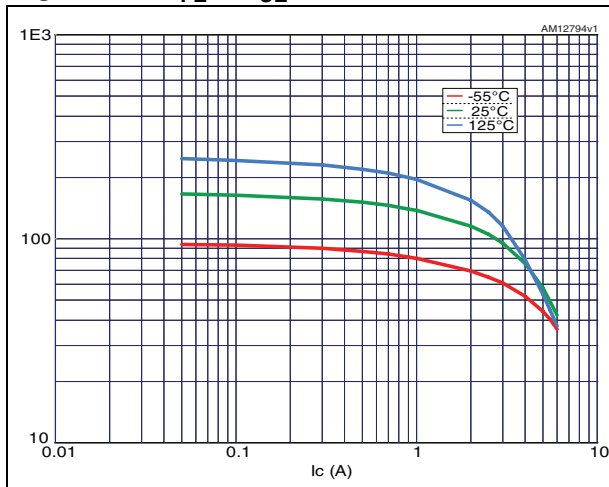

Figure 3.  $V_{CEsat} @ h_{FE} = 10$

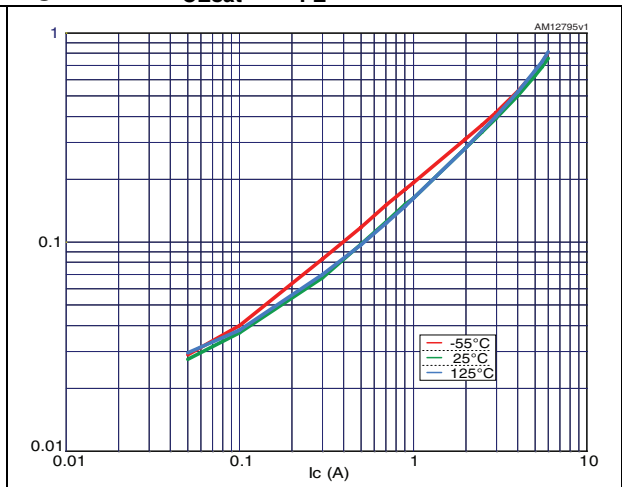

Figure 4.  $V_{BEsat} @ h_{FE} = 10$

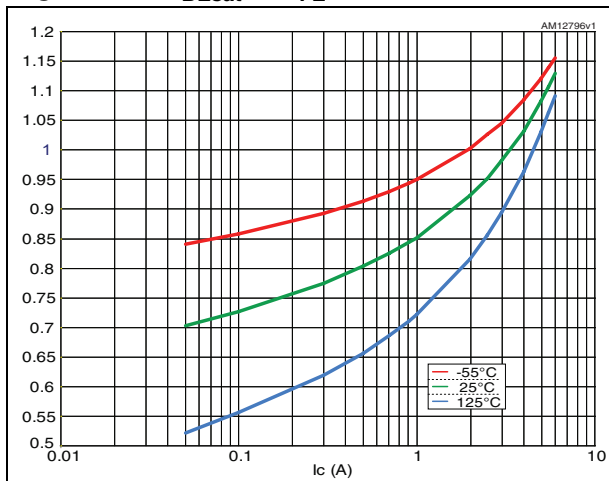
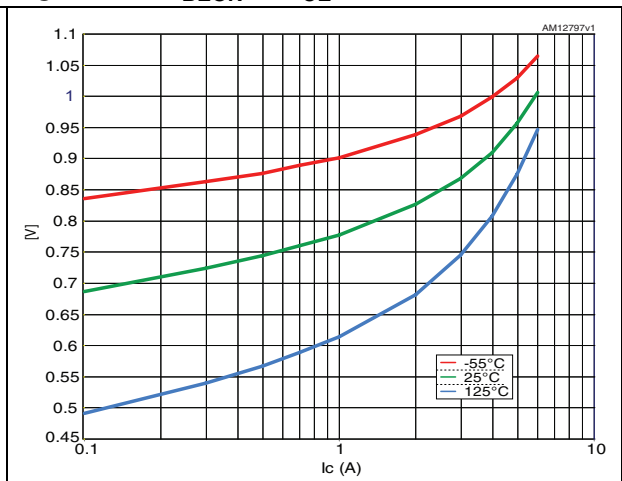
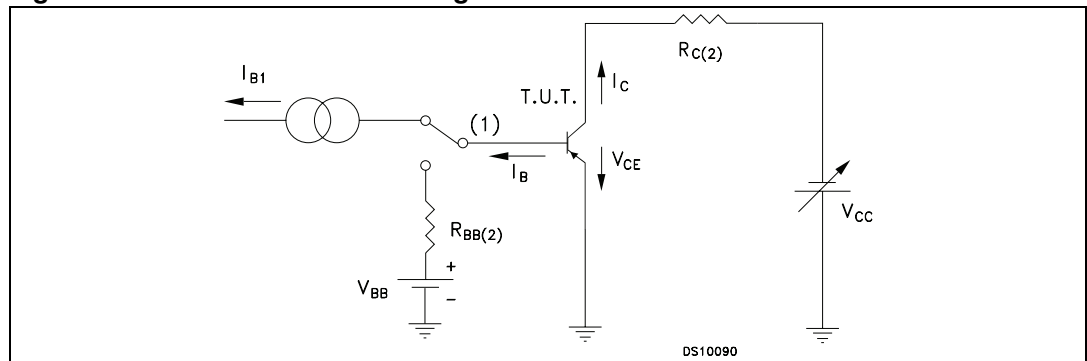

Figure 5.  $V_{BEON} @ V_{CE} = 5 V$



## 2.2 Test circuit

Figure 6. Resistive load switching test circuit



1. Fast electronic switch
2. Non-inductive resistor

### 3 Package mechanical data

In order to meet environmental requirements, ST offers these devices in different grades of ECOPACK<sup>®</sup> packages, depending on their level of environmental compliance. ECOPACK<sup>®</sup> specifications, grade definitions and product status are available at: [www.st.com](http://www.st.com). ECOPACK<sup>®</sup> is an ST trademark.

**TO-257 mechanical data**

DIM.	mm.		
	Min.	Typ.	Max.
A	4.83		5.08
A1	0.89		1.14
A2		3.05	
b	0.64		1.02
b1	0.64	0.76	0.89
D	16.38		16.89
D1	10.41		10.92
D2			0.97
e		2.54	
E	10.41		10.67
L	12.70		19.05
L1	13.39		13.64
P	3.56		3.81

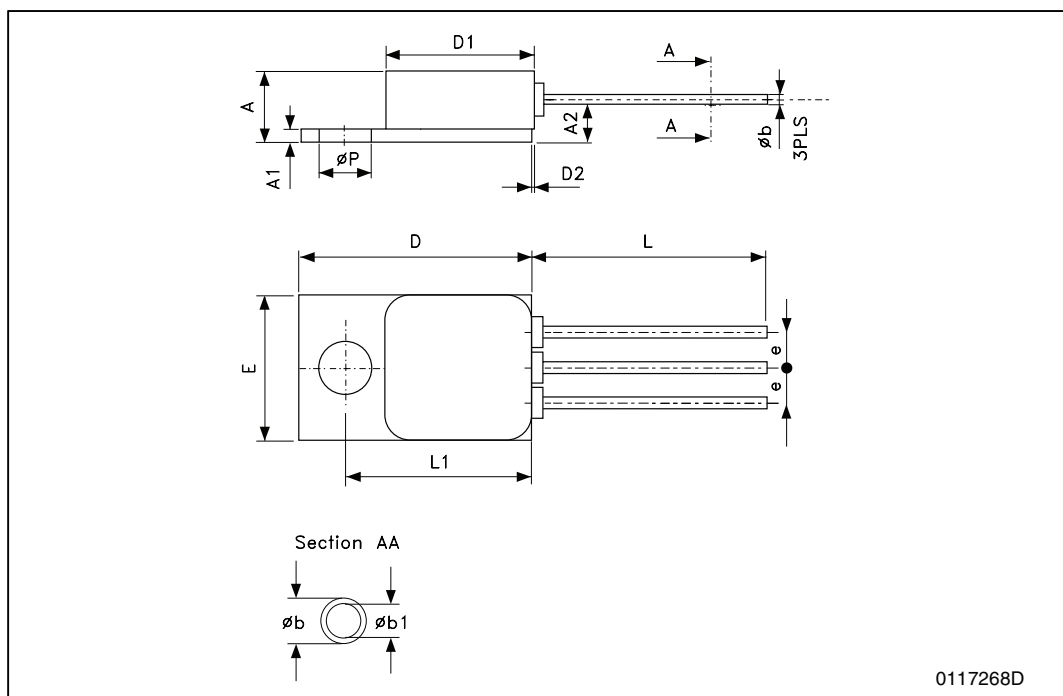

0117268D

**TO-39 mechanical data**

DIM.	mm.		
	Min.	Typ.	Max.
A	12.70		
B			0.49
D			6.60
E			8.51
F			9.40
G		5.08	
H			1.02
I			0.86
L		45°	

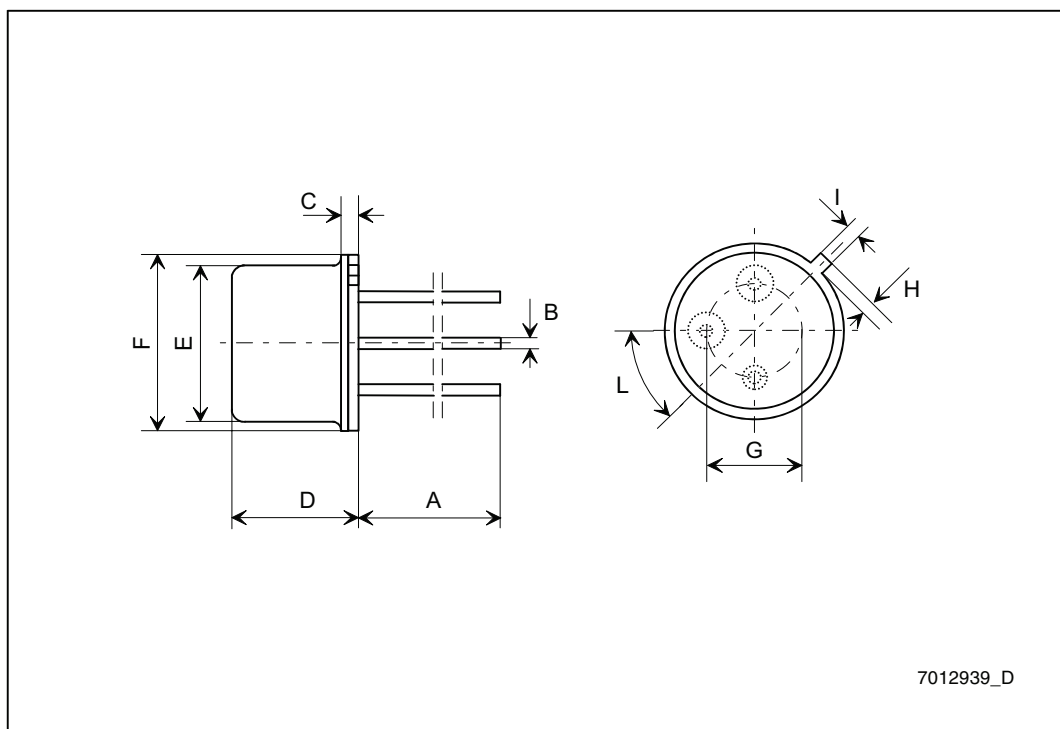

7012939\_D

**SMD.5 mechanical data**

Dim.	mm.		
	Min.	Typ.	Max.
A	2.84	3.00	3.15
A1	0.25	0.38	0.51
b	7.13	7.26	7.39
b1	5.58	5.72	5.84
b2	2.28	2.41	2.54
b3	2.92	3.05	3.18
D	10.03	10.16	10.28
D1		0.76	
E	7.39	7.52	7.64
e		1.91	

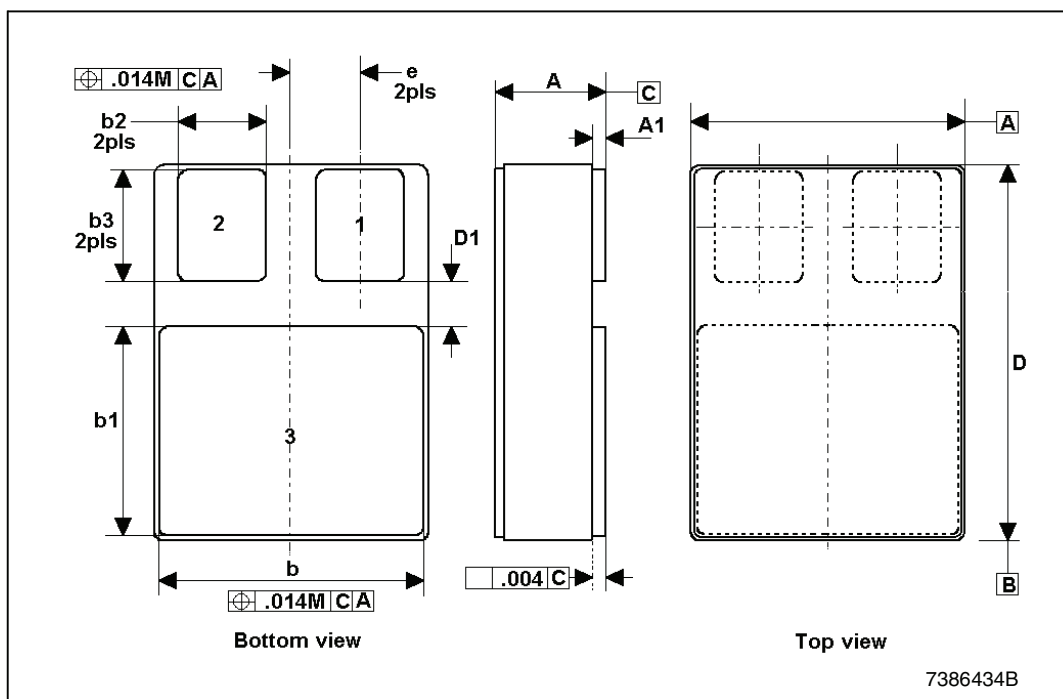

## 4 Revision history

**Table 6. Document revision history**

Date	Revision	Changes
10-Dec-2008	1	Initial release
08-Jan-2010	2	Modified <a href="#">Table 1 on page 1</a>
12-Sep-2012	3	Added: <a href="#">Section 2.1: Electrical characteristics (curves) on page 4</a>

**Please Read Carefully:**

Information in this document is provided solely in connection with ST products. STMicroelectronics NV and its subsidiaries ("ST") reserve the right to make changes, corrections, modifications or improvements, to this document, and the products and services described herein at any time, without notice.

All ST products are sold pursuant to ST's terms and conditions of sale.

Purchasers are solely responsible for the choice, selection and use of the ST products and services described herein, and ST assumes no liability whatsoever relating to the choice, selection or use of the ST products and services described herein.

No license, express or implied, by estoppel or otherwise, to any intellectual property rights is granted under this document. If any part of this document refers to any third party products or services it shall not be deemed a license grant by ST for the use of such third party products or services, or any intellectual property contained therein or considered as a warranty covering the use in any manner whatsoever of such third party products or services or any intellectual property contained therein.

**UNLESS OTHERWISE SET FORTH IN ST'S TERMS AND CONDITIONS OF SALE ST DISCLAIMS ANY EXPRESS OR IMPLIED WARRANTY WITH RESPECT TO THE USE AND/OR SALE OF ST PRODUCTS INCLUDING WITHOUT LIMITATION IMPLIED WARRANTIES OF MERCHANTABILITY, FITNESS FOR A PARTICULAR PURPOSE (AND THEIR EQUIVALENTS UNDER THE LAWS OF ANY JURISDICTION), OR INFRINGEMENT OF ANY PATENT, COPYRIGHT OR OTHER INTELLECTUAL PROPERTY RIGHT.**

**UNLESS EXPRESSLY APPROVED IN WRITING BY TWO AUTHORIZED ST REPRESENTATIVES, ST PRODUCTS ARE NOT RECOMMENDED, AUTHORIZED OR WARRANTED FOR USE IN MILITARY, AIR CRAFT, SPACE, LIFE SAVING, OR LIFE SUSTAINING APPLICATIONS, NOR IN PRODUCTS OR SYSTEMS WHERE FAILURE OR MALFUNCTION MAY RESULT IN PERSONAL INJURY, DEATH, OR SEVERE PROPERTY OR ENVIRONMENTAL DAMAGE. ST PRODUCTS WHICH ARE NOT SPECIFIED AS "AUTOMOTIVE GRADE" MAY ONLY BE USED IN AUTOMOTIVE APPLICATIONS AT USER'S OWN RISK.**

Resale of ST products with provisions different from the statements and/or technical features set forth in this document shall immediately void any warranty granted by ST for the ST product or service described herein and shall not create or extend in any manner whatsoever, any liability of ST.

ST and the ST logo are trademarks or registered trademarks of ST in various countries.

Information in this document supersedes and replaces all information previously supplied.

The ST logo is a registered trademark of STMicroelectronics. All other names are the property of their respective owners.

© 2012 STMicroelectronics - All rights reserved

STMicroelectronics group of companies

Australia - Belgium - Brazil - Canada - China - Czech Republic - Finland - France - Germany - Hong Kong - India - Israel - Italy - Japan - Malaysia - Malta - Morocco - Philippines - Singapore - Spain - Sweden - Switzerland - United Kingdom - United States of America

[www.st.com](http://www.st.com)