



RHFL4913XX25 RHFL4913XX33 - RHFL4913XX50

Rad-hard positive fixed voltage regulator

Features

- 2 and 3 A low dropout voltage
- Embedded overtemperature, overcurrent protections
- Adjustable current limitation
- Output overload monitoring/signalling
- Fixed 2.5 V, 3.3 V, 5.0 V output voltages
- Inhibit (ON/OFF) TTL-compatible control
- Programmable output short-circuit current
- Remote sensing operation
- Rad-hard: tested up to 300 krad Mil Std 883E Method 1019.6 and low dose rate conditions
- Heavy ions SEL immune

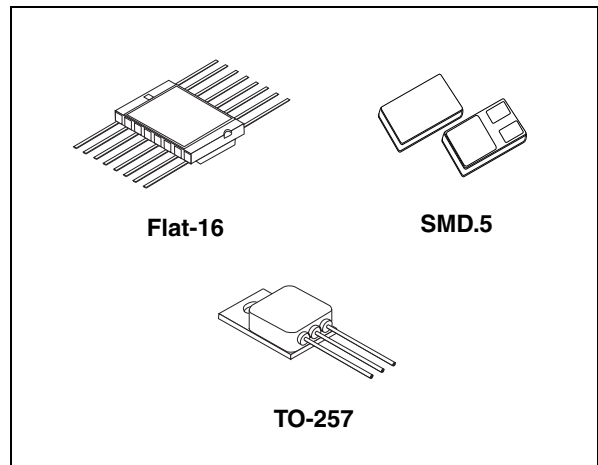

specifically intended for space and harsh radiation environments. Input supply range is up to 12 V. RHFL4913 fixed is QML-V qualified, DSCC SMD are 5962F02534 / 02535 / 02536.

Description

The RHFL4913 fixed is a high performance Rad-hard positive voltage regulator family. Available in various hermetic ceramic packages, it is

Figure 1. Block diagram for package SMD.5 and TO-257

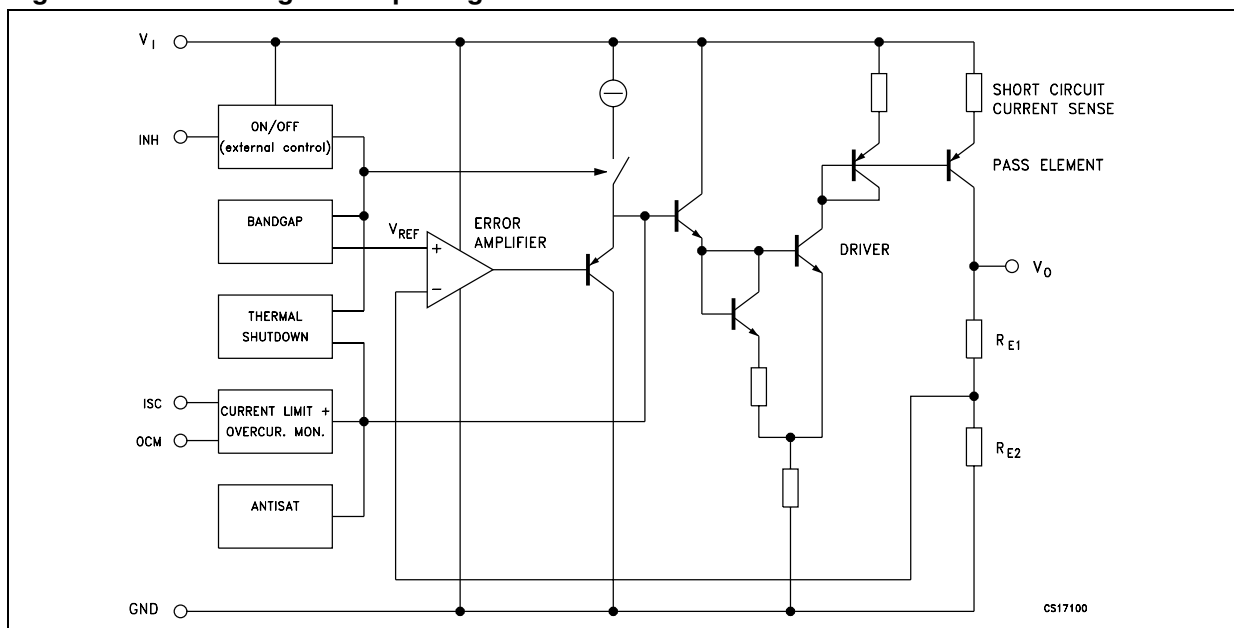

Contents

1	Diagram	3
2	Pin configuration	4
3	Maximum ratings	5
4	Electrical characteristics	6
5	Device description	8
	5.1 Low pin count package limitations	8
	5.2 SENSE pin	8
	5.3 Inhibit ON-OFF control	8
	5.4 Overtemperature protection	8
	5.5 Overcurrent protection	8
	5.6 OCM pin	9
	5.7 Alternate to	9
6	Application information	10
	6.1 Remote sensing operation	10
7	Notes about Flat-16 package	11
	7.1 Radiation performances	11
	7.2 Die information	11
8	Package mechanical data	12
9	Ordering information	16
10	Revision history	18

1 Diagram

Figure 2. Block diagram for package Flat-16

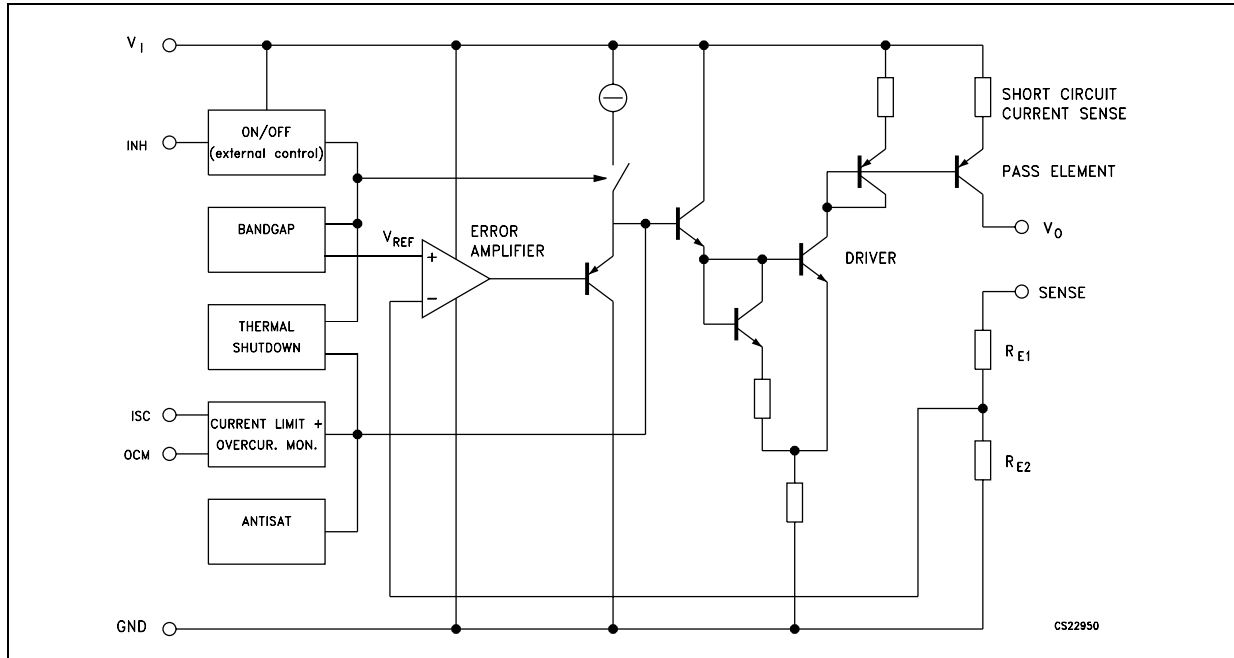

2 Pin configuration

Figure 3. Pin configuration (top view for Flat-16, bottom view for SMD.5)

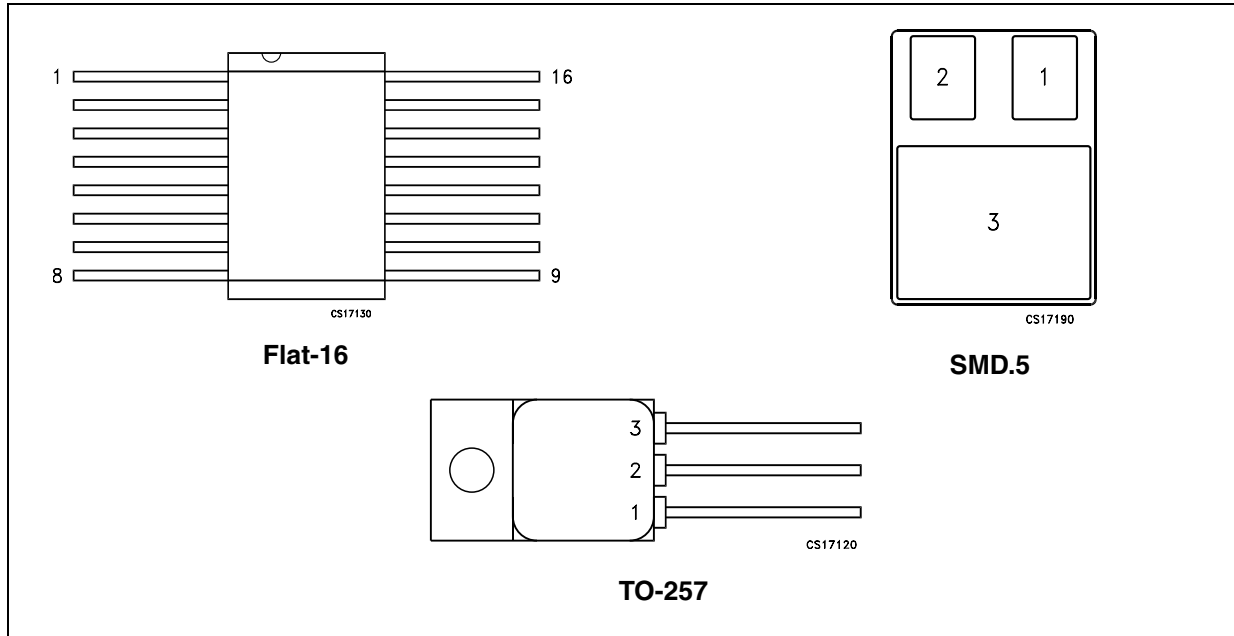

Table 1. Pin description

Pin name	Flat-16 ⁽¹⁾	SMD.5 ⁽²⁾	TO-257
V _O	1, 2, 6, 7	1	3
V _I	3, 4, 5	2	1
GND	13	3	2
I _{sc}	8		
OCM	10		
INHIBIT	14		
SENSE	16		
NC	9, 11, 12, 15		

1. The upper metallic package lid and the bottom metallization are neither connected to regulator die nor to package terminals, hence electrically floating.

2. The upper metallic package lid is neither connected to regulator die nor to package terminals, hence electrically floating.

3 Maximum ratings

Table 2. Absolute maximum ratings ⁽¹⁾

Symbol	Parameter	Value	Unit
V_I	DC input voltage, $V_I - V_{\text{GROUND}}$	14	V
I_O	Output current	RHFL4913S, ESY	3
		RHFL4913KP	2
P_D	$T_C = 25^\circ\text{C}$ power dissipation	KP, S Versions	15
		ESY Version	10
T_{STG}	Storage temperature range	-65 to +150	$^\circ\text{C}$
T_{OP}	Operating junction temperature range	-55 to +150	$^\circ\text{C}$
T_J	Junction temperature ⁽²⁾	+150	$^\circ\text{C}$
ESD	Electrostatic discharge capability	Class 3	

1. Exceeding maximum ratings may damage the device.
2. Internally limited to about maximum +175 $^\circ\text{C}$ by thermal shutdown circuit.

Table 3. Thermal data

Symbol	Parameter	Flat-16	TO-257	SMD.5	Unit
R_{thJC}	Thermal resistance junction-case max.	8.3	12.5	8.3	$^\circ\text{C}/\text{W}$
T_{SOLD}	Maximum soldering temperature, 10 sec.	300			$^\circ\text{C}$

4 Electrical characteristics

$T_J = 25\text{ °C}$, $V_I = V_O + 2.5\text{ V}$, $C_I = C_O = 1\text{ }\mu\text{F}$, unless otherwise specified.

Table 4. Electrical characteristics

Symbol	Parameter	Test conditions	Min.	Typ.	Max.	Unit
V_I	Operating input voltage	$I_O = 2\text{ A}$ (Flat-16) or 3 A (SMD.5 & TO-257)			12	V
V_O	Output voltage accuracy	$V_I = V_O + 2.5\text{ V}$, $I_O = 5\text{ mA}$	-2		2	%
I_{SHORT}	Output current limit ⁽¹⁾	Adjustable by mask/external resistor		4.5		A
V_O	Operating output voltage	$I_O = 2\text{ A}$, 2.5 V output voltage	2.45		2.55	V
V_O	Operating output voltage	$I_O = 2\text{ A}$, 3.3 V output voltage	3.23		3.37	V
V_O	Operating output voltage	$I_O = 2\text{ A}$, 5.0 V output voltage	4.9		5.1	V
$\Delta V_O / \Delta V_I$	Line regulation	$V_I = V_O + 2.5\text{ V}$ to 12 V, $I_O = 5\text{ mA}$ (+25°C)			0.3	%
		$V_I = V_O + 2.5\text{ V}$ to 12 V, $I_O = 5\text{ mA}$ (-55°C)			0.4	%
		$V_I = V_O + 2.5\text{ V}$ to 12 V, $I_O = 5\text{ mA}$ (+125°C)			0.4	%
$\Delta V_O / \Delta V_O$	Load regulation	$V_I = V_O + 2.5\text{ V}$, $I_O = 5\text{ mA}$ to 400 mA (+25°C)			0.2	%
		$V_I = V_O + 2.5\text{ V}$, $I_O = 5\text{ mA}$ to 400 mA (-55°C)			0.3	%
		$V_I = V_O + 2.5\text{ V}$, $I_O = 5\text{ mA}$ to 400 mA (+125°C)			0.3	%
		$V_I = V_O + 2.5\text{ V}$, $I_O = 5\text{ mA}$ to 1A (+25°C)			0.3	%
		$V_I = V_O + 2.5\text{ V}$, $I_O = 5\text{ mA}$ to 1A (-55°C)			0.4	%
		$V_I = V_O + 2.5\text{ V}$, $I_O = 5\text{ mA}$ to 1A (+125°C)			0.4	%
Z_{OUT}	Output impedance	$I_O = 100\text{ mA DC}$ and 20 mA rms		100		mΩ
I_q	Quiescent current	$V_I = V_O + 2.5\text{ V}$, $I_O = 30\text{ mA}$, on mode			8	mA
		$V_I = V_O + 2.5\text{ V}$, $I_O = 300\text{ mA}$, on mode			25	
		$V_I = V_O + 2.5\text{ V}$, $I_O = 1\text{ A}$, on mode			60	
		$V_I = V_O + 2.5\text{ V}$, $I_O = 3\text{ A}$, on mode (only for SMD.5 and TO-257)			150	
		$V_I = V_O + 2\text{ V}$, $V_{\text{INH}} = 2.4\text{ V}$, off mode			1	
I_q	Quiescent current	$V_I = V_O + 2.5\text{ V}$, $I_O = 1\text{ A}$, $T_J = +125\text{ °C}$, on mode			40	mA
		$V_I = V_O + 2.5\text{ V}$, $I_O = 1\text{ A}$, $T_J = -55\text{ °C}$, on mode			100	

Table 4. Electrical characteristics (continued)

Symbol	Parameter	Test conditions	Min.	Typ.	Max.	Unit
V _d	Dropout voltage	I _O = 400mA, T _J = -55°C		300	400	mV
		I _O = 400mA, T _J = +25°C		350	450	
		I _O = 400mA, T _J = +125°C		450	550	
		I _O = 1A, T _J = -55°C			550	
		I _O = 1A, T _J = +25°C			650	
		I _O = 1A, T _J = +125°C			800	
		I _O = 2A, T _J = +25°C		750		
		I _O = 2A, T _J = +125°C		950		
V _{INH(ON)}	Inhibit voltage	I _O = 5mA, T _J = -55 to 125°C			0.8	V
V _{INH(OFF)}	Inhibit voltage	I _O = 5mA, T _J = -55 to 125°C	2.4			V
SVR	Supply voltage rejection (1)	V _I = V _O +2.5V ± 1V, I _O = 5mA	f = 120Hz	60	70	dB
			f = 33kHz	30	40	
I _{SH}	Shutdown input current	V _{INH} = 5 V		15		µA
V _{OCM}	OCM pin voltage	Sinked I _{OCM} = 24 mA active low		0.38		V
t _{PLH} t _{PHL}	Inhibit propagation delay (1)	V _I = V _O +2.5V, V _{INH} = 2.4 V, I _O = 400 mA	on-off		20	µs
			off-on		100	µs
eN	Output noise voltage (1)	B= 10Hz to 100kHz, I _O = 5mA to 2A		40		µVrms

1. This value is guaranteed by design. For each application it's strongly recommended to comply with the maximum current limit of the package used.

Figure 4. Application diagram for remote sensing operation

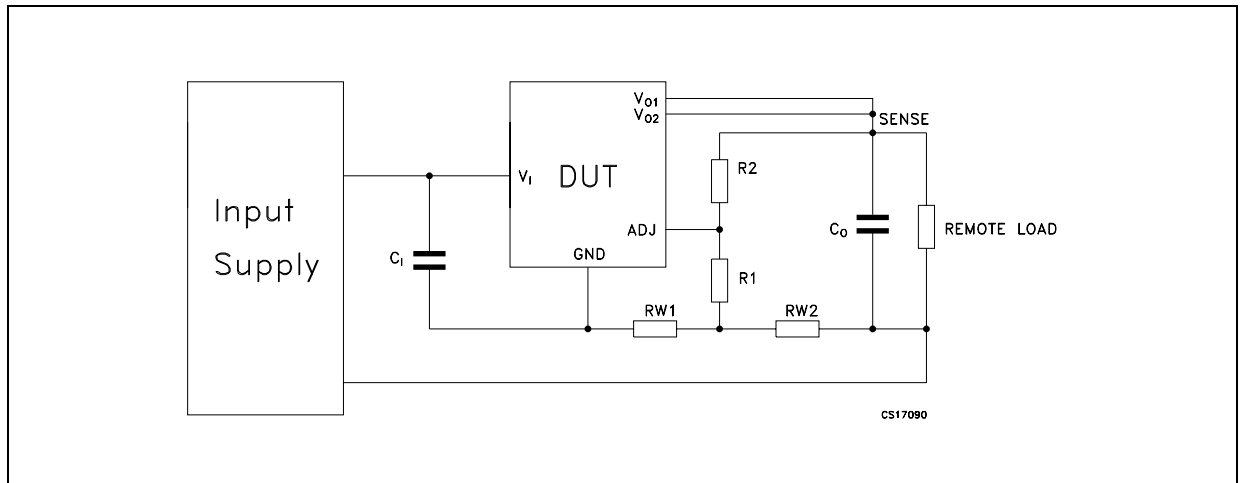

5 Device description

The RHFL4913 fixed voltage contains a PNP type power element controlled by a signal resulting from amplified comparison between the internal temperature compensated band-gap cell and the fraction of the desired output voltage value. This fractional value is obtained from an internal-to-die resistor divider bridge set by STMicroelectronics. The device is protected by several functional blocks.

5.1 Low pin count package limitations

Some functions (INHIBIT, OCM, SENSE) are not available due to lack of pins. Corresponding die pads are by default connected inside silicon.

5.2 SENSE pin

The load voltage is applied by a Kelvin line connected to SENSE pin: Voltage feed-back comes from the internal divider resistor bridge. Therefore possible output voltages are set by manufacturer mask metal options. SENSE pin is not available in 3pin packages.

5.3 Inhibit ON-OFF control

By setting INHIBIT pin TTL-high, the device switches off the output current and voltage. The device is ON when INHIBIT pin is set low. Since INHIBIT pin is internally pulled down, it can be left floating in case inhibit function is not utilized. INHIBIT pin is not available in 3pin packages.

5.4 Overtemperature protection

A temperature detector internally monitors the power element junction temperature. The device goes OFF at approx. 175 °C, returning to ON mode when back to approx. 40 °C. It is worth noting that when the internal temperature detector reaches 175 °C, the active power element can be at 225 °C: device reliability cannot be granted in case of extensive operation under these conditions.

5.5 Overcurrent protection

I_{SC} pin. An internal non-fold back short-circuit limitation is set with $I_{SHORT} > 3.8$ A (V_O is 0 V). This value can be reduced by an external resistor connected between I_{SC} pin and V_1 pin, with a typical value range of 25 k Ω to 200 k Ω . This adjustment feature is not available in 3 pin packages. To keep excellent V_O regulation, it is necessary to set I_{SHORT} 1.6 times greater than the maximum desired application I_O . When I_O reaches $I_{SHORT} - 300$ mA, the current limiter overrules regulation and V_O starts to drop and the OCM flag is risen. When no current limitation adjustment is required, I_{SC} pin must be left unbiased (as it is in 3 pin packages).

5.6 OCM pin

Goes low when current limiter starts to be active, otherwise $V_{OCM} = V_I$. It is bufferized and can sink 10 mA. OCM pin is internally pulled-up by a 5 k Ω resistor. Not available in 3 pin packages.

5.7 Alternate to

RHFL4913 fixed (& custom) voltages replace all 3-terminal industry devices, providing essential benefits

- Lower drop-out
- High radiation performance
- Better SVR
- Saving the high stability external setting resistors.

6 Application information

The RHFL4913 fixed voltage is functional as soon as $V_I - V_O$ voltage difference is slightly above the power element saturation voltage. A minimum 0.5 mA I_O ensures perfect “no-load” regulation.

All available V_I pins must always be externally interconnected, same thing for all available V_O pins, otherwise device stability and reliability cannot be granted. All NC pins can be connected to ground. The INHIBIT function switches off the output current in an electronic way, that is very quickly. According to Lenz’s Law, external circuitry reacts with $-Ldi/dt$ terms which can be of high amplitude in case some series-inductance exists. The effect would be a large transient voltage developed on both device terminals. It is necessary to protect the device with Schottky diodes preventing negative voltage excursions. In the worst case, a 14 V Zener diode shall protect the device input.

The device has been designed for high stability and low drop out operation: minimum 1 μ F input and output tantalum capacitors are therefore mandatory. Capacitor ESR range is from 0.01 Ω to over 20 Ω . Such range turns out to be useful when ESR increases at low temperature. When large transient currents are expected, larger value capacitors are necessary.

In case of high current operation with expected short-circuit events, caution must be considered relatively to capacitors. They must be connected as close as possible to device terminals. As some tantalum capacitors may permanently fail when submitted to high charge-up surge currents, it is recommended to decouple them with 470 nF polyester capacitors.

Being RHFL4913 fixed voltage manufactured with very high speed bipolar technology (6 GHz f_T transistors), the PCB lay-out must be performed with extreme care, very low inductance, low mutually coupling lines, otherwise high frequency parasitic signals may be picked-up by the device resulting into self-oscillation. User’s benefit is a SVR performance extended to far higher frequencies.

6.1 Remote sensing operation

In case the load is located far from the regulator, it is recommended to comply with the scheme below. To obtain the best regulation, it is in addition essential to care about:

- The wire connecting R2 to the load end must not be crossed by the load current (Kelvin sense).

The noise captured by the wires between the load and the chip could bring a noisy output voltage. In case this happens, it is recommended that shielded cables are used for these connections. The external wrap must be used for connecting the ground of the chip with the load ground. It is also recommended to place 1 μ F tantalum capacitors between output and ground close to the device and another next to the load.

7 Notes about Flat-16 package

The bottom of package is metallized to allow user to directly solder the voltage regulator to PCB, no heat sink needed, in order to optimize heat removal performance.

7.1 Radiation performances

The RHFL4913F has been tested against: 300krad TID ELDERS in accordance with Mil-1019.6, bipolar section: post radiation parameters are within datasheet pre-rad limits. Submitted to 200MeV Iodine ions of 60.4MeV/cm²/mg LET up to 1exp(+7) ions / cm², no SEL event has been detected.

7.2 Die information

RHFL4913 fixed is also available in die form. Space dice are electrically tested by STMicroelectronics in such a way that, when mounted in proper thermal and electrical substrate, they provide full compliance with equivalent packaged product.

- Max die dimensions: 2.794 mm by 3.861 mm or 110 mils by 152 mils
- Die thickness: 357 μm +/- 50 μm
- Pad size: 184 μm by 184 μm
- Metallization: Aluminum 4% silicon alloy
- Die backside: Bare silicon
- Die backside potential: Ground

Figure 5. Die size

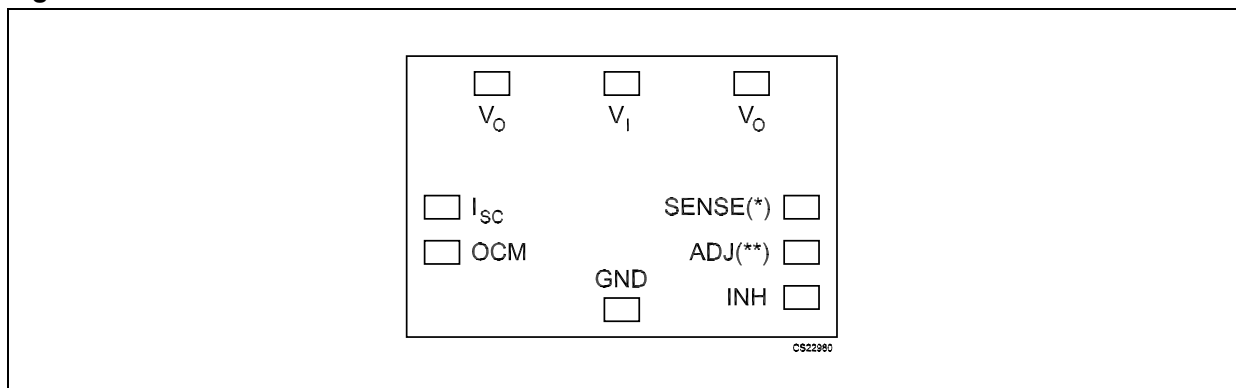

(*) Die SENSE pad is active in RHFL4913 fixed die. It shall not be left unbonded. It should be bonded to V_O pin.

(**) Die adjust pad is available in the die lay-out but is not electrically connected to the IC. It shall be left unconnected during hybrid bonding.

8 Package mechanical data

In order to meet environmental requirements, ST offers these devices in different grades of ECOPACK[®] packages, depending on their level of environmental compliance. ECOPACK[®] specifications, grade definitions and product status are available at: www.st.com. ECOPACK[®] is an ST trademark.

Flat-16 (MIL-STD-1835) mechanical data

Dim.	mm.			inch.		
	Min.	Typ.	Max.	Min.	Typ.	Max.
A	2.16		2.72	0.085		0.107
b		0.43			0.017	
c		0.13			0.005	
D		9.91			0.390	
E		6.91			0.272	
E2		4.32			0.170	
E3	0.76			0.030		
e		1.27			0.050	
L		6.72			0.265	
Q	0.66		1.14	0.026		0.045
S1	0.13			0.005		

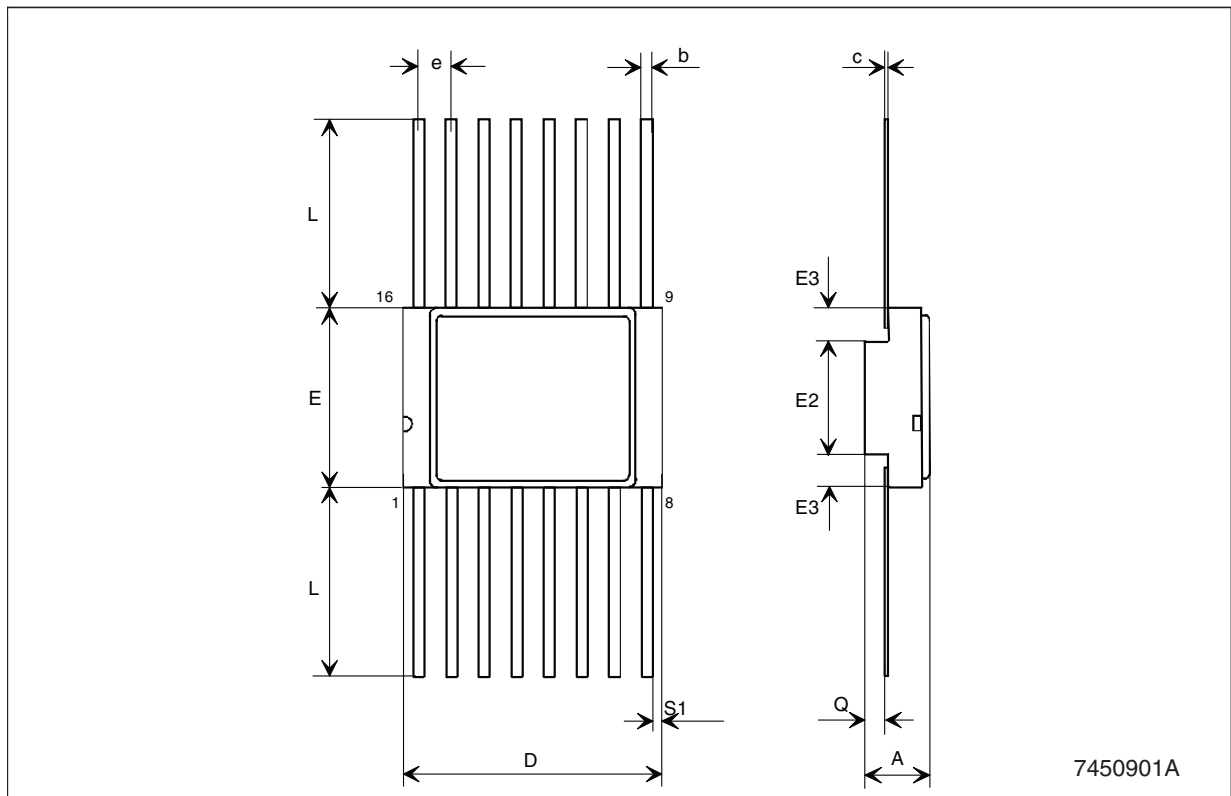

SMD.5 mechanical data

Dim.	mm.			inch.		
	Min.	Typ.	Max.	Min.	Typ.	Max.
A	2.84	3.00	3.15	0.112	0.118	0.124
A1	0.25	0.38	0.51	0.010	0.015	0.020
b	7.13	7.26	7.39	0.281	0.286	0.291
b1	5.58	5.72	5.84	0.220	0.225	0.230
b2	2.28	2.41	2.54	0.090	0.095	0.100
b3	2.92	3.05	3.18	0.115	0.120	0.125
D	10.03	10.16	10.28	0.395	0.400	0.405
D1	0.76			0.030		
E	7.39	7.52	7.64	0.291	0.296	0.301
e		1.91			0.075	

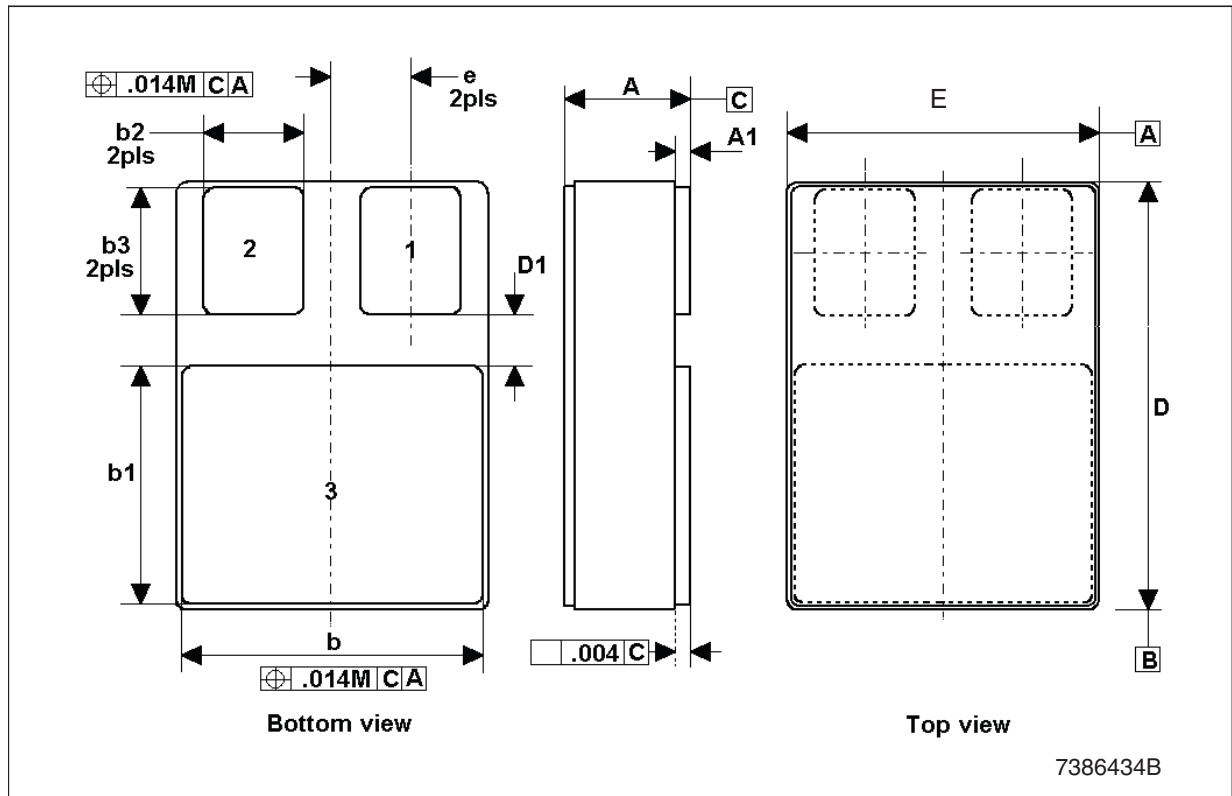

TO-257 mechanical data

Dim.	mm.			inch.		
	Min.	Typ.	Max.	Min.	Typ.	Max.
A		10.54			0.415	
B		10.54			0.415	
C		16.64			0.655	
D	4.7		5.33	0.185		0.210
E		1.02			0.40	
F	3.56	3.68	3.81	0.140	0.145	0.150
G		13.51			0.532	
H		5.26			0.207	
I		0.76			0.030	
J		3.05			0.120	
K		2.54			0.100	
L	15.2		16.5	0.598		0.650
M		2.29			0.090	
N			0.71			0.028
R		1.65			0.065	

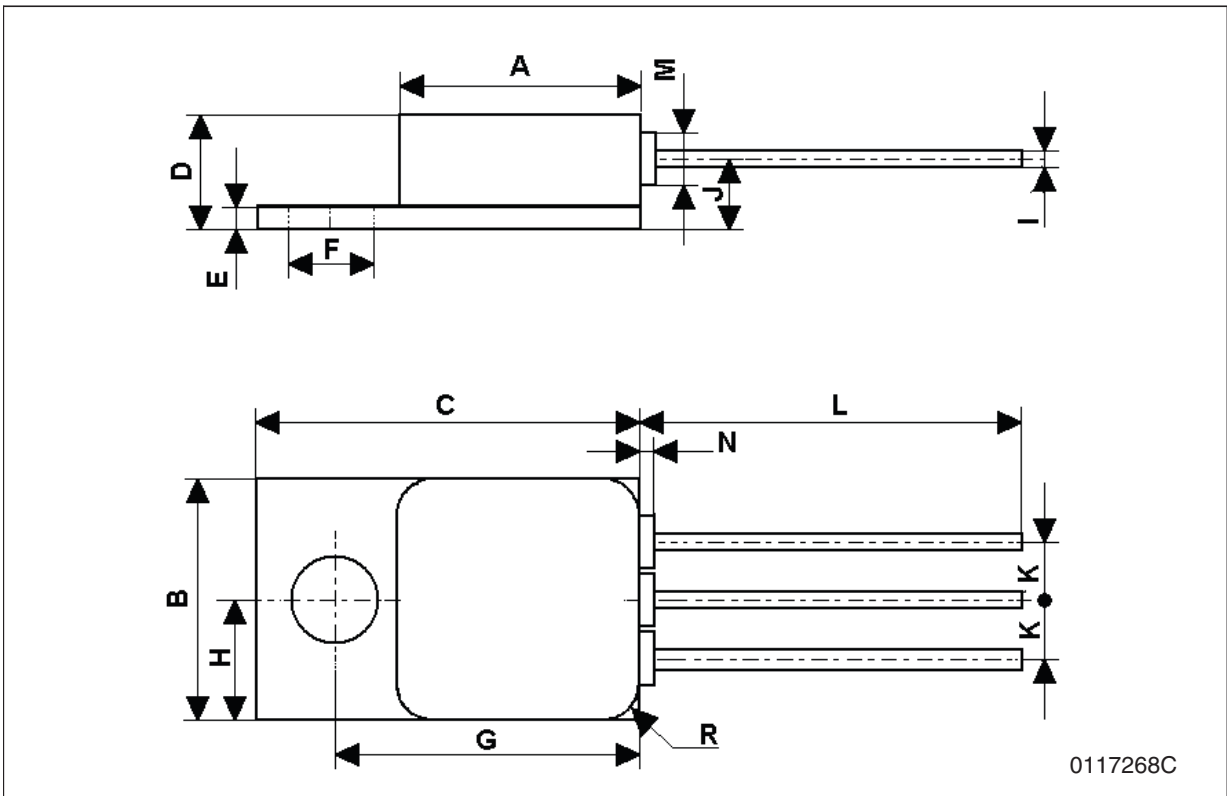

9 Ordering information

Table 5. Order codes

DIE	Flat-16	SMD.5	TO-257	Terminal finish	Out. volt.	Q.ty level
	RHFL4913KP25-01V	RHFL4913S25-03V	RHFL4913ESY2505V	GOLD	2.5 V	QML-V
	RHFL4913KP25-02V	RHFL4913S25-04V	RHFL4913ESY2506V	SOLDER	2.5 V	QML-V
	RHFL4913KP251	RHFL4913S251	RHFL4913ESY251	GOLD	2.5 V	EM1
	RHFL4913KP252	RHFL4913S252	RHFL4913ESY252	GOLD	2.5 V	EM1=EM 2+48h B.I.
L491325DIE2V				NA	2.5 V	QML-V
L491325DIE2S				NA	2.5 V	EM1
	RHFL4913KP33-01V	RHFL4913S33-03V	RHFL4913ESY3305V	GOLD	3.3 V	QML-V
	RHFL4913KP33-02V	RHFL4913S33-04V	RHFL4913ESY3306V	SOLDER	3.3 V	QML-V
	RHFL4913KP331	RHFL4913S331	RHFL4913ESY331	GOLD	3.3 V	EM1
	RHFL4913KP332	RHFL4913S332	RHFL4913ESY332	GOLD	3.3 V	EM1=EM 2+48h B.I.
L491333DIE2V				NA	3.3 V	QML-V
L491333DIE2S				NA	3.3 V	EM1
	RHFL4913KP50-01V	RHFL4913S50-03V	RHFL4913ESY5005V	GOLD	5.0 V	QML-V
	RHFL4913KP50-02V	RHFL4913S50-04V	RHFL4913ESY5006V	SOLDER	5.0 V	QML-V
	RHFL4913KP501	RHFL4913S501	RHFL4913ESY501	GOLD	5.0 V	EM1
	RHFL4913KP502	RHFL4913S502	RHFL4913ESY502	GOLD	5.0 V	EM1=EM 2+48h B.I.
L491350DIE2V				NA	5.0 V	QML-V
L491350DIE2S				NA	5.0 V	EM1

Table 6. Part number - SMD equivalent

ST part number	SMD part number
RHFL4913KP25-01V	5962F0253401VXC
RHFL4913KP25-02V	5962F0253401VXA
RHFL4913KP33-01V	5962F0253501VXC
RHFL4913KP33-02V	5962F0253501VXA
RHFL4913KP50-01V	5962F0253601VXC
RHFL4913KP50-02V	5962F0253601VXA
RHFL4913S25-03V	5962F0253402VYC
RHFL4913S25-04V	5962F0253402VYA
RHFL4913S33-03V	5962F0253502VYC
RHFL4913S33-04V	5962F0253502VYA
RHFL4913S50-03V	5962F0253602VYC
RHFL4913S50-04V	5962F0253602VYA
RHFL4913ESY2505V	5962F0253402VZC
RHFL4913ESY2506V	5962F0253402VZA
RHFL4913ESY3305V	5962F0253502VZC
RHFL4913ESY3306V	5962F0253502VZA
RHFL4913ESY5005V	5962F0253602VZC
RHFL4913ESY5006V	5962F0253602VZA
L491325DIE2V	5962F0253402V9A
L491333DIE2V	5962F0253502V9A
L491350DIE2V	5962F0253602V9A

Note: 3 V version is available on request.

Table 7. Environmental characteristics

Parameter	Conditions	Value	Unit
Output voltage thermal drift	-55°C to +125°C	40	ppm/°C
Output voltage radiation drift	From 0 krad to 300 krad at 0.55 rad/s	8	ppm/krad
Output voltage radiation drift	From 0 krad to 300 krad, Mil Std 883E Method 1019.6	6	ppm/krad

10 Revision history

Table 8. Document revision history

Date	Revision	Changes
05-May-2004	4	Mistake in pin description SMD.5 on table 3.
28-Oct-2004	5	New order codes added - tables 4 and 5.
27-May-2005	6	The features, tables 4, 5 and the figures 1, 2 updated.
08-Jun-2005	7	Modified: P_D on table 1, the R_{thJC} for TO-257 on table 2 and the tables 6 and 7, added DIE information.
26-Aug-2008	8	Added new output 1.5 V, modified: Table 4 on page 6 , Table 5 on page 16 and Table 6 on page 17 .
02-Oct-2008	9	Modified: Features on page 1 , Application information on page 10 and SMD.5 mechanical data on page 14 .
20-Nov-2009	10	Modified: Table 5 on page 16 .
19-Oct-2010	11	Modified: Section 7 on page 11 .
08-Feb-2011	12	Added: note Table 1 on page 4 .
07-Dec-2011	13	Removed the note under Table 1 on page 4 and added footnotes 1 and 2.

Please Read Carefully:

Information in this document is provided solely in connection with ST products. STMicroelectronics NV and its subsidiaries ("ST") reserve the right to make changes, corrections, modifications or improvements, to this document, and the products and services described herein at any time, without notice.

All ST products are sold pursuant to ST's terms and conditions of sale.

Purchasers are solely responsible for the choice, selection and use of the ST products and services described herein, and ST assumes no liability whatsoever relating to the choice, selection or use of the ST products and services described herein.

No license, express or implied, by estoppel or otherwise, to any intellectual property rights is granted under this document. If any part of this document refers to any third party products or services it shall not be deemed a license grant by ST for the use of such third party products or services, or any intellectual property contained therein or considered as a warranty covering the use in any manner whatsoever of such third party products or services or any intellectual property contained therein.

UNLESS OTHERWISE SET FORTH IN ST'S TERMS AND CONDITIONS OF SALE ST DISCLAIMS ANY EXPRESS OR IMPLIED WARRANTY WITH RESPECT TO THE USE AND/OR SALE OF ST PRODUCTS INCLUDING WITHOUT LIMITATION IMPLIED WARRANTIES OF MERCHANTABILITY, FITNESS FOR A PARTICULAR PURPOSE (AND THEIR EQUIVALENTS UNDER THE LAWS OF ANY JURISDICTION), OR INFRINGEMENT OF ANY PATENT, COPYRIGHT OR OTHER INTELLECTUAL PROPERTY RIGHT.

UNLESS EXPRESSLY APPROVED IN WRITING BY TWO AUTHORIZED ST REPRESENTATIVES, ST PRODUCTS ARE NOT RECOMMENDED, AUTHORIZED OR WARRANTED FOR USE IN MILITARY, AIR CRAFT, SPACE, LIFE SAVING, OR LIFE SUSTAINING APPLICATIONS, NOR IN PRODUCTS OR SYSTEMS WHERE FAILURE OR MALFUNCTION MAY RESULT IN PERSONAL INJURY, DEATH, OR SEVERE PROPERTY OR ENVIRONMENTAL DAMAGE. ST PRODUCTS WHICH ARE NOT SPECIFIED AS "AUTOMOTIVE GRADE" MAY ONLY BE USED IN AUTOMOTIVE APPLICATIONS AT USER'S OWN RISK.

Resale of ST products with provisions different from the statements and/or technical features set forth in this document shall immediately void any warranty granted by ST for the ST product or service described herein and shall not create or extend in any manner whatsoever, any liability of ST.

ST and the ST logo are trademarks or registered trademarks of ST in various countries.

Information in this document supersedes and replaces all information previously supplied.

The ST logo is a registered trademark of STMicroelectronics. All other names are the property of their respective owners.

© 2011 STMicroelectronics - All rights reserved

STMicroelectronics group of companies

Australia - Belgium - Brazil - Canada - China - Czech Republic - Finland - France - Germany - Hong Kong - India - Israel - Italy - Japan - Malaysia - Malta - Morocco - Philippines - Singapore - Spain - Sweden - Switzerland - United Kingdom - United States of America

www.st.com