

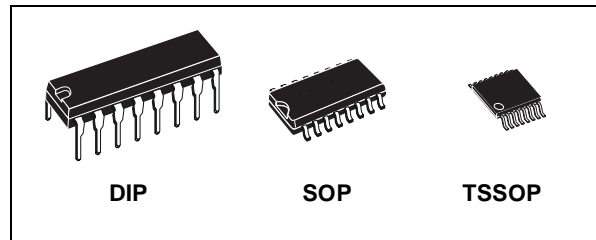

M74HC221

DUAL MONOSTABLE MULTIVIBRATOR

- HIGH SPEED :
 $t_{PD} = 24 \text{ ns (TYP.) at } V_{CC} = 6V$
- LOW POWER DISSIPATION:
 STAND BY STATE :
 $I_{CC} = 4\mu\text{A (MAX.) at } T_A = 25^\circ\text{C}$
 ACTIVE STATE :
 $I_{CC} = 700\mu\text{A (MAX.) at } V_{CC} = 5V$
- HIGH NOISE IMMUNITY:
 $V_{NIH} = V_{NIL} = 28 \% V_{CC} \text{ (MIN.)}$
- SYMMETRICAL OUTPUT IMPEDANCE:
 $|I_{OH}| = I_{OL} = 4\text{mA (MIN.)}$
- BALANCED PROPAGATION DELAYS:
 $t_{PLH} \cong t_{PHL}$
- WIDE OPERATING VOLTAGE RANGE:
 $V_{CC} \text{ (OPR)} = 2V \text{ to } 6V$
- WIDE OUTPUT PULSE WIDTH RANGE :
 $t_{WOUT} = 150 \text{ ns} \sim 60 \text{ s OVER AT } V_{CC} = 4.5 \text{ V}$
- PIN AND FUNCTION COMPATIBLE WITH
 74 SERIES 221



ORDER CODES

PACKAGE	TUBE	T & R
DIP	M74HC221B1R	
SOP	M74HC221M1R	M74HC221RM13TR
TSSOP		M74HC221TTR

DESCRIPTION

The M74HC221 is a high speed CMOS MONOSTABLE MULTIVIBRATOR fabricated with silicon gate C²MOS technology.

There are two trigger inputs, A INPUT (negative edge) and B INPUT (positive edge).

Triggering on the B input occurs at a particular voltage threshold and is not related to rise and fall time of the applied pulse. The device may also be trigger by using the CLR input (positive edge) because of the Schmitt-trigger input; after

triggering the output maintains the MONOSTABLE STATE for the time period determined by the external resistor Rx and capacitor Cx. Taking CLR low breaks this MONOSTABLE STATE. If the next trigger pulse occurs during the MONOSTABLE period it makes the MONOSTABLE period longer.

Limit for values of Cx and Rx :

Cx : NO LIMIT

Rx : $V_{CC} < 3.0V$ 5KΩ to 1MΩ

$V_{CC} \geq 3.0V$ 1KΩ to 1MΩ

K ≅ 0.7

All inputs are equipped with protection circuits against static discharge and transient excess voltage.

PIN CONNECTION AND IEC LOGIC SYMBOLS

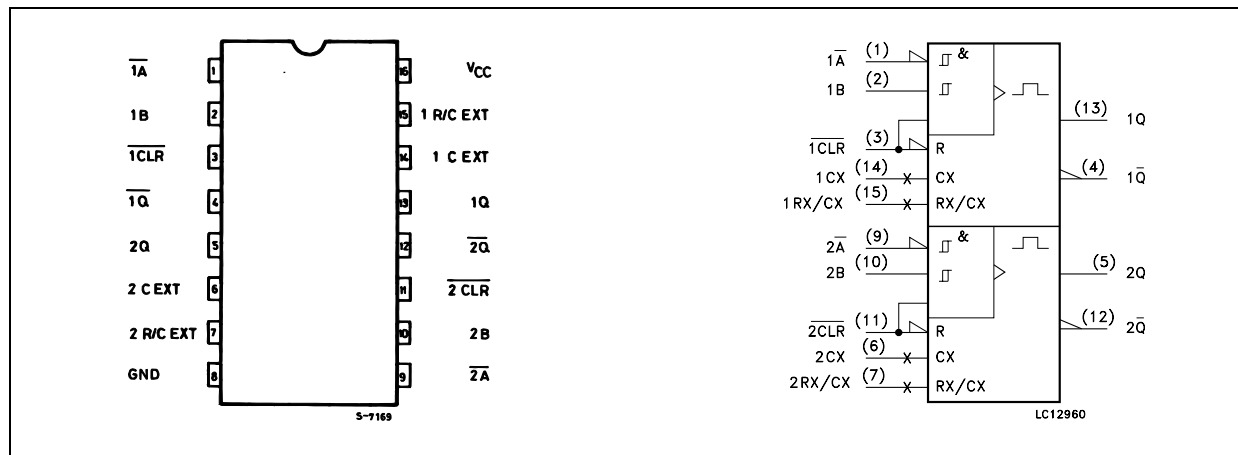

INPUT AND OUTPUT EQUIVALENT CIRCUIT

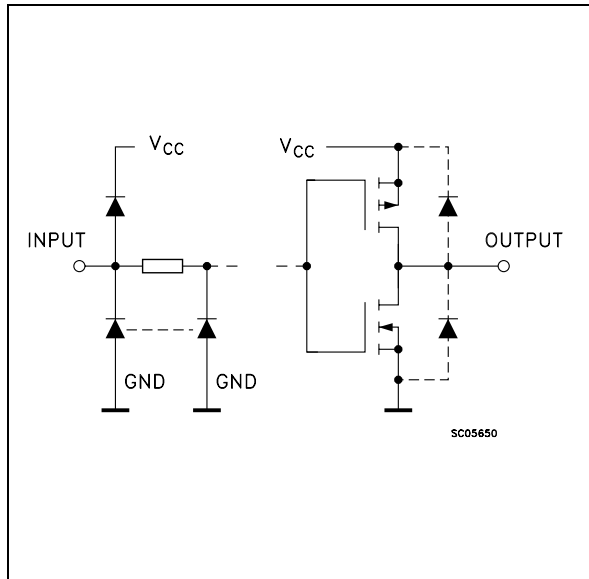

PIN DESCRIPTION

PIN No	SYMBOL	NAME AND FUNCTION
1,9	1 \bar{A} , 2 \bar{A}	Trigger Inputs (Negative Edge Triggered)
2, 10	1B, 2B	Trigger Inputs (Positive Edge Triggered)
3, 11	1 $\overline{\text{CLR}}$ 2 CLR	Direct Reset LOW and trigger Action at Positive Edge
4, 12	1Q, 2Q	Outputs (Active Low)
7	2R _X /C _X	External Resistor Capacitor Connection
13, 5	1Q, 2Q	Outputs (Active High)
14, 6	1C _X 2C _X	External Capacitor Connection
15	1R _X /C _X	External Resistor Capacitor Connection
8	GND	Ground (0V)
16	Vcc	Positive Supply Voltage

TRUTH TABLE

INPUTS			OUTPUTS		NOTE
\bar{A}	B	$\overline{\text{CLR}}$	Q	\bar{Q}	
	H	H			OUTPUT ENABLE
X	L	H	L(*)	H(*)	INHIBIT
H	X	H	L(*)	H(*)	INHIBIT
L		H			OUTPUT ENABLE
L	H				OUTPUT ENABLE
X	X	L	L	H	INHIBIT

X : Don't Care
 (*) : Except for monostable period

SYSTEM DIAGRAM

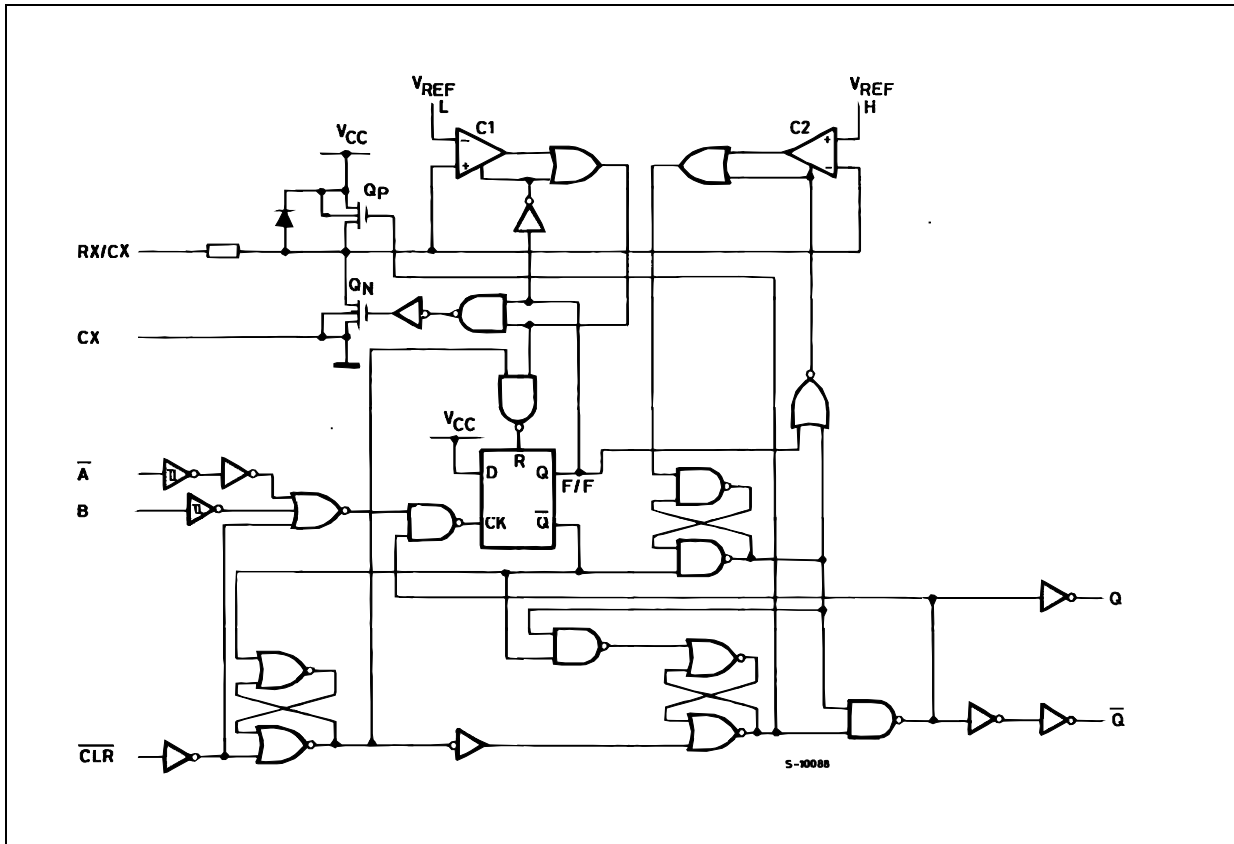

This logic diagram has not be used to estimate propagation delays

TIMING CHART

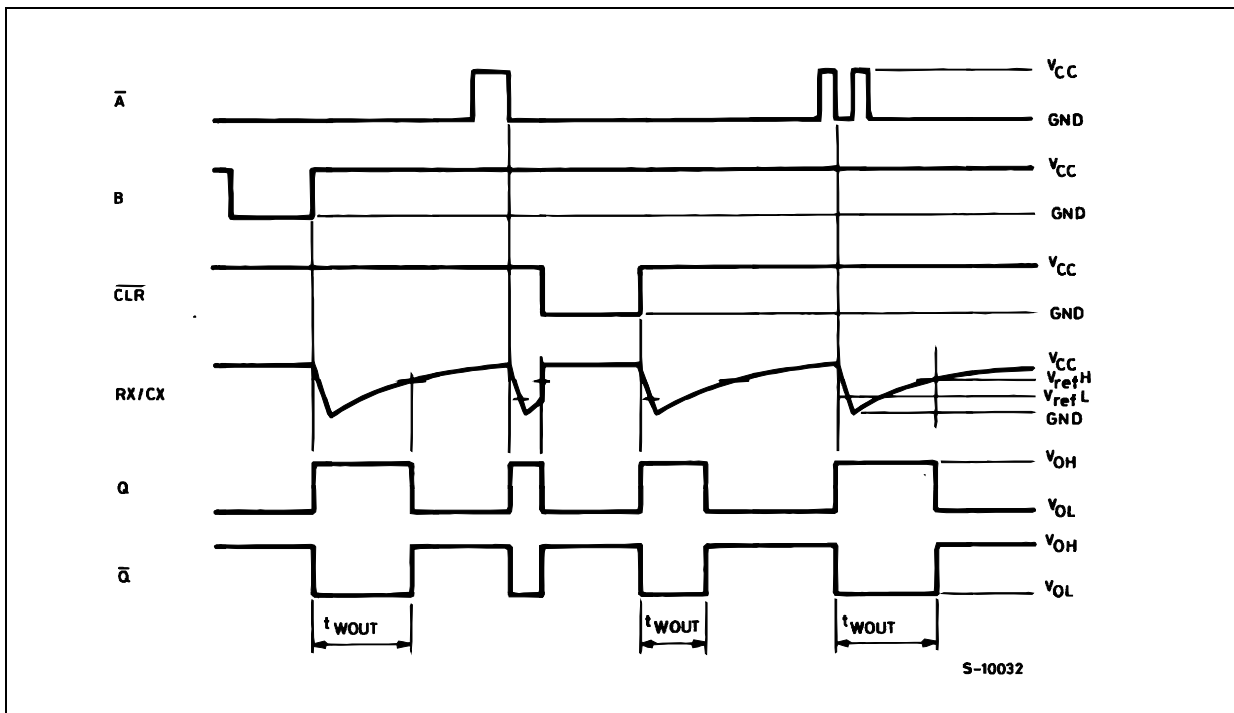

BLOCK DIAGRAM

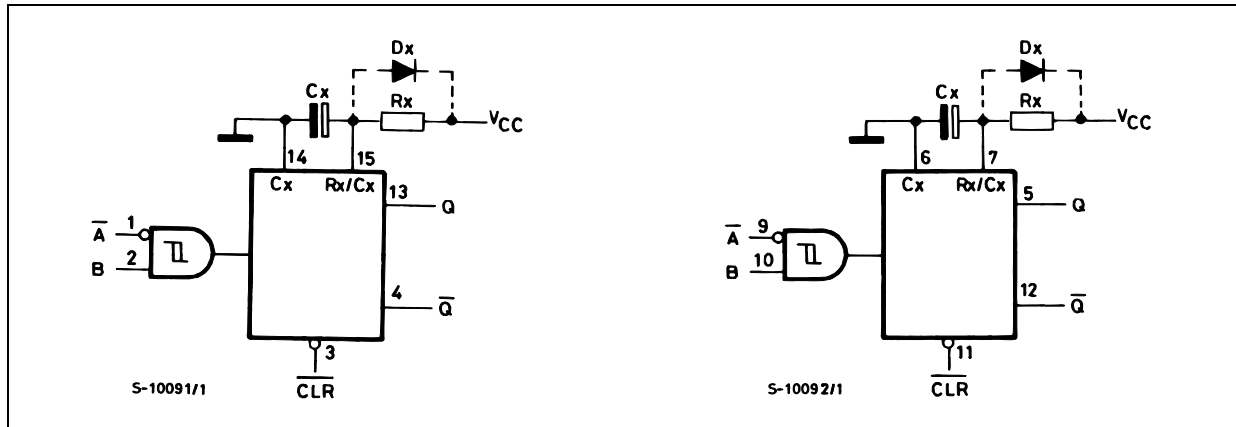

(1) Cx, Rx, Dx are external components.

(2) Dx is a clamping diode.

The external capacitor is charged to Vcc in the stand-by-state, i.e. no trigger. When the supply voltage is turned off Cx is discharged mainly through an internal parasitic diode (see figures). If Cx is sufficiently large and Vcc decreases rapidly, there will be some possibility of damaging the I.C. with a surge current or latch-up. If the voltage supply filter capacitor is large enough and Vcc decrease slowly, the surge current is automatically limited and damage to the I.C. is avoided. The maximum forward current of the parasitic diode is approximately 20 mA. In cases where Cx is large the time taken for the supply voltage to fall to 0.4 Vcc can be calculated as follows :

$$t_f \geq (V_{cc} - 0.7) \times C_x / 20\text{mA}$$

In cases where t_f is too short an external clamping diode is required to protect the I.C. from the surge current.

FUNCTIONAL DESCRIPTION

STAND-BY STATE

The external capacitor, Cx, is fully charged to Vcc in the stand-by state. Hence, before triggering, transistor Qp and Qn (connected to the Rx/Cx node) are both turned-off. The two comparators that control the timing and the two reference voltage sources stop operating. The total supply current is therefore only leakage current.

TRIGGER OPERATION

Triggering occurs when :

- 1 st) A is "LOW" and B has a falling edge;
- 2 nd) B is "HIGH" and A has a rising edge;
- 3 rd) A is "LOW" and B is HIGH and C1 has a rising edge;

After the multivibrator has been retriggered comparator C1 and C2 start operating and Qn is turned on. Cx then discharges through Qn. The voltage at the node R/C external falls.

When it reaches V_{REFL} the output of comparator C1 becomes low. This in turn reset the flip-flop and Qn is turned off.

At this point C1 stops functioning but C2 continues to operate.

The voltage at R/C external begins to rise with a time constant set by the external components Rx, Cx.

Triggering the multivibrator causes Q to go high after internal delay due to the flip-flop and the gate. Q remains high until the voltage at R/C external rises again to V_{REFH} . At this point C2 output goes low and O goes low. C2 stop operating. That means that after triggering when the voltage R/C external returns to V_{REFH} the multivibrator has returned to its MONOSTABLE STATE. In the case where Rx · Cx are large enough and the discharge time of the capacitor and the delay time in the I.C. can be ignored, the width of the output pulse t_w (out) is as follows :

$$t_w(\text{OUT}) = 0.70 C_x \cdot R_x$$

RESET OPERATION

CL is normally high. If CL is low, the trigger is not effective because Q output goes low and trigger control flip-flop is reset.

Also transistor Op is turned on and Cx is charged quickly to Vcc. This means if CL input goes low the IC becomes waiting state both in operating and non operating state.

ABSOLUTE MAXIMUM RATINGS

Symbol	Parameter	Value	Unit
V_{CC}	Supply Voltage	-0.5 to +7	V
V_I	DC Input Voltage	-0.5 to $V_{CC} + 0.5$	V
V_O	DC Output Voltage	-0.5 to $V_{CC} + 0.5$	V
I_{IK}	DC Input Diode Current	± 20	mA
I_{OK}	DC Output Diode Current	± 20	mA
I_O	DC Output Current	± 25	mA
I_{CC} or I_{GND}	DC V_{CC} or Ground Current	± 50	mA
P_D	Power Dissipation	500(*)	mW
T_{stg}	Storage Temperature	-65 to +150	°C
T_L	Lead Temperature (10 sec)	300	°C

Absolute Maximum Ratings are those values beyond which damage to the device may occur. Functional operation under these conditions is not implied

(*) 500mW at 65 °C; derate to 300mW by 10mW/°C from 65°C to 85°C

RECOMMENDED OPERATING CONDITIONS

Symbol	Parameter	Value	Unit	
V_{CC}	Supply Voltage	2 to 6	V	
V_I	Input Voltage	0 to V_{CC}	V	
V_O	Output Voltage	0 to V_{CC}	V	
T_{op}	Operating Temperature	-55 to 125	°C	
t_r, t_f	Input Rise and Fall Time (CLR and A only)	$V_{CC} = 2.0V$	0 to 1000	ns
		$V_{CC} = 4.5V$	0 to 500	ns
		$V_{CC} = 6.0V$	0 to 400	ns
C_x	External Capacitor	> 100 (*)	pF	
R_x	External Resistor	$V_{CC} < 3V$	5K to 1M (*)	Ω
		$V_{CC} \geq 3V$	1K to 1M (*)	

(*) The Maximum allowable values of C_x and R_x are a function of leakage of capacitor C_x , the leakage of device and leakage due to the board layout and surface resistance. Susceptibility to externally induced noise may occur for $R_x > 1M\Omega$

DC SPECIFICATIONS

Symbol	Parameter	Test Condition		Value						Unit	
		V _{CC} (V)		T _A = 25°C			-40 to 85°C		-55 to 125°C		
				Min.	Typ.	Max.	Min.	Max.	Min.		Max.
V _{IH}	High Level Input Voltage	2.0		1.5			1.5		1.5		V
		4.5		3.15			3.15		3.15		
		6.0		4.2			4.2		4.2		
V _{IL}	Low Level Input Voltage	2.0				0.5		0.5		0.5	V
		4.5				1.35		1.35		1.35	
		6.0				1.8		1.8		1.8	
V _{OH}	High Level Output Voltage (Q, Q Output)	2.0	I _O =-20 μA	1.9	2.0		1.9		1.9		V
		4.5	I _O =-20 μA	4.4	4.5		4.4		4.4		
		6.0	I _O =-20 μA	5.9	6.0		5.9		5.9		
		4.5	I _O =-4.0 mA	4.18	4.31		4.13		4.10		
		6.0	I _O =-5.2 mA	5.68	5.8		5.63		5.60		
V _{OL}	Low Level Output Voltage (Q, Q Output)	2.0	I _O =20 μA		0.0	0.1		0.1		0.1	V
		4.5	I _O =20 μA		0.0	0.1		0.1		0.1	
		6.0	I _O =20 μA		0.0	0.1		0.1		0.1	
		4.5	I _O =4.0 mA		0.17	0.26		0.33		0.40	
		6.0	I _O =5.2 mA		0.18	0.26		0.33		0.40	
I _I	Input Leakage Current	6.0	V _I = V _{CC} or GND			± 0.1		± 1		± 1	μA
I _I	R/C Terminal Off State Current	6.0	V _I = V _{CC} or GND			± 0.5		± 5		± 10	μA
I _{CC}	Quiescent Supply Current	6.0	V _I = V _{CC} or GND			4		40		80	μA
I _{CC} '	Active State Supply Current (1)	2.0	V _I = V _{CC} or GND		45	250		260		350	μA
		4.5	Pin 7 or 15		400	530		650		850	μA
		6.0	V _{IN} = V _{CC} /2		0.7	1		1.3		1.7	mA

(1) : Per Circuit

AC ELECTRICAL CHARACTERISTICS ($C_L = 50 \text{ pF}$, Input $t_r = t_f = 6 \text{ ns}$)

Symbol	Parameter	Test Condition		Value						Unit	
		V_{CC} (V)		$T_A = 25^\circ\text{C}$			$-40 \text{ to } 85^\circ\text{C}$		$-55 \text{ to } 125^\circ\text{C}$		
				Min.	Typ.	Max.	Min.	Max.	Min.		Max.
t_{TLH} t_{THL}	Output Transition Time	2.0			30	75		95		110	ns
		4.5			8	15		19		22	
		6.0			7	13		16		19	
t_{PLH} t_{PHL}	Propagation Delay Time (\bar{A} , B - Q, \bar{Q})	2.0			102	210		265		315	ns
		4.5			30	42		53		63	
		6.0			24	36		45		54	
t_{PLH} t_{PHL}	Propagation Delay Time (CLR TRIGGER - Q, \bar{Q})	2.0			102	235		295		355	ns
		4.5			30	47		59		71	
		6.0			24	40		50		60	
t_{PLH} t_{PHL}	Propagation Delay Time ($\bar{\text{CLR}}$ - Q, \bar{Q})	2.0			67	160		200		240	ns
		4.5			20	32		40		48	
		6.0			16	27		34		41	
t_{WOUT}	Output Pulse Width	2.0	$C_x = 100 \text{ pF}$ $R_x = 10\text{K}\Omega$		1.5						μs
		4.5			1.3						
		6.0			1.2						
		2.0	$C_x = 0.1\mu\text{F}$ $R_x = 100\text{K}\Omega$		7.0						ms
		4.5			6.9						
		6.0			6.9						
Δt_{WOUT}	Output Pulse Width Error Between Circuits in Same Package				± 1						%
$t_{W(H)}$ $t_{W(L)}$	Minimum Pulse Width	2.0				75		95		110	ns
		4.5				15		19		22	
		6.0				13		16		20	
$t_{W(L)}$	Minimum Pulse Width	2.0				75		95		110	ns
		4.5				15		19		22	
		6.0				13		16		20	

CAPACITIVE CHARACTERISTICS

Symbol	Parameter	Test Condition		Value						Unit	
		V_{CC} (V)		$T_A = 25^\circ\text{C}$			$-40 \text{ to } 85^\circ\text{C}$		$-55 \text{ to } 125^\circ\text{C}$		
				Min.	Typ.	Max.	Min.	Max.	Min.		Max.
C_{IN}	Input Capacitance	5.0			5	10		10		10	pF
C_{PD}	Power Dissipation Capacitance (note 1)	5.0			174						pF

1) C_{PD} is defined as the value of the IC's internal equivalent capacitance which is calculated from the operating current consumption without load. (Refer to Test Circuit). Average operating current can be obtained by the following equation. $I_{CC(opr)} = C_{PD} \times V_{CC} \times f_{IN} + I_{CC}' \text{ Duty}/100 + I_{CC}/2$ (per monostable) (I_{CC}' : Active Supply current) (Duty: %)

TEST CIRCUIT

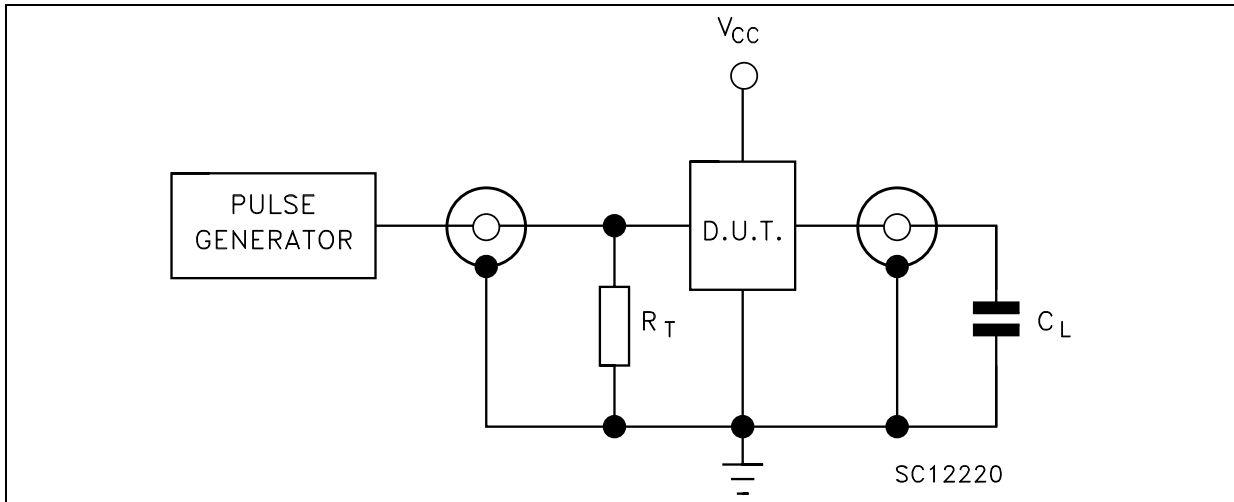

$C_L = 50\text{pF}$ or equivalent (includes jig and probe capacitance)
 $R_T = Z_{OUT}$ of pulse generator (typically 50Ω)

WAVEFORM 1: MINIMUM PULSE WIDTH (\bar{A} , B), OUTPUT PULSE WIDTH, PROPAGATION DELAY TIME ($f=1\text{MHz}$; 50% duty cycle)

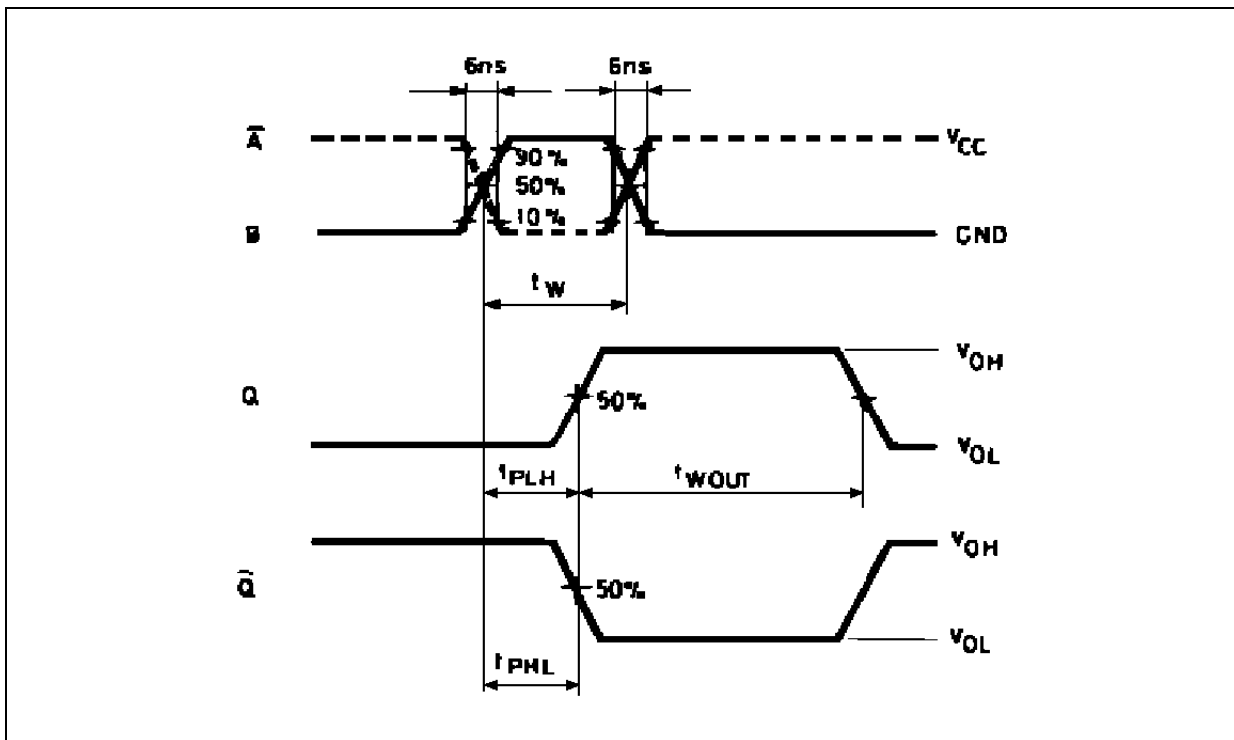

WAVEFORM 2 : MIIMUM PULSE WIDTH ($\overline{\text{CLR}}$), PROPAGATION DELAY TIME ($f=1\text{MHz}$; 50% duty cycle)

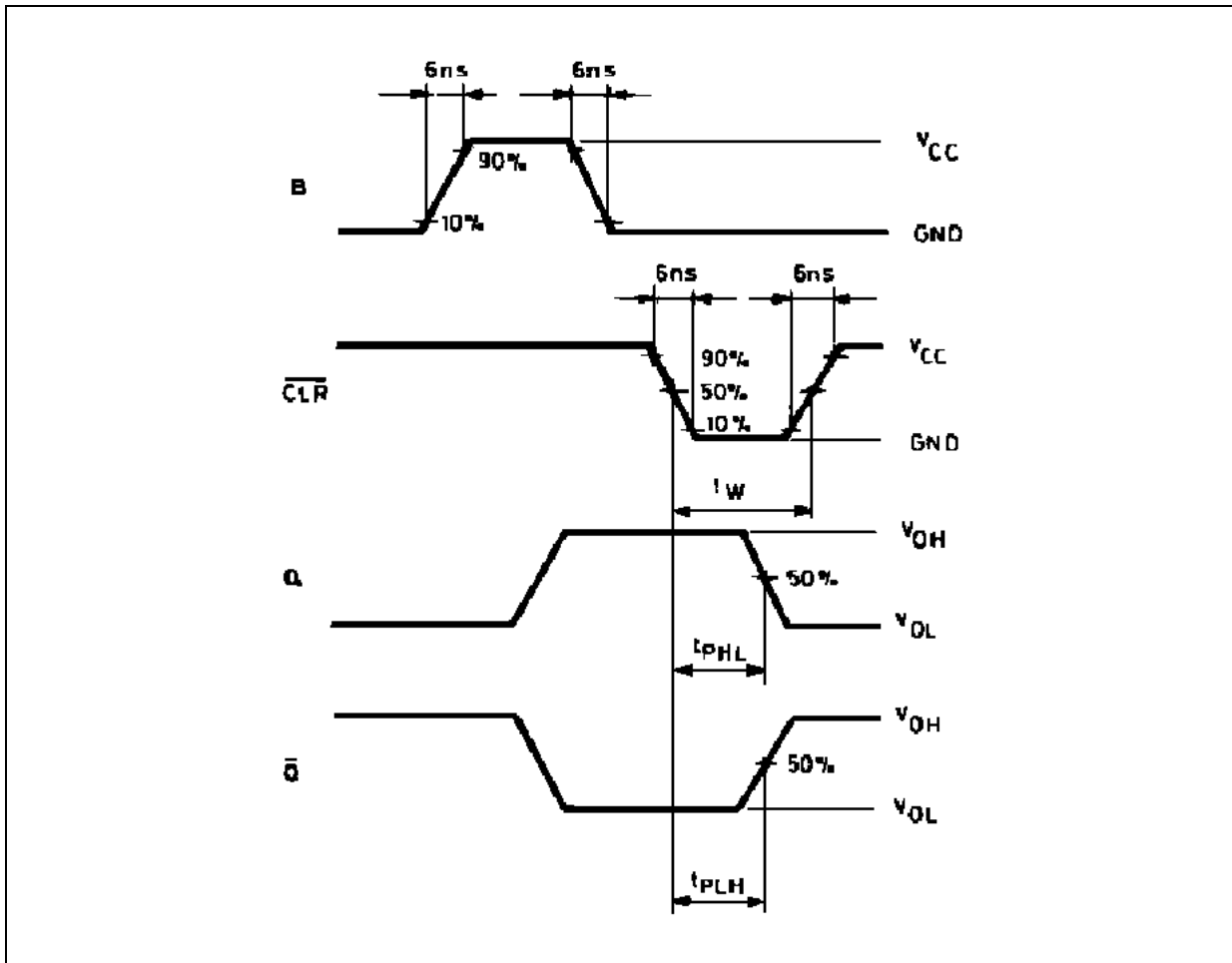

WAVEFORM 3 : REMOVAL TIME ($\overline{\text{CLR}}$ TO A-B) (f=1MHz; 50% duty cycle)

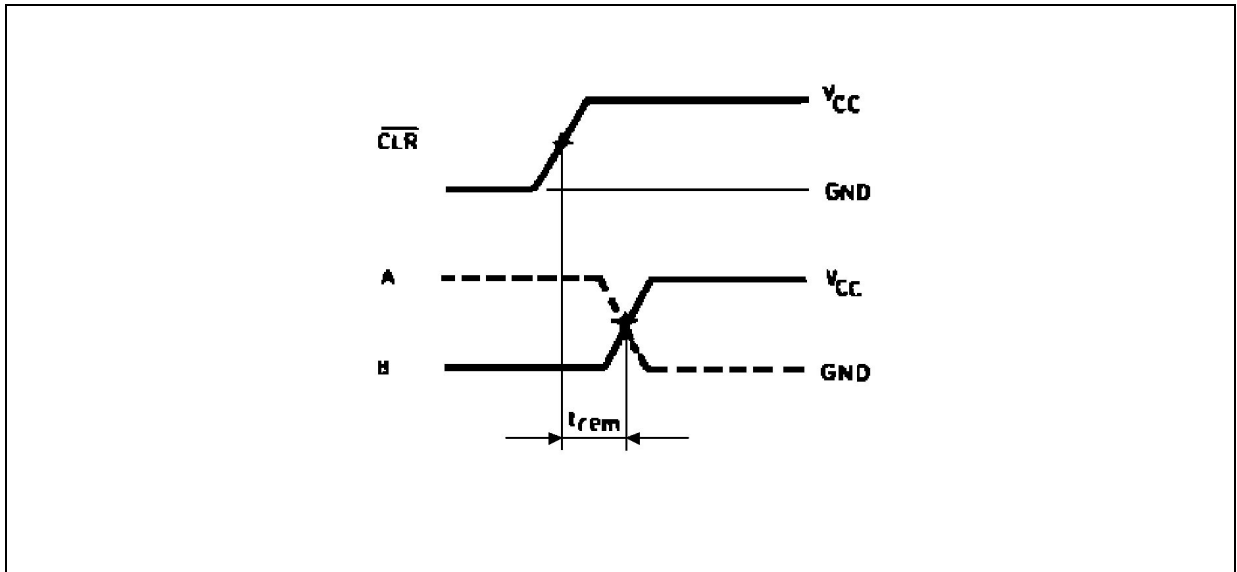

WAVEFORM 4 : REMOVAL TIME ($\overline{\text{CLR}}$ TO $\overline{\text{A}}$ -B) (f=1MHz; 50% duty cycle)

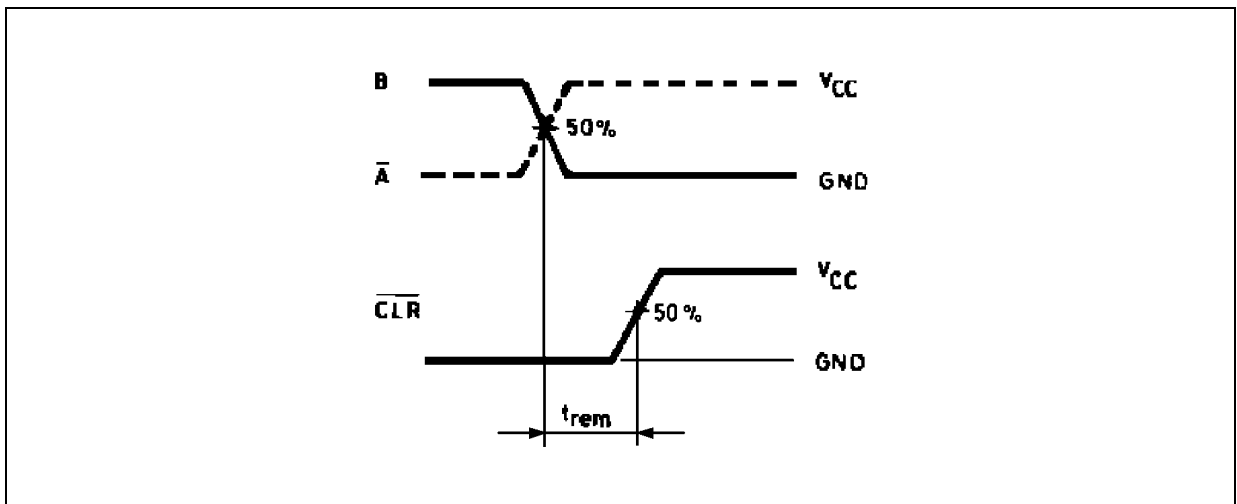

Plastic DIP-16 (0.25) MECHANICAL DATA

DIM.	mm.			inch		
	MIN.	TYP	MAX.	MIN.	TYP.	MAX.
a1	0.51			0.020		
B	0.77		1.65	0.030		0.065
b		0.5			0.020	
b1		0.25			0.010	
D			20			0.787
E		8.5			0.335	
e		2.54			0.100	
e3		17.78			0.700	
F			7.1			0.280
I			5.1			0.201
L		3.3			0.130	
Z			1.27			0.050

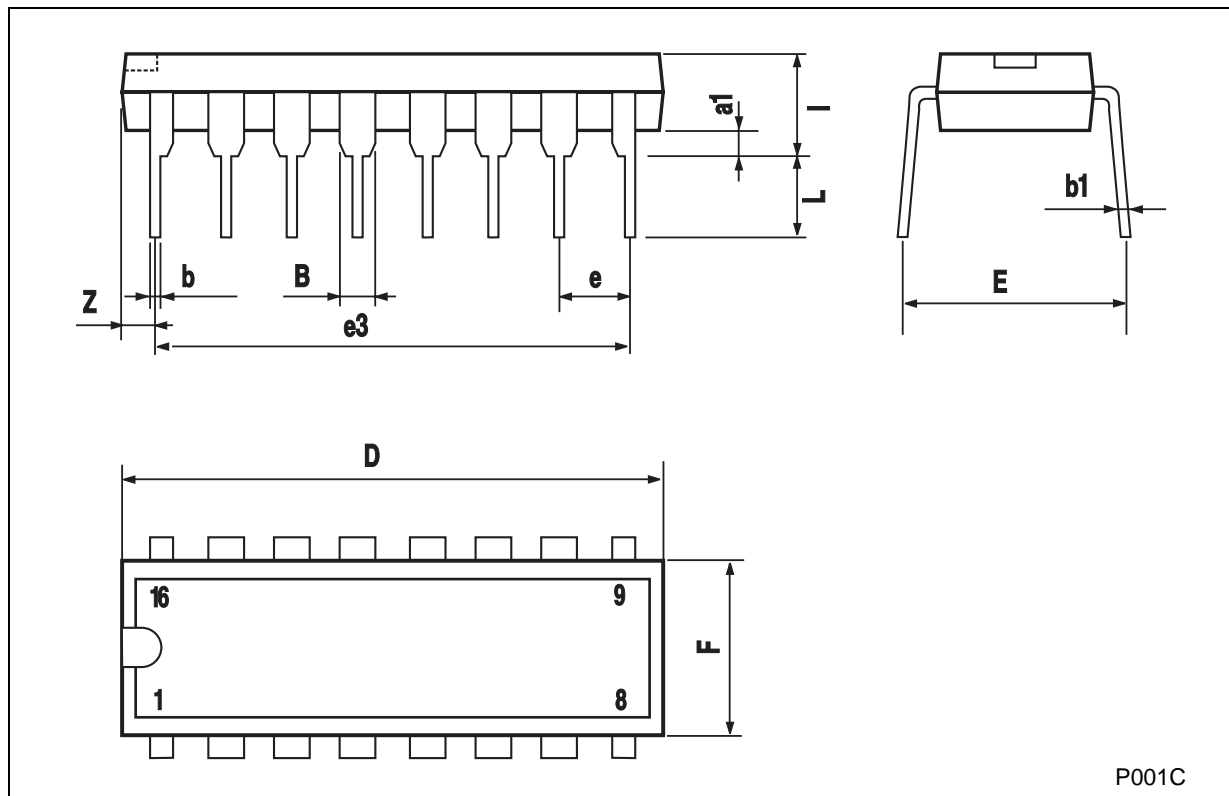

P001C

SO-16 MECHANICAL DATA

DIM.	mm.			inch		
	MIN.	TYP.	MAX.	MIN.	TYP.	MAX.
A			1.75			0.068
a1	0.1		0.2	0.003		0.007
a2			1.65			0.064
b	0.35		0.46	0.013		0.018
b1	0.19		0.25	0.007		0.010
C		0.5			0.019	
c1	45° (typ.)					
D	9.8		10	0.385		0.393
E	5.8		6.2	0.228		0.244
e		1.27			0.050	
e3		8.89			0.350	
F	3.8		4.0	0.149		0.157
G	4.6		5.3	0.181		0.208
L	0.5		1.27	0.019		0.050
M			0.62			0.024
S	8° (max.)					

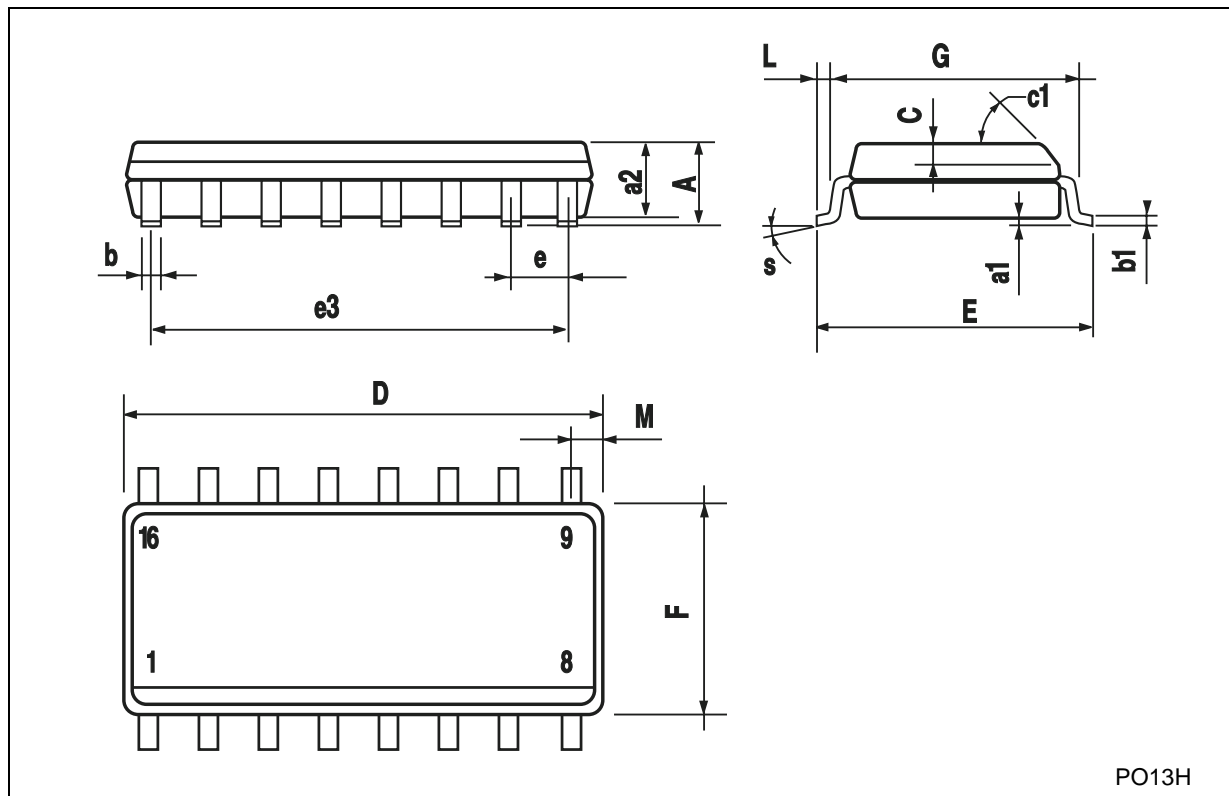

PO13H

TSSOP16 MECHANICAL DATA

DIM.	mm.			inch		
	MIN.	TYP.	MAX.	MIN.	TYP.	MAX.
A			1.2			0.047
A1	0.05		0.15	0.002	0.004	0.006
A2	0.8	1	1.05	0.031	0.039	0.041
b	0.19		0.30	0.007		0.012
c	0.09		0.20	0.004		0.0089
D	4.9	5	5.1	0.193	0.197	0.201
E	6.2	6.4	6.6	0.244	0.252	0.260
E1	4.3	4.4	4.48	0.169	0.173	0.176
e		0.65 BSC			0.0256 BSC	
K	0°		8°	0°		8°
L	0.45	0.60	0.75	0.018	0.024	0.030

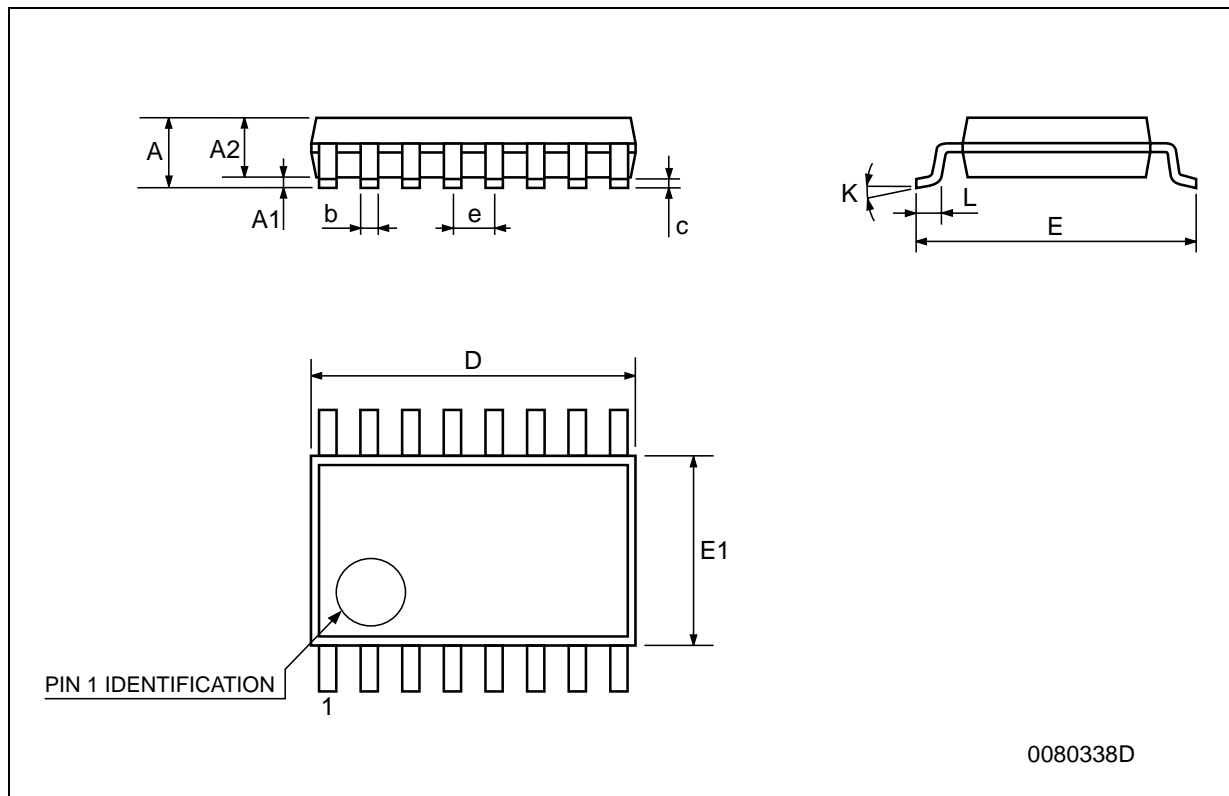

Information furnished is believed to be accurate and reliable. However, STMicroelectronics assumes no responsibility for the consequences of use of such information nor for any infringement of patents or other rights of third parties which may result from its use. No license is granted by implication or otherwise under any patent or patent rights of STMicroelectronics. Specifications mentioned in this publication are subject to change without notice. This publication supersedes and replaces all information previously supplied. STMicroelectronics products are not authorized for use as critical components in life support devices or systems without express written approval of STMicroelectronics.

© The ST logo is a registered trademark of STMicroelectronics

© 2001 STMicroelectronics - Printed in Italy - All Rights Reserved
STMicroelectronics GROUP OF COMPANIES

Australia - Brazil - China - Finland - France - Germany - Hong Kong - India - Italy - Japan - Malaysia - Malta - Morocco
Singapore - Spain - Sweden - Switzerland - United Kingdom

© <http://www.st.com>