

JW075A5, JW075B5, JW075C5 Power Modules: dc-dc Converters: 36 Vdc to 75 Vdc Input; 5 Vdc, 12 Vdc, or 15 Vdc Output; 75 W

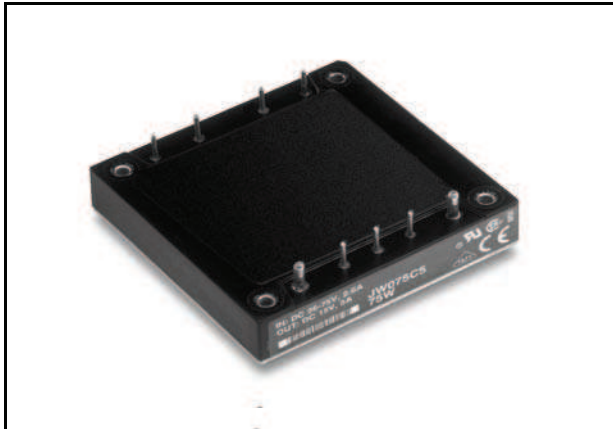

The JW075A5, JW075B5, and JW075C5 Power Modules use advanced, surface-mount technology and deliver high-quality, efficient, and compact dc-dc conversion.

Applications

- Distributed power architectures
- Workstations
- Computer equipment
- Communications equipment

Options

- Heat sinks available for extended operation
- Choice of remote on/off logic configuration

Description

The JW075A5, JW075B5, and JW075C5 Power Modules are dc-dc converters that operate over an input voltage range of 36 Vdc to 75 Vdc and provide a precisely regulated dc output. The output are fully isolated from the input, allowing versatile polarity configurations and grounding connections. The modules have a maximum power rating of 75 W at a typical full-load efficiency of 85%.

The sealed modules offer a metal baseplate for excellent thermal performance. Threaded-through holes are provided to allow easy mounting or addition of a heat sink for high-temperature applications. The standard feature set includes remote sensing, output trim, and remote on/off for convenient flexibility in distributed power applications.

Features

- Low noise
- Small size: 61.0 mm x 57.9 mm x 13.5 mm (2.40 in. x 2.28 in. x 0.53 in.)
- High power density
- High efficiency: 85% typical
- Constant frequency
- Industry-standard pinout
- Metal baseplate
- Case ground pin
- 2:1 input voltage range
- Overcurrent and overvoltage protection
- Remote sense
- Remote on/off
- Output voltage set point adjustment (trim)
- ISO9001 Certified manufacturing facilities
- *UL** 1950 Recognized, *CSA*† C22.2 No. 950-95 Certified, and VDE 0805 (EN60950, IEC950) Licensed
- CE mark meets 73/23/EEC and 93/68/EEC directives‡

* *UL* is a registered trademark of Underwriters Laboratories, Inc.

† *CSA* is a registered trademark of Canadian Standards Assn.

‡ This product is intended for integration into end-use equipment. All the required procedures for CE marking of end-use equipment should be followed. (The CE mark is placed on selected products.)

Absolute Maximum Ratings

Stresses in excess of the absolute maximum ratings can cause permanent damage to the device. These are absolute stress ratings only. Functional operation of the device is not implied at these or any other conditions in excess of those given in the operations sections of the data sheet. Exposure to absolute maximum ratings for extended periods can adversely affect device reliability.

| Parameter | Symbol | Min | Max | Unit |
|---|----------------|-----|------|------|
| Input Voltage: Continuous: JW075A5, JW075B5 | V_I | — | 80 | Vdc |
| JW075C5 | V_I | — | — | Vdc |
| Transient (100 ms; JW075C5 only) | $V_{I, trans}$ | — | 100 | V |
| I/O Isolation Voltage (for 1 minute) | — | — | 1500 | Vdc |
| Operating Case Temperature (See Thermal Considerations section.) | T_C | -40 | 100 | °C |
| Storage Temperature | T_{stg} | -55 | 125 | °C |

Electrical Specifications

Unless otherwise indicated, specifications apply over all operating input voltage, resistive load, and temperature conditions.

Table 1. Input Specifications

| Parameter | Symbol | Min | Typ | Max | Unit |
|--|--------------|-----|-----|-----|------------------|
| Operating Input Voltage | V_I | 36 | 48 | 75 | Vdc |
| Maximum Input Current ($V_I = 0\text{ V}$ to 75 V ; $I_O = I_{O, max}$) | $I_{I, max}$ | — | — | 2.6 | A |
| Inrush Transient | i^2t | — | — | 1.0 | A ² s |
| Input Reflected-ripple Current, Peak-to-peak (5 Hz to 20 MHz, 12 μ H source impedance; see Figure 11.) | I_r | — | 5 | — | mAp-p |
| Input Ripple Rejection (120 Hz) | — | — | 60 | — | dB |

Fusing Considerations

CAUTION: This power module is not internally fused. An input line fuse must always be used.

This encapsulated power module can be used in a wide variety of applications, ranging from simple stand-alone operation to an integrated part of a sophisticated power architecture. To preserve maximum flexibility, internal fusing is not included; however, to achieve maximum safety and system protection, always use an input line fuse. The safety agencies require a normal-blow fuse with a maximum rating of 20 A (see Safety Considerations section). Based on the information provided in this data sheet on inrush energy and maximum dc input current, the same type of fuse with a lower rating can be used. Refer to the fuse manufacturer's data for further information.

Electrical Specifications (continued)

Table 2. Output Specifications

| Parameter | Device | Symbol | Min | Typ | Max | Unit |
|---|---------|---------------------|-------|------|-------------------|-----------------------|
| Output Voltage Set Point ($V_I = 48\text{ V}$; $I_O = I_{O, \text{max}}$; $T_C = 25\text{ }^\circ\text{C}$) | JW075A5 | $V_{O, \text{set}}$ | 4.92 | 5.0 | 5.08 | Vdc |
| | JW075B5 | $V_{O, \text{set}}$ | 11.78 | 12.0 | 12.22 | Vdc |
| | JW075C5 | $V_{O, \text{set}}$ | 14.73 | 15.0 | 15.27 | Vdc |
| Output Voltage (Over all operating input voltage, resistive load, and temperature conditions until end of life. See Figure 13.) | JW075A5 | V_O | 4.85 | — | 5.15 | Vdc |
| | JW075B5 | V_O | 11.64 | — | 12.36 | Vdc |
| | JW075C5 | V_O | 14.55 | — | 15.45 | Vdc |
| Output Regulation: Line ($V_I = 36\text{ V}$ to 75 V) Load ($I_O = I_{O, \text{min}}$ to $I_{O, \text{max}}$) Temperature ($T_C = -40\text{ }^\circ\text{C}$ to $+100\text{ }^\circ\text{C}$) | All | — | — | 0.01 | 0.2 | % V_O |
| | All | — | — | 0.05 | 0.4 | % V_O |
| | All | — | — | 15 | 50 | mV |
| Output Ripple and Noise Voltage (See Figure 12.): RMS Peak-to-peak (5 Hz to 20 MHz) | JW075A5 | — | — | — | 40 | mVrms |
| | JW075B5 | — | — | — | 50 | mVrms |
| | JW075C5 | — | — | — | 60 | mVrms |
| | JW075A5 | — | — | — | 150 | mVp-p |
| | JW075B5 | — | — | — | 200 | mVp-p |
| | JW075C5 | — | — | — | 250 | mVp-p |
| External Load Capacitance | All | — | 0 | — | * | μF |
| Output Current (At $I_O < I_{O, \text{min}}$, the modules may exceed output ripple specifications.) | JW075A5 | I_O | 0.5 | — | 15 | A |
| | JW075B5 | I_O | 0.3 | — | 6.3 | A |
| | JW075C5 | I_O | 0.3 | — | 5.0 | A |
| Output Current-limit Inception ($V_O = 90\%$ of $V_{O, \text{nom}}$) | JW075A5 | $I_{O, \text{cli}}$ | — | 18.0 | 19.5 [†] | A |
| | JW075B5 | $I_{O, \text{cli}}$ | — | 7.6 | 8.1 [†] | A |
| | JW075C5 | $I_{O, \text{cli}}$ | — | 5.8 | 7.0 [†] | A |
| Output Short-circuit Current ($V_O = 250\text{ mV}$) | All | — | — | 170 | — | % $I_{O, \text{max}}$ |
| Efficiency ($V_I = 48\text{ V}$; $I_O = I_{O, \text{max}}$; $T_C = 25\text{ }^\circ\text{C}$) | JW075A5 | η | — | 81 | — | % |
| | JW075B5 | η | — | 83 | — | % |
| | JW075C5 | η | — | 84 | — | % |
| Switching Frequency | All | — | — | 500 | — | kHz |
| Dynamic Response ($\dot{I}_O/\dot{I}_T = 1\text{ A}/10\text{ }\mu\text{s}$, $V_I = 48\text{ V}$, $T_C = 25\text{ }^\circ\text{C}$; tested with a $10\text{ }\mu\text{F}$ aluminum and a $1.0\text{ }\mu\text{F}$ ceramic capacitor across the load): Load Change from $I_O = 50\%$ to 75% of $I_{O, \text{max}}$: Peak Deviation Settling Time ($V_O < 10\%$ of peak deviation) Load Change from $I_O = 50\%$ to 25% of $I_{O, \text{max}}$: Peak Deviation Settling Time ($V_O < 10\%$ of peak deviation) | All | — | — | 2 | — | % $V_{O, \text{set}}$ |
| | All | — | — | 300 | — | μs |
| | All | — | — | 2 | — | % $V_{O, \text{set}}$ |
| | All | — | — | 300 | — | μs |

* Consult your sales representative or the factory.

† These are manufacturing test limits. In some situations, results may differ.

Electrical Specifications (continued)

Table 3. Isolation Specifications

| Parameter | Min | Typ | Max | Unit |
|-----------------------|-----|------|-----|------------|
| Isolation Capacitance | — | 2500 | — | pF |
| Isolation Resistance | 10 | — | — | M Ω |

General Specifications

| Parameter | Min | Typ | Max | Unit |
|---|-----------|-----|-----------|---------|
| Calculated MTBF ($I_o = 80\%$ of $I_{o, max}$; $T_c = 40\text{ }^\circ\text{C}$) | 3,000,000 | | | hr. |
| Weight | — | — | 100 (3.5) | g (oz.) |

Feature Specifications

Unless otherwise indicated, specifications apply over all operating input voltage, resistive load, and temperature conditions. See Feature Descriptions for additional information.

| Parameter | Device | Symbol | Min | Typ | Max | Unit |
|--|--|---|------------------------|------------------------|------------------------------|---------------------------------------|
| Remote On/Off Signal Interface ($V_i = 0\text{ V}$ to 75 V ; open collector or equivalent compatible; signal referenced to $V_i(-)$ terminal; see Figure 14 and Feature Descriptions.): Logic Low—Module Off Logic High—Module On Logic Low: At $I_{on/off} = 1.0\text{ mA}$ At $V_{on/off} = 0.0\text{ V}$ Logic High: At $I_{on/off} = 0.0\text{ }\mu\text{A}$ Leakage Current Turn-on Time ($I_o = 80\%$ of $I_{o, max}$; V_o within $\pm 1\%$ of steady state; see Figure 10.) | All All All All All All | $V_{on/off}$ $I_{on/off}$ $V_{on/off}$ $I_{on/off}$ — | 0 — — — — | — — — — 20 | 1.2 1.0 15 50 35 | V mA V μA ms |
| Output Voltage Adjustment (See Feature Descriptions.): Output Voltage Remote-sense Range Output Voltage Set-point Adjustment Range (trim) Note: Ensure that the combination of the remote-sense and the trim does not exceed 15.5 V on the output of the JW075C5 module. | All JW075A5, B5 JW075C5 | — — — | — 60 50 | — — — | 0.5 110 103 | V $\%V_{O, nom}$ $\%V_{O, nom}$ |
| Output Overvoltage Protection | JW075A5 JW075B5 JW075C5 | $V_{O, clamp}$ $V_{O, clamp}$ $V_{O, clamp}$ | 5.5* 13.2* 16.5* | — — — | 7.0* 16.0* 20.0* | V V V |

These are manufacturing test limits. In some situations, results may differ.

Characteristic Curves

The following figures provide typical characteristics for the power modules.

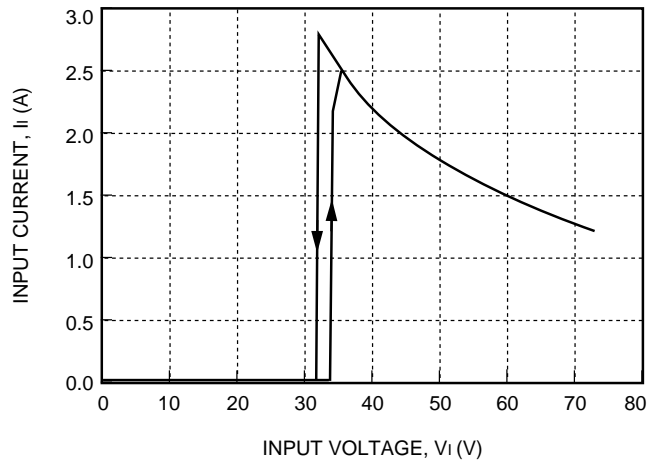

8-1131 (C)

Figure 1. Typical JW075A5 Input Characteristics at Room Temperature

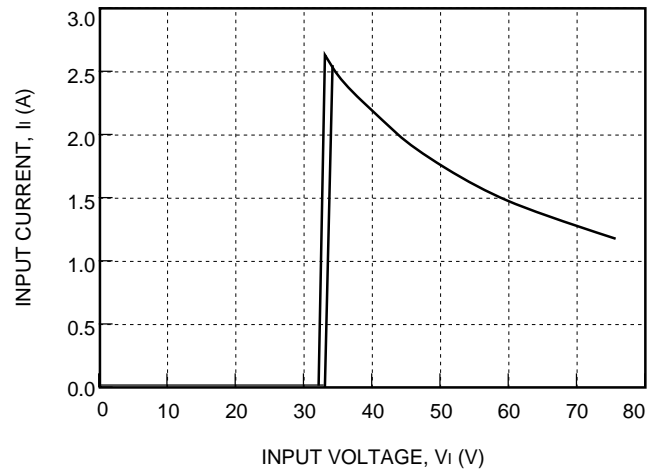

8-1770 (C)

Figure 3. Typical JW075C5 Input Characteristics at Room Temperature

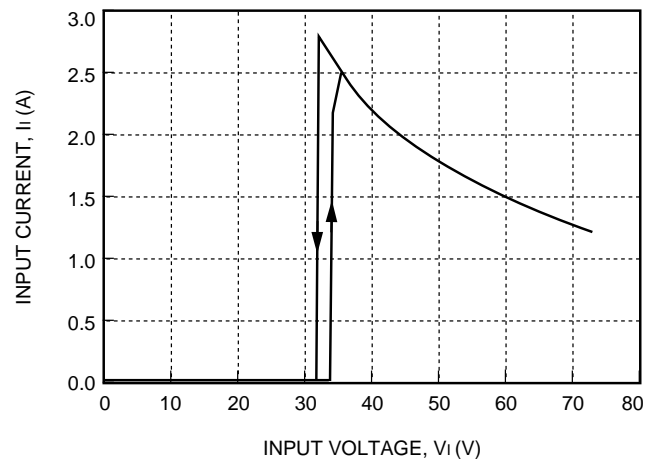

8-1131 (C)

Figure 2. Typical JW075B5 Input Characteristics at Room Temperature

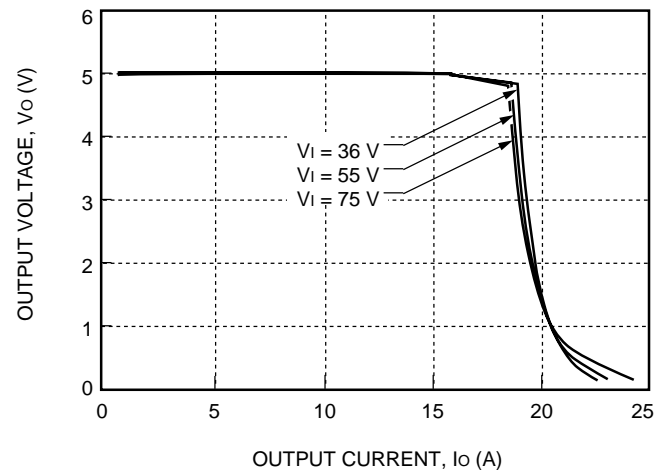

8-1519 (C)

Figure 4. Typical JW075A5 Output Characteristics at Room Temperature

Characteristic Curves (continued)

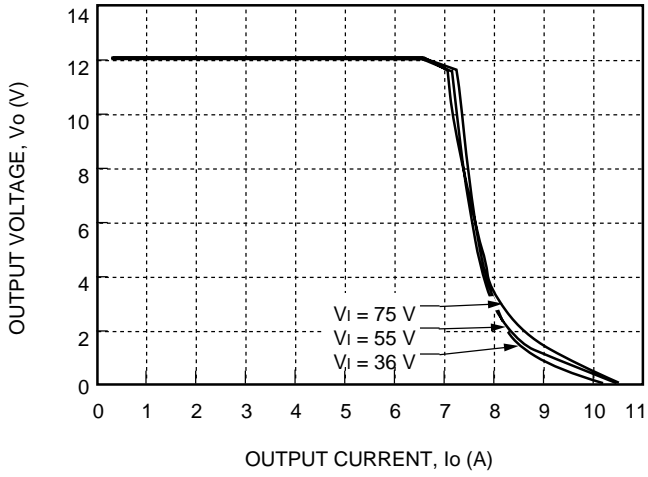

8-1520 (C)

Figure 5. Typical JW075B5 Output Characteristics at Room Temperature

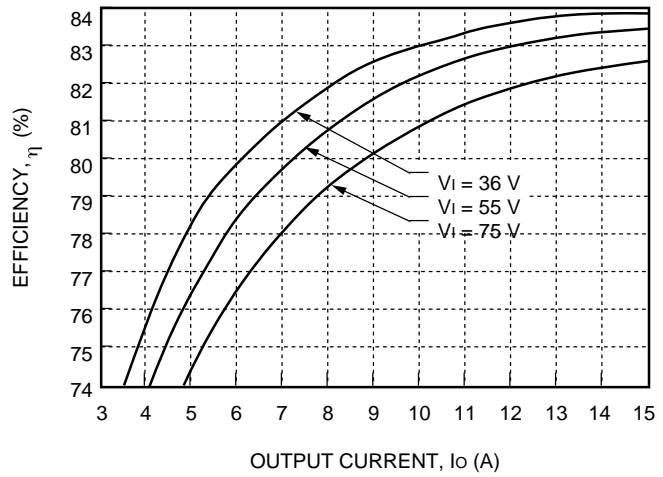

8-1522 (C)

Figure 7. Typical JW075A5 Converter Efficiency vs. Output Current at Room Temperature

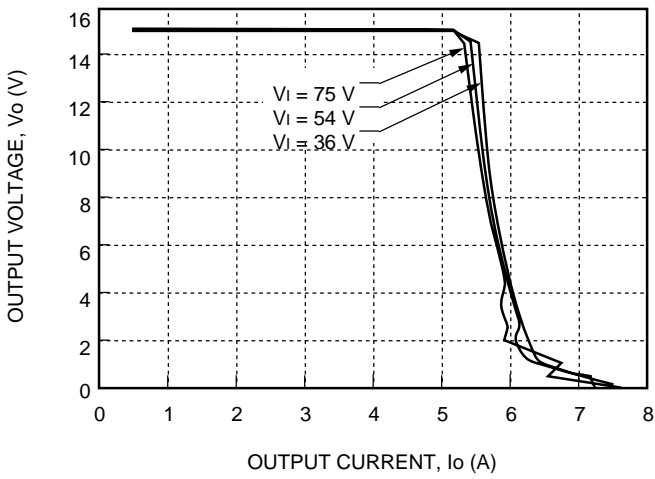

8-1521 (C)

Figure 6. Typical JW075C5 Output Characteristics at Room Temperature

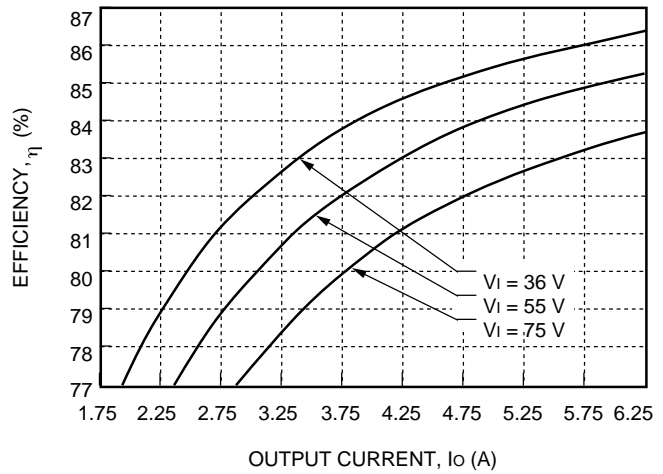

8-1523 (C)

Figure 8. Typical JW075B5 Converter Efficiency vs. Output Current at Room Temperature

Characteristic Curves (continued)

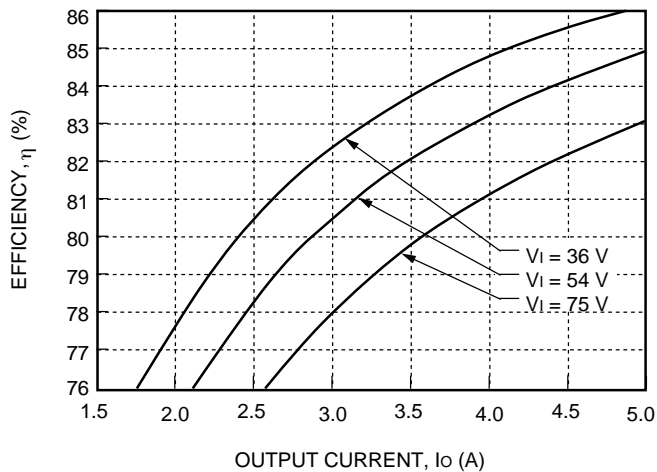

8-1524 (C)

Figure 9. Typical JW075C5 Converter Efficiency vs. Output Current at Room Temperature

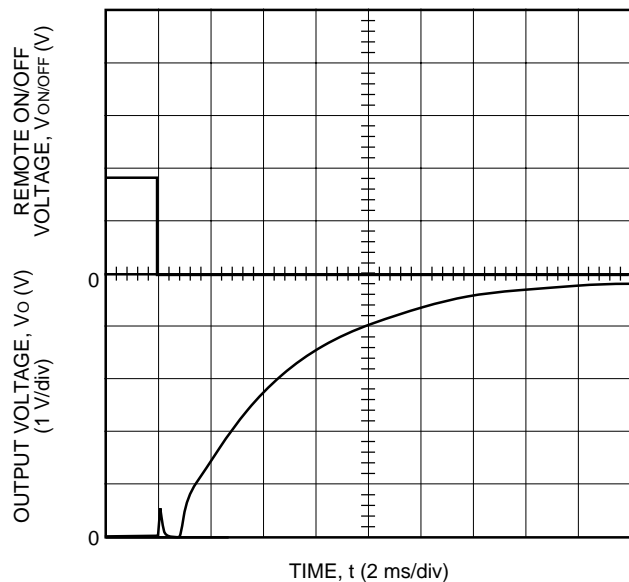

8-1525 (C)

Note: Tested with a 10 μ F aluminum and a 1.0 μ F ceramic capacitor across the load.

Figure 10. Typical Start-Up from Remote On/Off JW075A5; $I_o = I_{o, max}$

Test Configurations

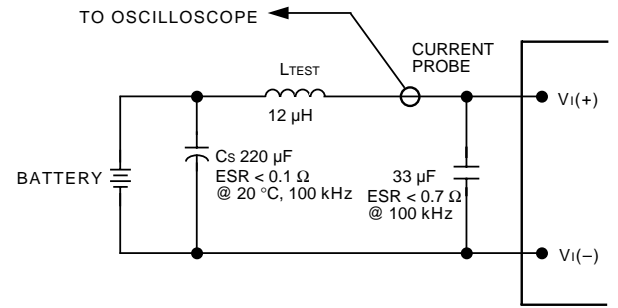

8-203 (C).1

Note: Measure input reflected-ripple current with a simulated source inductance (L_{TEST}) of 12 μ H. Capacitor C_s offsets possible battery impedance. Measure current as shown above.

Figure 11. Input Reflected-Ripple Test Setup

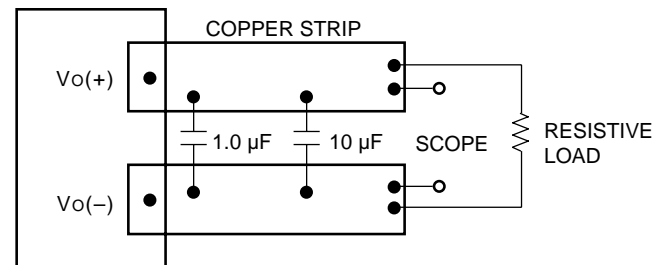

8-513 (C).d

Note: Use a 1.0 μ F ceramic capacitor and a 10 μ F aluminum or tantalum capacitor. Scope measurement should be made using a BNC socket. Position the load between 51 mm and 76 mm (2 in. and 3 in.) from the module.

Figure 12. Peak-to-Peak Output Noise Measurement Test Setup

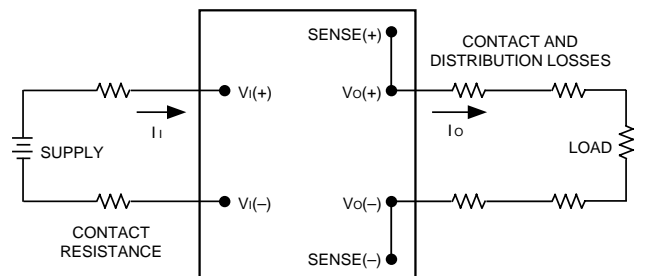

8-749 (C)

Note: All measurements are taken at the module terminals. When socketing, place Kelvin connections at module terminals to avoid measurement errors due to socket contact resistance.

$$\eta = \left(\frac{[V_{o(+)} - V_{o(-)}] I_o}{[V_{i(+)} - V_{i(-)}] I_i} \right) \times 100 \quad \%$$

Figure 13. Output Voltage and Efficiency Measurement Test Setup

Design Considerations

Input Source Impedance

The power module should be connected to a low ac-impedance input source. Highly inductive source impedances can affect the stability of the power module. For the test configuration in Figure 14, a 33 μF electrolytic capacitor (ESR < 0.7 Ω at 100 kHz) mounted close to the power module helps ensure stability of the unit. For other highly inductive source impedances, consult the factory for further application guidelines.

Safety Considerations

For safety-agency approval of the system in which the power module is used, the power module must be installed in compliance with the spacing and separation requirements of the end-use safety agency standard, i.e., UL1950, CSA C22.2 No. 950-95, and VDE 0805 (EN60950, IEC950).

If the input source is non-SELV (ELV or a hazardous voltage greater than 60 Vdc and less than or equal to 75 Vdc), for the module's output to be considered meeting the requirements of safety extra-low voltage (SELV), all of the following must be true:

- The input source is to be provided with reinforced insulation from any hazardous voltages, including the ac mains.
- One V_I pin and one V_O pin are to be grounded or both the input and output pins are to be kept floating.
- The input pins of the module are not operator accessible.
- Another SELV reliability test is conducted on the whole system, as required by the safety agencies, on the combination of supply source and the subject module to verify that under a single fault, hazardous voltages do not appear at the module's output.

Note: Do not ground either of the input pins of the module without grounding one of the output pins. This may allow a non-SELV voltage to appear between the output pin and ground.

The power module has extra-low voltage (ELV) outputs when all inputs are ELV.

The input to these units is to be provided with a maximum 20 A normal-blow fuse in the ungrounded lead.

Feature Descriptions

Overcurrent Protection

To provide protection in a fault (output overload) condition, the unit is equipped with internal current-limiting circuitry and can endure current limiting for an unlimited duration. At the point of current-limit inception, the unit shifts from voltage control to current control. If the output voltage is pulled very low during a severe fault, the current-limit circuit can exhibit either foldback or tailout characteristics (output current decrease or increase). The unit operates normally once the output current is brought back into its specified range.

Remote On/Off

The remote on/off turns the module on during a logic-high voltage on the ON/OFF pin, and off during a logic low.

To turn the power module on and off, the user must supply a switch to control the voltage between the on/off terminal and the $V_I(-)$ terminal ($V_{on/off}$). The switch can be an open collector or equivalent (see Figure 14). A logic low is $V_{on/off} = 0 \text{ V}$ to 1.2 V. The maximum $I_{on/off}$ during a logic low is 1 mA. The switch should maintain a logic-low voltage while sinking 1 mA.

During a logic high, the maximum $V_{on/off}$ generated by the power module is 15 V. The maximum allowable leakage current of the switch at $V_{on/off} = 15 \text{ V}$ is 50 μA .

If not using the remote on/off feature, leave the ON/OFF pin open.

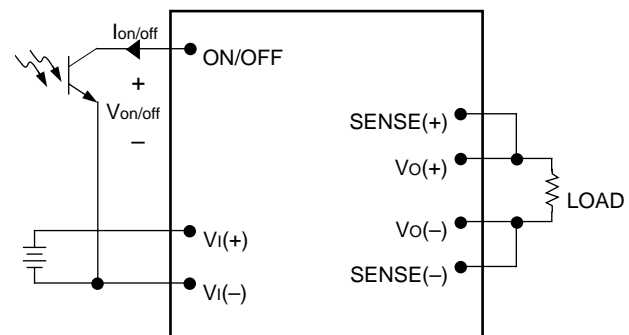

8-720 (C).c

Figure 14. Remote On/Off Implementation

Feature Descriptions (continued)

Remote Sense

Remote sense minimizes the effects of distribution losses by regulating the voltage at the remote-sense connections. The voltage between the remote-sense pins and the output terminals must not exceed the output voltage sense range given in the Feature Specifications table, i.e.:

$$[V_o(+)-V_o(-)]-[SENSE(+)-SENSE(-)] \leq 0.5\text{ V}$$

For JW075A5 and JW075B5, the voltage between the $V_o(+)$ and $V_o(-)$ terminals must not exceed the minimum output overvoltage clamp voltage as indicated in the Feature Specifications table. For the JW075C5, the voltage between the $V_o(+)$ and $V_o(-)$ terminals must not exceed 15.5 V. This limit includes any increase in voltage due to remote-sense compensation and output voltage set-point adjustment (trim). See Figure 15.

If not using the remote-sense feature to regulate the output at the point of load, then connect SENSE(+) to $V_o(+)$ and SENSE(-) to $V_o(-)$ at the module.

Although the output voltage can be increased by both the remote sense and by the trim, the maximum increase for the output voltage is not the sum of both. The maximum increase is the larger of either the remote sense or the trim. Consult the factory if you need to increase the output voltage more than the above limitation.

The amount of power delivered by the module is defined as the voltage at the output terminals multiplied by the output current. When using remote sense and trim, the output voltage of the module can be increased, which at the same output current would increase the power output of the module. Care should be taken to ensure that the maximum output power of the module remains at or below the maximum rated power.

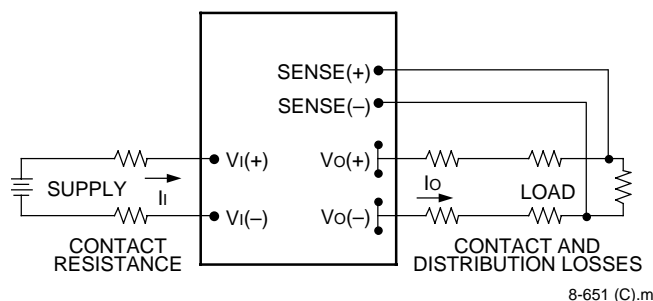

Figure 15. Effective Circuit Configuration for Single-Module Remote-Sense Operation

Output Voltage Set-Point Adjustment (Trim)

Output voltage trim allows the user to increase or decrease the output voltage set point of a module. This is accomplished by connecting an external resistor between the TRIM pin and either the SENSE(+) or SENSE(-) pins. The trim resistor should be positioned close to the module.

If not using the trim feature, leave the TRIM pin open.

With an external resistor between the TRIM and SENSE(-) pins ($R_{adj-down}$), the output voltage set point ($V_{o,adj}$) decreases (see Figure 18). The following equation determines the required external-resistor value to obtain a percentage output voltage change of $\Delta\%$.

$$R_{adj-down} = \left(\frac{100}{\Delta\%} - 2 \right) \text{ k}\Omega$$

The test results for this configuration are displayed in Figure 17. This figure applies to all output voltages.

With an external resistor connected between the TRIM and SENSE(+) pins (R_{adj-up}), the output voltage set point ($V_{o,adj}$) increases (see Figure 16).

Note: The output voltage of the JW075C5 module may be increased to a maximum of 0.5 V. The 0.5 V is the combination of both the remote sense and the output voltage set-point adjustment (trim). Do not exceed 15.5 V between the $V_o(+)$ and $V_o(-)$ terminals.

The following equation determines the required external-resistor value to obtain a percentage output voltage change of $\Delta\%$.

$$R_{adj-up} = \left(\frac{V_o(100 + \Delta\%)}{1.225\Delta\%} - \frac{(100 + 2\Delta\%)}{\Delta\%} \right) \text{ k}\Omega$$

Only trim the JW075C5 up 0.5 V maximum. See note above.

The test results for this configuration are displayed in Figure 21.

The voltage between the $V_o(+)$ and $V_o(-)$ terminals must not exceed the minimum output overvoltage clamp voltage as indicated in the Feature Specification table. This limit includes any increase in voltage due to remote-sense compensation and output voltage set-point adjustment (trim). See Figure 15.

Feature Descriptions (continued)

Output Voltage Set-Point Adjustment (Trim)

(continued)

Although the output voltage can be increased by both the remote sense and by the trim, the maximum increase for the output voltage is not the sum of both. The maximum increase is the larger of either the remote sense or the trim. Consult the factory if you need to increase the output voltage more than the above limitation.

The amount of power delivered by the module is defined as the voltage at the output terminals multiplied by the output current. When using remote sense and trim, the output voltage of the module can be increased, which at the same output current would increase the power output of the module. Care should be taken to ensure that the maximum output power of the module remains at or below the maximum rated power.

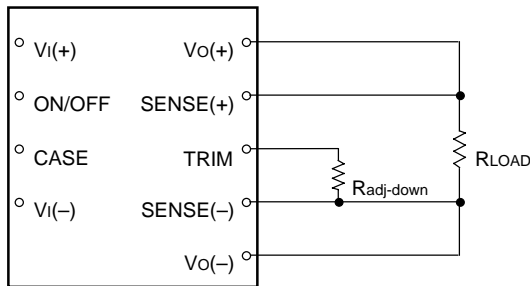

8-748 (C).b

Figure 16. Circuit Configuration to Decrease Output Voltage

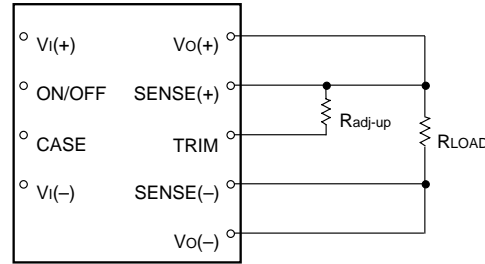

8-715 (C).b

Figure 18. Circuit Configuration to Increase Output Voltage

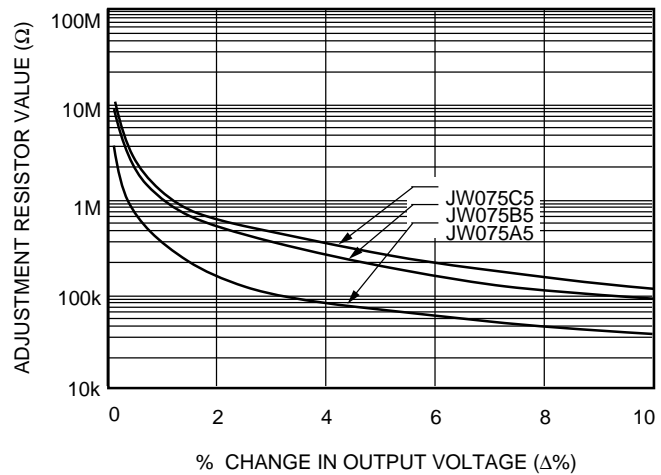

8-1969 (C)

Figure 19. Resistor Selection for Increased Output Voltage

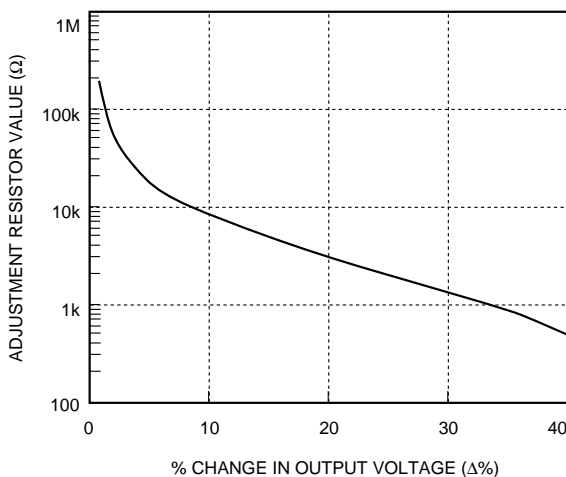

8-879 (C)

Figure 17. Resistor Selection for Decreased Output Voltage

Output Overvoltage Protection

The output overvoltage clamp consists of control circuitry, independent of the primary regulation loop, that monitors the voltage on the output terminals. The control loop of the clamp has a higher voltage set point than the primary loop (see Feature Specifications table). This provides a redundant voltage control that reduces the risk of output overvoltage.

Thermal Considerations

Introduction

The power modules operate in a variety of thermal environments; however, sufficient cooling should be provided to help ensure reliable operation of the unit. Heat-dissipating components inside the unit are thermally coupled to the case. Heat is removed by conduction, convection, and radiation to the surrounding environment. Proper cooling can be verified by measuring the case temperature. Peak temperature (T_c) occurs at the position indicated in Figure 20.

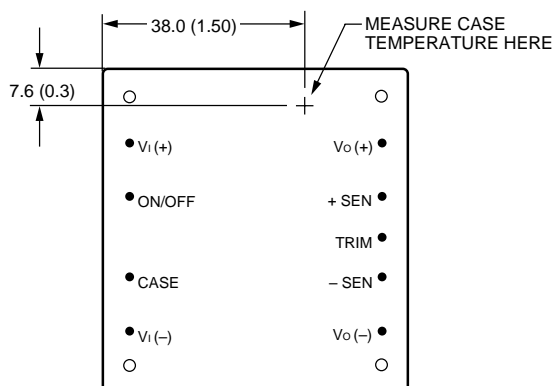

Note: Top view, pin locations are for reference only.
Measurements shown in millimeters and (inches).

Figure 20. Case Temperature Measurement Location

The temperature at this location should not exceed 100 °C. The output power of the module should not exceed the rated power for the module as listed in the Ordering Information table.

Although the maximum case temperature of the power modules is 100 °C, you can limit this temperature to a lower value for extremely high reliability.

For additional information on these modules, refer to the *Thermal Management JC-, JFC-, JW-, and JFW-Series 50 W to 150 W Board-Mounted Power Modules Technical Note (TN97-008EPS)*.

Heat Transfer Without Heat Sinks

Increasing airflow over the module enhances the heat transfer via convection. Figure 21 shows the maximum power that can be dissipated by the module without exceeding the maximum case temperature versus local ambient temperature (T_A) for natural convection through 4 m/s (800 ft./min.).

Note that the natural convection condition was measured at 0.05 m/s to 0.1 m/s (10 ft./min. to 20 ft./min.); however, systems in which these power modules may be used typically generate natural convection airflow rates of 0.3 m/s (60 ft./min.) due to other heat dissipating components in the system. The use of Figure 21 is shown in the following example.

Example

What is the minimum airflow necessary for a JW075A5 operating at $V_i = 54$ V, an output current of 15 A, and a maximum ambient temperature of 40 °C?

Solution

Given: $V_i = 54$ V
 $I_o = 15$ A
 $T_A = 40$ °C

Determine P_D (Use Figure 22.):

$$P_D = 14.9 \text{ W}$$

Determine airflow (v) (Use Figure 21.):

$$v = 1.6 \text{ m/s (320 ft./min.)}$$

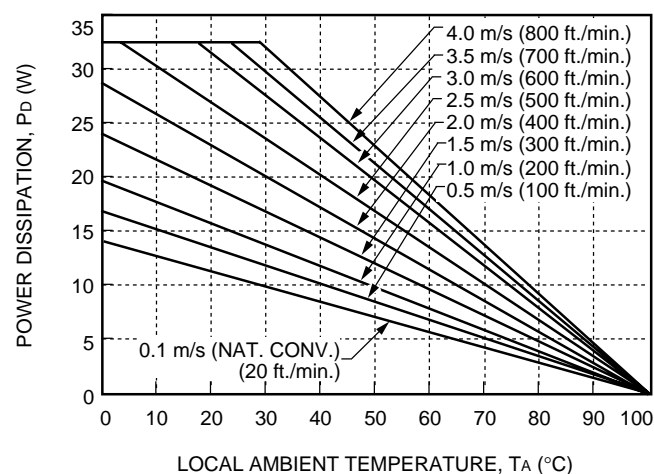

Figure 21. Forced Convection Power Derating with No Heat Sink; Either Orientation

Thermal Considerations (continued)

Heat Transfer Without Heat Sinks (continued)

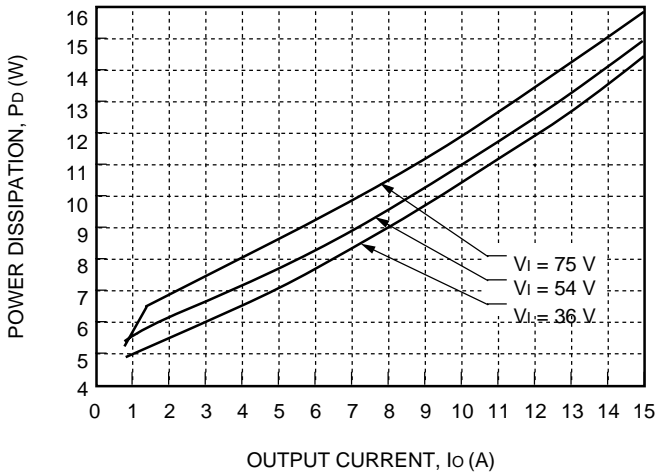

Figure 22. JW075A5 Power Dissipation vs. Output Current

8-1526 (C)

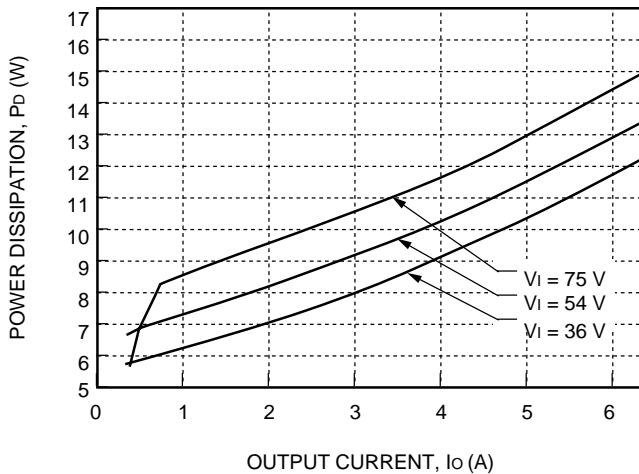

Figure 23. JW075B5 Power Dissipation vs. Output Current

8-1527 (C)

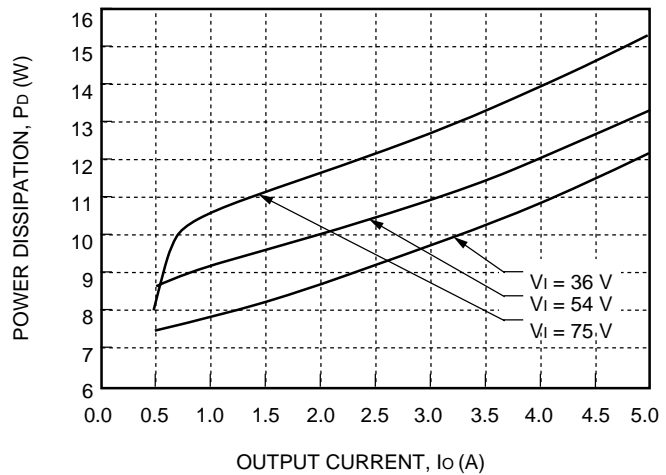

Figure 24. JW075C5 Power Dissipation vs. Output Current

8-1528 (C)

Heat Transfer with Heat Sinks

The power modules have through-threaded, M3 x 0.5 mounting holes, which enable heat sinks or cold plates to attach to the module. The mounting torque must not exceed 0.56 N-m (5 in.-lb.). For a screw attachment from the pin side, the recommended hole size on the customer's PWB around the mounting holes is 0.130 ± 0.005 inches. If a larger hole is used, the mounting torque from the pin side must not exceed 0.25 N-m (2.2 in.-lb.).

Thermal derating with heat sinks is expressed by using the overall thermal resistance of the module. Total module thermal resistance (θ_{ca}) is defined as the maximum case temperature rise ($\Delta T_{c, max}$) divided by the module power dissipation (P_D):

$$\theta_{ca} = \left[\frac{\Delta T_{c, max}}{P_D} \right] = \left[\frac{(T_C - T_A)}{P_D} \right]$$

The location to measure case temperature (T_C) is shown in Figure 20. Case-to-ambient thermal resistance vs. airflow is shown, for various heat sink configurations and heights, in Figure 25. These curves were obtained by experimental testing of heat sinks, which are offered in the product catalog.

Thermal Considerations (continued)

Heat Transfer with Heat Sinks (continued)

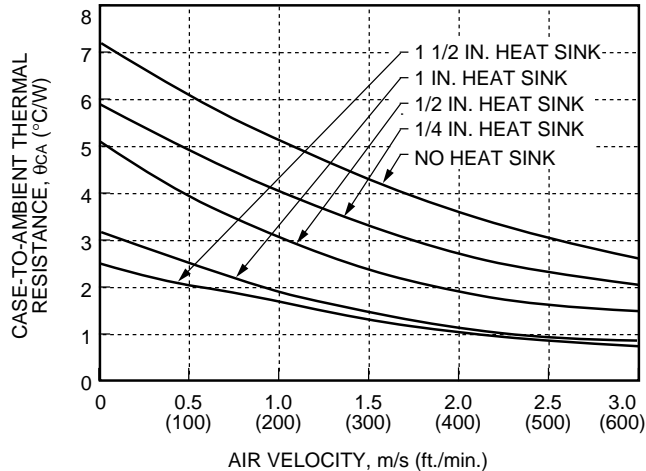

8-1153 (C)

Figure 25. Case-to-Ambient Thermal Resistance Curves; Either Orientation

These measured resistances are from heat transfer from the sides and bottom of the module as well as the top side with the attached heat sink; therefore, the case-to-ambient thermal resistances shown are generally lower than the resistance of the heat sink by itself. The module used to collect the data in Figure 25 had a thermal-conductive dry pad between the case and the heat sink to minimize contact resistance. The use of Figure 25 is shown in the following example.

Example

If an 85 °C case temperature is desired, what is the minimum airflow necessary? Assume the JW075A5 module is operating at $V_i = 54$ V and an output current of 15 A, maximum ambient air temperature of 40 °C, and the heat sink is 1/2 inch.

Solution

Given: $V_i = 54$ V
 $I_o = 15$ A
 $T_A = 40$ °C
 $T_C = 85$ °C
Heat sink = 1/2 in.

Determine P_D by using Figure 22:

$$P_D = 14.9 \text{ W}$$

Then solve the following equation:

$$\theta_{ca} \equiv \left[\frac{(T_C - T_A)}{P_D} \right]$$

$$\theta_{ca} = \left[\frac{(85 - 40)}{14.9} \right]$$

$$\theta_{ca} = 3.0 \text{ °C/W}$$

Use Figure 25 to determine air velocity for the 1/2 inch heat sink.

The minimum airflow necessary for the JW075A5 module is 1.0 m/s (200 ft./min.).

Custom Heat Sinks

A more detailed model can be used to determine the required thermal resistance of a heat sink to provide necessary cooling. The total module resistance can be separated into a resistance from case-to-sink (θ_{cs}) and sink-to-ambient (θ_{sa}) shown below (Figure 26).

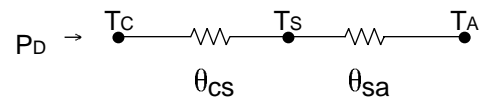

8-1304 (C)

Figure 26. Resistance from Case-to-Sink and Sink-to-Ambient

For a managed interface using thermal grease or foils, a value of $\theta_{cs} = 0.1$ °C/W to 0.3 °C/W is typical. The solution for heat sink resistance is:

$$\theta_{sa} = \left[\frac{(T_C - T_A)}{P_D} \right] - \theta_{cs}$$

This equation assumes that all dissipated power must be shed by the heat sink. Depending on the user-defined application environment, a more accurate model, including heat transfer from the sides and bottom of the module, can be used. This equation provides a conservative estimate for such instances.

Solder, Cleaning, and Drying Considerations

Post solder cleaning is usually the final circuit-board assembly process prior to electrical testing. The result of inadequate circuit-board cleaning and drying can affect both the reliability of a power module and the testability of the finished circuit-board assembly. For guidance on appropriate soldering, cleaning, and drying procedures, refer to the *Board-Mounted Power Modules Soldering and Cleaning* Application Note (AP97-021EPS).

EMC Considerations

For assistance with designing for EMC compliance, please refer to the FLTR100V10 data sheet (DS98-152EPS).

Layout Considerations

Copper paths must not be routed beneath the power module mounting inserts. For additional layout guidelines, refer to the FLTR100V10 data sheet (DS98-152EPS).

Filtering Suggestions for FCC Class B Conducted Emissions Compliance

The JW075A5, JW075B5, and JW075C5 modules are optimized to simplify filtering design to comply with various international emissions standards. The configuration shown in Figure 27 below passed FCC Class B conducted requirements with substantial margin. In order to obtain good results, careful layout practices as shown in Figure 28 must be followed.

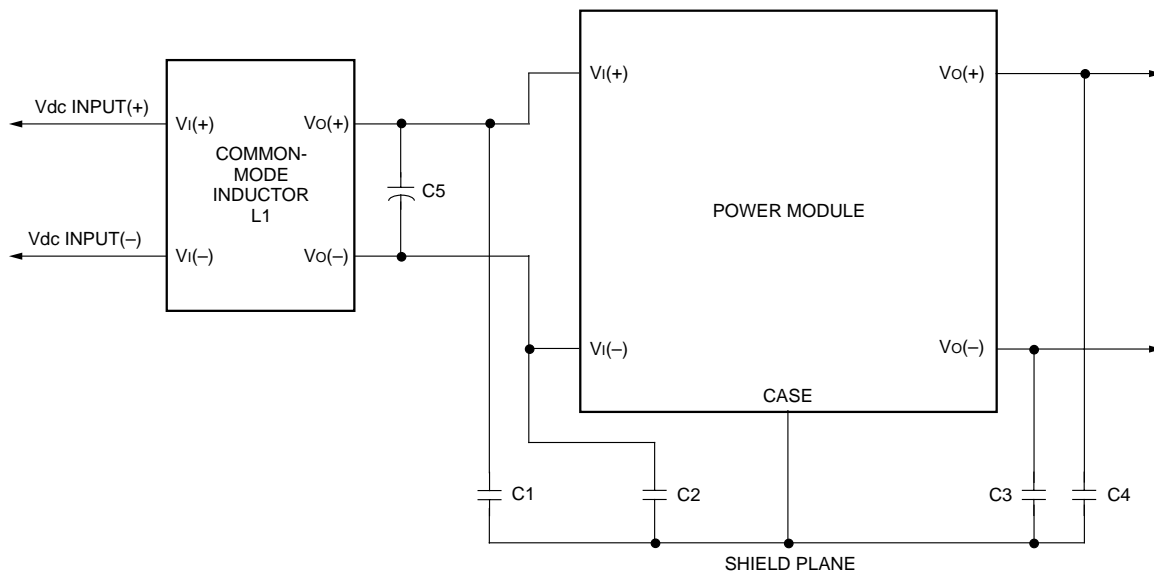

8-1325 (C).c

Figure 27. Recommended Schematic for FCC Class B Filtering

C1 through C4 can be 0.01 μ F to 0.1 μ F. Select the voltage rating to meet input-to-output isolation requirements.

Components that may be used:

- L1 *Siemens** part number B82723-A2402-N1
- C1—C4 Surface-mounted ceramic
- C5 Aluminum electrolytic, low ESR (ESR < 0.7 @ 100 kHz)

* *Siemens* is a trademark of Siemens Aktiengesellschaft.

Filtering Suggestions for FCC Class B Conducted Emissions Compliance (continued)

The common-mode input inductor should present a high impedance to frequencies in the 1 MHz to 30 MHz range. The inductor (L1) should provide good high-frequency attenuation, while offering adequate leakage inductance for differential noise attenuation at the 300 kHz switching frequency. The case capacitors, C1, C2, C3, and C4, should have good high-frequency characteristics up to 30 MHz. Surface-mounted ceramic capacitors mounted close to the module, as shown in Figure 28, provide excellent results. The voltage rating of the case capacitors, C1 through C4, depends on the desired isolation voltage between primary and secondary. For example, the module isolation voltage is 1500 Vdc. To maintain that rating, C1 through C4 must be rated at 750 Vdc each.

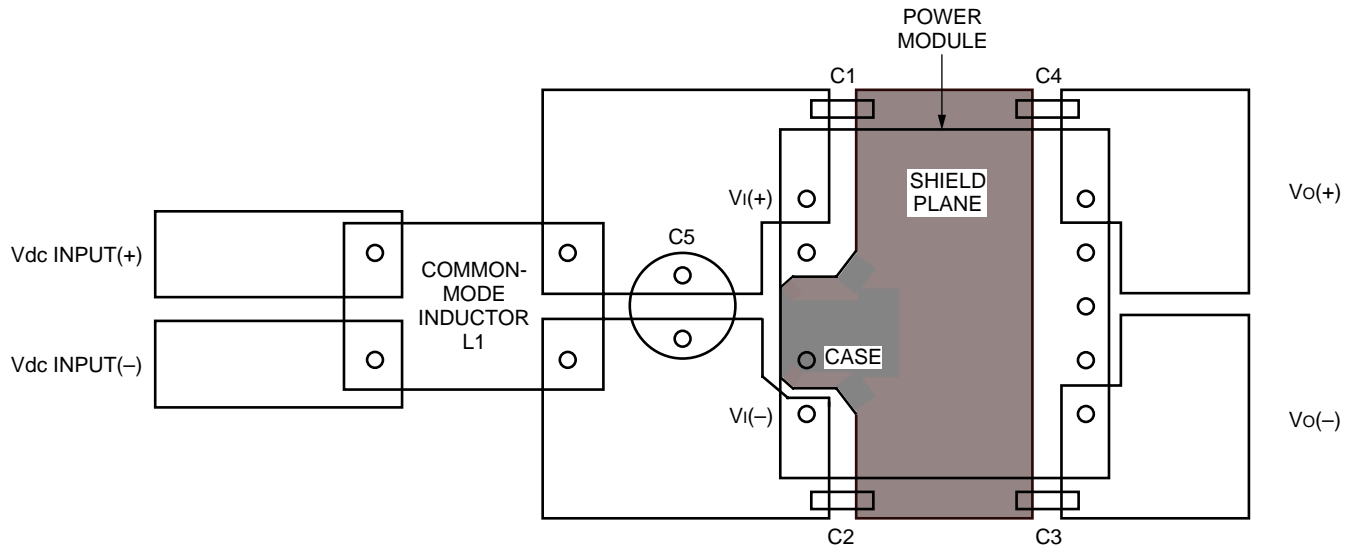

8-1328 (C).e

Figure 28. Recommended Layout for FCC Class B Filtering

Vdc input(+) and Vdc input(-) planes should overlay each other, as should the Vi(+) and Vi(-) planes, as should the Vo(+) and Vo(-) planes. Avoid routing signals or planes under the power module or the filter module. Ensure all connections are low impedance.

Lineage Power also offers a filter module (FLTR100V10, 107742447), which may be used effectively in place of the common-mode inductor shown in Figure 27 and Figure 28.

Note: Please refer to the FLTR100V10 data sheet for applications notes when designing for EMI compliance.

Outline Diagram

Dimensions are in millimeters and (inches).

Tolerances: x.x mm \pm 0.5 mm (x.xx in. \pm 0.02 in.)
x.xx mm \pm 0.25 mm (x.xxx in. \pm 0.010 in.)

Top View

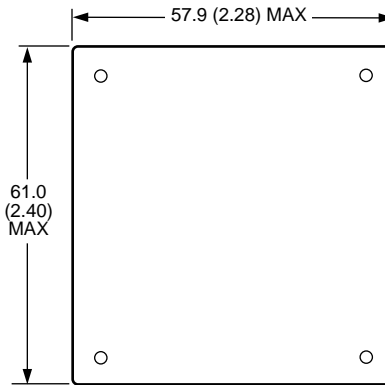

Side View

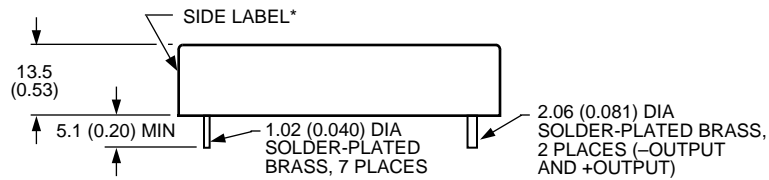

Bottom View

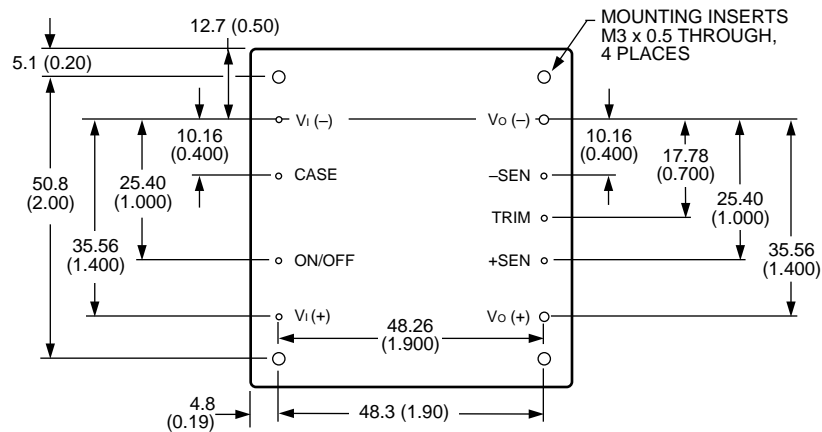

8-1190 (C).g

* Side label includes Lineage name, product designation, safety agency markings, input/output voltage and current ratings, and bar code.

Recommended Hole Pattern

Component-side footprint.

Dimensions are in millimeters and (inches).

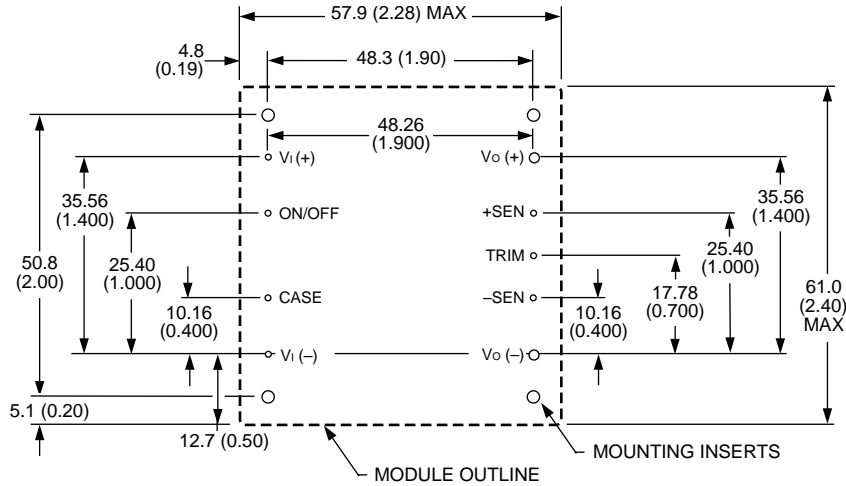

8-1190 (C).g

Ordering Information

Table 4. Device Codes

| Input Voltage | Output Voltage | Output Power | Device Code | Comcode |
|---------------|----------------|--------------|-------------|-----------|
| 48 V | 5 V | 75 W | JW075A5 | 107743262 |
| 48 V | 12 V | 75 W | JW075B5 | 107743304 |
| 48 V | 15 V | 75 W | JW075C5 | 108092693 |

Ordering Information (continued)

Table 5. Device Accessories

| Accessory | Comcode |
|---|-----------|
| 1/4 in. transverse kit (heat sink, thermal pad, and screws) | 407243989 |
| 1/4 in. longitudinal kit (heat sink, thermal pad, and screws) | 407243997 |
| 1/2 in. transverse kit (heat sink, thermal pad, and screws) | 407244706 |
| 1/2 in. longitudinal kit (heat sink, thermal pad, and screws) | 407244714 |
| 1 in. transverse kit (heat sink, thermal pad, and screws) | 407244722 |
| 1 in. longitudinal kit (heat sink, thermal pad, and screws) | 407244730 |
| 1 1/2 in. transverse kit (heat sink, thermal pad, and screws) | 407244748 |
| 1 1/2 in. longitudinal kit (heat sink, thermal pad, and screws) | 407244755 |

Dimensions are in millimeters and (inches).

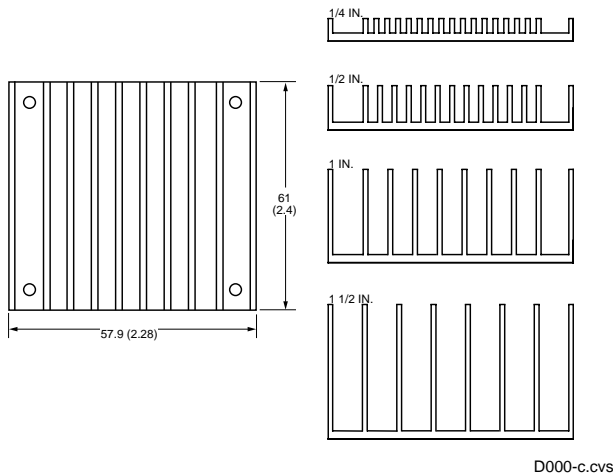

Figure 29. Longitudinal Heat Sink

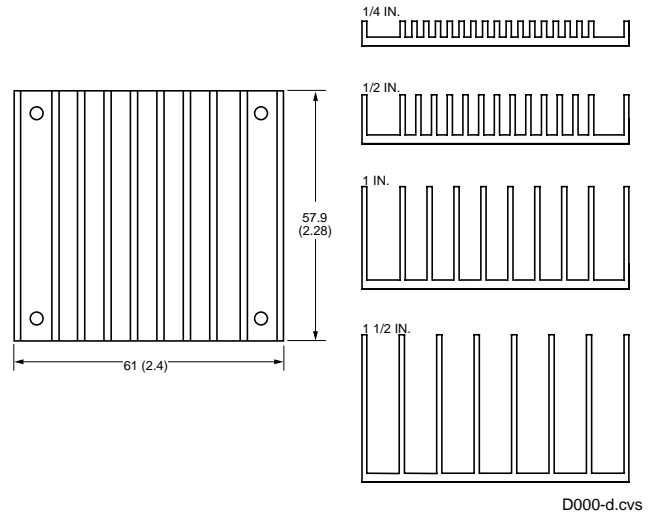

Figure 30. Transverse Heat Sink



LINEAGE POWER

World Wide Headquarters

Lineage Power Corporation

3000 Skyline Drive, Mesquite, TX 75149, USA

+1-800-526-7819

(Outside U.S.A.: **+1-972-284-2626**)

www.lineagepower.com

e-mail: techsupport1@lineagepower.com

Asia-Pacific Headquarters

Tel: +65 6416 4283

Europe, Middle-East and Africa Headquarters

Tel: +49 89 6089 286

India Headquarters

Tel: +91 80 28411633

Lineage Power reserves the right to make changes to the product(s) or information contained herein without notice. No liability is assumed as a result of their use or application. No rights under any patent accompany the sale of any such product(s) or information.

© 2008 Lineage Power Corporation, (Mesquite, Texas) All International Rights Reserved.

April 2008

DS99-289EPS (Replaces DS97-086EPS)