

ULTRAFast RECTIFIER PDP ENERGY RECOVERY

Table 1: Main Product Characteristics

$I_{F(AV)}$	60 A
V_{RRM}	300 V
$V_{FP} (typ)$	2.5 V
$I_{RM} (typ)$	6 A
T_j	175°C
$V_F (typ)$	0.9 V

FEATURES AND BENEFITS

- Ultrafast recovery allowing High Sustain Frequency
- Decrease charge evacuation time in the inductance (see figure 1)
- Minimize switching-on and total power losses
- Increase luminous efficiency and brightness
- Soft and noise-free recovery
- High surge capability
- High junction temperature

DESCRIPTION

The **STTH60P03SW** is an Ultrafast Recovery Power Rectifier dedicated to **energy recovery in PDP application**.

The key parameters of the D_{ERC} diode for the energy recovery circuit have been optimized in order to decrease power losses.

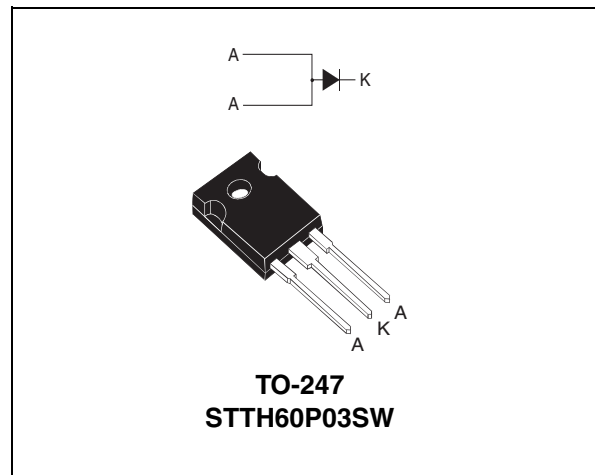

Table 2: Order Code

Part Number	Marking
STTH60P03SW	STTH60P03SW

Table 3: Absolute Ratings (limiting values)

Symbol	Parameter		Value	Unit
V_{RRM}	Repetitive peak reverse voltage		300	V
$I_{F(RMS)}$	RMS forward current		80	A
$I_{F(AV)}$	Average forward current		60	A
I_{FSM}	Surge non repetitive forward current	$t_p = 10ms$ sinusoidal	250	A
I_{FRM}	Forward repetitive peak surge current	$F = 200 kHz, t_p = 500 ns$ Sinusoidal waveform, $T_c = 155°C$	150	A
T_{stg}	Storage temperature range		-65 to + 175	°C
T_j	Maximum operating junction temperature		175	°C

STTH60P03S

Table 4: Thermal Parameters

Symbol	Parameter	Value	Unit
$R_{th(j-c)}$	Junction to case	0.8	°C/W
$Z_{th(j-c)}$	Transient thermal resistance at 1μs	0.002	°C/W

Table 5: Static Electrical Characteristics

Symbol	Parameter	Test conditions		Min.	Typ	Max.	Unit
I_R^*	Reverse leakage current	$T_j = 25^\circ\text{C}$	$V_R = V_{RRM}$			100	μA
		$T_j = 125^\circ\text{C}$			0.1	1	mA
V_F^{**}	Forward voltage drop	$T_j = 25^\circ\text{C}$	$I_F = 30\text{A}$			1.5	V
		$T_j = 125^\circ\text{C}$			0.9	1.15	

Pulse test: * $t_p = 5\text{ ms}$, $\delta < 2\%$
 ** $t_p = 380\text{ μs}$, $\delta < 2\%$

To evaluate the conduction losses use the following equation: $P = 0.88 \times I_{F(AV)} + 0.009 I_F^2 (RMS)$

Table 6: Switching Characteristics

Symbol	Parameter	Test conditions		Min.	Typ	Max.	Unit
I_{RM}	Reverse recovery current	$T_j = 100^\circ\text{C}$	$I_F = 60\text{A}$ $V_R = 100\text{V}$ $di_F/dt = 200\text{ A/μs}$		6	7.5	A
S_{factor}	Softness factor				0.5		
V_{FP}	Peak forward voltage	$T_j = 25^\circ\text{C}$	$I_F = 60\text{A}$ $di_F/dt = 400\text{ A/μs}$		2.5	3.5	V

Figure 1: Application Characteristics

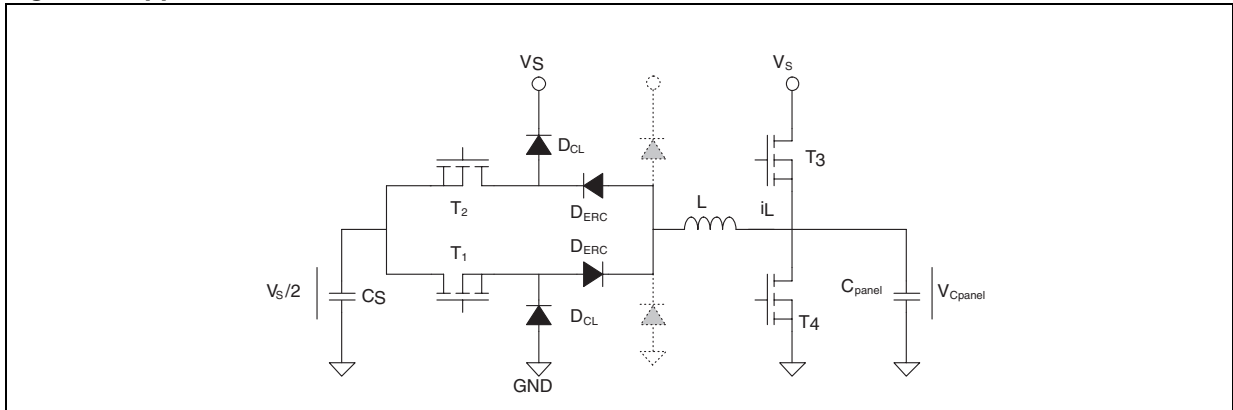

Figure 2: Application Waveforms

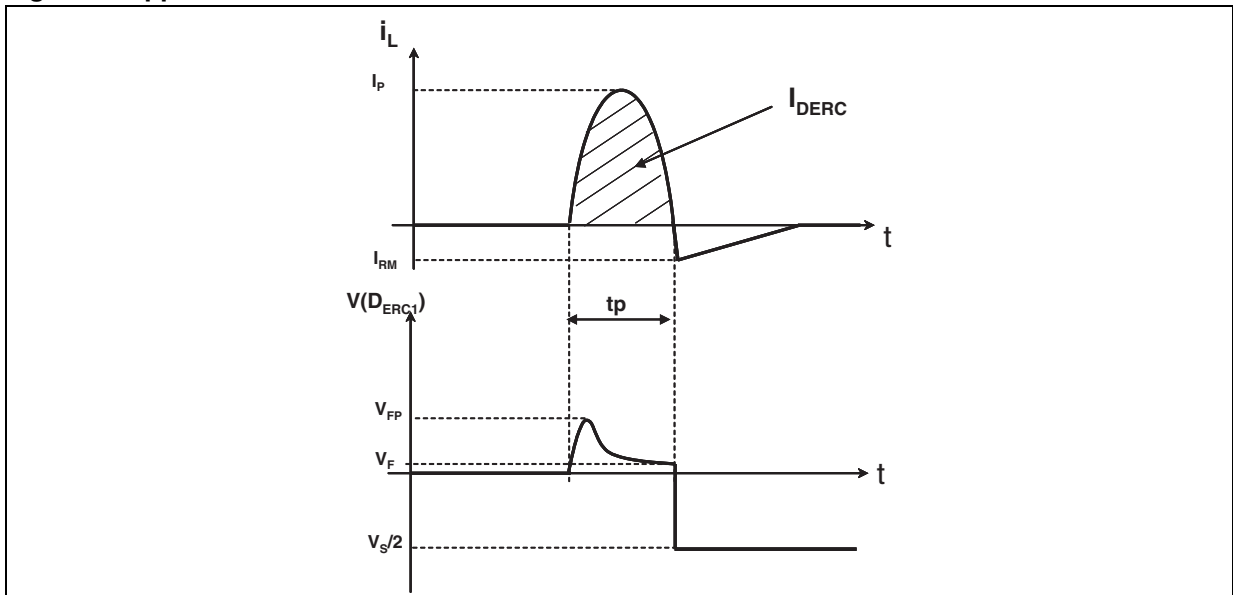

Figure 3: Forward voltage drop versus forward current

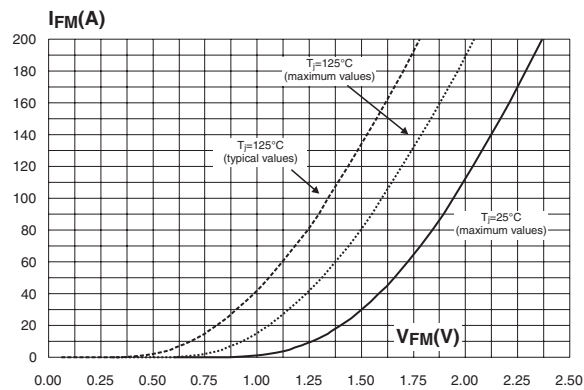

Figure 4: Relative variation of thermal impedance junction to case versus pulse duration

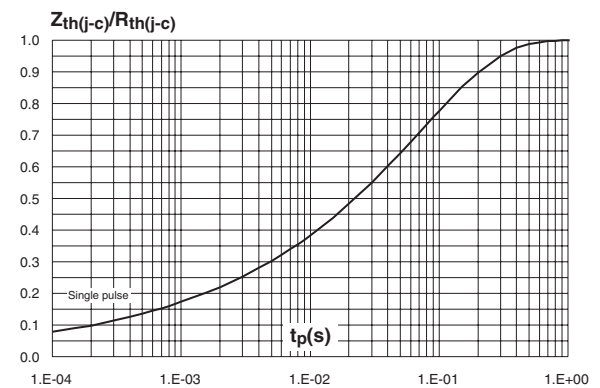

Figure 5: Peak reverse recovery current versus di_F/dt (typical values)

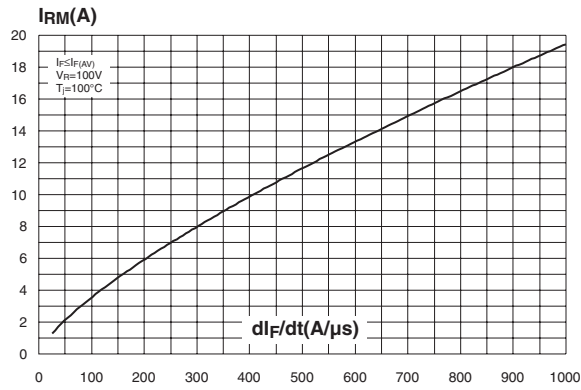

Figure 6: Reverse recovery time versus di_F/dt (typical values)

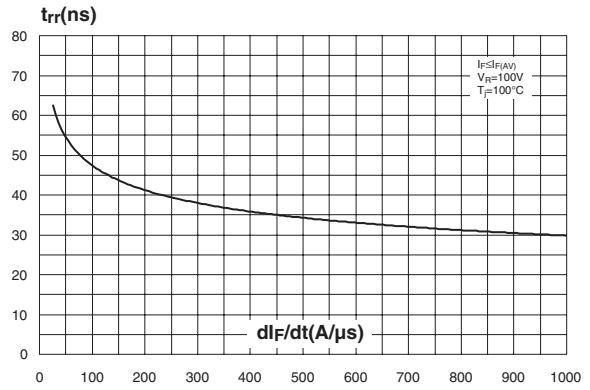

Figure 7: Reverse recovery softness factor versus di_F/dt (typical values)

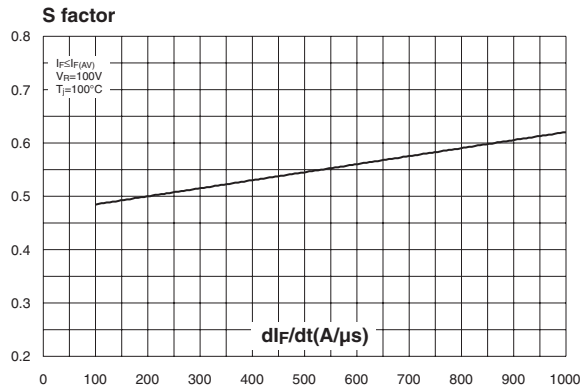

Figure 8: Relative variations of dynamic parameters versus junction temperature

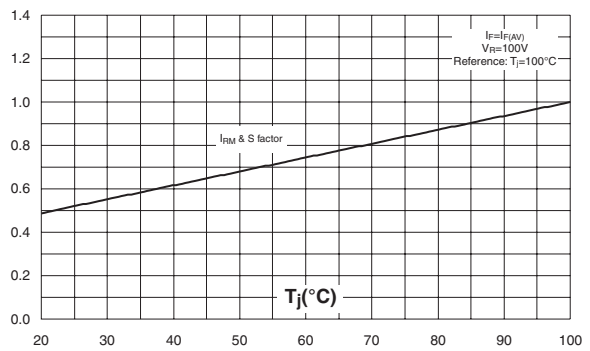

Figure 9: Transient peak forward voltage versus di_F/dt (typical values)

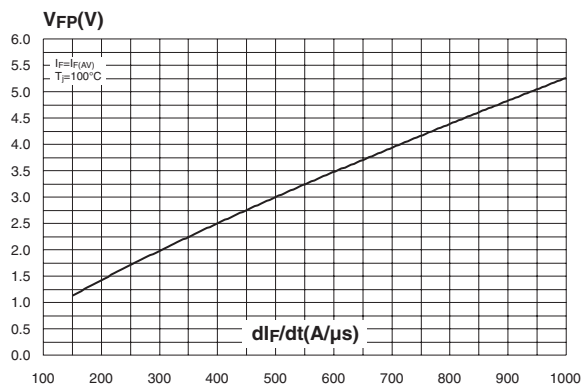

Figure 10: Forward recovery time versus di_F/dt (typical values)

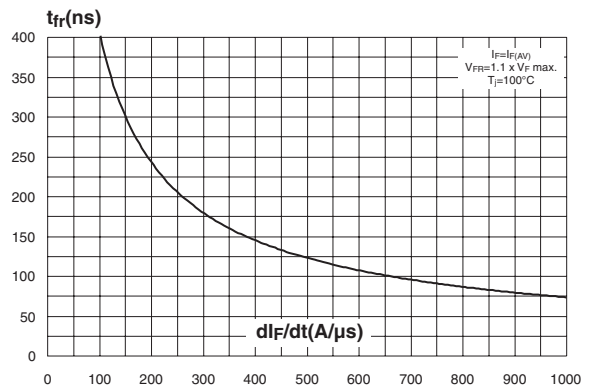

Figure 11: TO-247 Package Mechanical Data

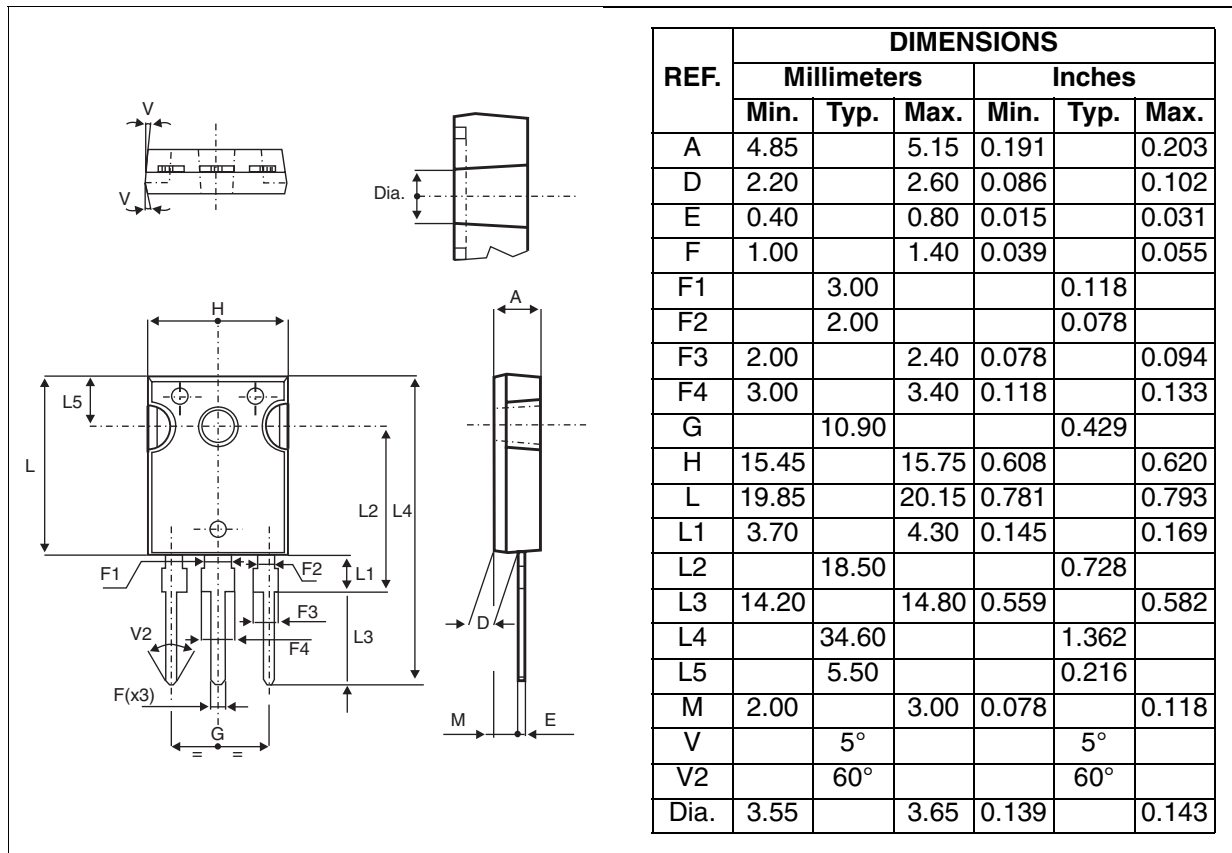

Table 7: Ordering Information

Ordering type	Marking	Package	Weight	Base qty	Delivery mode
STTH60P03SW	STTH60P03SW	TO-247	4.46 g	30	Tube

- Epoxy meets UL94, V0
- Cooling method: by conduction (C)
- Recommended torque value: 0.8 m.N.
- Maximum torque value: 1.0 m.N.

Table 8: Revision History

Date	Revision	Description of Changes
04-Nov-2004	1	First issue.
10-Jan-2005	2	Minor layout update. No content change.
04-03-2005	3	Table 7 on page 5: base quantity delivery from 50 to 30.

Information furnished is believed to be accurate and reliable. However, STMicroelectronics assumes no responsibility for the consequences of use of such information nor for any infringement of patents or other rights of third parties which may result from its use. No license is granted by implication or otherwise under any patent or patent rights of STMicroelectronics. Specifications mentioned in this publication are subject to change without notice. This publication supersedes and replaces all information previously supplied. STMicroelectronics products are not authorized for use as critical components in life support devices or systems without express written approval of STMicroelectronics.

The ST logo is a registered trademark of STMicroelectronics.
All other names are the property of their respective owners

© 2005 STMicroelectronics - All rights reserved

STMicroelectronics group of companies

Australia - Belgium - Brazil - Canada - China - Czech Republic - Finland - France - Germany - Hong Kong - India - Israel - Italy - Japan -
Malaysia - Malta - Morocco - Singapore - Spain - Sweden - Switzerland - United Kingdom - United States of America

www.st.com