

Features

- Bluetooth radio
 - Fully embedded Bluetooth® v3.0 with profiles
 - Class 1 module
 - Complete RF ready module
 - 128-bit encryption security
 - Range up to 60 m LOS
 - Integrated antenna
 - Multipoint capability
- ST Micro Cortex-M3 microprocessor up to 72 MHz
- Memory
 - 256 kB Flash memory
 - 48 kB RAM memory
- Data rate
 - 1.5 Mbps maximum data rate
- Serial interface
 - UART up to 2.0 Mbps
 - SPI interface
- General I/O
 - 16 general purpose I/Os
- User interface
 - AT2 command set (abSerial)
 - Firmware upgrade over UART
- FCC and Bluetooth® qualified
- EPL (end product listing) fulfilled
- Single voltage supply: 2.5 V typical
- Small form factor: 15 x 27 x 2.9 mm
- Operating temperature range: -40 °C to 85 °C

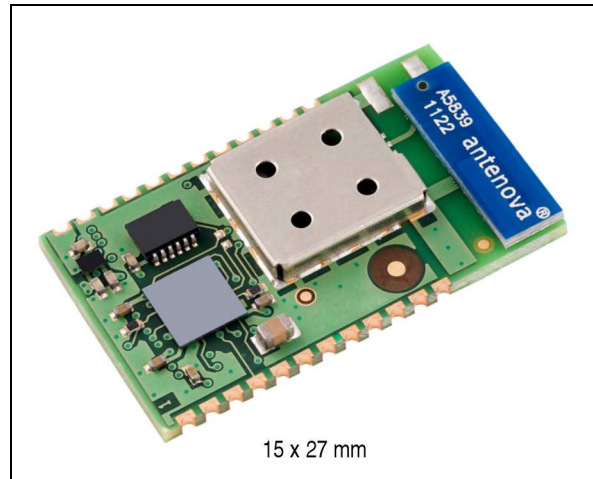

Contents

- 1 Description 6**
- 2 RoHS compliance 7**
- 3 Applications 7**
- 4 Software architecture 8**
 - 4.1 Lower layer stack 8
 - 4.2 Upper layer stack: Amp'ed UP 8
 - 4.3 AT command set: abSerial 8
 - 4.4 Bluetooth firmware implantation 9
- 5 Hardware specifications 10**
 - 5.1 Recommended operating conditions 10
 - 5.2 Absolute maximum ratings 10
 - 5.3 High speed mode CPU current consumption 10
 - 5.4 Standard CPU mode current consumption 11
 - 5.5 I/O operating characteristics 11
 - 5.6 Selected RF characteristics 12
 - 5.7 Pin assignment 12
 - 5.8 Pin placement 14
 - 5.9 Layout drawing 14
- 6 Hardware block diagram 15**
- 7 Hardware design 16**
 - 7.1 Module reflow installation 16
 - 7.2 GPIO interface 17
 - 7.3 UART interface 17
 - 7.4 PCB layout guidelines 18
 - 7.5 Reset circuit 19
 - 7.5.1 External reset circuit 19
 - 7.5.2 Internal reset circuit 19



7.6	Apple iOS CP reference design	20
8	Regulatory compliance	22
9	Ordering information	24
10	Revision history	25

List of tables

Table 1.	Recommended operating conditions	10
Table 2.	Absolute maximum ratings	10
Table 3.	Current consumption	10
Table 4.	Standard CPU mode current consumption	11
Table 5.	I/O operating characteristics	11
Table 6.	Selected RF characteristics	12
Table 7.	Pin assignment	12
Table 8.	Soldering	16
Table 9.	Ordering information	24
Table 10.	Document revision history	25

List of figures

Figure 1.	FW architecture	9
Figure 2.	Pin placement	14
Figure 3.	Layout drawing	14
Figure 4.	SPBT2632C1A.AT2 module block diagram	15
Figure 5.	Soldering profile	17
Figure 6.	Connection to host device	17
Figure 7.	Typical RS232 circuit	18
Figure 8.	PCB layout guidelines.	18
Figure 9.	External reset circuit	19
Figure 10.	Internal reset circuit	19
Figure 11.	BT module	20
Figure 12.	Co-processor	20
Figure 13.	Power switch.	21

1 Description

The SPBT2632C1A.AT2 is an easy to use Bluetooth module, compliant with Bluetooth v3.0. The module provides complete RF platform in a small form factor.

The SPBT2632C1A.AT2 enables electronic devices with wireless connectivity, not requiring any RF experience or expertise for integration into the final product. The SPBT2632C1A.AT2 module, being a certified solution, optimizes the time to market of the final application.

The module is designed for maximum performance in a minimal space including fast speed UART and 16 general purpose I/O lines, several serial interface options, and up to 1.5 Mbps data throughput.

An optimized design allows the integration of a complete working Bluetooth modem, including antenna and LPO (low power oscillator), enabling low power mode capability in the minimum possible size.

The SPBT2632C1A.AT2 is a surface mount PCB module that provides fully embedded, ready-to-use Bluetooth wireless technology. The reprogrammable Flash memory contains embedded firmware for serial cable replacement using the Bluetooth SPP profile.

Embedded Bluetooth AT2 command firmware is a friendly interface, which realizes a simple control for cable replacement, enabling communication with most Bluetooth enabled devices, provided that the devices support SPP profile. The SPBT2532C1A.AT2, supporting iAP profile, provides communication with Android, smartphone and Apple® iOS Bluetooth enabled devices. An Apple authentication IC is required to exchange data with an Apple device or access an Apple device application. The AT2 FW includes the Bluetooth SPP profile capable of recognizing the Apple authentication chip.

Customers using the Apple authentication IC must register as developers, to become an Apple certified MFI member. License fees may apply, for additional information visit: <http://developer.apple.com/programs/which-program/index.html>.

Certified MFI developers developing electronic accessories that connect to an iPod®, iPhone®, and iPad® can gain access to technical documentation, hardware components, technical support and certification logos.

Customized firmware for peripheral device interaction, power optimization, security, and other proprietary features may be supported and can be ordered pre-loaded and configured.

2 RoHS compliance

ST modules are RoHS compliant and comply with ECOPACK® norms.

3 Applications

- Serial cable replacement
- M2M industrial control
- Service diagnostics
- Data acquisition equipment
- Machine controls
- Sensor monitoring
- Security systems
- Mobile health.

4 Software architecture

4.1 Lower layer stack

- Bluetooth v3.0
- Device power active, sleep and deep sleep
- Wake on Bluetooth feature optimized power consumption of host CPU
- Authentication and encryption
- Encryption key length from 8 bits to 128 bits
- Persistent Flash memory for BD address and radio parameter storage
- All ACL (asynchronous connection less) packet types
- Multipoint capability
- Sniff mode: fully supported to maximum allowed intervals
- Master slave switch supported during connection and post connection
- Dedicated inquiry access code for improved inquiry scan performance
- Dynamic packet selection channel quality driven data rate to optimize link performance
- Dynamic power control
- 802.11b co-existence AFH.

4.2 Upper layer stack: Amp'ed UP

- SPP, IAP, SDAP and GAP protocols
- RFCOMM, SDP and L2CAP supported
- Multipoint with simultaneous slaves.

4.3 AT command set: abSerial

- Please see command list reported in the SPBT2532C2.AT datasheet, Appendix D, for details.
- The complete command list including the iAP commands will be reported in the user manual UM1547

4.4 Bluetooth firmware implantation

Figure 1. FW architecture

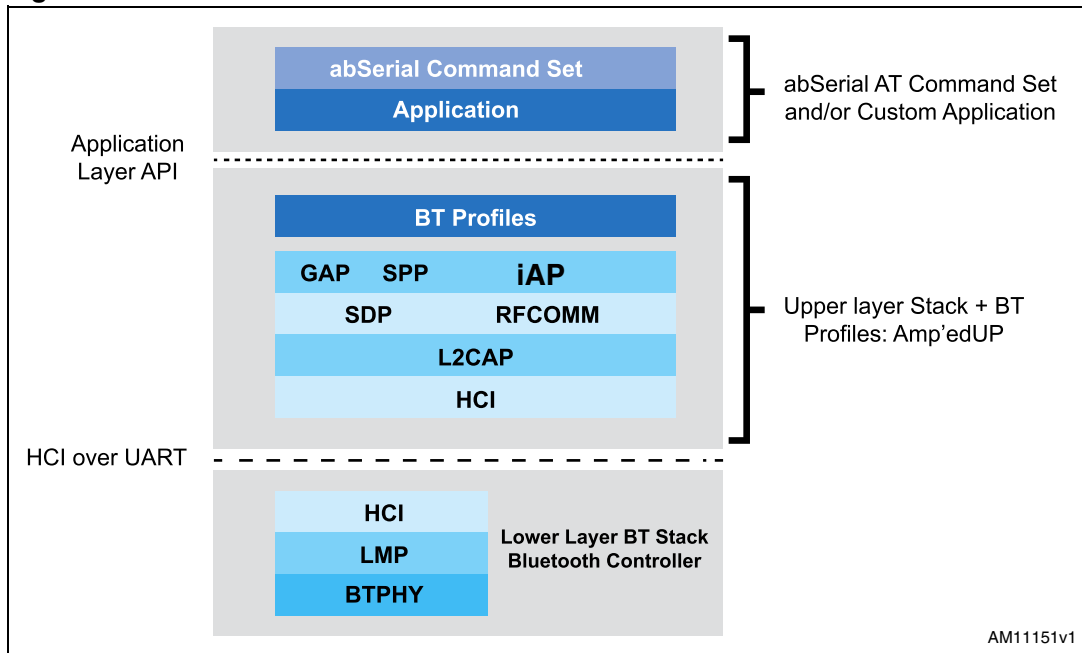

5 Hardware specifications

General conditions ($V_{IN}= 2.5$ V and 25 °C).

5.1 Recommended operating conditions

Table 1. Recommended operating conditions

Rating	Min.	Typ.	Max.	Unit
Operating temperature range	-40	-	85	°C
Supply voltage V_{IN}	2.0	2.5	3.6	V
Signal pin voltage	-	2.1	-	V
RF frequency	2400	-	2483.5	MHz

5.2 Absolute maximum ratings

Table 2. Absolute maximum ratings

Rating	Min.	Typ.	Max.	Unit
Storage temperature range	-55	-	+105	°C
Supply voltage, V_{IN}	-0.3	-	+ 5.0	V
I/O pin voltage, V_{IO}	-0.3	-	+ 5.5	V
RF input power	-	-	-5	dBm

5.3 High speed mode CPU current consumption

- High speed CPU mode current consumption
 - CPU 32 MHz
 - UART supports up to 921 Kbps
 - Data throughput up to 1.5 Mbps
 - Shallow sleep enabled

Table 3. Current consumption

Modes (typical power consumption)	Avg	Unit
ACL data 115 K Baud UART at max. throughput (master)	23	mA
ACL data 115 K Baud UART at max. throughput (slave)	27.5	mA
Connection, no data traffic, master	9.1	mA
Connection, no data traffic, slave	11.2	mA
Connection in sniff ($T_{sniff}=375$ ms), no data traffic, master	490	μA

Table 3. Current consumption (continued)

Modes (typical power consumption)	Avg	Unit
Standby, without deep sleep	8.6	mA
Standby, with deep sleep	60	μA
Page/inquiry scan, deep sleep	520	μA
Bluetooth power-down / CPU standby	6	μA

5.4 Standard CPU mode current consumption

- High speed CPU mode
 - CPU 8 MHz
 - UART supports up to 115 Kbps
 - Data throughput up to 200 Kbps
 - Shallow sleep enabled

Table 4. Standard CPU mode current consumption

Modes (typical power consumption)	Avg.	Unit
ACL data 115 K Baud UART at max. throughput (master)	16.7	mA
ACL data 115 K Baud UART at max. throughput (slave)	18	mA
Connection, no data traffic, master	4.9	mA
Connection, no data traffic, slave	7.0	mA
Connection in sniff (Tsniff=375 ms), no data traffic, master	490	μA
Standby, without deep sleep	4.2	mA
Standby, with deep sleep	60	μA
Page/Inquiry scan, deep sleep	520	μA
Bluetooth power-down / CPU standby	6	μA

5.5 I/O operating characteristics

Table 5. I/O operating characteristics

Symbol	Parameter	Min.	Max.	Unit	Conditions
V _{IL}	Low level input voltage	-	0.6	V	V _{IN} , 2.1 V
V _{IH}	High level input voltage	1.4	-	V	V _{IN} , 2.1 V
V _{OL}	Low level output voltage	-	0.4	V	V _{IN} , 2.1 V
V _{OH}	High level output voltage	1.8	-	V	V _{IN} , 2.1 V
I _{OL}	Low level output current	-	4.0	mA	V _{OL} = 0.4 V
I _{OH}	High level output current	-	4.0	mA	V _{OH} = 1.8 V

Table 5. I/O operating characteristics (continued)

Symbol	Parameter	Min.	Max.	Unit	Conditions
R _{PU}	Pull-up resistor	80	120	kΩ	Resistor turned on
R _{PD}	Pull-down resistor	80	120	kΩ	Resistor turned on

5.6 Selected RF characteristics

Table 6. Selected RF characteristics

Parameters	Conditions	Typical ⁽¹⁾	Unit
Antenna load		50	ohm
Radio receiver			
Sensitivity level	BER < .001 with DH5	-90	dBm
Maximum usable level	BER < .001 with DH1	0	dBm
Input VSWR		2.5:1	
Radio transmitter			
Maximum output power	50 Ω load	+10	dBm
Initial carrier frequency tolerance		0	kHz
20 dB bandwidth for modulated carrier		±5	kHz

1. RF characteristics can be influenced by physical characteristics of final application

5.7 Pin assignment

Table 7. Pin assignment

Name	Type	Pin #	Description	ALT function ⁽¹⁾	5 V tolerant
UART interface					
RXD	I	8	Receive data		Y
TXD	O	6	Transmit data		Y
CTS	I	9	Clear to send (active low)		Y
RTS	O	10	Request to send (active low)		Y
Boot loader					
Boot 0	I	2	Reserved		
Power and ground					
V _{DD}		24	V _{DD}		
GND		23	GND		

Table 7. Pin assignment (continued)

Name	Type	Pin #	Description	ALT function ⁽¹⁾	5 V tolerant
Reset					
RESETN	I	3	Reset input (active low for 5 ms)		2.5 Vmax
GPIO - general purpose input/output					
GPIO [0]	I/O	16	General purpose input/output	SPI MISO	Y
GPIO [1]	I/O	17	General purpose input/output	SPI MOSI	Y
GPIO [2]	I/O	19	General purpose input/output	SPI SS	Y
GPIO [3]	I/O	1	General purpose input/output	SPI CLK	Y
GPIO [4]	I/O	18	General purpose input/output	UART 2 RXD	Y
GPIO [5]	I/O	20	General purpose input/output	UART 2 TXD	Y
GPIO [6]	I/O	22	General purpose input/output	ADC 0	2.5 Vmax
GPIO [7]	I/O	13	General purpose input/output	ADC 1	2.5 Vmax
GPIO [8]	I/O	4	General purpose input/output	ADC 2	2.5 Vmax
GPIO [9]	I/O	7	General purpose input/output	ADC 3	2.5 Vmax
GPIO [10]	I/O	5	General purpose input/output		Y
GPIO [11]	I/O	11	General purpose input/output	I2C SCL	Y
GPIO [12]	I/O	12	General purpose input/output	I2C SDA	Y
GPIO [13]	I/O	15	General purpose input/output		Y
GPIO [14]	I/O	14	General purpose input/output		Y
GPIO [15]	I/O	21	General purpose input/output	DAC	2.5 Vmax

1. Please note that the usage of ALT function is dependant upon the firmware that is loaded into the module, and is beyond the scope of this document. The AT command interface uses the main UART by default.

5.8 Pin placement

Figure 2. Pin placement

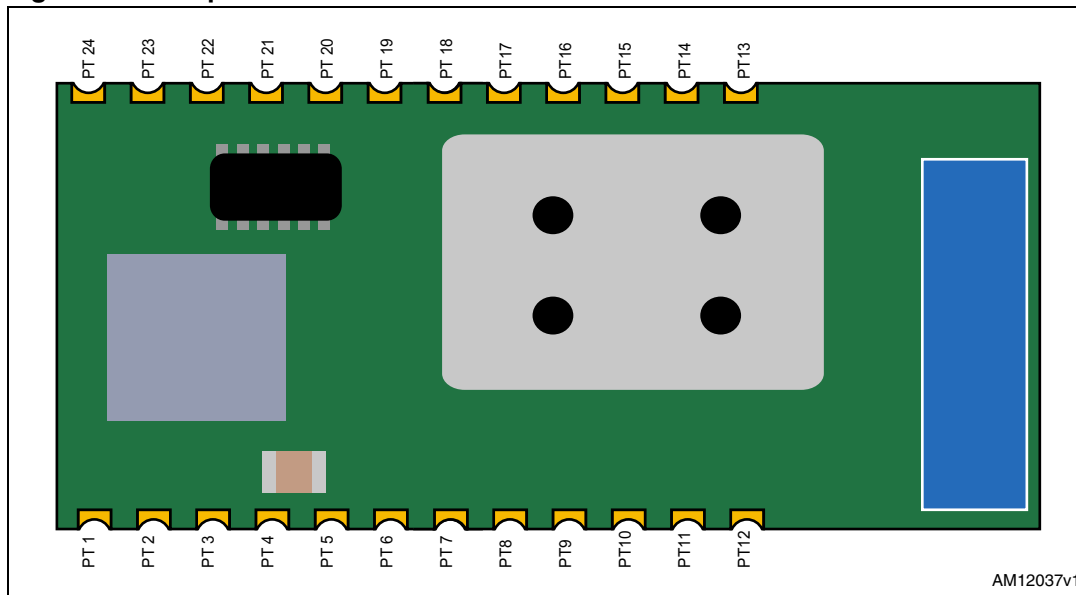

AM12037v1

5.9 Layout drawing

Figure 3. Layout drawing

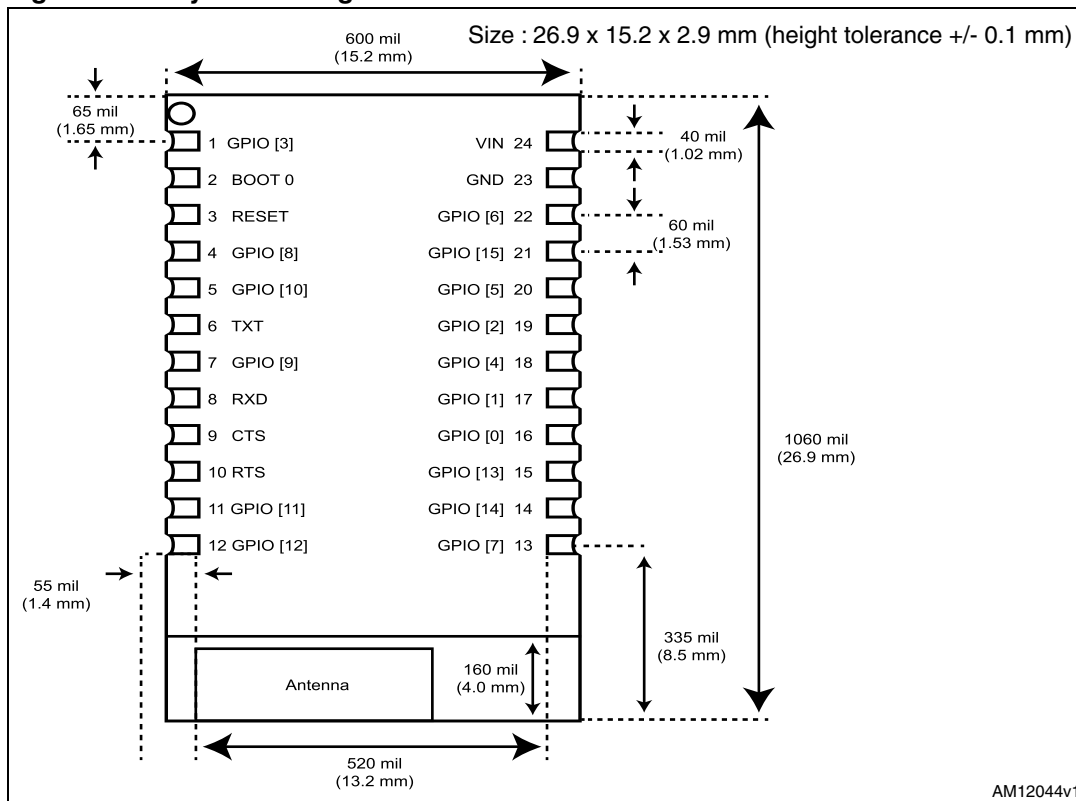

AM12044v1

6 Hardware block diagram

Figure 4. SPBT2632C1A.AT2 module block diagram

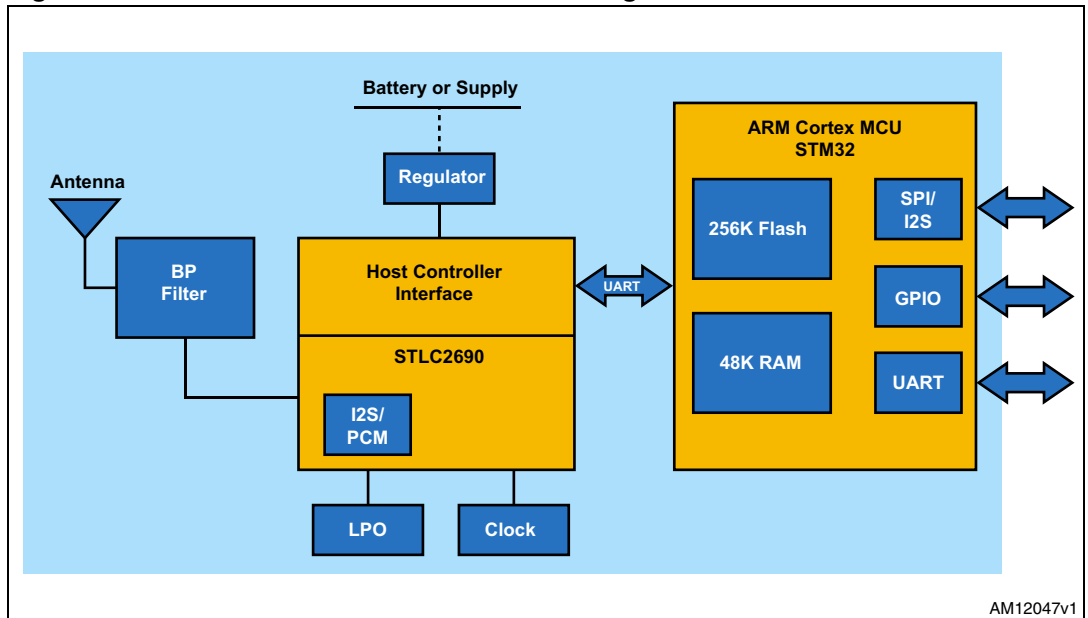

7 Hardware design

The SPBT2632C1A module without AT2 command embedded FW, supports UART, SPI, I²C and GPIO hardware interfaces. Note that the use of these interfaces is dependant upon the firmware that is loaded into the module, and is beyond the scope of this document. The AT2 command interface uses the main UART by default.

- Note:*
- 1 All unused pins should be left floating; do not ground.
 - 2 All GND pins must be well grounded.
 - 3 The area around the module should be free of any ground planes, power planes, trace routings, or metal for 6 mm from the antenna in all directions.
 - 4 Traces should not be routed underneath the module.

7.1 Module reflow installation

The SPB2632C1A is a surface mount Bluetooth module supplied on a 24-pin, 6-layer PCB. The final assembly recommended reflow profiles are indicated here below.

The soldering phase must be executed with care: In order to avoid undesired melting phenomenon, particular attention must be paid to the set-up of the peak temperature.

[Table 8](#) contains some suggestions for the temperature profile based on IPC/JEDEC J-STD-020C, July 2004 recommendations.

Table 8. Soldering

Profile feature	PB-free assembly
Average ramp-up rate (T _S MAX to T _P)	3 °C/sec max.
Preheat:	
– Temperature min. (T _S min.)	150 °C
– Temperature max. (T _S max.)	200 °C
– Time (t _S min. to t _S max.)(t _S)	60-100 sec
Time maintained above:	
– Temperature T _L	217 °C
– Temperature T _L	60-70 sec
Peak temperature (T _P)	240 + 0 °C
Time within 5 °C of actual peak temperature (T _P)	10-20 sec
Ramp-down rate	6 °C/sec
Time from 25 °C to peak temperature	8 minutes max.

Figure 5. Soldering profile

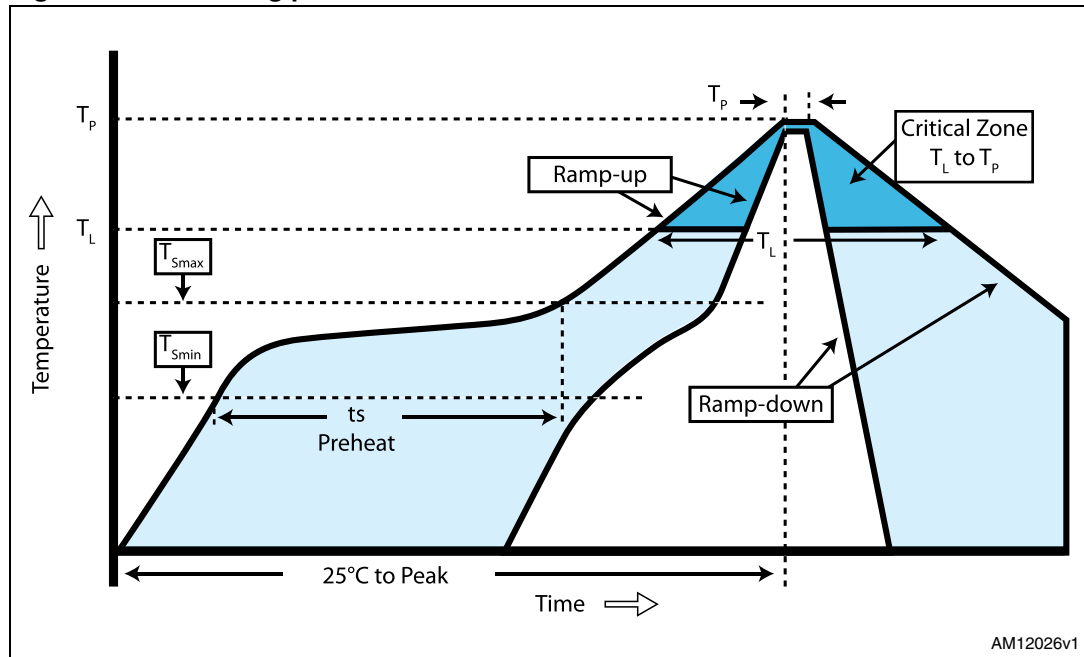

AM12026v1

7.2 GPIO interface

All GPIOs are capable of sinking and sourcing 8 mA of I/O current. GPIO [0] to GPIO [7] are internally pulled down with 100 kΩ (nominal) resistors, GPIO [8] to GPIO [15] are internally pulled up with 100 kΩ (nominal) resistors.

7.3 UART interface

The UART is compatible with the 16550 industry standard. Four signals are provided with the UART interface. The TXD and RXD pins are used for data while the CTS and RTS pins are used for flow control.

Figure 6. Connection to host device

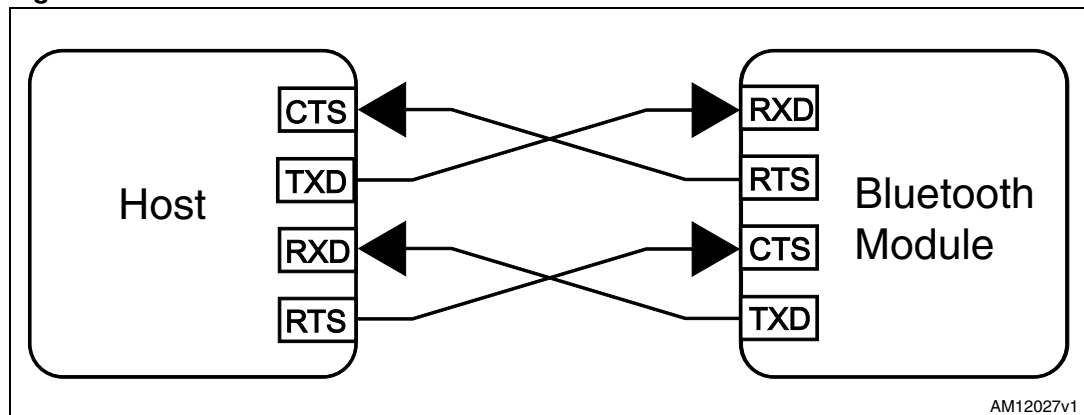

AM12027v1

Figure 7. Typical RS232 circuit

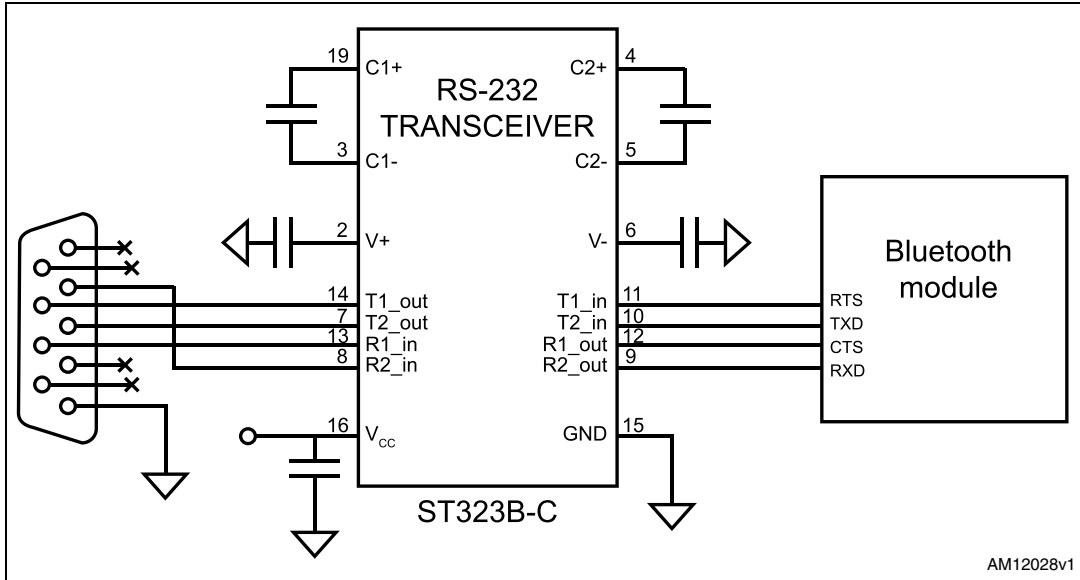

7.4 PCB layout guidelines

Figure 8. PCB layout guidelines

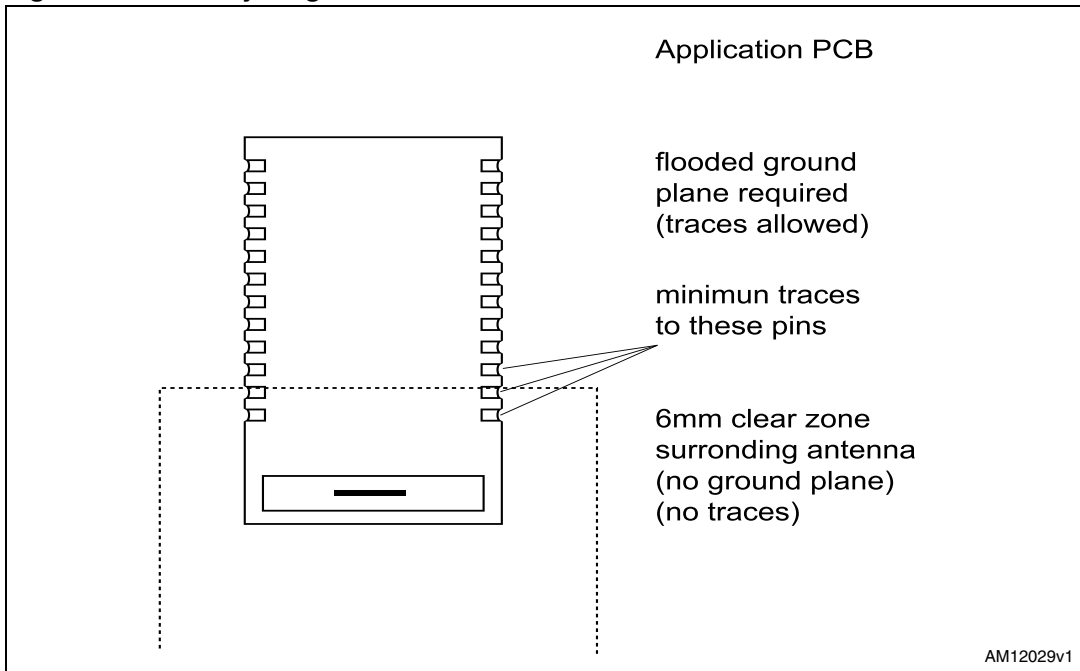

7.5 Reset circuit

Two types of system reset circuits are detailed below.

7.5.1 External reset circuit

Figure 9. External reset circuit

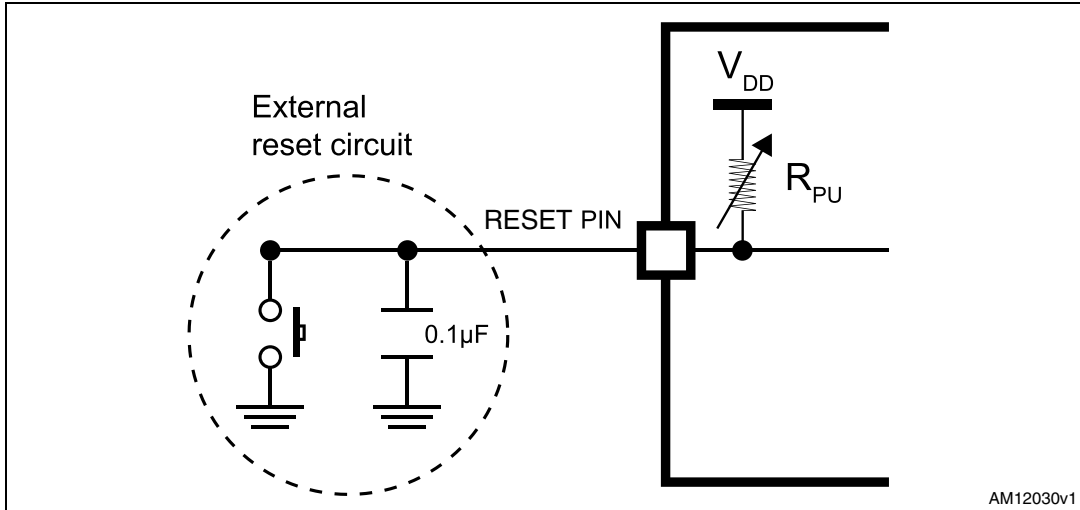

Note: R_{PU} ranges from 30 k Ω to 50 k Ω internally.

7.5.2 Internal reset circuit

Figure 10. Internal reset circuit

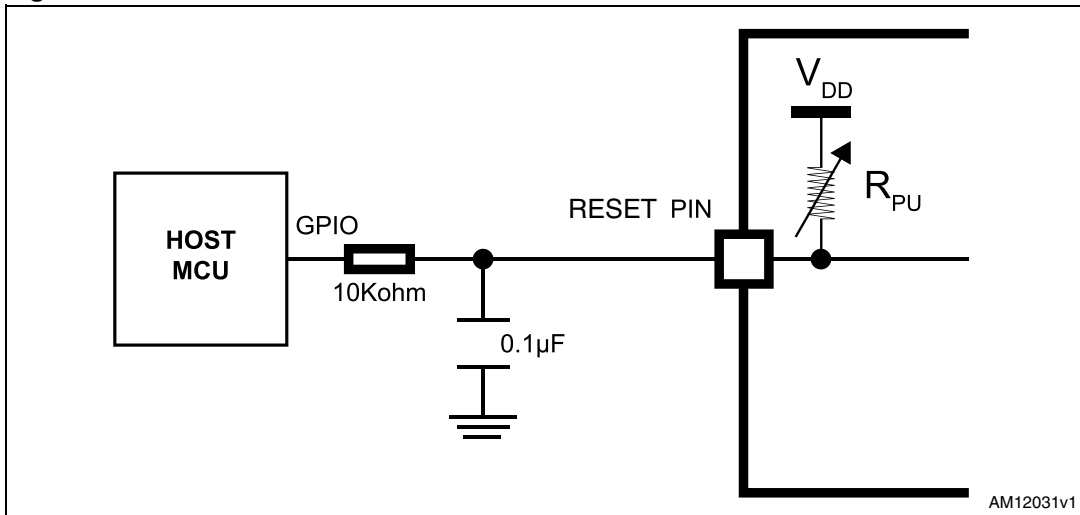

- Note:
- 1 R_{PU} ranges from 30 k Ω to 50 k Ω internally.
 - 2 R_{RST} should be from 1 k Ω to 10 k Ω

7.6 Apple iOS CP reference design

The figures below give an indicative overview of what the hardware concept looks like. A specific MFI co-processor layout is available for licensed MFI developers from the MFI program.

Figure 11. BT module

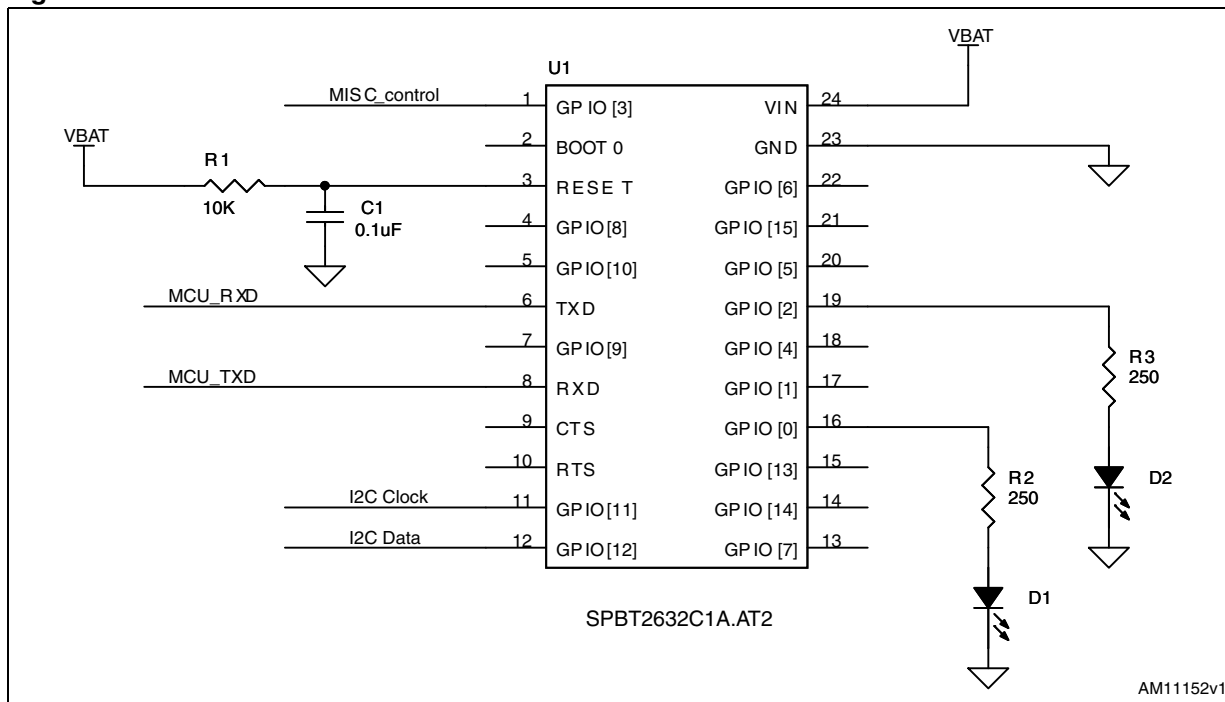

Figure 12. Co-processor

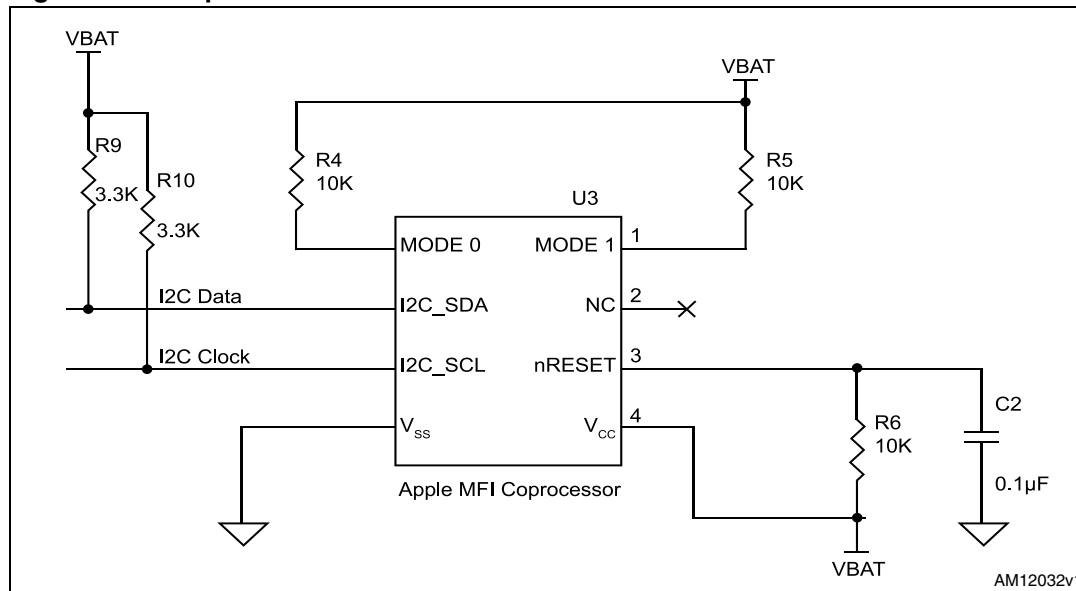
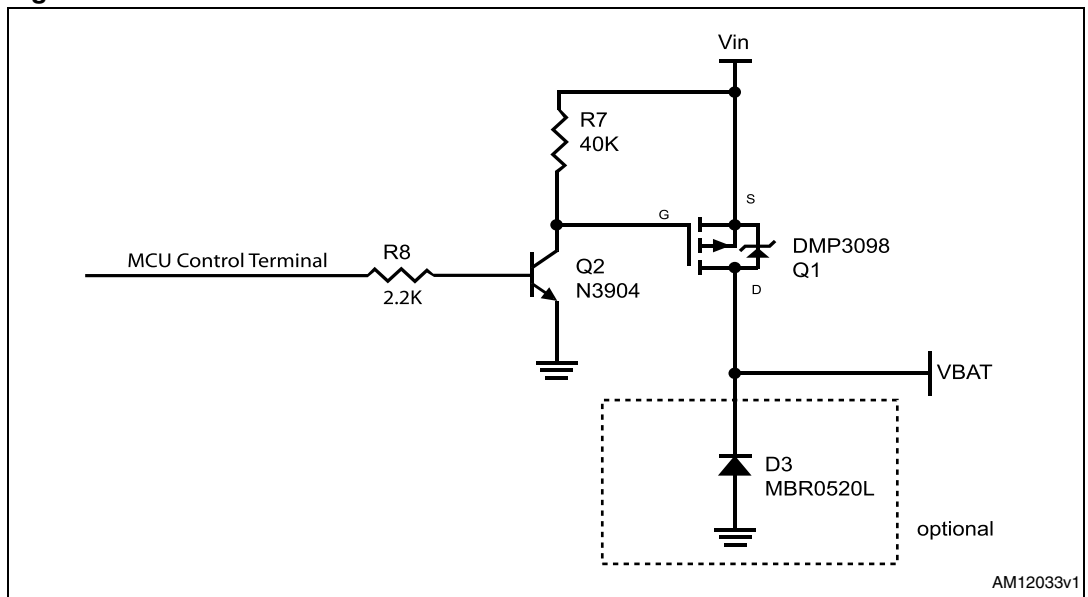

Figure 13. Power switch



8 Regulatory compliance

- FCC and IC
 - This module has been tested and found to comply with the FCC part 15 and IC RSS-210 rules. These limits are designed to provide reasonable protection against harmful interference in approved installations. This equipment generates, uses, and can radiate radio frequency energy and, if not installed and used in accordance with the instructions, may cause harmful interference to radio communications. However, there is no guarantee that interference may not occur in a particular installation. This device complies with part 15 of the FCC rules. Operation is subject to the following two conditions: (1) this device may not cause harmful interference, and (2) this device must accept any interference received, including interference that may cause undesired operation.
Modifications or changes to this equipment not expressly approved by the part responsible for compliance may render void the user's authority to operate this equipment.
 - Modular Approval, FCC and IC
FCC ID: X3ZBTMOD3
IC: 8828A-MOD3
In accordance with FCC part 15, the SPT2632C1A.AT2 is listed above as a modular transmitter device.
 - Label instructions:
When integrating the SPBT2632C1A.AT2 into the final product, it must be ensured that the FCC labelling requirements, as specified below, are satisfied. Based on the public notice from FCC, the product into which the ST transmitter module is installed must display a label referring to the enclosed module.
The label should use wording such as the following:
Contains transmitter module
FCC ID: X3ZBTMOD3
IC: 8828A-MOD3
Any similar wording that expresses the same meaning may be used.
- BQB
 - BQB qualified design, QD ID: B019224
 - Product type: End Product
 - TGP version: Core 3.0
 - Core spec version: 3.0
 - Product descriptions: Bluetooth module, spec V3.0

- CE
 - CE Expert opinion: 0447-ARAM00002
 - Measurements have been performed in accordance with (report available on request):
 - EN 300 328 V 1.7.1 (2006-10) ^(a)
 - EN 301 489-17 V 2.1.1 (2009) ^(b)
 - EN60950-1:2006 +A11:2009+A1:2010 ^(c)
- CE certified:

CE0051 

-
- a. EN 300 328 V 1.7.1 (2006-10): “electromagnetic compatibility and radio spectrum Matters (ERM); Wideband transmission systems; data transmission equipment operating in the 2.4 GHz ISM band and using wideband modulation techniques; harmonized EN covering essential requirements under article 3.2 of the R&TTE directive”.
 - b. EN 301 489-17 V 2.1.1 (2009): “electromagnetic compatibility and radio spectrum Matters (ERM); electromagnetic compatibility (EMC) standard for radio equipment and services; part 17: specific condition for 2.4 GHz wideband transmission systems and 5 GHz high performance RLAN equipment”.
 - c. EN60950-1:2006 +A11:2009+A1:2010: “Information technology equipment - safety”.

9 Ordering information

Table 9. Ordering information

Order code	Description
SPBT2632C1A.AT2	Class 1 OEM Bluetooth antenna module

10 Revision history

Table 10. Document revision history

Date	Revision	Changes
23-Apr-2012	1	Initial release.
12-Jun-2012	2	– Document status promoted from preliminary data to production data – Modified: Figure 1
07-Aug-2012	3	– Added: notes in Table 6 and 7 – Modified: Section 7

Please Read Carefully:

Information in this document is provided solely in connection with ST products. STMicroelectronics NV and its subsidiaries ("ST") reserve the right to make changes, corrections, modifications or improvements, to this document, and the products and services described herein at any time, without notice.

All ST products are sold pursuant to ST's terms and conditions of sale.

Purchasers are solely responsible for the choice, selection and use of the ST products and services described herein, and ST assumes no liability whatsoever relating to the choice, selection or use of the ST products and services described herein.

No license, express or implied, by estoppel or otherwise, to any intellectual property rights is granted under this document. If any part of this document refers to any third party products or services it shall not be deemed a license grant by ST for the use of such third party products or services, or any intellectual property contained therein or considered as a warranty covering the use in any manner whatsoever of such third party products or services or any intellectual property contained therein.

UNLESS OTHERWISE SET FORTH IN ST'S TERMS AND CONDITIONS OF SALE ST DISCLAIMS ANY EXPRESS OR IMPLIED WARRANTY WITH RESPECT TO THE USE AND/OR SALE OF ST PRODUCTS INCLUDING WITHOUT LIMITATION IMPLIED WARRANTIES OF MERCHANTABILITY, FITNESS FOR A PARTICULAR PURPOSE (AND THEIR EQUIVALENTS UNDER THE LAWS OF ANY JURISDICTION), OR INFRINGEMENT OF ANY PATENT, COPYRIGHT OR OTHER INTELLECTUAL PROPERTY RIGHT.

UNLESS EXPRESSLY APPROVED IN WRITING BY TWO AUTHORIZED ST REPRESENTATIVES, ST PRODUCTS ARE NOT RECOMMENDED, AUTHORIZED OR WARRANTED FOR USE IN MILITARY, AIR CRAFT, SPACE, LIFE SAVING, OR LIFE SUSTAINING APPLICATIONS, NOR IN PRODUCTS OR SYSTEMS WHERE FAILURE OR MALFUNCTION MAY RESULT IN PERSONAL INJURY, DEATH, OR SEVERE PROPERTY OR ENVIRONMENTAL DAMAGE. ST PRODUCTS WHICH ARE NOT SPECIFIED AS "AUTOMOTIVE GRADE" MAY ONLY BE USED IN AUTOMOTIVE APPLICATIONS AT USER'S OWN RISK.

Resale of ST products with provisions different from the statements and/or technical features set forth in this document shall immediately void any warranty granted by ST for the ST product or service described herein and shall not create or extend in any manner whatsoever, any liability of ST.

ST and the ST logo are trademarks or registered trademarks of ST in various countries.

Information in this document supersedes and replaces all information previously supplied.

The ST logo is a registered trademark of STMicroelectronics. All other names are the property of their respective owners.

© 2012 STMicroelectronics - All rights reserved

STMicroelectronics group of companies

Australia - Belgium - Brazil - Canada - China - Czech Republic - Finland - France - Germany - Hong Kong - India - Israel - Italy - Japan - Malaysia - Malta - Morocco - Philippines - Singapore - Spain - Sweden - Switzerland - United Kingdom - United States of America

www.st.com