



# SPZB260C-PRO

## Low-power, compact ZigBee® module

### Features

- Integrated 2.4 GHz, IEEE 802.15.4 compliant transceiver:
  - + 3 dBm nominal TX output power (at UFL connector level)
  - + 5 dBm in boost mode
  - -95 dBm (typ) RX sensitivity
  - RX filtering for co-existence with IEEE 802.11g and Bluetooth® devices
  - Integrated VCP and loop filter
- SPI or UART interface available for connection with a host processor
- On-board 24 MHz stable Xtal
- Operates in the -40 °C to +85 °C industrial temperature range
- 1 µA power consumption in deep sleep mode
- Pins available for non-intrusive debug interface (SIF)
- Single supply voltage (2.1 V to 3.6 V)
- Integrated RF UFL connector for external antenna
- CE and RoHS compliant
- FCC compliant (FCC ID: S9NZB260B)

### Applications

- Industrial control
- Sensor networking
- Monitoring of remote systems
- Home appliances
- Security systems
- Lighting control
- Metering



### Description

The SPZB260C-PRO is a low power, compact ZigBee® module optimized for embedded applications. It enables OEMs to easily add wireless capability to electronic devices.

The module is based on the EM260 ZigBee network processor, which integrates a 2.4 GHz IEEE 802.15.4 compliant transceiver and IEEE 802.15.4 PHY and MAC.

A single supply voltage is required to power the module. The voltage supply also determines the I/O port level, allowing easy integration with the target device. The module integrates an RF UFL connector, allowing the use of an external antenna.

The EM260 provides an SPI-based serial interface (EZSP - EmberZNet serial protocol) or UART interface to the EmberZNet APIs, both accessible from the module.

The module is shipped with the EmberZnet PRO version 3.3.1 loaded into the Flash memory for use of the SPI-based serial interface.

For details or additional information, please refer to the EM260 datasheet available on the Ember Corporation website.

# Contents

- 1      Block diagram ..... 3**
- 2      Pin information ..... 4**
  - 2.1 Pin connections ..... 4
  - 2.2 Pin description ..... 5
- 3      Maximum ratings ..... 6**
  - 3.1 Absolute maximum ratings ..... 6
  - 3.2 Operating ranges ..... 6
- 4      Electrical characteristics ..... 7**
  - 4.1 DC electrical characteristics ..... 7
  - 4.2 DC I/O specifications ..... 7
  - 4.3 RF electrical characteristics ..... 8
- 5      Package mechanical dimensions ..... 9**
- 6      Soldering ..... 11**
- Appendix A    FCC statement ..... 12**
  - A.1 Instructions for FCC ID labeling ..... 12
  - A.2 Special requirement for modular application ..... 13
- Revision history ..... 14**

# 1 Block diagram

Figure 1. SPZB260C-PRO block diagram

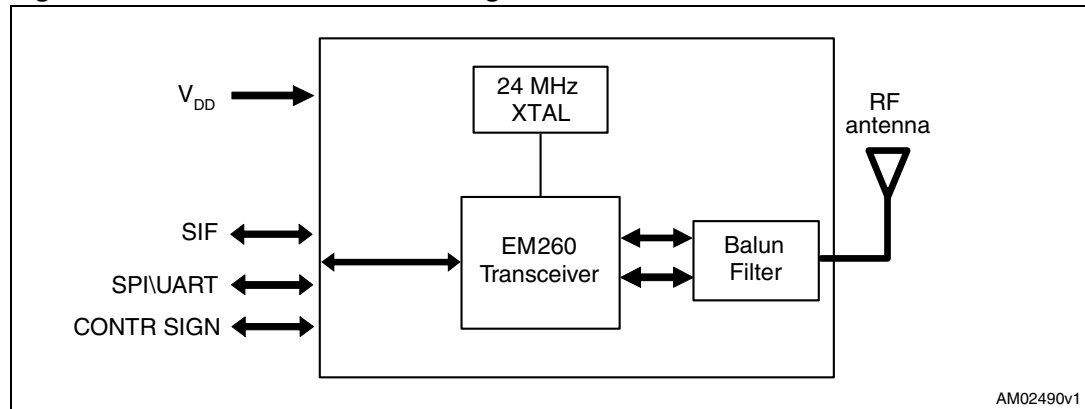

## 2 Pin information

### 2.1 Pin connections

Figure 2. Pin connection diagram

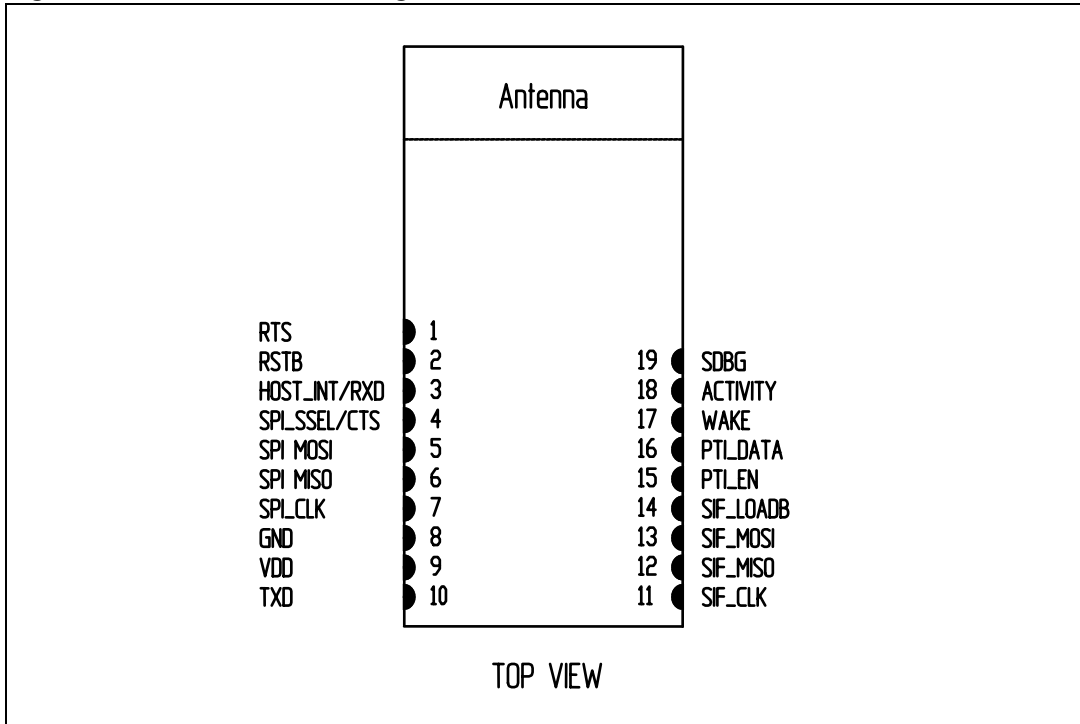

## 2.2 Pin description

Table 1. Pin description

Pin n	Pin name	Direction	Description	
			SPI mode	UART mode
1	RTS	O	Not used	RTS signal (10 kΩ pull-up to VDD)
2	RSTB	I	Active low reset (a pull-up of 10 kΩ typ is provided with 10 nF to GND)	
3	HOST_INT / RXD	O / I	Host interrupt signal (from ZB module to host) - SPI mode	RXD signal
4	SPI_SSEL / CTS	I	SPI slave select (from host to ZB module)	CTS signal
5	SPI MOSI	I	SPI data, master out/slave in (from host to ZB module)	Not used
6	SPI MISO	O	SPI data, master in/slave out (from ZB module to host)	Not used
7	SPI_CLK	I	SPI clock	Not used
8	GND	---	Ground	
9	VDD	---	Input power supply	
10	TXD	O	Not used	TXD signal (10 kΩ pull-up to VDD)
11	SIF_CLK	I	Non-intrusive debug interface. Serial interface clock signal (internal pull-down)	
12	SIF_MISO	O	Non-intrusive debug interface. Serial interface master in/slave out	
13	SIF_MOSI	I	Non-intrusive debug interface Serial interface master out/slave in To guarantee proper signal level when in deep sleep mode, a 10 kΩ resistor to GND is included	
14	SIF_LOADB	I/O	Non-intrusive debug Interface Serial interface load strobe (open collector with internal pull-up). To improve noise immunity, a 10 kΩ resistor to Vdd is included	
15	PTI_EN	O	Frame signal of packet trace interface (PTI)	
16	PTI_DATA	O	Data signal of packet trace interface (PTI)	
17	WAKE	I	Wake interrupt signal from host to ZB module	
18	ACTIVITY	O	Activity signal for application debug /monitor	
19	SDBG	O	Spare debug signal	

## 3 Maximum ratings

### 3.1 Absolute maximum ratings

Table 2. Absolute maximum ratings

Symbol	Parameter	Values		Unit
		Min.	Max.	
$V_{DD}$	Module supply voltage	-0.3	3.6	V
$V_{IN}$	Input voltage on any digital pin	-0.3	Vdd+0.3	V
$T_{stg}$	Storage temperature	-40	+85	°C
$T_{sold}$	Soldering temperature < 10 s		250	°C

### 3.2 Operating ranges

Table 3. Operating ranges

Symbol	Parameter	Conditions	Values			Unit
			Min.	Typ.	Max.	
$V_{DD}$	Module supply voltage	- 40 °C < T < 85 °C	2.1	3.3	3.6	V
$T_{stg}$	Operating ambient temperature		-40		+85	°C

## 4 Electrical characteristics

### 4.1 DC electrical characteristics

Table 4. DC electrical characteristics

Symbol	Parameter	Conditions	Values			Unit
			Min.	Typ.	Max.	
IRX	RX current (boost mode)	Vdd = 3.0 V, T = 25 °C	-	38		mA
IRX	RX current (normal mode)	Vdd = 3.0 V, T = 25 °C	-	36		mA
ITX	TX current (boost mode)	Vdd = 3.0 V, T = 25 °C	-	42		mA
ITX	TX current (normal mode)	Vdd = 3.0 V, T = 25 °C	-	36		mA
IDS	Deep sleep current	2.1 < Vdd < 3.6 V T = 25°C	-		1	μA

### 4.2 DC I/O specifications

Table 5. DC input/output specifications

Symbol	Parameter	Conditions	Values			Unit
			Min.	Typ.	Max.	
VIL	Low level input voltage	2.1 < Vdd < 3.6 V	0		0.2 x Vdd	V
VIH	High level input voltage	2.1 < Vdd < 3.6 V	0.8 x Vdd		Vdd	V
Iil	Input current for logic 0	2.1 < Vdd < 3.6 V			-0.5	mA
Iih	Input current for logic 1	2.1 < Vdd < 3.6 V			0.5	mA
Ripu	Input pull-up resistor			30		kΩ
Ripd	Input pull-down resistor			30		kΩ
VOL	Low level output voltage		0		0.18 x Vdd	V
VOH	High level output voltage		0.82 x Vdd		Vdd	V
IOHS	Output source current				4	mA
IOLS	Output sink current				4	mA
IOHH	Output source current (pin 15,16,17)				8	mA
IOLH	Output sink current (pin 15,16,17)				8	mA
IOTot	Total output current for I/O				40	mA

### 4.3 RF electrical characteristics

Table 6. RF electrical characteristics

Symbol	Parameter	Conditions	Values			Unit
			Min.	Typ.	Max.	
	Frequency range	$2.1 < V_{dd} < 3.6 \text{ V}$	2405		2480	MHz
TX	Output power	$V_{dd} = 3.0 \text{ V}$ , $F = 2450 \text{ MHz}$		3		dBm
RX	Sensitivity	$V_{dd} = 3.0 \text{ V}$ , 1% PER		-95		dBm
CFE	Carrier frequency error	$V_{dd} = 3.0 \text{ V}$ -20 / + 70 °C	-40		40	ppm

## 5 Package mechanical dimensions

In order to meet environmental requirements, ST offers these devices in different grades of ECOPACK® packages, depending on their level of environmental compliance. ECOPACK® specifications, grade definitions and product status are available at: [www.st.com](http://www.st.com). ECOPACK® is an ST trademark.

**Figure 3. Mechanical dimensions**

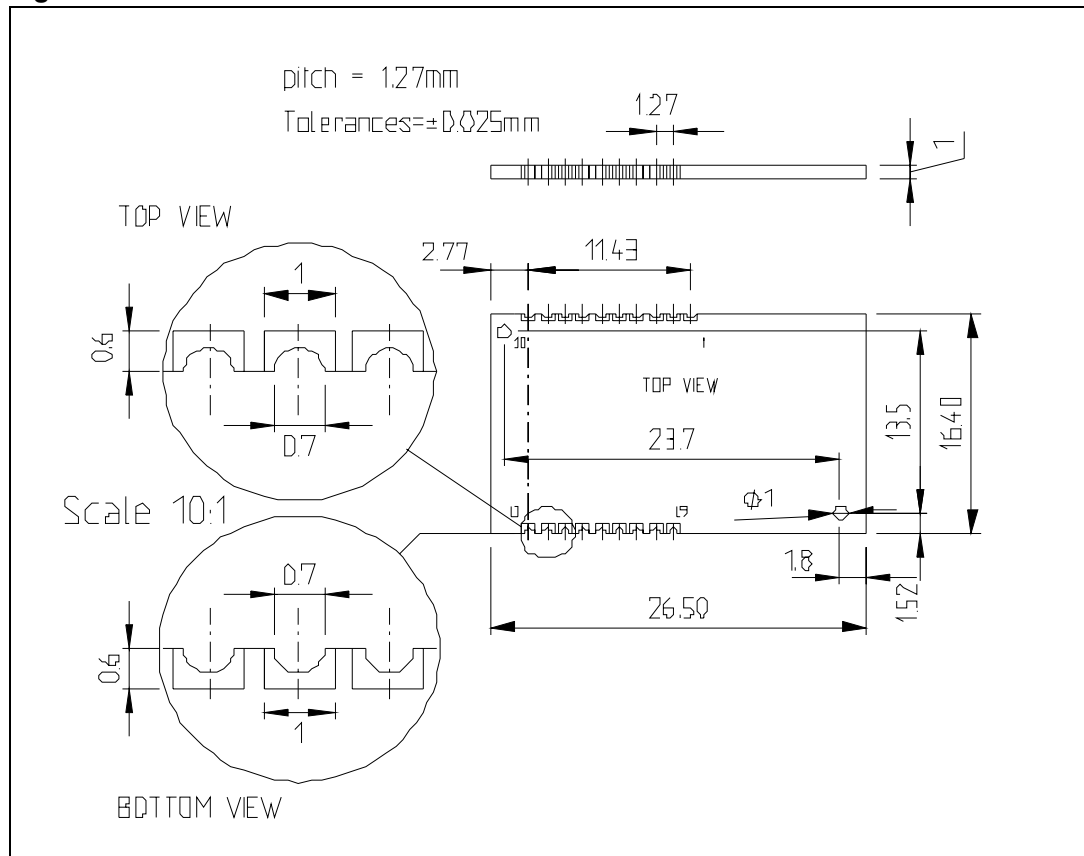
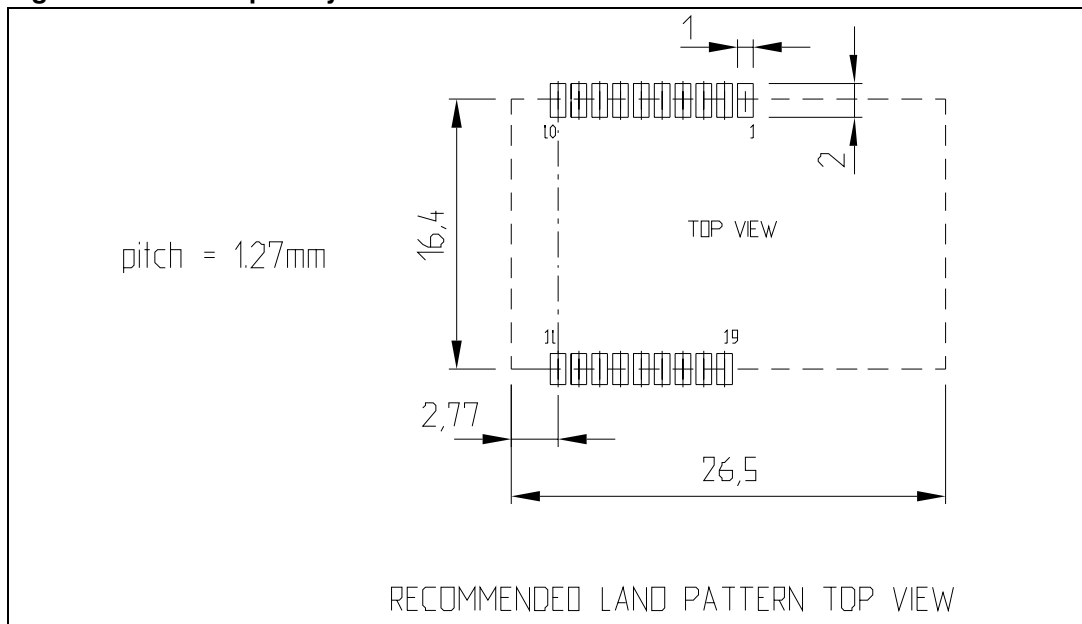

Figure 4. Solder pad layout



## 6 Soldering

Care should be taken during the soldering phase to avoid undesired melting, with particular attention on the peak temperature setting.

The following are some suggestions for the temperature profile based on IPC/JEDEC J-STD-020C, July 2004 recommendations.

**Table 7. Soldering profile**

Profile feature	PB free assembly
Average ramp up rate (TSMAX to TP)	3 °C / sec max
Preheating:	
Temperature min. (TS MIN)	150 °C
Temperature max. (TS MAX)	200 °C
Time (TS MIN to TS MAX) (ts)	60 – 100 sec
Time maintained above:	
Temperature TL	217 °C
Time tL	40 – 70 sec
Peak temperature (Tp)	240+0 °C
Time within 5 °C of actual peak temperature (tP)	10 – 20 sec
Ramp down rate	6 °C / sec
Time from 25 °C to peak temperature	8 minutes max

**Figure 5. Soldering**

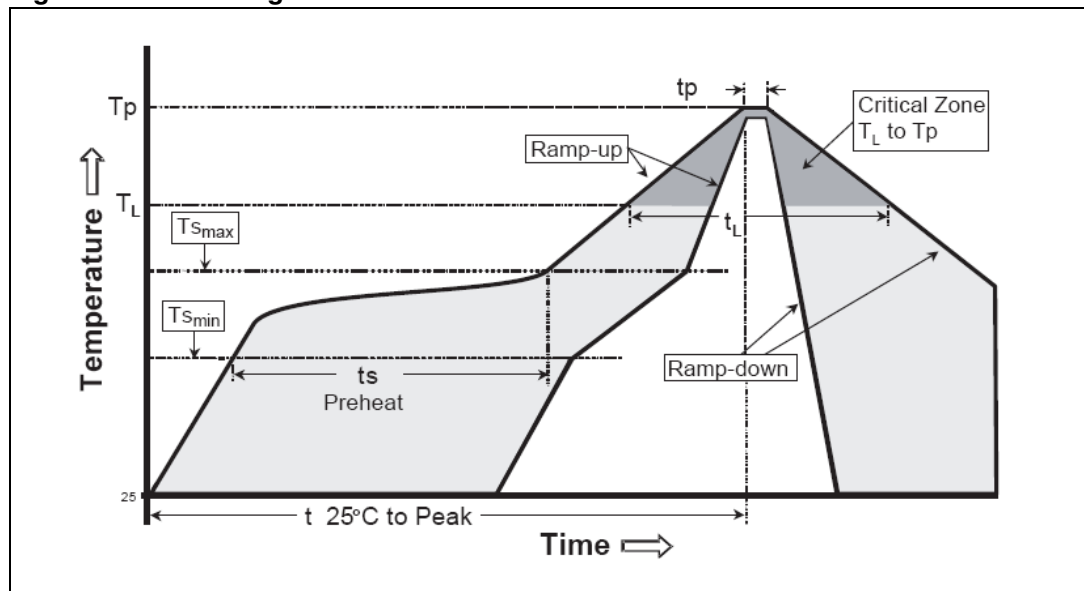

## Appendix A FCC statement

This device complies with part 15 of the FCC rules. Operation is subject to the following two conditions: (1) this device may not cause harmful interference, and (2) this device must accept any interference received, including interference that may cause undesired operation.

*Note: This equipment has been tested and found to comply with the limits for a class B digital device, pursuant to part 15 of the FCC rules. These limits are designed to provide reasonable protection against harmful interference in a residential installation. This equipment generates, uses and can radiate radio frequency energy and, if not installed and used in accordance with the instructions, may cause harmful interference to radio communications. However, there is no guarantee that interference will not occur in a particular installation. If this equipment does cause harmful interference to radio or television reception, which can be determined by turning the equipment off and on, the user is encouraged to try to correct the interference by one or more of the following measures:*

- Reorient or relocate the receiving antenna
- Increase the separation between the equipment and receiver
- Connect the equipment to an outlet on a circuit different from which the receiver is connected

Consult the dealer or an experienced radio/TV technician for assistance.

### Antenna

Module type SPZB260 is for OEM integration only. The end-user product must be professionally installed in such a manner that only the authorized antennas are used.

**Caution:** Changes or modifications not expressly approved by the party responsible for compliance may cause the module to cease to comply with part 15 of the FCC rules, thus voiding the user’s authorization to operate the equipment.

### A.1 Instructions for FCC ID labeling

Module type:                      ZigBee® module                      *SPZB260C-PRO*  
 FCC-ID:                              S9NZB260B

This is intended as a guideline for specifying the FCC ID of the ZigBee® module SPZB260C-PRO on the end product.

Based on the public notice from the FCC, the product into which this transmitter module is installed must display a label referring to the module.

The label should consist of wording such as “contains transmitter module FCC ID: S9NZB260B” or “contains FCC ID: S9NZB260B”, or any similar wording which conveys the same meaning.

For example:

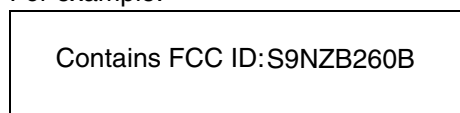

## A.2 Special requirement for modular application

The following requirements are fulfilled:

1. The modular transmitter must have its own RF shielding:  
The RF module used on the board fulfils the emission requirements of the relevant FCC rules without additional shielding.
2. The modular transmitter must have buffered modulation/data inputs:  
The module has a memory management unit integrated in the IC. The processor interfaces with the external application by means of general purpose I/O (GPIO), UART or SPI. The processor also interfaces with the RF part of the module, exchanging data and commands with it. Inside the processor, Flash memory is available to download the customer application and the ZigBee® profiles.
3. The modular transmitter must have its own power supply regulation:  
The IC contains a voltage regulation function. In case of changes in the supply voltage  $V_{CC}$  (due to temperature changes, for example), the internal voltage is stabilized.
4. The modular transmitter must comply with the antenna requirements of section 15.203 and 15.204:  
The RF module is for OEM (original equipment manufacturer) integration only. The end-user product must be professionally installed in such a manner that only the authorized antenna is used.
5. The modular transmitter must be tested in a stand-alone configuration:  
The RF module was tested in a stand-alone configuration.
6. The modular transmitter must be labelled with its own FCC ID number:  
The RF module must be labeled with its own FCC ID number. When the module is installed in the end-product, this label is not visible. The OEM manufacturer is instructed on how to apply an exterior label.
7. The modular transmitter must comply with any specific rules or operating requirements applicable to the transmitter, and the manufacturer must provide adequate instructions along with the module to explain any such requirements:  
The EUT is compliant with all applicable FCC rules. Detailed instructions are provided in the product's user guide.
8. The modular transmitter must comply with any applicable RF exposure requirements.
  - Maximum measured power output: 3.17 mW
  - Maximum antenna gain: 2.2 dBi = numeric gain 1.66 (also see FCC test report)

Maximum permissible exposure defined in 47 CFR 1.1310: 1 mW/cm<sup>2</sup>.

The RF module operates at a low power level which does not exceed the commission's RF exposure guideline limits. Moreover, spread spectrum transmitters operating according to section 15.247 are categorically excluded from routine environmental evaluation.

## Revision history

**Table 8. Document revision history**

Date	Revision	Changes
09-Sep-2010	1	First release.

**Please Read Carefully:**

Information in this document is provided solely in connection with ST products. STMicroelectronics NV and its subsidiaries ("ST") reserve the right to make changes, corrections, modifications or improvements, to this document, and the products and services described herein at any time, without notice.

All ST products are sold pursuant to ST's terms and conditions of sale.

Purchasers are solely responsible for the choice, selection and use of the ST products and services described herein, and ST assumes no liability whatsoever relating to the choice, selection or use of the ST products and services described herein.

No license, express or implied, by estoppel or otherwise, to any intellectual property rights is granted under this document. If any part of this document refers to any third party products or services it shall not be deemed a license grant by ST for the use of such third party products or services, or any intellectual property contained therein or considered as a warranty covering the use in any manner whatsoever of such third party products or services or any intellectual property contained therein.

**UNLESS OTHERWISE SET FORTH IN ST'S TERMS AND CONDITIONS OF SALE ST DISCLAIMS ANY EXPRESS OR IMPLIED WARRANTY WITH RESPECT TO THE USE AND/OR SALE OF ST PRODUCTS INCLUDING WITHOUT LIMITATION IMPLIED WARRANTIES OF MERCHANTABILITY, FITNESS FOR A PARTICULAR PURPOSE (AND THEIR EQUIVALENTS UNDER THE LAWS OF ANY JURISDICTION), OR INFRINGEMENT OF ANY PATENT, COPYRIGHT OR OTHER INTELLECTUAL PROPERTY RIGHT.**

**UNLESS EXPRESSLY APPROVED IN WRITING BY AN AUTHORIZED ST REPRESENTATIVE, ST PRODUCTS ARE NOT RECOMMENDED, AUTHORIZED OR WARRANTED FOR USE IN MILITARY, AIR CRAFT, SPACE, LIFE SAVING, OR LIFE SUSTAINING APPLICATIONS, NOR IN PRODUCTS OR SYSTEMS WHERE FAILURE OR MALFUNCTION MAY RESULT IN PERSONAL INJURY, DEATH, OR SEVERE PROPERTY OR ENVIRONMENTAL DAMAGE. ST PRODUCTS WHICH ARE NOT SPECIFIED AS "AUTOMOTIVE GRADE" MAY ONLY BE USED IN AUTOMOTIVE APPLICATIONS AT USER'S OWN RISK.**

Resale of ST products with provisions different from the statements and/or technical features set forth in this document shall immediately void any warranty granted by ST for the ST product or service described herein and shall not create or extend in any manner whatsoever, any liability of ST.

ST and the ST logo are trademarks or registered trademarks of ST in various countries.

Information in this document supersedes and replaces all information previously supplied.

The ST logo is a registered trademark of STMicroelectronics. All other names are the property of their respective owners.

© 2010 STMicroelectronics - All rights reserved

STMicroelectronics group of companies

Australia - Belgium - Brazil - Canada - China - Czech Republic - Finland - France - Germany - Hong Kong - India - Israel - Italy - Japan - Malaysia - Malta - Morocco - Philippines - Singapore - Spain - Sweden - Switzerland - United Kingdom - United States of America

[www.st.com](http://www.st.com)