



SPZB260-PRO

ZigBee® module

Features

- Integrated 2.4 GHz, IEEE 802.15.4-compliant transceiver:
 - 3 dBm nominal TX output power
 - -95 dBm RX sensitivity
 - + 5 dBm in boost mode
 - RX filtering for co-existence with IEEE 802.11g and Bluetooth devices
 - Integrated VCO and loop filter
- Integrated IEEE 802.15.4 PHY and MAC
- Controlled by a standard serial line for an easy interface of host microcontrollers (SPI)
- Embedded flash and integrated RAM for program and data storage
- On board 24 MHz stable crystal
- Integrated RC oscillator (typ. 10 kHz) for low power operation
- 1 μ A power consumption in deep sleep mode
- Watchdog timer and power-on reset
- Pins available for non-intrusive debug interface (SIF)
- Single supply voltage 2.1 to 3.6 Vdc
- Available link and activity outputs for external indication / monitor
- CE compliant ^(a)
- FCC compliant (FCC ID:S9NZB260A) ^(a)

Applications

- Industrial controls
- Sensor networking
- Monitoring of remote systems

a. SPZB260-PRO is based on the same unmodified HW of SPZB260 module.
The same certification statements apply.

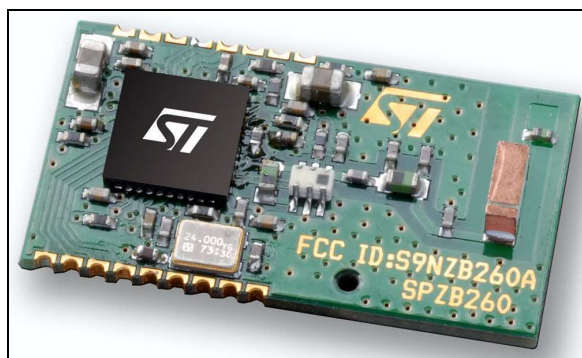

- Home applications
- Security systems
- Lighting controls

Description

SPZB260-PRO is a low power consumption ZigBee® module optimized for embedded applications. It enables OEMs to easily add wireless capability to electronic devices.

The module is based on SN260 ZigBee® network processor which integrates a 2.4 GHz, IEEE 802.15.4-compliant transceiver as well as IEEE 802.15.4 PHY and MAC.

24 MHz high stability crystal is integrated in the module to perform the timing requirements as per ZigBee® specifications.

A single supply voltage is requested to power the module. A 2.5 GHz specific Murata antenna is integrated in the module. The voltage supply determines the I/O ports level allowing an easy interface with the host system.

The module is controlled by means of a standard serial interface (SPI) allowing the connections to a variety of host microcontrollers.

For other information and details, please refer to SN260 datasheet available at www.st.com

Contents

- 1 Block diagram 3**
- 2 Pin settings 3**
 - 2.1 Pin connections 3
 - 2.2 Pin description 4
- 3 Maximum ratings 5**
 - 3.1 Absolute maximum ratings 5
 - 3.2 Operating ranges 5
- 4 Electrical characteristics 6**
 - 4.1 DC electrical characteristics 6
 - 4.2 DC I/O specification 6
 - 4.3 RF electrical characteristics 7
- 5 Package mechanical dimensions 8**
- 6 Soldering 10**
- Appendix A FCC statement 11**
 - A.1 Label instruction 12
 - A.2 Special requirement for modular application 12
- 7 Revision history 14**

1 Block diagram

Figure 1. Block diagram

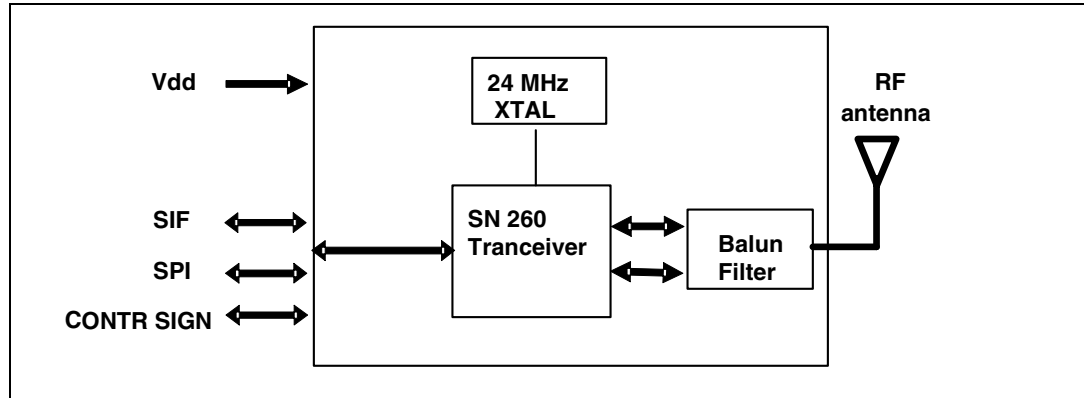

2 Pin settings

2.1 Pin connections

Figure 2. Pin connection diagram

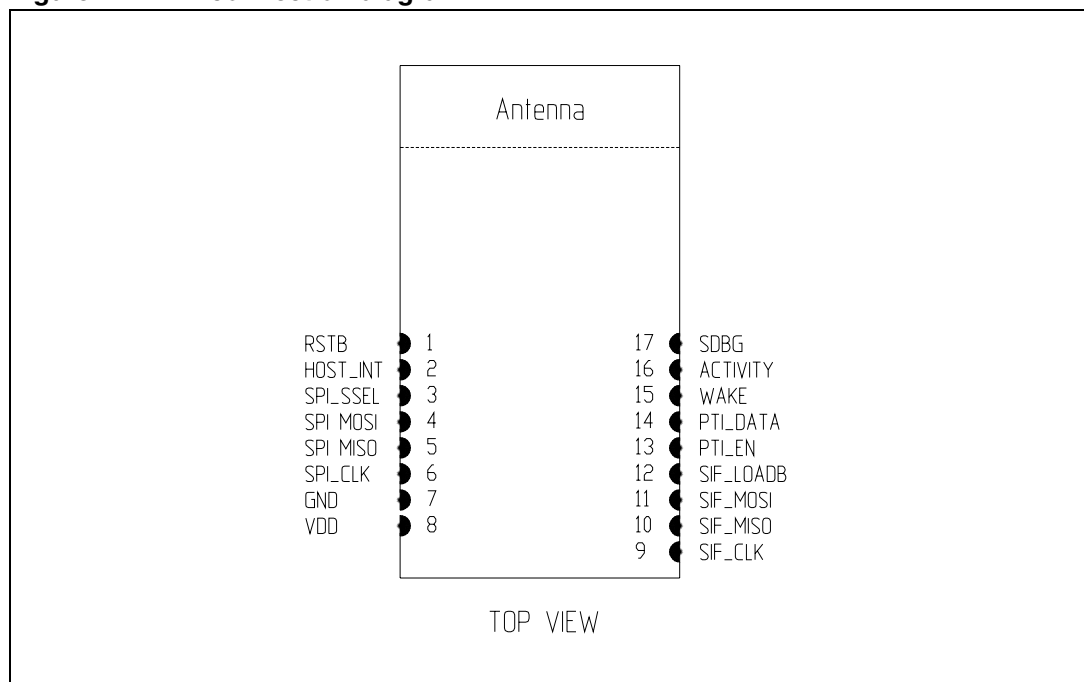

2.2 Pin description

Table 1. Pin description

Pin n	Pin name	Direction	Description
1	RSTB	I	Active low reset (an internal pull-up of 30 k Ω typ. is provided)
2	HOST_INT	O	Host interrupt signal (from ZB module to host)
3	SPI_SSEL	I	SPI slave select (from host to ZB module)
4	SPI MOSI	I	SPI data, master out / slave in (from host to ZB module)
5	SPI MISO	O	SPI data, master in / slave out (from ZB module to host)
6	SPI_CLK	I	SPI clock
7	GND	---	Ground
8	VDD	---	Input power supply
9	SIF_CLK	I	Non-intrusive debug interface Serial interface clock signal (internal pull-down)
10	SIF_MISO	O	Non-intrusive debug Interface Serial interface master IN/ slave out
11	SIF_MOSI	I	Non-intrusive debug Interface Serial interface master out/ slave in To guarantee a proper signal level when in deep sleep mode connect a 10 k Ω resistor to GND
12	SIF_LOADB	I/O	Non-intrusive debug Interface Serial interface load strobe (open collector with internal pull-up) To improve noise immunity connect a 10 k Ω resistor to V _{DD}
13	PTI_EN	O	Frame signal of packet trace interface (PTI)
14	PTI_DATA	O	Data signal of packet trace interface (PTI)
15	WAKE	I	Wake interrupt signal from host to ZB module
16	ACTIVITY	O	Activity signal for application debug /monitor
17	SDBG	O	

3 Maximum ratings

3.1 Absolute maximum ratings

Table 2. Absolute maximum ratings

Symbol	Parameter	Values		Unit
		Min.	Max.	
V_{DD}	Module supply voltage	-0.3	3.6	V
V_{IN}	Input voltage on any digital pin	-0.3	V _{DD} +0.3	V
T_{stg}	Storage temperature	-40	+85	°C
T_{sold}	Soldering temperature < 10 s		240	

3.2 Operating ranges

Table 3. Operating ranges

Symbol	Parameter	Conditions	Values			Unit
			Min.	Typ.	Max.	
V_{DD}	Module supply voltage	- 40 °C < T < 85 °C	2.1	3.3	3.6	V
T_{stg}	Operating ambient temperature		-40		+85	°C

4 Electrical characteristics

4.1 DC electrical characteristics

Table 4. DC electrical characteristics

Symbol	Parameter	Conditions	Values			Unit
			Min.	Typ.	Max.	
IRX	RX current (boost mode)	Vdd = 3.0 V, T = 25 °C	-	38		mA
IRX	RX current (normal mode)	Vdd = 3.0 V, T = 25 °C	-	36		mA
ITX	TX current (boost mode)	Vdd = 3.0 V, T = 25 °C	-	42		mA
ITX	TX current (normal mode)	Vdd = 3.0 V, T = 25 °C	-	36		mA
IDS	Deep sleep current	2.1 < Vdd < 3.6 V T = 25°C	-		1	μA

4.2 DC I/O specification

Table 5. DC input / output specification

Symbol	Parameter	Conditions	Values			Unit
			Min.	Typ.	Max.	
VIL	Low level input voltage	2.1 < Vdd < 3.6 V	0		0.2 x Vdd	V
VIH	High level input voltage	2.1 < Vdd < 3.6 V	0.8 x Vdd		Vdd	V
Iil	Input current for logic 0	2.1 < Vdd < 3.6 V			-0.5	mA
Iih	Input current for logic 1	2.1 < Vdd < 3.6 V			0.5	mA
Ripu	Input pull-up resistor			30		kΩ
Ripd	Input pull-down resistor			30		kΩ
VOL	Low level output voltage		0		0.18 x Vdd	V
VOH	High level output voltage		0.82 x Vdd		Vdd	V
IOHS	Output source current				4	mA
IOLS	Output sink current				4	mA
IOHH	Output source current (pin 15,16,17)				8	mA
IOLH	Output sink current (pin 15,16,17)				8	mA
IOTot	Total output current for I/O				40	mA

4.3 RF electrical characteristics

Table 6. RF electrical characteristics

Symbol	Parameter	Conditions	Values			Unit
			Min.	Typ.	Max.	
	Frequency range	2.1 < Vdd < 3.6 V	2405		2480	MHz
TX	Output power	Vdd = 3.0 V, F = 2450 MHz		3		dBm
RX	Sensitivity	Vdd = 3.0 V, 1% PER		-95		dBm
CFE	Carrier frequency error	Vdd = 3.0 V -20 / + 70 °C	-40		40	ppm
	Error Vector magnitude	Normal / boost mode		15	25	%
	Adjacent channel rejection	+/- 5 MHz +/- 10 MHz		35 40		dBm

5 Package mechanical dimensions

In order to meet environmental requirements, ST offers these devices in different grades of ECOPACK® packages, depending on their level of environmental compliance. ECOPACK® specifications, grade definitions and product status are available at: www.st.com. ECOPACK® is an ST trademark.

Figure 3. Mechanical dimensions

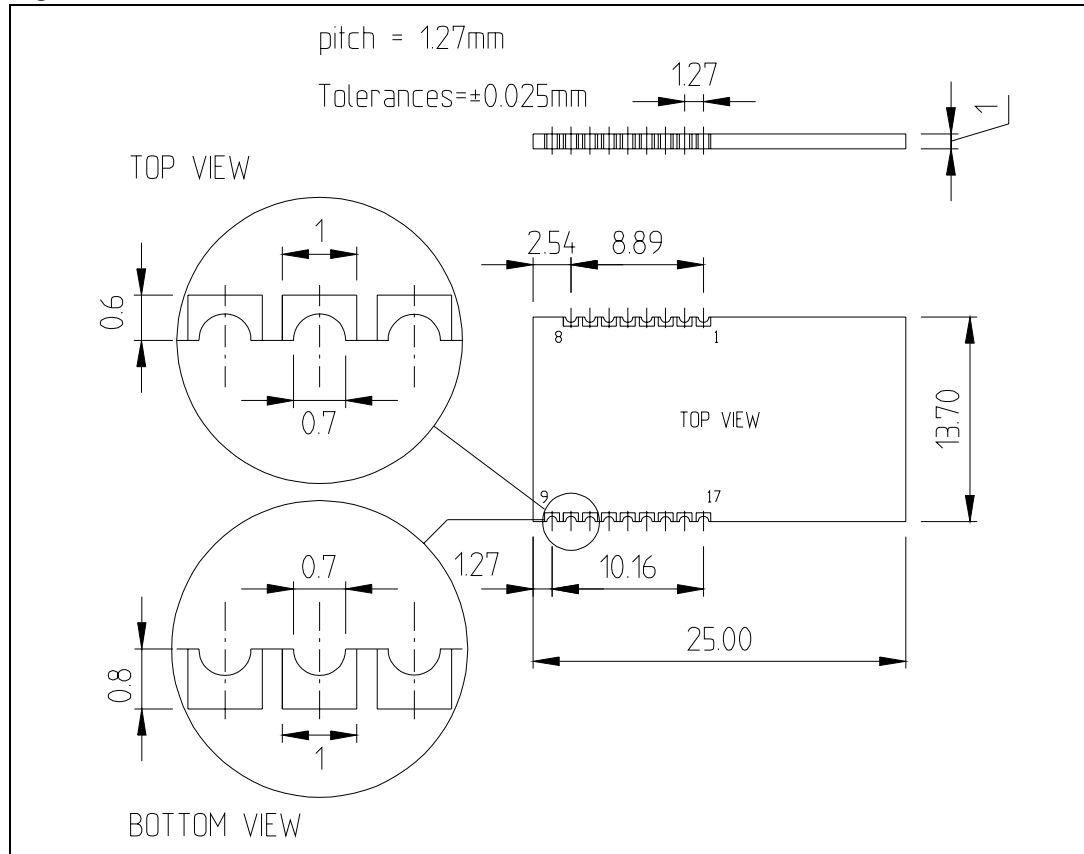
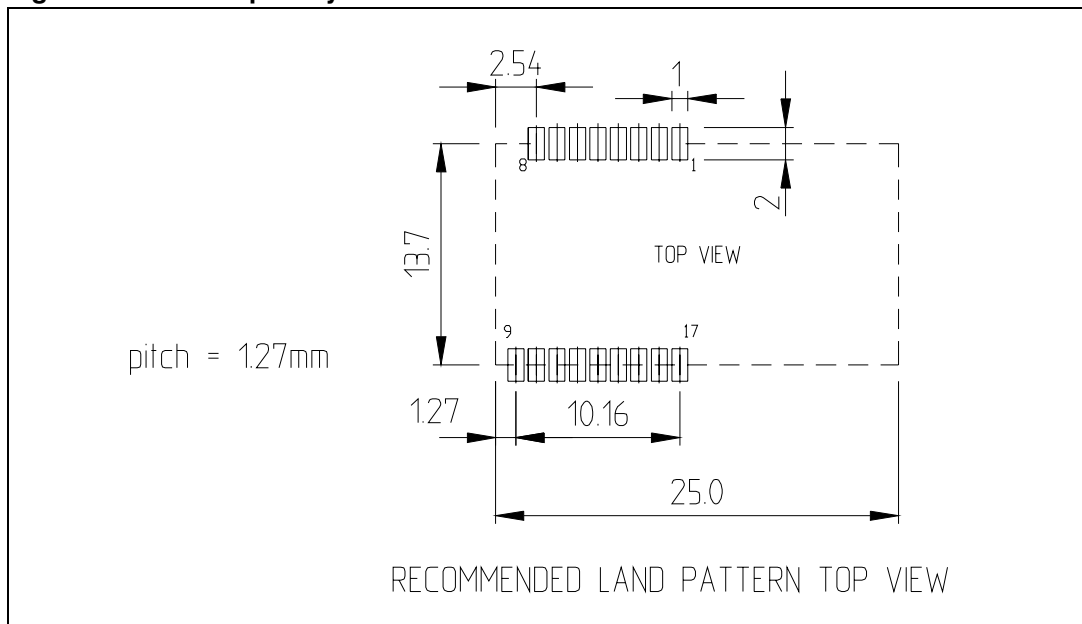

Figure 4. Solder pad layout



6 Soldering

Soldering phase has to be executed with care: in order to avoid undesired melting phenomenon, particular attention has to be taken on the set up of the peak temperature.

Here following some suggestions for the temperature profile based on IPC/JEDEC J-STD-020C, July 2004 recommendations.

Table 7. Soldering

Profile feature	PB free assembly
Average ramp up rate (TSMAX to TP)	3 °C / sec max
Preheat	
Temperature min (TS MIN)	150 °C
Temperature max (TS MAX)	200 °C
Time (TS MIN to TS MAX) (ts)	60 – 100 sec
Time maintained above:	
Temperature TL	217 °C
Time tL	40 – 70 sec
Peak temperature (Tp)	240+0 °C
Time within 5 °C of actual peak temperature (tP)	10 – 20 sec
Ramp down rate	6 °C / sec
Time from 25 °C to peak temperature	8 minutes max

Figure 5. Soldering

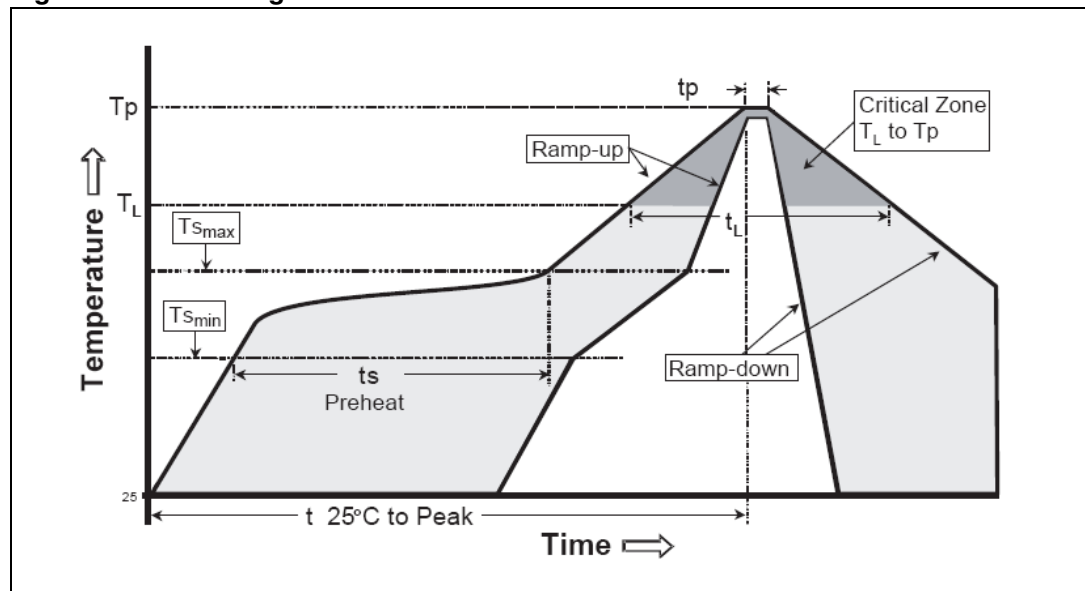

Appendix A FCC statement (b)

This device complies with part 15 of the FCC rules. Operation is subject to the following two conditions: (1) this device may not cause harmful interference, and (2) this device must accept any interference received, including interference that may cause undesired operation.

Note: This equipment has been tested and found to comply with the limits for a class B digital device, pursuant to part 15 of the FCC rules. These limits are designed to provide reasonable protection against harmful interference in a residential installation. This equipment generates, uses and can radiate radio frequency energy and, if not installed and used in accordance with the instructions, may cause harmful interference to radio communications. However, there is no guarantee that interference will not occur in a particular installation. If this equipment does cause harmful interference to radio or television reception, which can be determined by turning the equipment off and on, the user is encouraged to try to correct the interference by one or more of the following measures:

- Reorient or relocate the receiving antenna
- Increase the separation between the equipment and receiver
- Connect the equipment into an outlet on a circuit different from that to which the receiver is connected

Consult the dealer or an experienced radio/TV technician for help.

Antenna

Our module type SPZB260 is for OEM integrations only. The end-user product will be professionally installed in such a manner that only the authorized antennas are used.

Caution

Any changes or modifications not expressed approved by the part responsible for compliance could cause the module to cease to comply with FCC rules part 15, and thus void the user's authority to operate the equipment.

b. SPZB260-PRO is based on the same unmodified HW of SPZB260 module. The same FCC certification statement applies.

A.1 Label instruction

Instruction manual for FCC ID labeling

Module type: ZigBee® module *SPZB260*

FCC-ID: S9NZB260A

This intends to inform you how to specify the FCC ID of our ZigBee® module SPZB260 on your final product.

Based on the public notice from FCC, the product into which our transmitter module is installed must display a label referring to the enclosed module.

The label should use wording such as “contains transmitter module FCC ID: S9NZB260A or “contains FCC ID: S9NZB260A, any similar wording that expressed the same meaning may be use.

It shows an example below

Contains FCC ID: S9NZB260A

A.2 Special requirement for modular application

The following requirements are fulfilled:

1. The modular transmitter must have its own RF shielding:
The RF module used on the board fulfils the emission requirements of the FCC rules without additional shielding.
2. The modular transmitter must have buffered modulation/data inputs:
The module has a memory management unit inside of the IC. The processor interfacing with the external application by means general purpose I/O (GPIO), Uart, SPI. The processor interfaces also the RF part of the module exchanging data and command with it. Inside the processor a flash memory is available to download the customer application and the ZigBee® profiles.
3. The modular transmitter must have its own power supply regulation:
The IC contains an own voltage regulation. In case of changes in the supply voltage VCC (for example caused by temperature changes or other effects), the internal voltage will be stabilized.
4. The modular transmitter must comply with the antenna requirements of section 15.203 and 15.204:
The RF module is for OEM (original equipment manufacturer) integration only. The end-user product will be professionally installed in such a manner that only the authorized antenna is used.
5. The modular transmitter must be tested in a stand-alone configuration:
The RF module was tested in a stand-alone configuration.
6. The modular transmitter must be labelled with its own FCC ID number:
The RF module will be labelled with its own FCC ID number. When the module is installed inside the end-product, the label is not visible. The OEM manufacturer is instructed how to apply the exterior label.

7. The modular transmitter must comply with any specific rule or operating requirements applicable to the transmitter and the manufacturer must provide adequate instructions along with the module to explain any such requirements:
The EUT is compliant with all applicable FCC rules. Detail instructions are given in the product users guide.
8. The modular transmitter must comply with any applicable RF exposure requirements.
 - Maximum measured power output: 3,08 mW
 - Maximum antenna gain: 0,6 dBi = numeric gain 1,148 (see also FCC test report)

Maximum permissible exposure defined in 47 CFR 1.1310: 1 mW/cm².

The RF module operates at low power level so it does not exceed the commission's RF exposure guidelines limits; furthermore, spread spectrum transmitters operate according to the section 15.247 are categorically excluded from routine environmental evaluation.

7 Revision history

Table 8. Document revision history

Date	Revision	Changes
22-Apr-2009	1	First release

Please Read Carefully:

Information in this document is provided solely in connection with ST products. STMicroelectronics NV and its subsidiaries ("ST") reserve the right to make changes, corrections, modifications or improvements, to this document, and the products and services described herein at any time, without notice.

All ST products are sold pursuant to ST's terms and conditions of sale.

Purchasers are solely responsible for the choice, selection and use of the ST products and services described herein, and ST assumes no liability whatsoever relating to the choice, selection or use of the ST products and services described herein.

No license, express or implied, by estoppel or otherwise, to any intellectual property rights is granted under this document. If any part of this document refers to any third party products or services it shall not be deemed a license grant by ST for the use of such third party products or services, or any intellectual property contained therein or considered as a warranty covering the use in any manner whatsoever of such third party products or services or any intellectual property contained therein.

UNLESS OTHERWISE SET FORTH IN ST'S TERMS AND CONDITIONS OF SALE ST DISCLAIMS ANY EXPRESS OR IMPLIED WARRANTY WITH RESPECT TO THE USE AND/OR SALE OF ST PRODUCTS INCLUDING WITHOUT LIMITATION IMPLIED WARRANTIES OF MERCHANTABILITY, FITNESS FOR A PARTICULAR PURPOSE (AND THEIR EQUIVALENTS UNDER THE LAWS OF ANY JURISDICTION), OR INFRINGEMENT OF ANY PATENT, COPYRIGHT OR OTHER INTELLECTUAL PROPERTY RIGHT.

UNLESS EXPRESSLY APPROVED IN WRITING BY AN AUTHORIZED ST REPRESENTATIVE, ST PRODUCTS ARE NOT RECOMMENDED, AUTHORIZED OR WARRANTED FOR USE IN MILITARY, AIR CRAFT, SPACE, LIFE SAVING, OR LIFE SUSTAINING APPLICATIONS, NOR IN PRODUCTS OR SYSTEMS WHERE FAILURE OR MALFUNCTION MAY RESULT IN PERSONAL INJURY, DEATH, OR SEVERE PROPERTY OR ENVIRONMENTAL DAMAGE. ST PRODUCTS WHICH ARE NOT SPECIFIED AS "AUTOMOTIVE GRADE" MAY ONLY BE USED IN AUTOMOTIVE APPLICATIONS AT USER'S OWN RISK.

Resale of ST products with provisions different from the statements and/or technical features set forth in this document shall immediately void any warranty granted by ST for the ST product or service described herein and shall not create or extend in any manner whatsoever, any liability of ST.

ST and the ST logo are trademarks or registered trademarks of ST in various countries.

Information in this document supersedes and replaces all information previously supplied.

The ST logo is a registered trademark of STMicroelectronics. All other names are the property of their respective owners.

© 2009 STMicroelectronics - All rights reserved

STMicroelectronics group of companies

Australia - Belgium - Brazil - Canada - China - Czech Republic - Finland - France - Germany - Hong Kong - India - Israel - Italy - Japan - Malaysia - Malta - Morocco - Philippines - Singapore - Spain - Sweden - Switzerland - United Kingdom - United States of America

www.st.com