

### Features

Type	$R_{DS(on)}$	$I_{OUT}$	$V_{CC}$
VN750SMP-E	55 m $\Omega$	6 A	36 V

- ECOPACK<sup>®</sup> : lead free and RoHS compliant
- Automotive Grade: compliance with AEC guidelines
- CMOS compatible input
- On-state open-load detection
- Off-state open-load detection
- Shorted load protection
- Undervoltage and overvoltage shutdown
- Protection against loss of ground
- Very low standby current
- Reverse battery protection (see [Application schematic on page 16](#))
- In compliance with the 2002/95/EC european directive

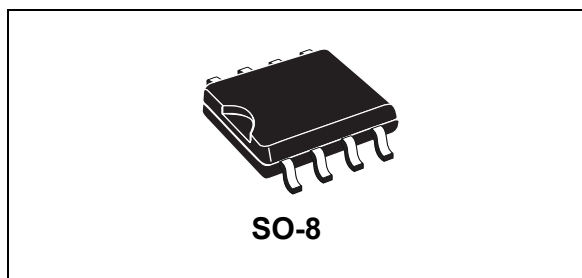

### Description

The VN750SMP-E is a monolithic device designed in STMicroelectronics VIPower™ M0-3 Technology, intended for driving any kind of load with one side connected to ground.

Active  $V_{CC}$  pin voltage clamp protects the device against low energy spikes (see ISO7637 transient compatibility table). Active current limitation combined with thermal shutdown and automatic restart help protect the device against overload.

The device detects open-load condition in on and off-state. The open-load threshold is aimed at detecting the 5W/12V standard bulb as an open-load fault in the on-state. Output shorted to  $V_{CC}$  is detected in the off-state. Device automatically turns off in case of ground pin disconnection.

**Table 1. Device summary**

Package	Order codes	
	Tube	Tape and reel
SO-8	VN750SMP-E	VN750SMPTR-E

# Contents

<b>1</b>	<b>Block diagram and pin description</b>	<b>5</b>
<b>2</b>	<b>Electrical specifications</b>	<b>6</b>
2.1	Absolute maximum ratings	6
2.2	Thermal data	7
2.3	Electrical characteristics	7
2.4	Electrical characteristics curves	13
2.5	GND protection network against reverse battery	16
2.5.1	Solution 1: resistor in the ground line (RGND only)	16
2.5.2	Solution 2: diode (DGND) in the ground line	17
2.6	Load dump protection	17
2.7	Microcontroller I/Os protection	17
2.8	Open-load detection in off-state	17
2.9	SO-8 maximum demagnetization energy ( $V_{CC} = 13.5\text{ V}$ )	19
<b>3</b>	<b>Package and PCB thermal data</b>	<b>20</b>
3.1	SO-8 thermal data	20
<b>4</b>	<b>Package and packing information</b>	<b>23</b>
4.1	ECOPACK <sup>®</sup> packages	23
4.2	SO-8 mechanical data	23
4.3	Packing information	24
<b>5</b>	<b>Revision history</b>	<b>26</b>

## List of tables

Table 1.	Device summary . . . . .	1
Table 2.	Suggested connections for unused and not connected pins . . . . .	5
Table 3.	Absolute maximum ratings . . . . .	6
Table 4.	Thermal data. . . . .	7
Table 5.	Power . . . . .	7
Table 6.	Switching ( $V_{CC}=13\text{ V}$ ). . . . .	8
Table 7.	Input pin . . . . .	8
Table 8.	$V_{CC}$ output diode. . . . .	8
Table 9.	Status pin . . . . .	8
Table 10.	Protections . . . . .	9
Table 11.	Open-load detection . . . . .	9
Table 12.	Truth table. . . . .	10
Table 13.	Electrical transient requirements on $V_{CC}$ pin (part 1/3). . . . .	11
Table 14.	Electrical transient requirements on $V_{CC}$ pin (part 2/3). . . . .	11
Table 15.	Electrical transient requirements on $V_{CC}$ pin (part 3/3). . . . .	11
Table 16.	SO-8 thermal parameter. . . . .	21
Table 17.	SO-8 mechanical data . . . . .	23
Table 18.	Document revision history . . . . .	26

## List of figures

Figure 1.	Block diagram . . . . .	5
Figure 2.	Configuration diagram (top view) . . . . .	5
Figure 3.	Current and voltage conventions . . . . .	6
Figure 4.	Status timings . . . . .	10
Figure 5.	Switching time waveforms . . . . .	10
Figure 6.	Waveforms . . . . .	12
Figure 7.	Off-state output current . . . . .	13
Figure 8.	High level input current . . . . .	13
Figure 9.	Input clamp voltage . . . . .	13
Figure 10.	Status leakage current . . . . .	13
Figure 11.	Status low output voltage . . . . .	13
Figure 12.	Status clamp voltage . . . . .	13
Figure 13.	On-state resistance vs $T_{case}$ . . . . .	14
Figure 14.	On-state resistance vs $V_{CC}$ . . . . .	14
Figure 15.	Open-load on-state detection threshold . . . . .	14
Figure 16.	Open-load off-state voltage detection threshold . . . . .	14
Figure 17.	Input high level . . . . .	14
Figure 18.	Input low level . . . . .	14
Figure 19.	Turn-on voltage slope . . . . .	15
Figure 20.	Turn-off voltage slope . . . . .	15
Figure 21.	Overshoot shutdown . . . . .	15
Figure 22.	$I_{lim}$ vs $T_{case}$ . . . . .	15
Figure 23.	Input hysteresis voltage . . . . .	15
Figure 24.	Application schematic . . . . .	16
Figure 25.	Open-load detection in off-state . . . . .	18
Figure 26.	SO-8 maximum turn-off current versus inductance . . . . .	19
Figure 27.	SO-8 PC board . . . . .	20
Figure 28.	$R_{thj-amb}$ vs PCB copper area in open box free air condition . . . . .	20
Figure 29.	SO-8 thermal impedance junction ambient single pulse . . . . .	21
Figure 30.	SO-8 thermal fitting model of a single channel . . . . .	21
Figure 31.	SO-8 package dimensions . . . . .	23
Figure 32.	SO-8 tube shipment (no suffix) . . . . .	24
Figure 33.	SO-8 tape and reel shipment (suffix "TR") . . . . .	25

# 1 Block diagram and pin description

Figure 1. Block diagram

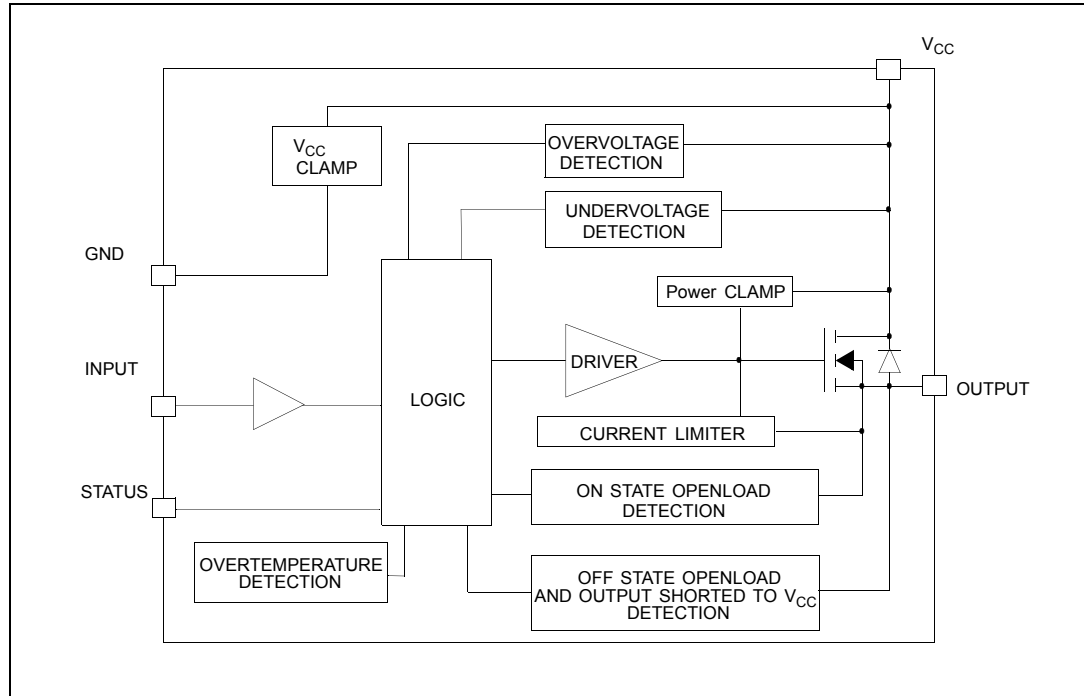

Figure 2. Configuration diagram (top view)

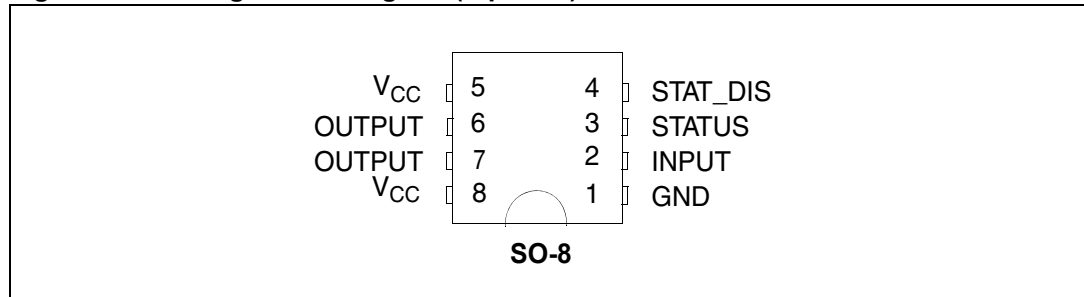
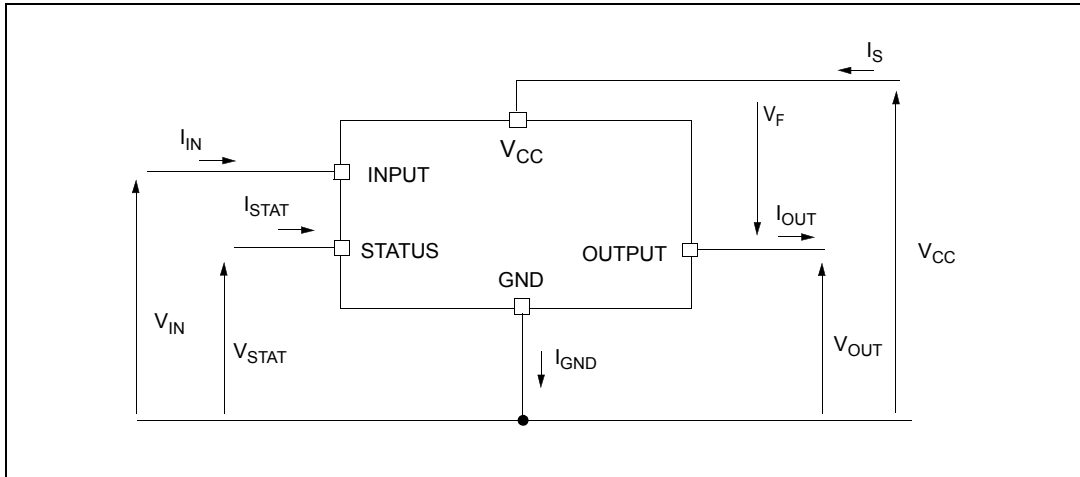

Table 2. Suggested connections for unused and not connected pins

Connection/pin	Status	N.C.	Output	Input
Floating	X	X	X	X
To ground		X		Through 10 K $\Omega$ resistor

## 2 Electrical specifications

Figure 3. Current and voltage conventions



### 2.1 Absolute maximum ratings

Stress values that exceed those listed in the “Absolute maximum ratings” table can cause permanent damage to the device. These are stress ratings only, and operation of the device at these, or any other conditions greater than those, indicated in the operating sections of this specification is not implied. Exposure to absolute maximum rating conditions for extended periods may affect device reliability. Refer also to the STMicroelectronics sure program and other relevant quality documents.

Table 3. Absolute maximum ratings

Symbol	Parameter	Value	Unit
$V_{CC}$	DC supply voltage	41	V
$-V_{CC}$	Reverse DC supply voltage	- 0.3	V
$-I_{gnd}$	DC reverse ground pin current	- 200	mA
$I_{OUT}$	DC output current	Internally limited	A
$-I_{OUT}$	Reverse DC output current	- 6	A
$I_{IN}$	DC input current	+/- 10	mA
$I_{STAT}$	DC status current	+/- 10	mA
$V_{ESD}$	Electrostatic discharge (human body model: R=1.5 K $\Omega$ ; C=100pF)		
	- Input	4000	V
	- Status	4000	V
	- Output	5000	V
	$-V_{CC}$	5000	V

**Table 3. Absolute maximum ratings (continued)**

Symbol	Parameter	Value	Unit
$E_{MAX}$	Maximum switching energy ( $L=1.3\text{mH}$ ; $R_L=0\Omega$ ; $V_{bat}=13.5\text{V}$ ; $T_{jstart}=150^\circ\text{C}$ ; $I_L=10\text{A}$ )	90	mJ
$P_{tot}$	Power dissipation $T_C=25^\circ\text{C}$	4.2	W
$T_j$	Junction operating temperature	Internally limited	$^\circ\text{C}$
$T_{stg}$	Storage temperature	- 55 to 150	$^\circ\text{C}$

## 2.2 Thermal data

**Table 4. Thermal data**

Symbol	Parameter	Max. value		Unit
$R_{thj-case}$	Thermal resistance junction-case	1.7		$^\circ\text{C/W}$
$R_{thj-amb}$	Thermal resistance junction-ambient	93 <sup>(1)</sup>	82 <sup>(2)</sup>	$^\circ\text{C/W}$

- When mounted on a standard single-sided FR-4 board with  $0.5\text{cm}^2$  of Cu (at least  $35\mu\text{m}$  thick) connected to all  $V_{CC}$  pins. Horizontal mounting and no artificial air flow.
- When mounted on a standard single-sided FR-4 board with  $2\text{cm}^2$  of Cu (at least  $35\mu\text{m}$  thick) connected to all  $V_{CC}$  pins. Horizontal mounting and no artificial air flow.

## 2.3 Electrical characteristics

Values specified in this section are for  $8\text{V} < V_{CC} < 36\text{V}$ ;  $-40^\circ\text{C} < T_j < 150^\circ\text{C}$ , unless otherwise specified.

**Table 5. Power**

Symbol	Parameter	Test conditions	Min.	Typ.	Max.	Unit
$V_{CC}$	Operating supply voltage		5.5	13	36	V
$V_{USD}$	Undervoltage shutdown		3	4	5.5	V
$V_{USDhyst}$	Undervoltage shutdown hysteresis			0.5		V
$V_{OV}$	Overvoltage shutdown		36			V
$R_{ON}$	On-state resistance	$I_{OUT}=2\text{A}$ ; $T_j=25^\circ\text{C}$ ; $V_{CC}>8\text{V}$ $I_{OUT}=2\text{A}$ ; $V_{CC}>8\text{V}$			55 110	$\text{m}\Omega$ $\text{m}\Omega$
$I_S$	Supply current	Off-state; $V_{CC}=13\text{V}$ ; $V_{IN}=V_{OUT}=0\text{V}$ Off-state; $V_{CC}=13\text{V}$ ; $V_{IN}=V_{OUT}=0\text{V}$ ; $T_j=25^\circ\text{C}$ On-state; $V_{CC}=13\text{V}$ ; $V_{IN}=5\text{V}$ ; $I_{OUT}=0\text{A}$		10 10 2	25 20 3.5	$\mu\text{A}$ $\mu\text{A}$ mA
$I_{L(off1)}$	Off-state output current	$V_{IN}=V_{OUT}=0\text{V}$	0		50	$\mu\text{A}$
$I_{L(off2)}$	Off-state output current	$V_{IN}=0\text{V}$ ; $V_{OUT}=3.5\text{V}$	-75		0	$\mu\text{A}$

**Table 5. Power (continued)**

Symbol	Parameter	Test conditions	Min.	Typ.	Max.	Unit
$I_{L(off3)}$	Off-state output current	$V_{IN}=V_{OUT}=0$ V; $V_{CC}=13$ V; $T_j=125$ °C			5	$\mu$ A
$I_{L(off4)}$	Off-state output current	$V_{IN}=V_{OUT}=0$ V; $V_{CC}=13$ V; $T_j=25$ °C			3	$\mu$ A

**Table 6. Switching ( $V_{CC}=13$  V)**

Symbol	Parameter	Test conditions	Min.	Typ.	Max.	Unit
$t_{d(on)}$	Turn-on delay time	$R_L=6.5$ $\Omega$ from $V_{IN}$ rising edge to $V_{OUT}=1.3$ V	-	40	-	$\mu$ s
$t_{d(off)}$	Turn-off delay time	$R_L=6.5$ $\Omega$ from $V_{IN}$ falling edge to $V_{OUT}=11.7$ V	-	30	-	$\mu$ s
$dV_{OUT}/dt_{(on)}$	Turn-on voltage slope	$R_L=6.5$ $\Omega$ from $V_{OUT}=1.3$ V to $V_{OUT}=10.4$ V	-	See relative diagram	-	V/ $\mu$ s
$dV_{OUT}/dt_{(off)}$	Turn-off voltage slope	$R_L=6.5$ $\Omega$ from $V_{OUT}=11.7$ V to $V_{OUT}=1.3$ V	-	See relative diagram	-	V/ $\mu$ s

**Table 7. Input pin**

Symbol	Parameter	Test conditions	Min.	Typ.	Max.	Unit
$V_{IL}$	Input low level				1.25	V
$I_{IL}$	Low level input current	$V_{IN}=1.25$ V	1			$\mu$ A
$V_{IH}$	Input high level		3.25			V
$I_{IH}$	High level input current	$V_{IN}=3.25$ V			10	$\mu$ A
$V_{hyst}$	Input hysteresis voltage		0.5			V
$V_{ICL}$	Input clamp voltage	$I_{IN}=1$ mA $I_{IN}=-1$ mA	6	6.8 -0.7	8	V V

**Table 8.  $V_{CC}$  output diode**

Symbol	Parameter	Test conditions	Min.	Typ.	Max.	Unit
$V_F$	Forward on voltage	$-I_{OUT}=1.4$ A; $T_j=150$ °C			0.6	V

**Table 9. Status pin**

Symbol	Parameter	Test conditions	Min.	Typ.	Max.	Unit
$V_{STAT}$	Status low output voltage	$I_{STAT}=1.6$ mA			0.5	V
$I_{LSTAT}$	Status leakage current	Normal operation; $V_{STAT}=5$ V			10	$\mu$ A

Table 9. Status pin (continued)

Symbol	Parameter	Test conditions	Min.	Typ.	Max.	Unit
$C_{STAT}$	Status pin input capacitance	Normal operation; $V_{STAT}=5\text{ V}$			100	pF
$V_{SCL}$	Status clamp voltage	$I_{STAT}=1\text{mA}$ $I_{STAT}=-1\text{mA}$	6	6.8 -0.7	8	V V

Table 10. Protections<sup>(1)</sup>

Symbol	Parameter	Test conditions	Min.	Typ.	Max.	Unit
$T_{TSD}$	Shutdown temperature		150	175	200	°C
$T_R$	Reset temperature		135			°C
$T_{hyst}$	Thermal hysteresis		7	15		°C
$t_{SDL}$	Status delay in overload condition	$T_j > T_{jsh}$			20	ms
$I_{lim}$	Current limitation	$5.5\text{ V} < V_{CC} < 36\text{ V}$	6	10	12 12	A A
$V_{demag}$	Turn-off output clamp voltage	$I_{OUT}=2\text{ A}$ ; $V_{IN}=0\text{ V}$ ; $L=6\text{ mH}$	$V_{CC}-41$	$V_{CC}-48$	$V_{CC}-55$	V

1. To ensure long term reliability under heavy overload or short circuit conditions, protection and related diagnostic signals must be used together with a proper software strategy. If the device operates under abnormal conditions this software must limit the duration and number of activation cycles.

Table 11. Open-load detection

Symbol	Parameter	Test conditions	Min.	Typ.	Max.	Unit
$I_{OL}$	Open-load on-state detection threshold	$V_{IN}=5\text{ V}$	0.6	0.9	1.2	A
$t_{DOL(on)}$	Open-load on-state detection delay	$I_{OUT}=0\text{ A}$			200	μs
$V_{OL}$	Open-load off-state voltage detection threshold	$V_{IN}=0\text{ V}$	1.5	2.5	3.5	V
$t_{DOL(off)}$	Open-load detection delay at turn-off				1000	μs

Figure 4. Status timings

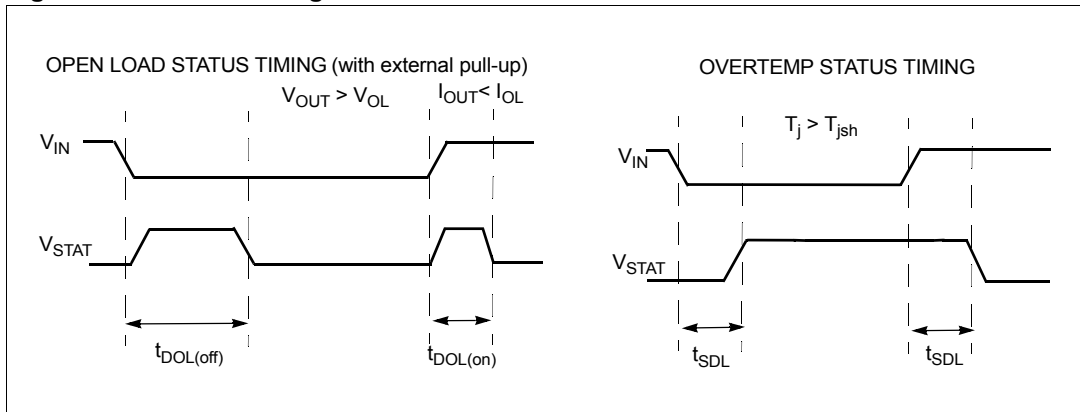

Figure 5. Switching time waveforms

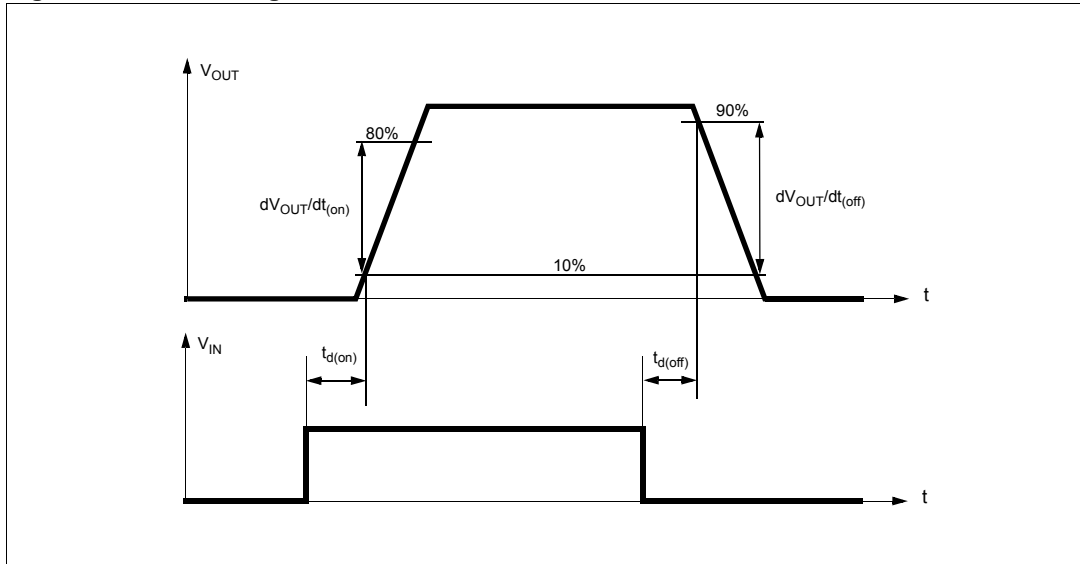

Table 12. Truth table

Conditions	Input	Output	Status
Normal operation	L	L	H
	H	H	H
Current limitation	L	L	H
	H	X	$(T_j < T_{TSD})$ H
	H	X	$(T_j > T_{TSD})$ L
Overtemperature	L	L	H
	H	L	L
Undervoltage	L	L	X
	H	L	X
Overvoltage	L	L	H
	H	L	H

**Table 12. Truth table**

Conditions	Input	Output	Status
Output voltage > $V_{OL}$	L	H	L
	H	H	H
Output current < $I_{OL}$	L	L	H
	H	H	L

**Table 13. Electrical transient requirements on  $V_{CC}$  pin (part 1/3)**

ISO T/R 7637/1 test pulse	Test levels				Delays and impedance
	I	II	III	IV	
1	-25 V	-50 V	-75 V	-100 V	2 ms 10 $\Omega$
2	+25 V	+50 V	+75 V	+100 V	0.2 ms 10 $\Omega$
3a	-25 V	-50 V	-100 V	-150 V	0.1 $\mu$ s 50 $\Omega$
3b	+25 V	+50 V	+75 V	+100 V	0.1 $\mu$ s 50 $\Omega$
4	-4 V	-5 V	-6 V	-7 V	100 ms, 0.01 $\Omega$
5	+26.5 V	+46.5 V	+66.5 V	+86.5 V	400 ms, 2 $\Omega$

**Table 14. Electrical transient requirements on  $V_{CC}$  pin (part 2/3)**

ISO T/R 7637/1 test pulse	Test levels results			
	I	II	III	IV
1	C	C	C	C
2	C	C	C	C
3a	C	C	C	C
3b	C	C	C	C
4	C	C	C	C
5	C	E	E	E

**Table 15. Electrical transient requirements on  $V_{CC}$  pin (part 3/3)**

Class	Contents
C	All functions of the device are performed as designed after exposure to disturbance.
E	One or more functions of the device is not performed as designed after exposure to disturbance and cannot be returned to proper operation without replacing the device.

Figure 6. Waveforms

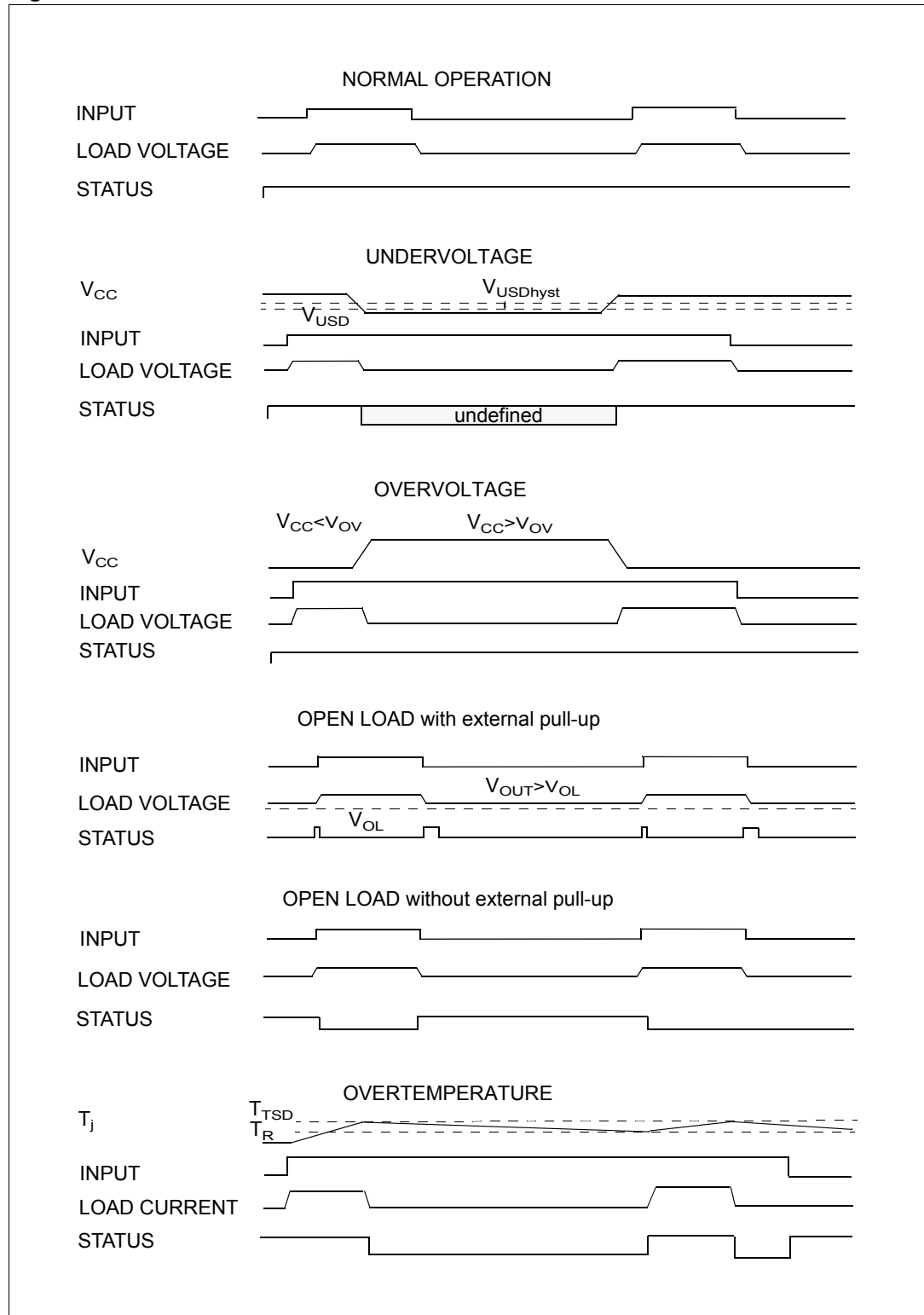

## 2.4 Electrical characteristics curves

**Figure 7. Off-state output current**

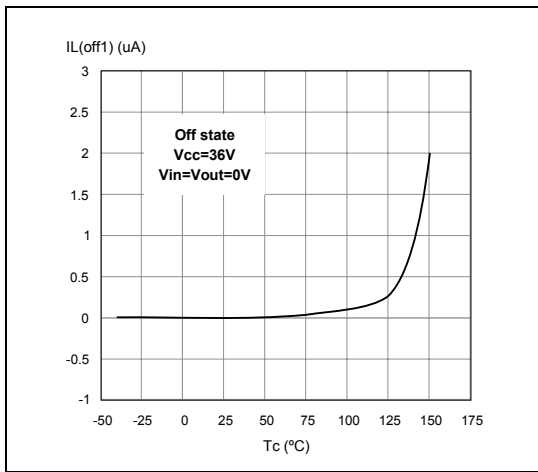

**Figure 8. High level input current**

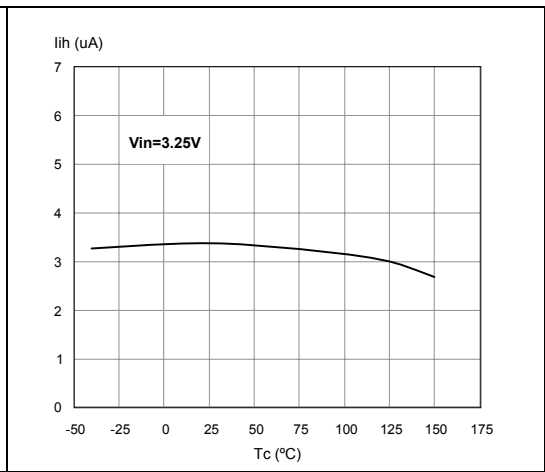

**Figure 9. Input clamp voltage**

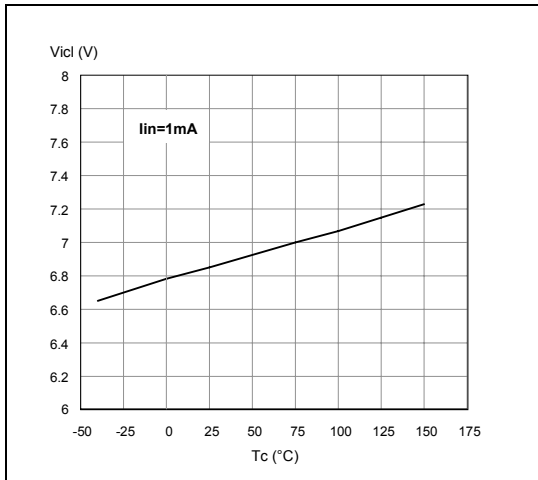

**Figure 10. Status leakage current**

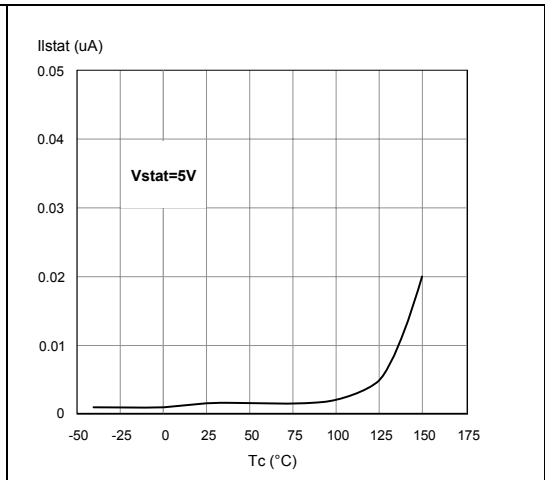

**Figure 11. Status low output voltage**

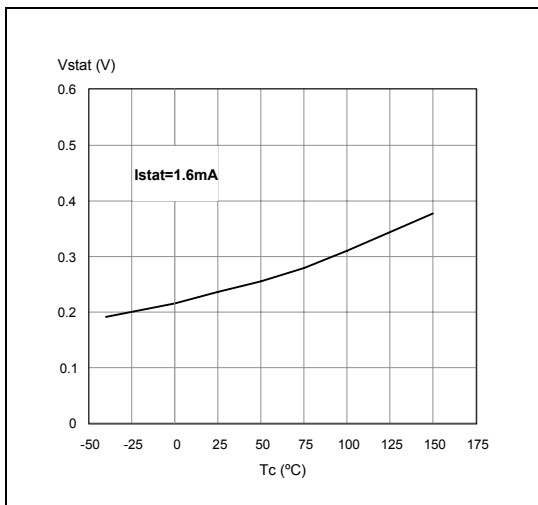

**Figure 12. Status clamp voltage**

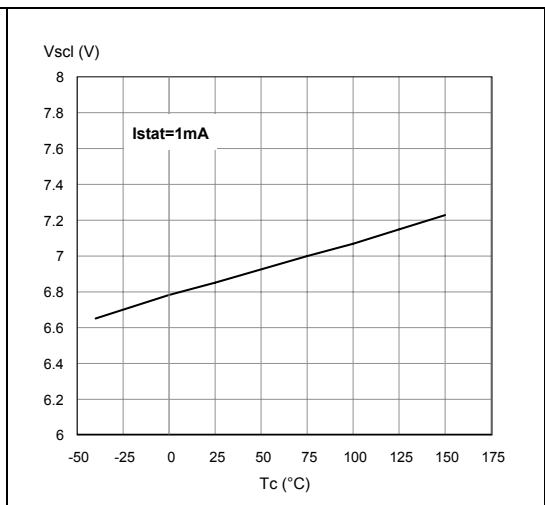

Figure 13. On-state resistance vs  $T_{case}$

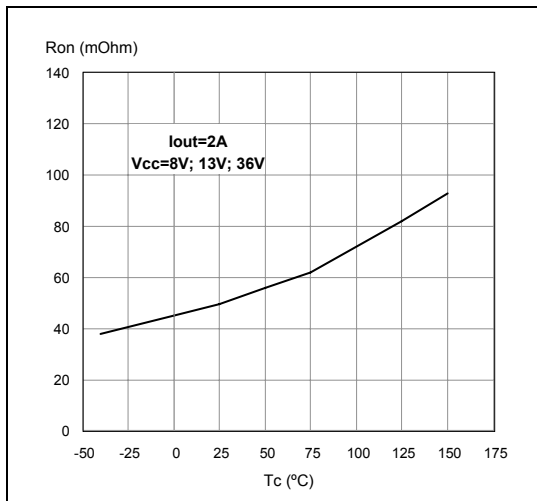

Figure 14. On-state resistance vs  $V_{CC}$

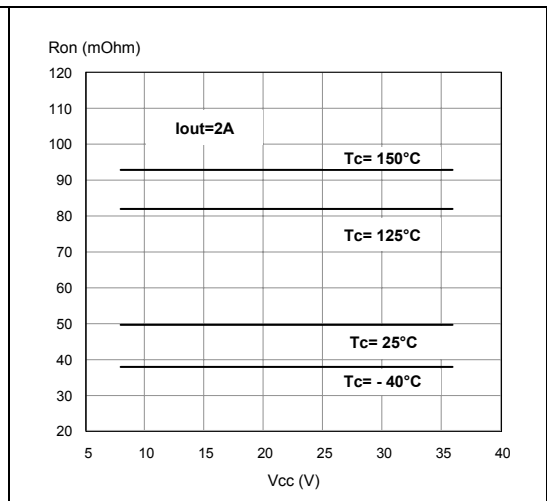

Figure 15. Open-load on-state detection threshold

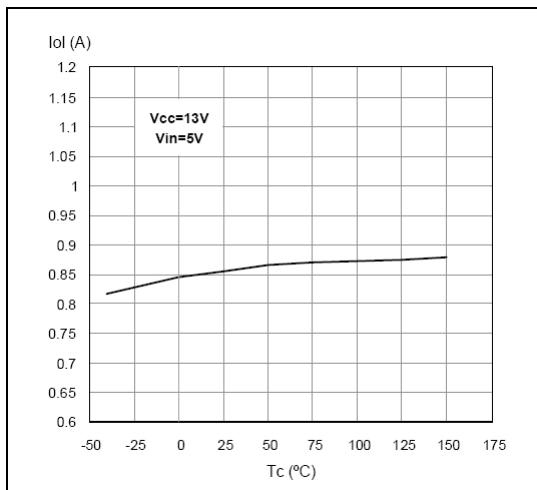

Figure 16. Open-load off-state voltage detection threshold

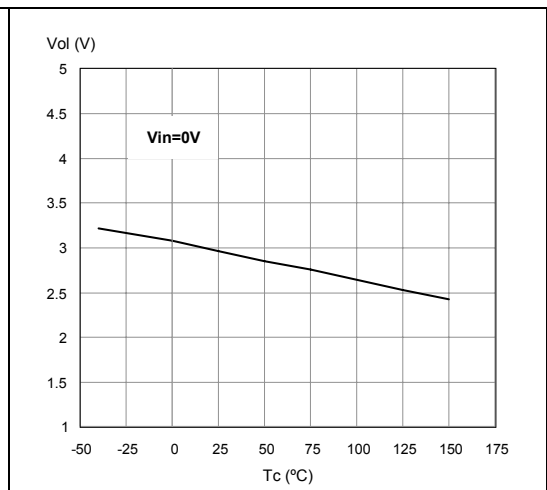

Figure 17. Input high level

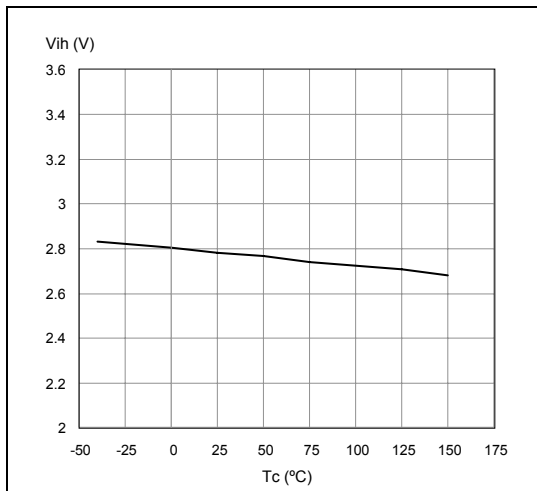

Figure 18. Input low level

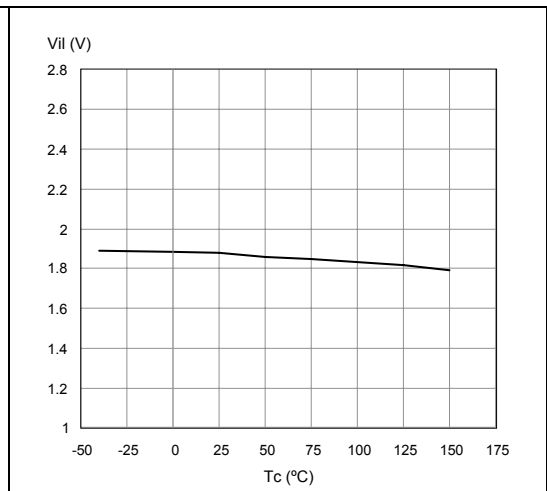

Figure 19. Turn-on voltage slope

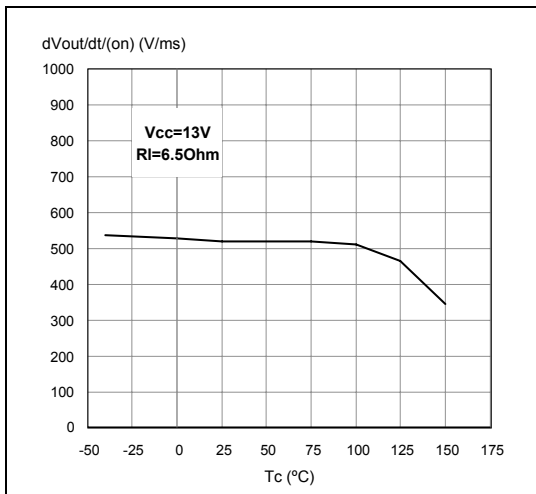

Figure 20. Turn-off voltage slope

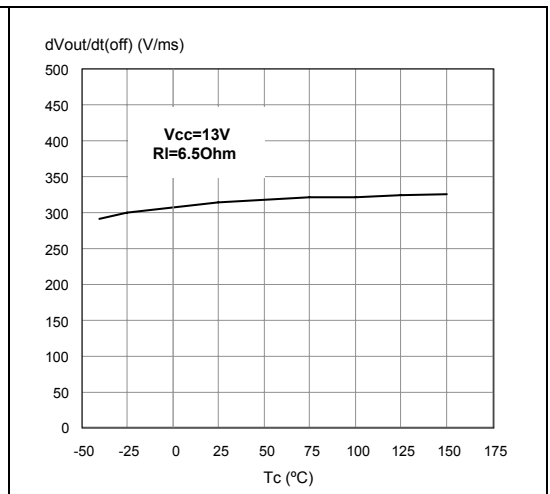

Figure 21. Overvoltage shutdown

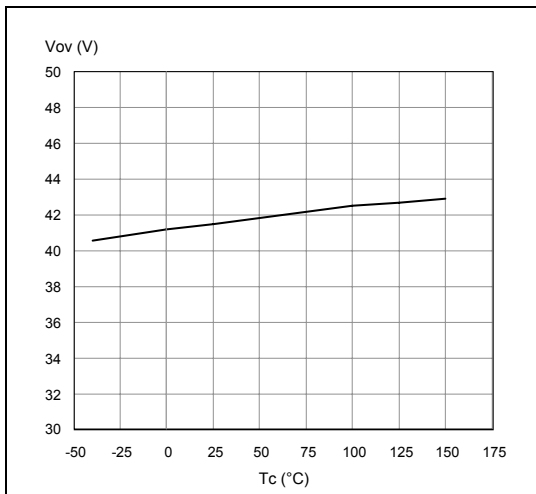

Figure 22. Ilim vs Tcase

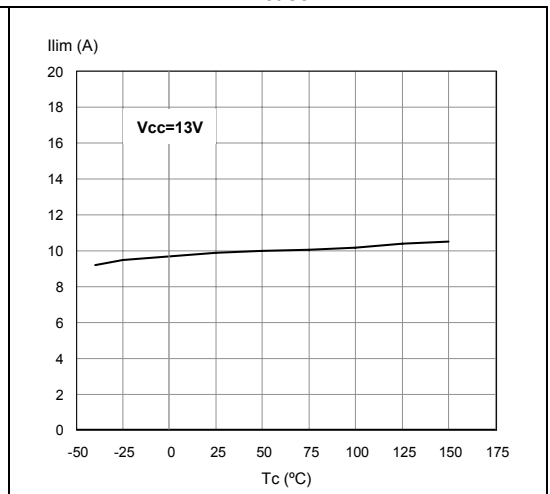

Figure 23. Input hysteresis voltage

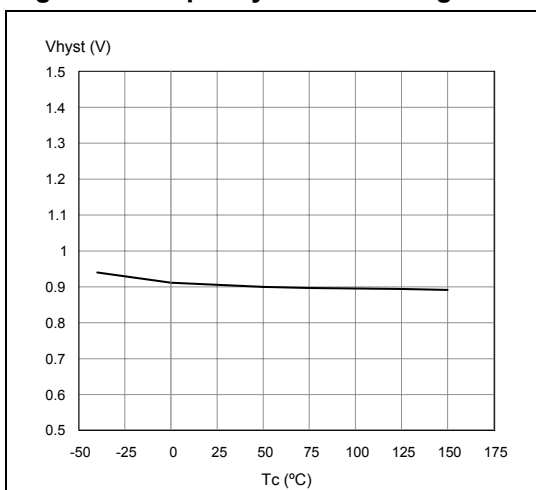
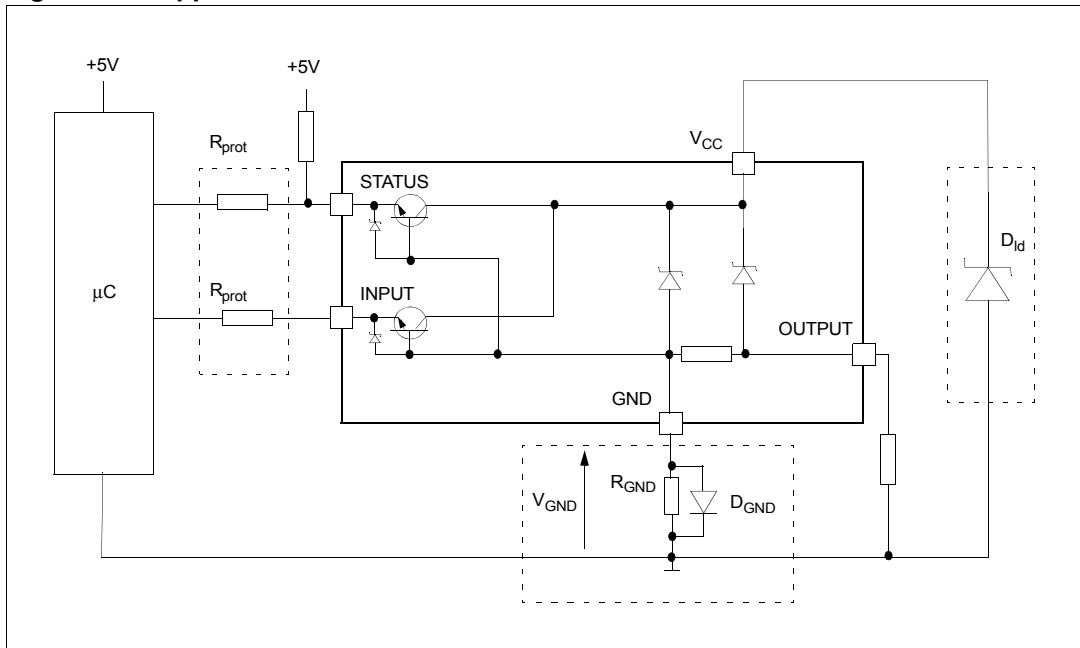

Figure 24. Application schematic



## 2.5 GND protection network against reverse battery

### 2.5.1 Solution 1: resistor in the ground line (R<sub>GND</sub> only)

This can be used with any type of load.

The following is an indication on how to dimension the R<sub>GND</sub> resistor.

1.  $R_{GND} \leq 600\text{mV} / (I_{S(on)max})$ .
2.  $R_{GND} \geq (-V_{CC}) / (-I_{GND})$

where -I<sub>GND</sub> is the DC reverse ground pin current and can be found in the absolute maximum rating section of the device datasheet.

Power Dissipation in R<sub>GND</sub> (when V<sub>CC</sub><0: during reverse battery situations) is:

$$P_D = (-V_{CC})^2 / R_{GND}$$

This resistor can be shared amongst several different HSDs. Please note that the value of this resistor should be calculated with formula (1) where I<sub>S(on)max</sub> becomes the sum of the maximum on-state currents of the different devices.

Please note that if the microprocessor ground is not shared by the device ground then the R<sub>GND</sub> produces a shift (I<sub>S(on)max</sub> \* R<sub>GND</sub>) in the input thresholds and the status output values. This shift varies depending on how many devices are ON in the case of several high side drivers sharing the same R<sub>GND</sub>.

If the calculated power dissipation leads to a large resistor or several devices have to share the same resistor then ST suggests to utilize Solution 2 (see below).

## 2.5.2 Solution 2: diode ( $D_{GND}$ ) in the ground line

A resistor ( $R_{GND}=1\text{ k}\Omega$ ) should be inserted in parallel to  $D_{GND}$  if the device drives an inductive load.

This small signal diode can be safely shared amongst several different HSDs. Also in this case, the presence of the ground network produces a shift ( $\approx 600\text{mV}$ ) in the input threshold and in the status output values if the microprocessor ground is not common to the device ground. This shift not varies if more than one HSD shares the same diode/resistor network.

Series resistor in input and status lines are also required to prevent that, during battery voltage transient, the current exceeds the absolute maximum rating.

Safest configuration for unused input and status pin is to leave them unconnected.

## 2.6 Load dump protection

$D_{ld}$  is necessary (voltage transient suppressor) if the load dump peak voltage exceeds the  $V_{CC}$  max DC rating. The same applies if the device is subject to transients on the  $V_{CC}$  line that are greater than the ones shown in the ISO T/R 7637/1 table.

## 2.7 Microcontroller I/Os protection

If a ground protection network is used and negative transient are present on the  $V_{CC}$  line, the control pins is pulled negative. ST suggests to insert a resistor ( $R_{prot}$ ) in line to prevent the  $\mu\text{C}$  I/Os pins to latch-up.

The value of these resistors is a compromise between the leakage current of  $\mu\text{C}$  and the current required by the HSD I/Os (Input levels compatibility) with the latch-up limit of  $\mu\text{C}$  I/Os.

$$-V_{CCpeak}/I_{latchup} \leq R_{prot} \leq (V_{OH\mu C} - V_{IH} - V_{GND}) / I_{IHmax}$$

Calculation example:

For  $V_{CCpeak} = -100\text{ V}$  and  $I_{latchup} \geq 20\text{ mA}$ ;  $V_{OH\mu C} \geq 4.5\text{ V}$

$$5\text{ k}\Omega \leq R_{prot} \leq 65\text{ k}\Omega$$

Recommended values:  $R_{prot} = 10\text{ k}\Omega$ .

## 2.8 Open-load detection in off-state

Off-state open-load detection requires an external pull-up resistor ( $R_{PU}$ ) connected between output pin and a positive supply voltage ( $V_{PU}$ ) like the +5 V line used to supply the microprocessor.

The external resistor has to be selected according to the following requirements:

- no false open-load indication when load is connected: in this case we have to avoid  $V_{OUT}$  to be higher than  $V_{OLmin}$ ; this results in the following condition  

$$V_{OUT} = (V_{PU} / (R_L + R_{PU})) R_L < V_{OLmin}$$
- no misdetection when load is disconnected: in this case the  $V_{OUT}$  has to be higher than  $V_{OLmax}$ ; this results in the following condition  $R_{PU} < (V_{PU} - V_{OLmax}) / I_{L(off2)}$ .

Because  $I_{s(OFF)}$  may significantly increase if  $V_{out}$  is pulled high (up to several mA), the pull-up resistor  $R_{PU}$  should be connected to a supply that is switched off when the module is in standby.

The values of  $V_{OLmin}$ ,  $V_{OLmax}$  and  $I_{L(off2)}$  are available in the electrical characteristics section.

**Figure 25. Open-load detection in off-state**

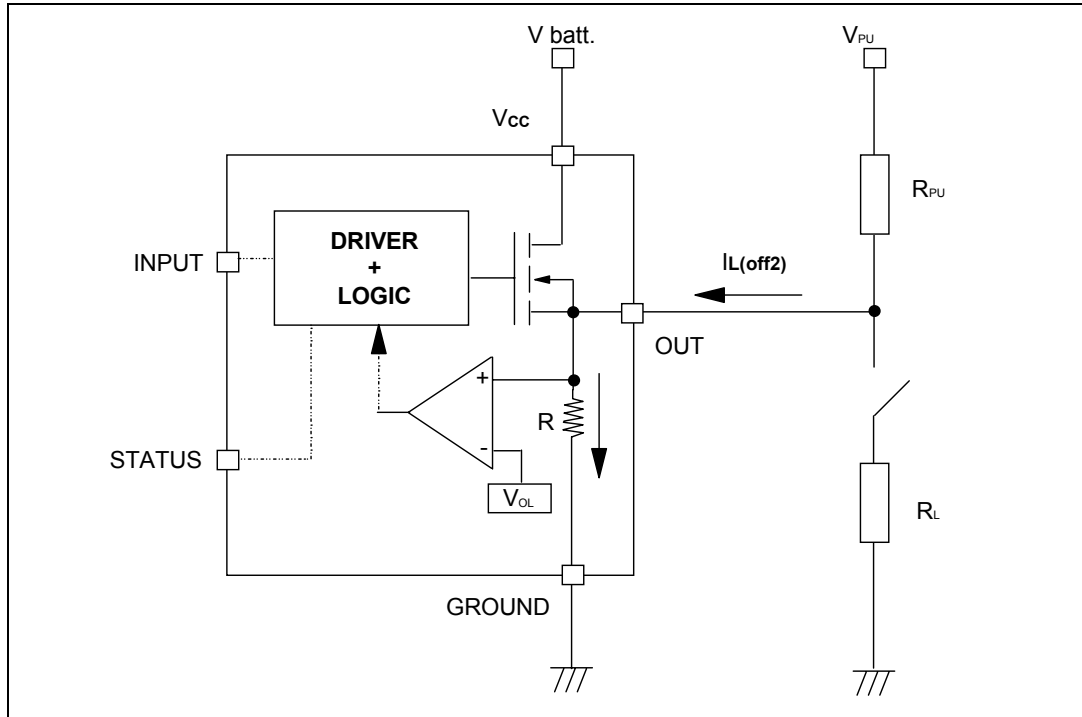

## 2.9 SO-8 maximum demagnetization energy ( $V_{CC} = 13.5\text{ V}$ )

Figure 26. SO-8 maximum turn-off current versus inductance

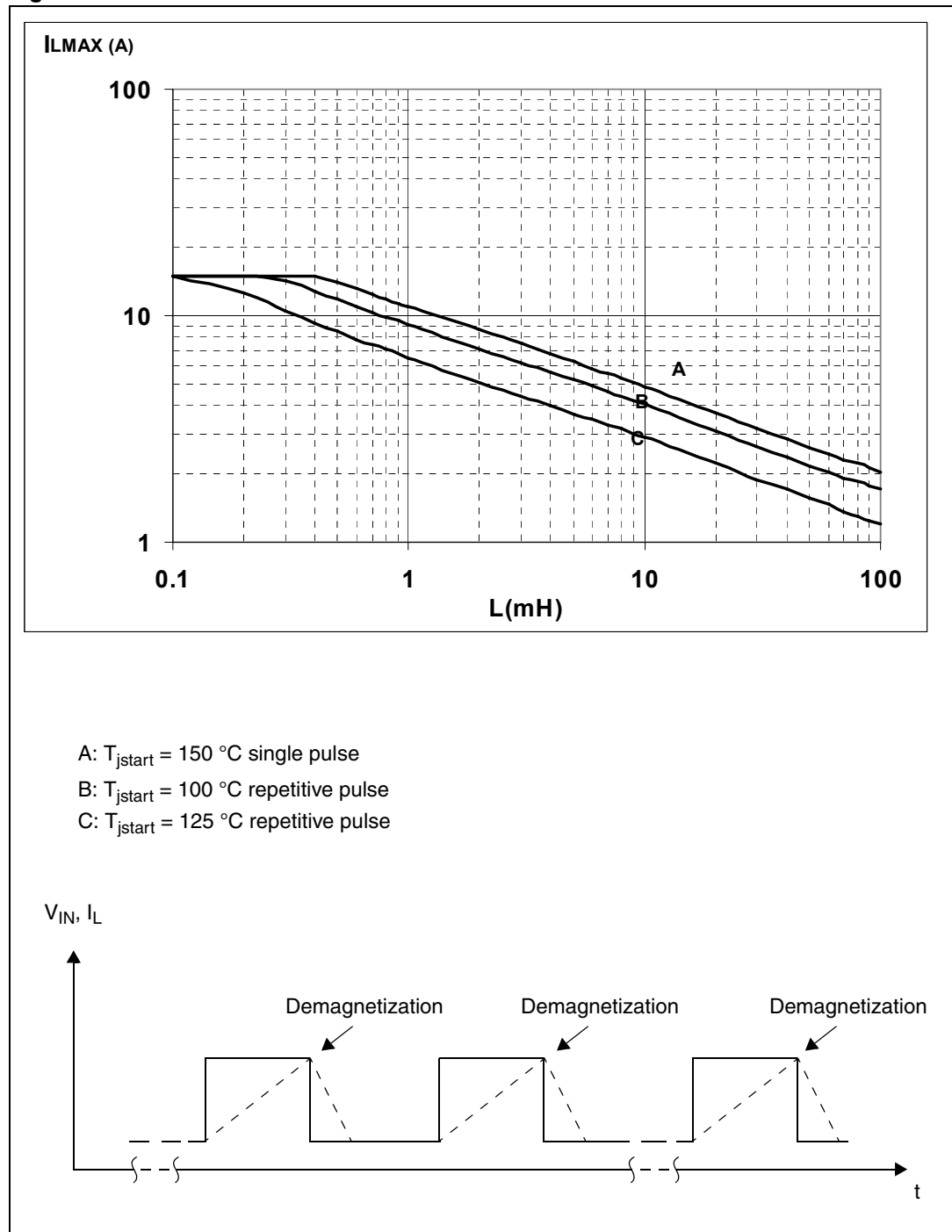

Note: Values are generated with  $R_L = 0\ \Omega$ . In case of repetitive pulses,  $T_{jstart}$  (at beginning of each demagnetization) of every pulse must not exceed the temperature specified above for curves B and C.

### 3 Package and PCB thermal data

#### 3.1 SO-8 thermal data

Figure 27. SO-8 PC board

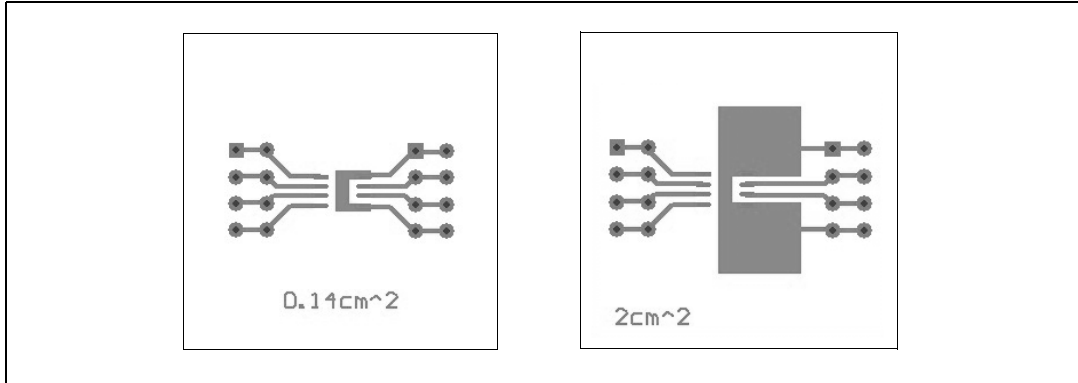

Note: Layout condition of  $R_{th}$  and  $Z_{th}$  measurements (PCB FR4 area = 58 mm x 58 mm, PCB thickness = 2 mm, Cu thickness=35  $\mu$ m, Copper areas: 0.14 cm<sup>2</sup>, 2 cm<sup>2</sup>).

Figure 28.  $R_{thj-amb}$  vs PCB copper area in open box free air condition

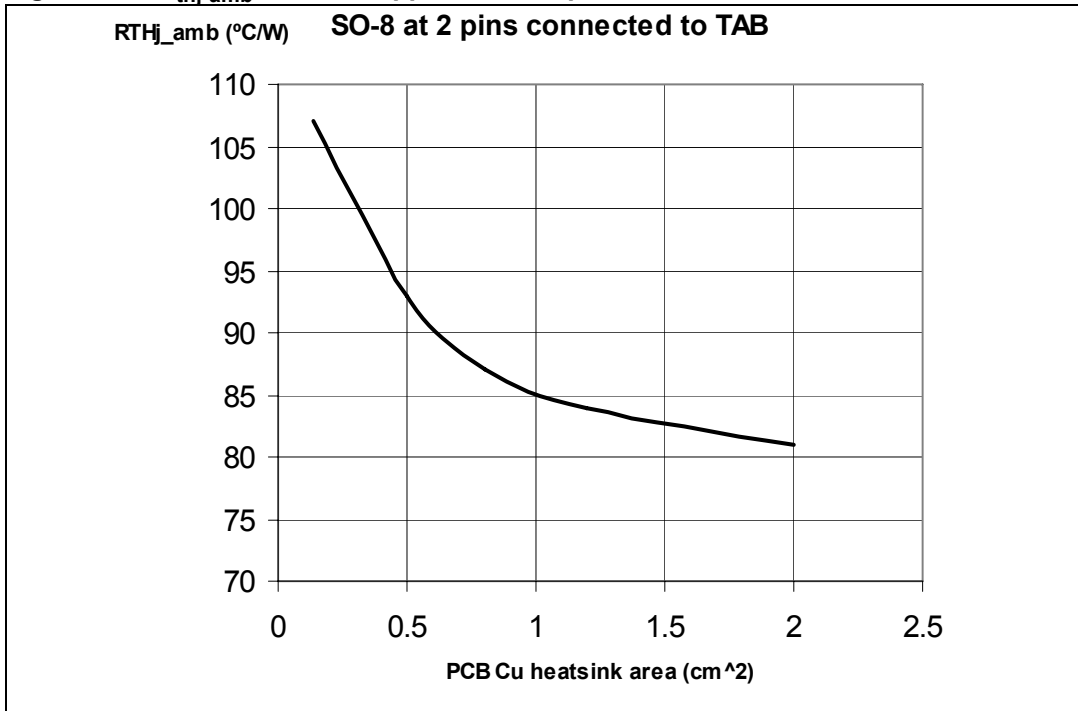
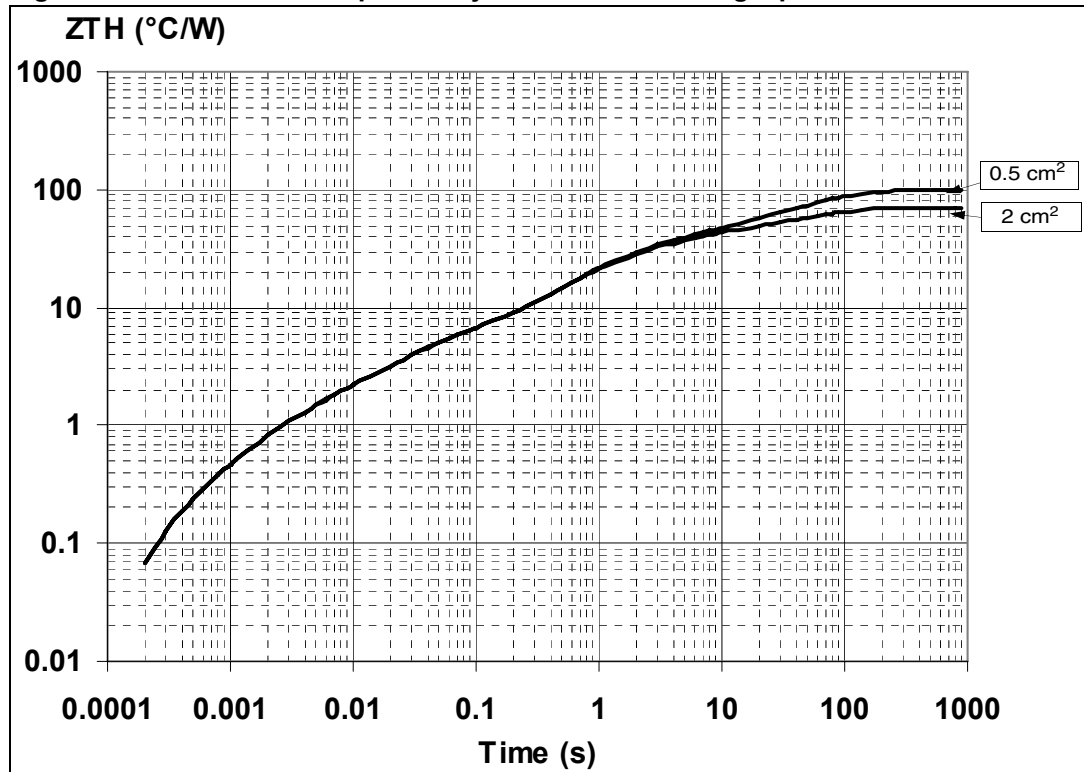

Figure 29. SO-8 thermal impedance junction ambient single pulse



Equation 1: pulse calculation formula

$$Z_{TH\delta} = R_{TH} \cdot \delta + Z_{THtp}(1 - \delta)$$

where  $\delta = t_p/T$

Figure 30. SO-8 thermal fitting model of a single channel

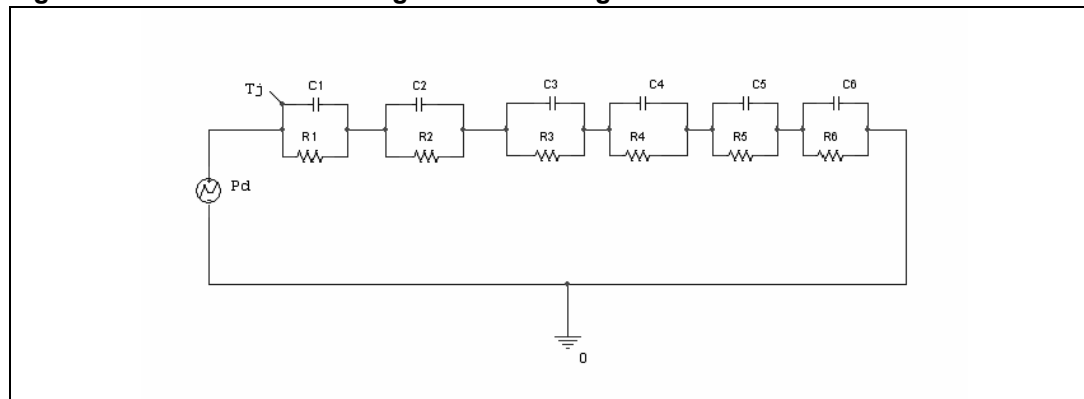

Table 16. SO-8 thermal parameter

Area/island (cm <sup>2</sup> )	0.5	2
R1 (°C/W)	0.05	
R2 (°C/W)	0.8	
R3 (°C/W)	3.5	

Table 16. SO-8 thermal parameter (continued)

Area/island (cm <sup>2</sup> )	0.5	2
R4 (°C/W)	21	
R5 (°C/W)	16	
R6 (°C/W)	58	28
C1 (W·s/°C)	0.006	
C2 (W·s/°C)	2.60E-03	
C3 (W·s/°C)	0.0075	
C4 (W·s/°C)	0.045	
C5 (W·s/°C)	0.35	
C6 (W·s/°C)	1.05	2

## 4 Package and packing information

### 4.1 ECOPACK® packages

In order to meet environmental requirements, ST offers these devices in different grades of ECOPACK® packages, depending on their level of environmental compliance. ECOPACK® specifications, grade definitions and product status are available at: [www.st.com](http://www.st.com).

ECOPACK® is an ST trademark.

### 4.2 SO-8 mechanical data

Figure 31. SO-8 package dimensions

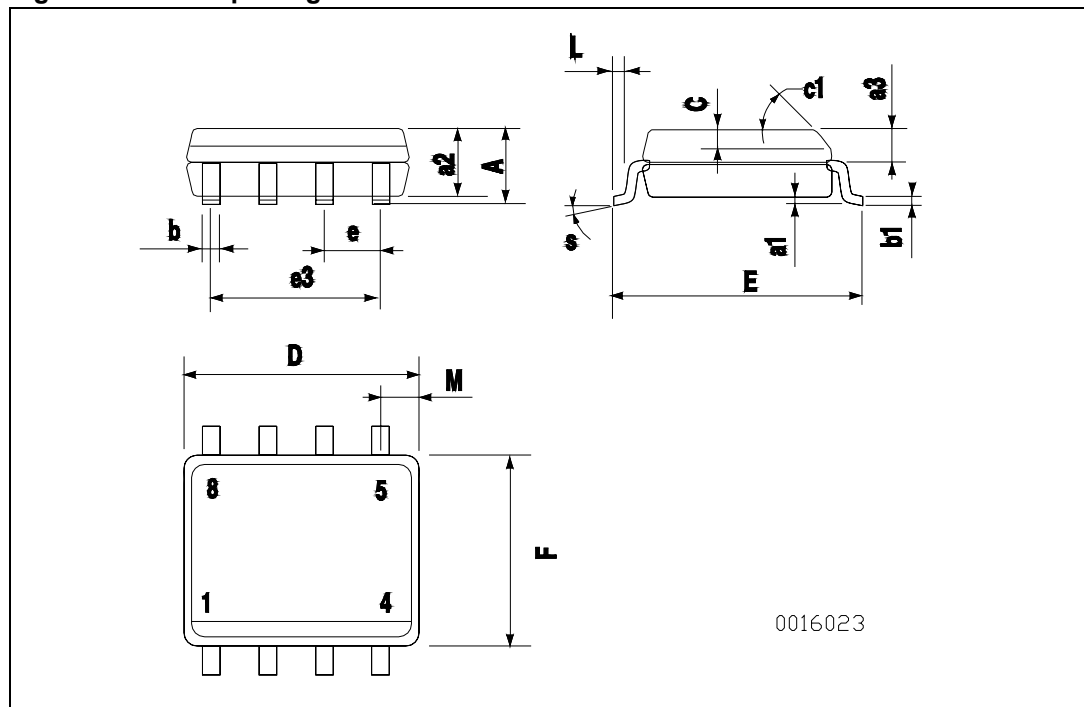

Table 17. SO-8 mechanical data

Dim.	Millimeter		
	Min.	Typ.	Max.
A			1.75
a1	0.1		0.25
a2			1.65
a3	0.65		0.85
b	0.35		0.48
b1	0.19		0.25

Table 17. SO-8 mechanical data (continued)

Dim.	Millimeter		
	Min.	Typ.	Max.
C	0.25		0.5
c1	45 (typ.)		
D	4.8		5
E	5.8		6.2
e		1.27	
e3		3.81	
F	3.8		4
L	0.4		1.27
M			0.6
S	8 (max.)		
L1	0.8		1.2

### 4.3 Packing information

Figure 32. SO-8 tube shipment (no suffix)

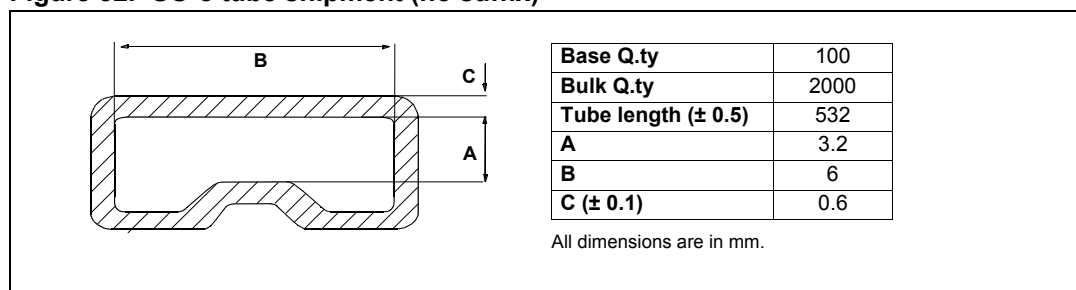
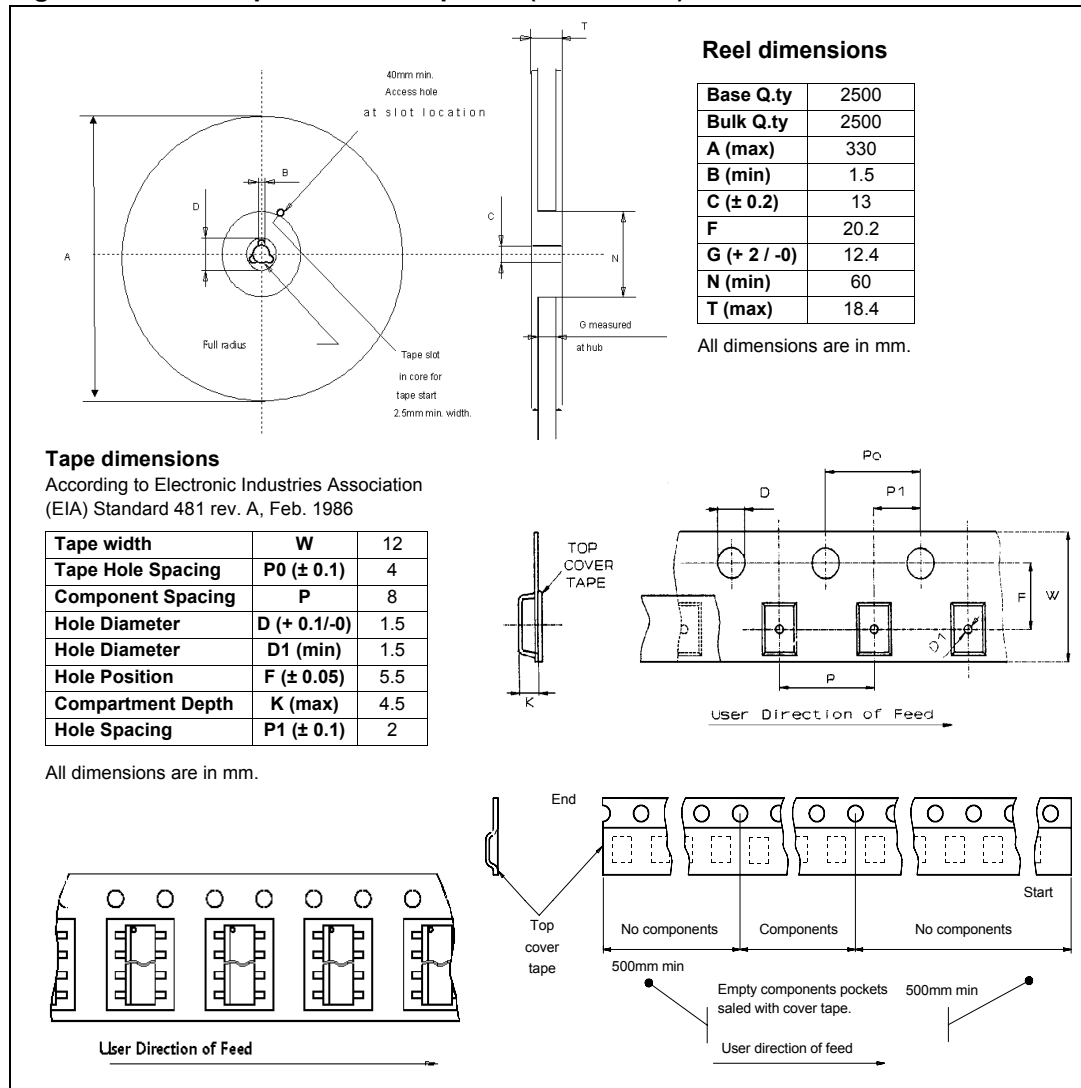

Figure 33. SO-8 tape and reel shipment (suffix "TR")



## 5 Revision history

**Table 18. Document revision history**

Date	Revision	Changes
18-Nov-2009	1	Initial release.

**Please Read Carefully:**

Information in this document is provided solely in connection with ST products. STMicroelectronics NV and its subsidiaries ("ST") reserve the right to make changes, corrections, modifications or improvements, to this document, and the products and services described herein at any time, without notice.

All ST products are sold pursuant to ST's terms and conditions of sale.

Purchasers are solely responsible for the choice, selection and use of the ST products and services described herein, and ST assumes no liability whatsoever relating to the choice, selection or use of the ST products and services described herein.

No license, express or implied, by estoppel or otherwise, to any intellectual property rights is granted under this document. If any part of this document refers to any third party products or services it shall not be deemed a license grant by ST for the use of such third party products or services, or any intellectual property contained therein or considered as a warranty covering the use in any manner whatsoever of such third party products or services or any intellectual property contained therein.

**UNLESS OTHERWISE SET FORTH IN ST'S TERMS AND CONDITIONS OF SALE ST DISCLAIMS ANY EXPRESS OR IMPLIED WARRANTY WITH RESPECT TO THE USE AND/OR SALE OF ST PRODUCTS INCLUDING WITHOUT LIMITATION IMPLIED WARRANTIES OF MERCHANTABILITY, FITNESS FOR A PARTICULAR PURPOSE (AND THEIR EQUIVALENTS UNDER THE LAWS OF ANY JURISDICTION), OR INFRINGEMENT OF ANY PATENT, COPYRIGHT OR OTHER INTELLECTUAL PROPERTY RIGHT.**

**UNLESS EXPRESSLY APPROVED IN WRITING BY AN AUTHORIZED ST REPRESENTATIVE, ST PRODUCTS ARE NOT RECOMMENDED, AUTHORIZED OR WARRANTED FOR USE IN MILITARY, AIR CRAFT, SPACE, LIFE SAVING, OR LIFE SUSTAINING APPLICATIONS, NOR IN PRODUCTS OR SYSTEMS WHERE FAILURE OR MALFUNCTION MAY RESULT IN PERSONAL INJURY, DEATH, OR SEVERE PROPERTY OR ENVIRONMENTAL DAMAGE. ST PRODUCTS WHICH ARE NOT SPECIFIED AS "AUTOMOTIVE GRADE" MAY ONLY BE USED IN AUTOMOTIVE APPLICATIONS AT USER'S OWN RISK.**

Resale of ST products with provisions different from the statements and/or technical features set forth in this document shall immediately void any warranty granted by ST for the ST product or service described herein and shall not create or extend in any manner whatsoever, any liability of ST.

ST and the ST logo are trademarks or registered trademarks of ST in various countries.

Information in this document supersedes and replaces all information previously supplied.

The ST logo is a registered trademark of STMicroelectronics. All other names are the property of their respective owners.

© 2009 STMicroelectronics - All rights reserved

STMicroelectronics group of companies

Australia - Belgium - Brazil - Canada - China - Czech Republic - Finland - France - Germany - Hong Kong - India - Israel - Italy - Japan - Malaysia - Malta - Morocco - Philippines - Singapore - Spain - Sweden - Switzerland - United Kingdom - United States of America

[www.st.com](http://www.st.com)