

Multiple multifunction voltage regulator for car radio

Features

- 2 stand-by regulators:
3.3V (125mA)
1.5V (300mA)
- 6 regulators:
10V (40mA)
8.5V (200mA)
3.3V (850mA)
8/10V (1A)
5/3.3/1.8V (200mA)
1.8/2.5V(200mA)
- All regulators are low dropout outputs
- The different outputs voltage are controlled by I²C Bus.
- Reg3 on/off controlled by enable
- Reg1, Reg2, Reg4, Reg5, Reg6 on/off controlled by I²C Bus.
- 3 high side drivers:
2A (HSD1)
0.45A (HSD2 & HSD3)
- No external charge pump capacitors are required
- Stand-by mode controlled by EN pin for I²C Bus and Reg1, Reg2, Reg3, Reg4, Reg5, Reg6, HSD1, HSD2, HSD3
- LVW function externally selectable
- Individual thermal shutdown

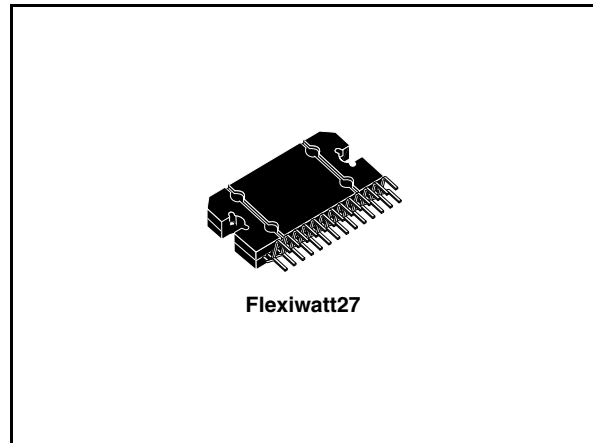

- Independent current limiting
- Short circuit protection
- Load dump protection and overvoltage shutdown

Description

The L5955 is an integration of three high side drivers, six regulators and two stand-by regulators with RESET function developed to provide the power to a complete audio system.

The outputs of the IC are controlled by I²C bus and Enable pin.

The device is equipped with sequencing and slew rate controls for the st-by regulators.

Table 1. Device summary

Order code	Package	Packing
L5955	Flexiwatt27	Tube

Contents

- 1 Block and pin connection diagrams 3**

- 2 Electrical specification 4**
 - 2.1 Absolute maximum ratings 4
 - 2.2 Thermal data 4
 - 2.3 Electrical characteristics 4

- 3 Functional description 10**
 - 3.1 Write mode: 12
 - 3.2 Chip address byte: 13
 - 3.3 Data byte: 13

- 4 Package information 15**

- 5 Revision history 16**

1 Block and pin connection diagrams

Figure 1. Block diagram

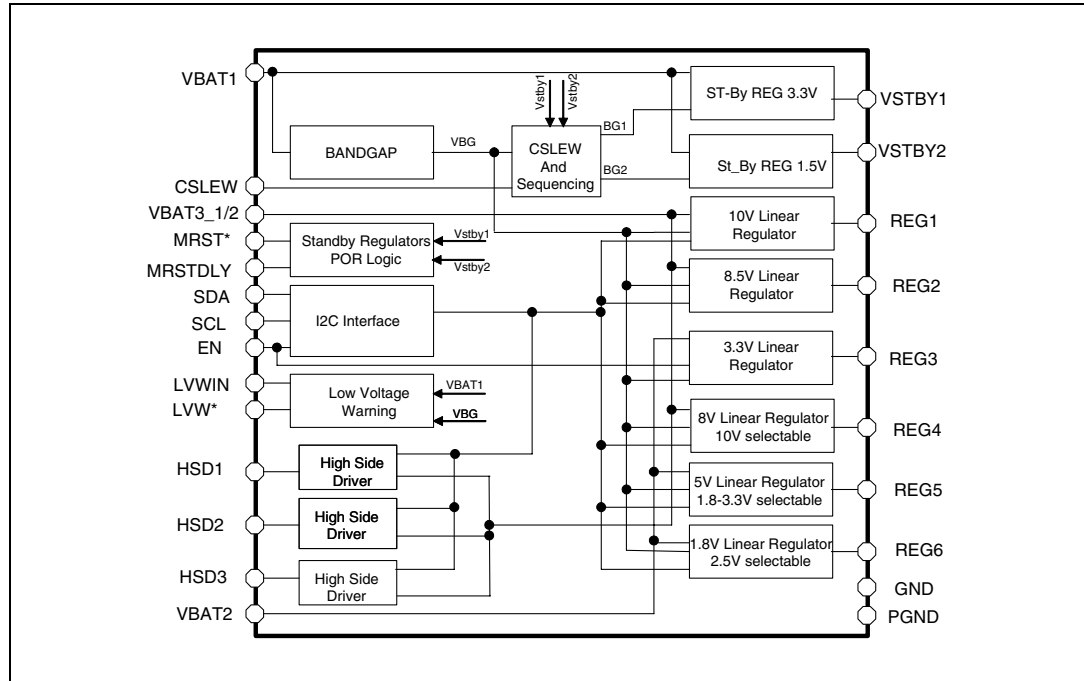
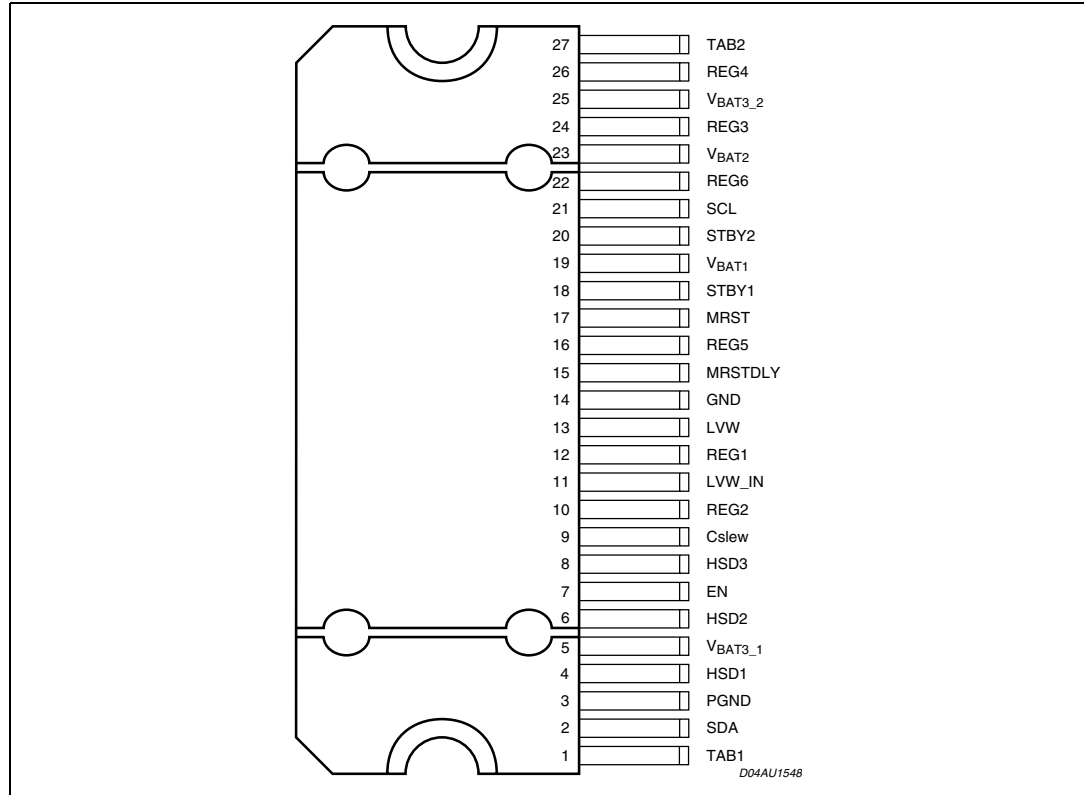

Figure 2. Pin connection (top view)



2 Electrical specification

2.1 Absolute maximum ratings

Table 2. Absolute maximum ratings

Symbol	Parameter	Value	Unit
VS1, VS2, VS3_1, VS3_2	DC operating supply voltage	0.6 to 26.5	V
VS1, VS2, VS3_1, VS3_2	Transient supply over voltages, rise time = 10ms delay time = 115ms	34	V
$V_{S1,2,3,1,3_2,ovs}$	Overvoltage shutdown	27	V
V_{in}	Input voltages (EN, SDA, SCL, LVW, MRST, MRSTDLY, CSLEW)	-0.6 to 5.5	V
V_{out}	Output control voltage	-0.6 to 18	V
T_{op}	Operating temperature range	-40 to 85	°C
T_{stg}	Storage temperature range	-40 to 150	°C

2.2 Thermal data

Table 3. Thermal data

Symbol	Parameter	Value	Unit
$R_{th\ j-case}$	Thermal resistance junction to case	1	°C/W

2.3 Electrical characteristics

Table 4. Electrical characteristics

(Refer to the application circuit, $V_{bat} = V_{bat1} + V_{bat2} + V_{bat3} = 14V$, $I_{ST-BY1} = 0.5mA$, $I_{ST-BY2} = 0.5mA$, $I_{REG1} = I_{REG2} = I_{REG3} = I_{REG4} = I_{REG5} = I_{REG6} = 5mA$, $R_{HSD1} = R_{HSD2} = R_{HSD3} = 16\Omega$)

Symbol	Parameter	Test condition	Min.	Typ.	Max.	Unit
I_{qST-BY}	Stand-by quiescent current	$V_{bat} = 14V$, $EN = 0$. $I_{ST-BY1} = I_{ST-BY2} = 100\mu A$, $I_Q(V_{bat}) = I_{V_{bat1}} + I_{V_{bat2}} + I_{V_{bat3}}$			170	μA
I_q	Maximum quiescent current	$V_{bat} = 14V$, $EN = V_{STBY1}$ $I_{STBY1} = 125mA$ $I_{STBY2} = 300mA$ $I_{REG1} = 40mA$ $I_{REG2} = 200mA$, $I_{REG3} = 850mA$ $I_{REG4} = 1A$, $I_{REG5} = 250mA$ $I_{REG6} = 200mA$, $I_{HSD1} = 2A$ $I_{HSD2,3} = 450mA$		100		mA
I_{EN}	Enable input current	$V_{bat} = 14V$; $5V < Enable \leq 0V$;			10	μA
V_{IL} V_{IH}	Enable threshold voltage	$V_{bat} = 14V$;	2		0.8	V V
$V_{L MRST}$	MRST output voltage	$V_{ST-BY1} = 0.5V$ to V_{TH} (ST-BY1) $V_{ST-BY2} = 0.5V$ to V_{TH} (ST-BY2) Rising	0 0		0.4 0.4	V
$V_{H MRST}$		$V_{ST-BY1} = V_{TH}$ (ST-BY1) to $0.5V$ $V_{ST-BY2} = V_{TH}$ (ST-BY2) to $0.5V$ Falling	0 0		0.4 0.4	V
$V_{TH MRST}$	MRST output voltage threshold	Force V_{ST-BY1} & V_{ST-BY2} Low until MRST asserted	$V_{ST-BY2} \cdot 0.93$ $V_{ST-BY1} \cdot 0.93$		$V_{ST-BY2} \cdot 0.97$ $V_{ST-BY1} \cdot 0.97$	V V
$t_{d MRST}$	MRST delay time	see Figure 4		13		μs
$t_{por MRST}$	Power on reset delay time	$C_{MRSTLY} = 220nF$ see Figure 4	20			ms
$t_f MRST$	MRST fall time	$R_{RST} = 47k\Omega$, $C_{RST} = 50pF$ see Figure 4			1	μs
$I_{SCR MRST}$	MRSTDLY current	$MRSTDLY = 0$	6		12	μA
$I_{LKG MRSTDLY}$	MRSTDLY leakage current	$MRSTDLY = 5V$			6	μA
$V_{sat MRSTDLY}$	MRSTDLY saturation voltage	$I_{MRSTDLY} = 0.5mA$	0		0.4	V
V_{TH}	LVWIN input voltage threshold	1.25 V (nominal)	1.22		1.28	V
I_{LKG}	lvwin input leakage current				2	μA
V_{OH}	LVW output voltage	$I_{OH} = -100\mu A$	$V_{STBY1} - 0.2$		V_{STBY1}	V

Table 4. Electrical characteristics (continued)

(Refer to the application circuit, $V_{bat} = V_{bat1} + V_{bat2} + V_{bat3} = 14V$, $I_{ST-BY1} = 0.5mA$, $I_{ST-BY2} = 0.5mA$, $I_{REG1} = I_{REG2} = I_{REG3} = I_{REG4} = I_{REG5} = I_{REG6} = 5mA$, $R_{HSD1} = R_{HSD2} = R_{HSD3} = 16\Omega$)

Symbol	Parameter	Test condition	Min.	Typ.	Max.	Unit
V_{OL}	LVW output voltage	$I_{OL} = 100\mu A$	0		0.2	V
T_S	Thermal shutdown for HSDS, REGS, V_{ST-BY1} , V_{ST-BY2}	HSDS, REGS, V_{ST-BY1} , V_{ST-BY2} min. load. Increase T_{amb} until HSDS, REGS, $V_{ST-BY1,2}$ Disabled		170		$^{\circ}C$
$T_{S\ HYS}$	Thermal shutdown hysteresis for HSDS, REGS, V_{ST-BY1} , V_{ST-BY2}	HSDS, REGS, V_{ST-BY1} , V_{ST-BY2} min. load. Decrease T_{amb} until HSDS, REGS, $V_{ST-BY1,2}$ Disabled		10		$^{\circ}C$
I_o	CSLEW output current		7		14	μA
t_{on}	ST-BY1, ST-BY2. minimum turn on time	$C_{SLEW} = 7nF$; see Figure 5	1.6			ms
3.3V/125mA V_{ST-BY1}						
V_{ST-BY1}	Output voltage	$I_{ST-BY1} = 125mA$	3.14		3.46	V
ΔV_{line}	Line regulation	$7V \leq V_{BAT} \leq 18V$ (Measure ΔV_{reg1} across V_{BAT} range)			10	mV
ΔV_{load}	Load regulation	$0.5mA \leq I_{ST-BY1} \leq 125mA$ (Measure ΔV_{reg1} across V_{BAT} range)			50	mV
I_{q1}	Δ Quiescent current (measure ΔI_{BAT})	$I_{ST-BY1} = 2mA$, $V_{BAT} = 14V$, $I_{ST-BY1} = 125mA$, $V_{BAT} = 14V$			150 10	μA mA
$V_{DROPOUT}$	Dropout voltage (measure $V_{BAT} - V_{ST-BY1}$ when V_{ST-BY1} drops 0.1V)	$I_{ST-BY1} = 125mA$ $I_{ST-BY1} = 5mA$			2.6 1.2	V V
I_{lim1}	Current limit		160		350	mA
ΔV_{lead}	V_{ST-BY1} absolute differential output voltage	force V_{ST-BY2} Low; Measure $V_{ST-BY1} - V_{ST-BY2}$			2.5	V
ΔV_{lag}		force V_{ST-BY1} Low; Measure $V_{ST-BY1} - V_{ST-BY2}$			0.25	V
SVR1	Supply voltage rejection ST-BY1	$f_o = 120-10kHz$, $V_{BAT} = 14V$ with 1.0Vp-p AC,	50			dB
		$f_o = 20-20kHz$, $V_{BAT} = 14V$ with 1.0Vp-p AC	45			dB
1.5V/300mA V_{ST-BY2}						
V_{ST-BY2}	Output voltage	$I_{ST-BY2} = 300mA$	1.425		1.575	V
ΔV_{line}	Line regulation	$7V \leq V_{BAT} \leq 18V$ (measure ΔV_{ST-BY2} across V_{BAT} range)			50	mV

Table 4. Electrical characteristics (continued)

(Refer to the application circuit, $V_{bat} = V_{bat1} + V_{bat2} + V_{bat3} = 14V$, $I_{ST-BY1} = 0.5mA$, $I_{ST-BY2} = 0.5mA$, $I_{REG1} = I_{REG2} = I_{REG3} = I_{REG4} = I_{REG5} = I_{REG6} = 5mA$, $R_{HSD1} = R_{HSD2} = R_{HSD3} = 16\Omega$)

Symbol	Parameter	Test condition	Min.	Typ.	Max.	Unit
ΔV_{load}	Load regulation	$0.5mA \leq I_{ST-BY2} \leq 300mA$			100	mV
$V_{DROPOUT}$	Dropout voltage (measure $V_{BAT} - V_{ST-BY2}$ when V_{ST-BY2} drops 0.1V)	$I_{ST-BY2} = 300mA$ $I_{ST-BY2} = 5mA$			4.1 3	V V
I_{lim2}	Current limit		360		700	mA
SVR3	Supply voltage rejection ST-BY2	$f_o = 120-10kHz$, $V_{BAT} = 14V$ with 1.0Vp-p AC, $f_o = 20-20kHz$, $V_{BAT} = 14V$ with 1.0Vp-p AC	50			dB
			45			dB
10V/40mA REG1 output						
V_{REG1}	Output voltage	$I_{REG1} = 40mA$	9.50	10	10.5	V
ΔV_{line}	Line regulation	$11.4V \leq V_{BAT} \leq 18V$ (measure ΔV_{REG1} across V_{BAT} range)			55	mV
ΔV_{load}	Load regulation	$5mA \leq I_{REG1} \leq 40mA$			55	mV
$V_{DROPOUT}$	Dropout voltage (measure $V_{BAT} - V_{REG1}$ when V_{REG1} drops 0.1V)	$I_{REG1} = 40mA$ $I_{REG1} = 5mA$			1200	mV
					300	mV
I_{lim1}	Current limit		60		200	mA
SVR	Supply voltage rejection (guaranteed by characterization-test at 1kHz with 50dB Limit)		50			dB
8.5V/200mA REG2 output						
V_{REG2}	Output voltage	$I_{REG2} = 200mA$	8.3	8.5	8.7	V
ΔV_{line}	Line regulation	$9.6V \leq V_{BAT} \leq 18V$ (measure ΔV_{REG2} across V_{BAT} range)			50	mV
ΔV_{load}	Load regulation	$5mA \leq I_{REG2} \leq 200mA$			50	mV
$V_{DROPOUT}$	Dropout voltage (measure $V_{BAT} - V_{REG2}$ when V_{REG2} drops 0.1V)	$I_{REG2} = 200mA$ $I_{REG2} = 5mA$			1100	mV
					600	mV
I_{lim2}	Current limit		225		525	mA
SVR	Ripple rejection (guaranteed By characterization-test at 1kHz with 50dB limit)		50			dB
3.3V/850mA REG3 output						
V_{REG3}	Output voltage	$I_{REG3} = 850mA$	3.14		3.46	V
ΔV_{line}	Line regulation	$7V \leq V_{BAT} \leq 18V$ (Measure ΔV_{REG2} Across V_{BAT} range)			40	mV
ΔV_{load}	Load regulation	$5mA \leq I_{REG3} \leq 850mA$			100	mV
$V_{DROPOUT}$	Dropout voltage (measure $V_{BAT} - V_{REG3}$ when V_{REG3} drops 0.1V)	$I_{REG3} = 850mA$ $I_{REG3} = 5mA$			3.46	V
					2.86	V

Table 4. Electrical characteristics (continued)

(Refer to the application circuit, $V_{bat} = V_{bat1} + V_{bat2} + V_{bat3} = 14V$, $I_{ST-BY1} = 0.5mA$, $I_{ST-BY2} = 0.5mA$, $I_{REG1} = I_{REG2} = I_{REG3} = I_{REG4} = I_{REG5} = I_{REG6} = 5mA$, $R_{HSD1} = R_{HSD2} = R_{HSD3} = 16\Omega$)

Symbol	Parameter	Test condition	Min.	Typ.	Max.	Unit
I_{lim4}	Current limit		1.25		2.5	A
SVR	Ripple rejection (guaranteed by characterization-test at 1kHz with 50dB Limit)		50			dB
8V/10V/1A REG4 output						
V_{REG4}	Output voltage	$I_{REG4} = 1A$	7.6 9.50		8.4 10.5	V V
ΔV_{line}	Line regulation	$11.4V \leq V_{BAT} \leq 18V$, For $V_{REG4}=10V$ $9.3V < V_{BAT} < 18V$ For $V_{REG4}=8V$ (measure ΔV_{REG4} across V_{BAT} range)			50 50	mV mV
ΔV_{load}	Load regulation	$5mA \leq I_{REG4} \leq 1A$			150	mV
$V_{DROPOUT}$	Dropout voltage (measure $V_{BAT} - V_{REG4}$ when V_{REG4} drops 0.1V)	$I_{REG4} = 1A$ $I_{REG4} = 5mA$			1.100 600	mV mV
I_{lim4}	Current limit		1.5		3	A
SVR	Ripple rejection (guaranteed By characterization-test at 1kHz with 50dB Limit)		50			dB
1.8-3.3-5V/250mA REG5 output						
V_{REG5}	Output voltage	$I_{REG5} = 250mA$	1.71 3.14 4.75		1.89 3.46 5.25	V V V
ΔV_{line}	Line regulation	$7V \leq V_{BAT} \leq 18V$ for $V_{REG5}=1.8V, 3.3V$ $9V < V_{BAT} > 18V$ for $V_{REG5}=5V$ (measure ΔV_{REG5} across V_{BAT} range)			40	mV
ΔV_{load}	Load regulation	$5mA \leq I_{REG5} \leq 250mA$			100	mV
$V_{DROPOUT}$	Dropout voltage (measure $V_{BAT} - V_{REG5}$ when V_{REG5} drops 0.1V)	$I_{REG5} = 250mA @ V_{REG5}=1.8V$ $I_{REG5} = 5mA @ V_{REG5}=1.8V$ $I_{REG5} = 250mA @ V_{REG5}=3.3V$ $I_{REG5} = 5mA @ V_{REG5}=3.3V$ $I_{REG5} = 250mA @ V_{REG5}=5V$ $I_{REG5} = 5mA @ V_{REG5}=5V$			4.89 4.29 3.46 2.86 1.85 1.25	V V V V V V
I_{lim5}	Current limit		300		700	mA
SVR	Ripple rejection (guaranteed by characterization-test at 1kHz with 50dB limit)		50			dB

Table 4. Electrical characteristics (continued)

(Refer to the application circuit, $V_{bat} = V_{bat1} + V_{bat2} + V_{bat3} = 14V$, $I_{ST-BY1} = 0.5mA$, $I_{ST-BY2} = 0.5mA$, $I_{REG1} = I_{REG2} = I_{REG3} = I_{REG4} = I_{REG5} = I_{REG6} = 5mA$, $R_{HSD1} = R_{HSD2} = R_{HSD3} = 16\Omega$)

Symbol	Parameter	Test condition	Min.	Typ.	Max.	Unit
1.8-2.5V/200mA REG6 output						
V_{REG6}	Output voltage	$I_{REG6} = 200mA$	1.71 2.38		1.89 2.62	V V
ΔV_{line}	Line regulation	$7V \leq V_{BAT} \leq 18V$ (measure ΔV_{REG6} across V_{BAT} range)			40	mV
ΔV_{load}	Load regulation	$5mA \leq I_{REG6} \leq 200mA$			50	mV
$V_{DROPOUT}$	Dropout voltage (measure $V_{BAT} - V_{REG6}$ when V_{REG6} drops 0.1V)	$I_{REG6} = 200mA @ V_{REG6}=1.8V$ $I_{REG6} = 5mA @ V_{REG6}=1.8V$ $I_{REG6} = 200mA @ V_{REG6}=2.5V$ $I_{REG6} = 5mA @ V_{REG6}=2.5V$			4.89 4.29 4.22 3.62	V V V V
I_{lim6}	Current limit		240		600	mA
SVR	Ripple rejection (guaranteed by characterization-test at 1kHz with 50dB limit)		50			dB
2A HSD1						
V_{sat}	Output saturation voltage	$I_{HSD1} = 1A$ continuous time operation $I_{HSD1}=2A t=5seconds$			0.6 1.2	V V
I_{leak1}	Output leakage current	All Driver Outputs are Off			50	μA
I_{lim}	Current limiting	$R_{HSD1} = 0.5\Omega$	2.4		4	A
0.45A HSD2 & HSD3						
V_{sat}	Output saturation voltage	$I_{HSD2,3} = 300mA$ continuous time operation $I_{HSD2,3}=450mA t=5 seconds$			0.6 1.2	V V
$I_{leak2,3}$	Output leakage current	All driver outputs are Off			50	μA
I_{lim}	Current limiting	$R_{HSD2,3} = 0.5\Omega$	0.550		1	A
Characteristics for I²C						
V_{IL}	LOW level input voltage				1.5	V
V_{IH}	HIGH level input voltage		3			V
V_{HYS}	Input hysteresis		0.2			V
V_{OL1}	LOW level output	Sink current = 3mA			0.4	V
V_{OL1}		Sink current = 6mA			0.6	V
I_1	Input current	$0.5V \leq V_1 \leq 4.5V$			10	μA
f_{SCL}	SCL clock frequency				400	kHz

3 Functional description

The three high side drivers are one 2A output (HSD1) and two 450mA outputs (HSD2 & 3).

The six regulator outputs are 10V at 40mA (REG1), 8.5V at 200mA (REG2), 3.3V at 850mA (REG3), 8/10V at 1A (REG4), 1.8V/3.3V/5V at 250mA (REG5) and 1.8V/2.5V at 200mA (REG6).

The two stand-by regulators are 3.3V at 125mA (ST-BY1) and 1.5V at 300mA (ST-BY2).

ST-BY1 and ST-BY2 are equipped with Reset function.

ST-BY1 and ST-BY2 share one Reset output (MRST).

A slew rate limiter and a sequencing function control ST-BY1 and ST-BY2 turn on/off.

The 8.5V regulator output (REG2) has a tighter tolerance output than the other regulator outputs.

The 8.5V output is a $\pm 2.5\%$ (5% total range) output over temperature to improve performance and reduce cost on the 8.5V output. The other outputs are $\pm 5\%$ over temperature.

The two STAND-BY regulators are switched on/off from battery line.

The REG3 is switched on/off by Enable pin which also activate the I²C BUS.

The other Regulators and HSD's are turned on/off independently by I²C BUS, which also controls the regulators' output voltages.

With ENABLE pin set to 0 the total current sunk from the battery line minimized.

Figure 3. Reset and power-on reset schematic

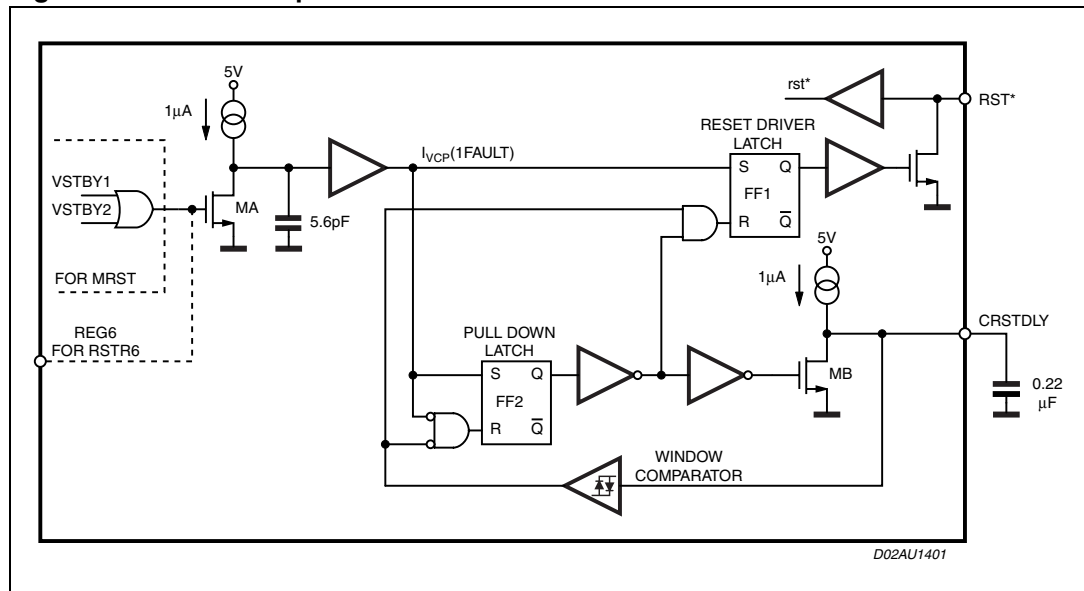

Figure 4. Reset timing

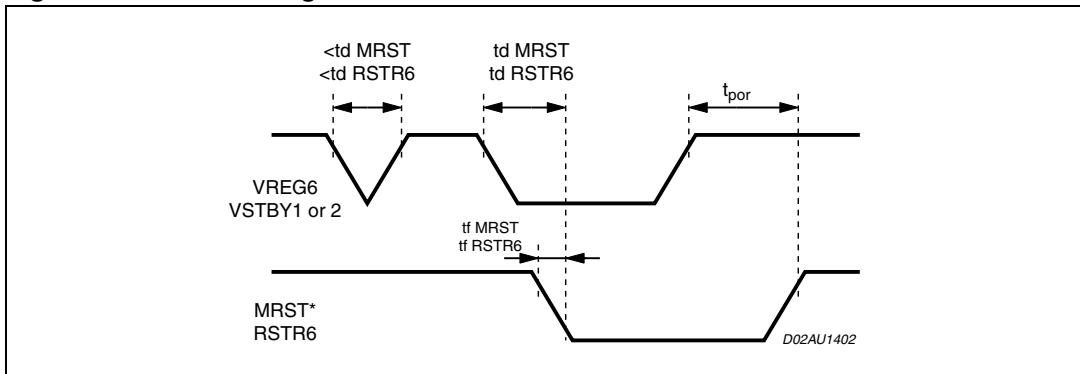

Figure 5. SLEW function

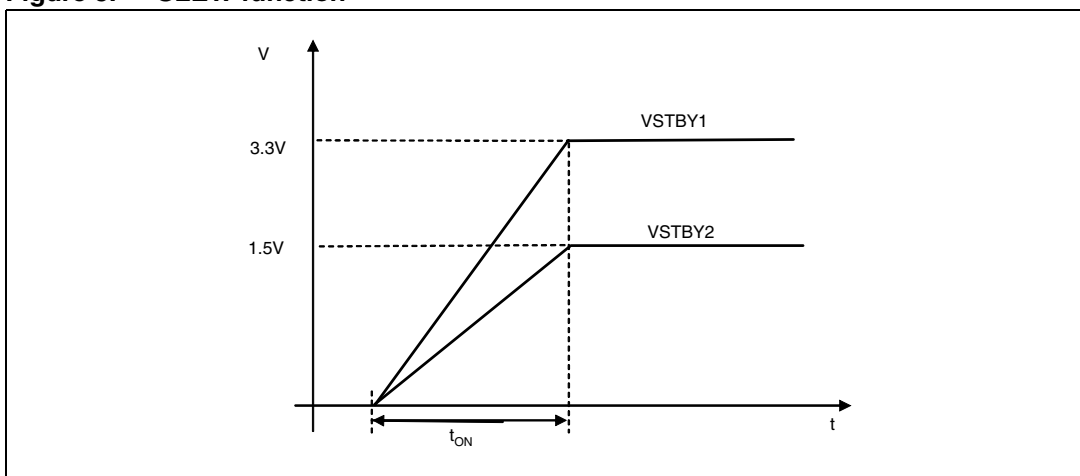

Figure 6. Sequencing function

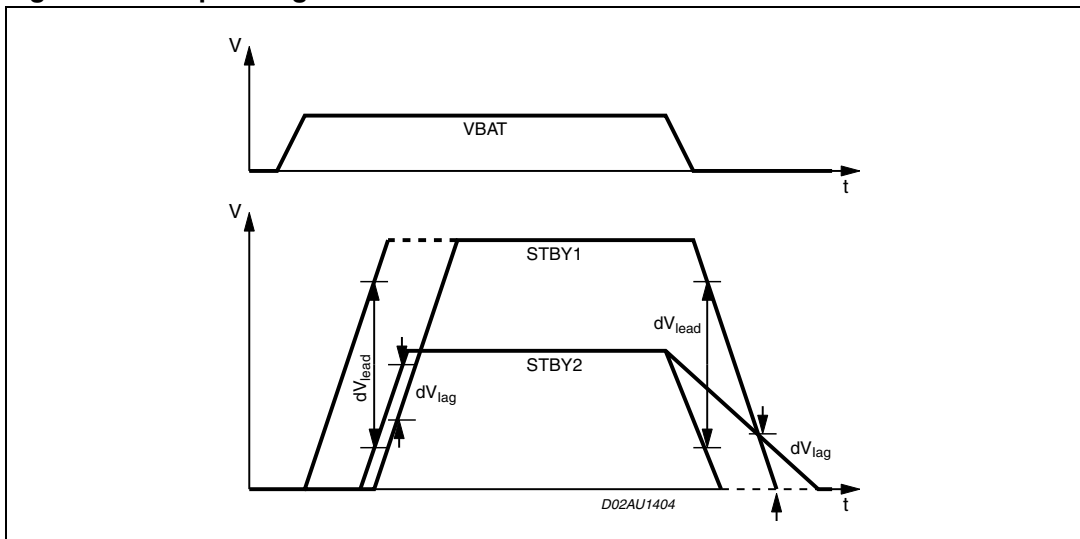

Figure 7. Definition of timing on the I²C Bus.

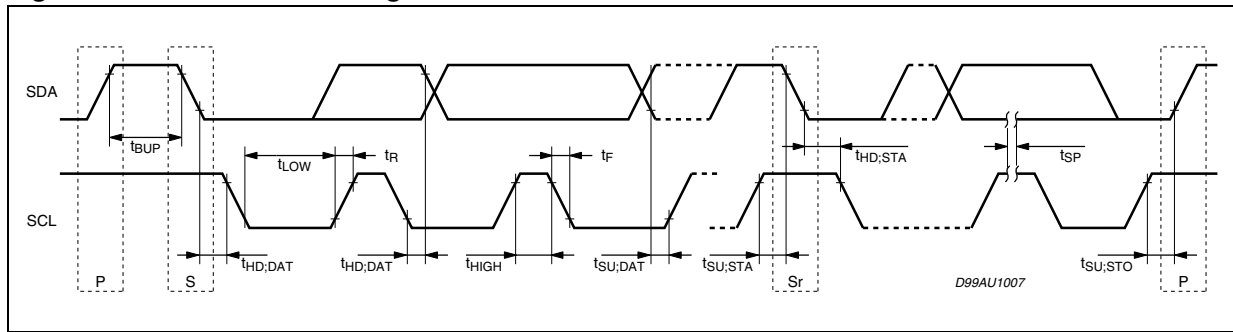
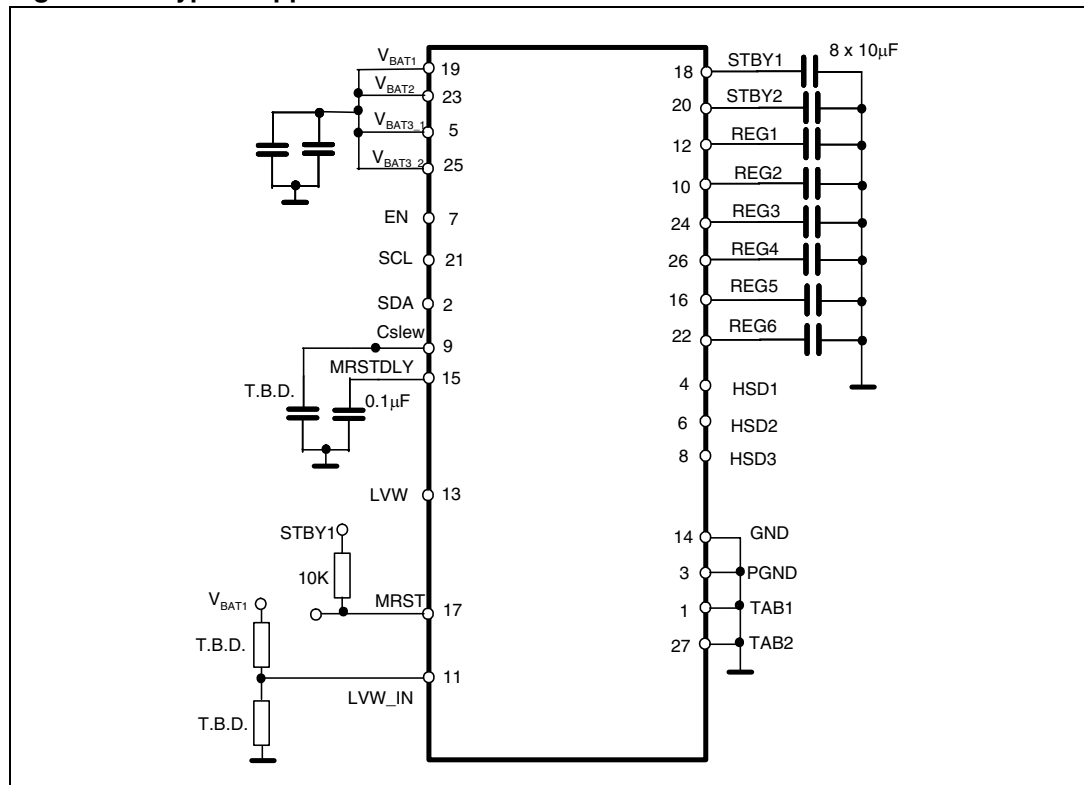
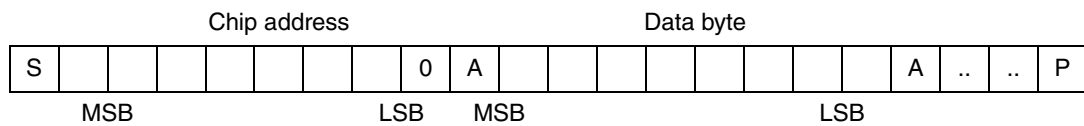

Figure 8. Typical application circuit



3.1 Write mode:



S = START condition - SDA goes from high to low while SCL is high

A = Acknowledge - the device being written to, pulls down on data line (SDA) during the acknowledge clock pulse.

P = STOP condition - SDA goes from low to high while SCL is high.

3.2 Chip address byte:

Table 5. Chip address byte

Chip address							Read/write
A7	A6	A5	A4	A3	A2	A1	A0
0	0	0	1	0	0	0	0

3.3 Data byte:

Table 6. Data byte

b7	b6	b5	b4	b3	b2	b1	b0
Data byte 0							
REG6 SET	REG5 SET2	REG5 SET1	REG4 SET		HSD3EN	HSD2EN0	HSD1EN0
Data byte 1							
	REG6EN	REG5EN	REG4EN		REG2EN	REG1EN	

Default mode is 0000 0000 which corresponds to all outputs being off, low power mode.

Table 7. Data byte 0 description

Name	Description	State	Definition	bit
REG6 SET	REG6 output voltage configuration	0	1.8V	b7
		1	2.5V	b7
REG5 SET1 REG5 SET2	REG5 output voltage configuration	00	5.0V	b5, b6
		01	3.3V	b5, b6
		10	1.8V	b5, b6
		11	x	b5, b6
REG4 SET	REG4 output voltage configuration	0	8.0V	b4
		1	10.0V	b4
HSD3EN	HSD3 Enable	0	Off	b2
		1	On	b2
HSD2EN	HSD2 Enable	0	Off	b1
		1	On	b1
HSD1EN	HSD1 Enable	0	Off	b0
		1	On	b0

Table 8. Data byte 1 description

Name	Description	State	Definition	bit
REG6 EN	REG6 Enable	0	Off	b6
		1	On	
REG5 EN	REG5 Enable	0	Off	b5
		1	On	
REG4 EN	REG4 Enable	0	Off	b4
		1	On	
REG2 EN	REG2 Enable	0	Off	b2
		1	On	
REG1 EN	REG1 Enable	0	Off	b1
		1	On	

4 Package information

In order to meet environmental requirements, ST offers these devices in ECOPACK® packages. These packages have a lead-free second level interconnect. the category of second level interconnect is marked on the package and on the inner box label, in compliance with JEDEC Standard JESD97. The maximum ratings related to soldering conditions are also marked on the inner box label. ECOPACK is an ST trademark. ECOPACK specifications are available at: www.st.com.

Figure 9. Flexiwatt27 (vertical) mechanical data and package dimensions

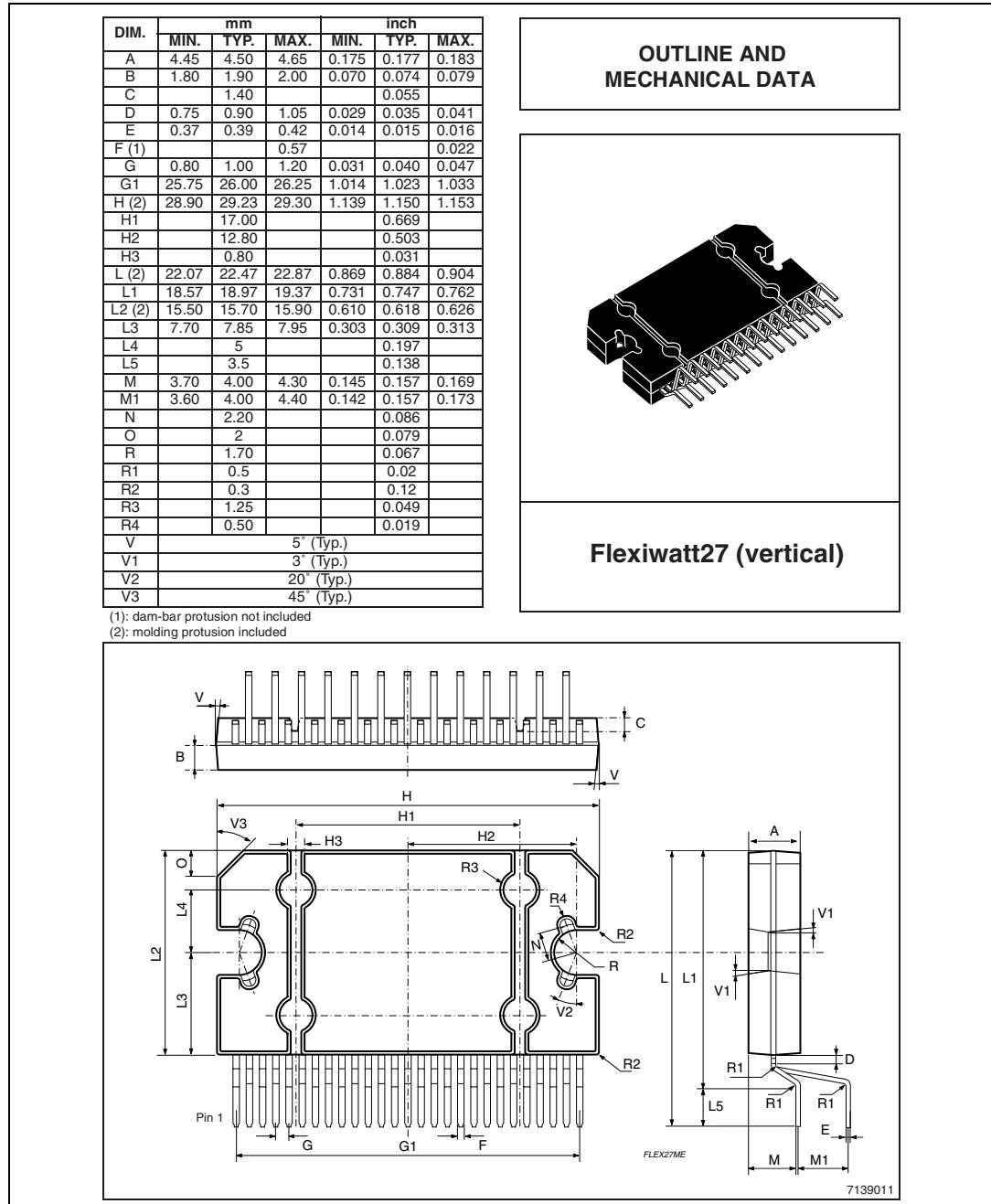

5 Revision history

Table 9. Document revision history

Date	Revision	Changes
29-Aug-2007	1	Initial release.

Please Read Carefully:

Information in this document is provided solely in connection with ST products. STMicroelectronics NV and its subsidiaries ("ST") reserve the right to make changes, corrections, modifications or improvements, to this document, and the products and services described herein at any time, without notice.

All ST products are sold pursuant to ST's terms and conditions of sale.

Purchasers are solely responsible for the choice, selection and use of the ST products and services described herein, and ST assumes no liability whatsoever relating to the choice, selection or use of the ST products and services described herein.

No license, express or implied, by estoppel or otherwise, to any intellectual property rights is granted under this document. If any part of this document refers to any third party products or services it shall not be deemed a license grant by ST for the use of such third party products or services, or any intellectual property contained therein or considered as a warranty covering the use in any manner whatsoever of such third party products or services or any intellectual property contained therein.

UNLESS OTHERWISE SET FORTH IN ST'S TERMS AND CONDITIONS OF SALE ST DISCLAIMS ANY EXPRESS OR IMPLIED WARRANTY WITH RESPECT TO THE USE AND/OR SALE OF ST PRODUCTS INCLUDING WITHOUT LIMITATION IMPLIED WARRANTIES OF MERCHANTABILITY, FITNESS FOR A PARTICULAR PURPOSE (AND THEIR EQUIVALENTS UNDER THE LAWS OF ANY JURISDICTION), OR INFRINGEMENT OF ANY PATENT, COPYRIGHT OR OTHER INTELLECTUAL PROPERTY RIGHT.

UNLESS EXPRESSLY APPROVED IN WRITING BY AN AUTHORIZED ST REPRESENTATIVE, ST PRODUCTS ARE NOT RECOMMENDED, AUTHORIZED OR WARRANTED FOR USE IN MILITARY, AIR CRAFT, SPACE, LIFE SAVING, OR LIFE SUSTAINING APPLICATIONS, NOR IN PRODUCTS OR SYSTEMS WHERE FAILURE OR MALFUNCTION MAY RESULT IN PERSONAL INJURY, DEATH, OR SEVERE PROPERTY OR ENVIRONMENTAL DAMAGE. ST PRODUCTS WHICH ARE NOT SPECIFIED AS "AUTOMOTIVE GRADE" MAY ONLY BE USED IN AUTOMOTIVE APPLICATIONS AT USER'S OWN RISK.

Resale of ST products with provisions different from the statements and/or technical features set forth in this document shall immediately void any warranty granted by ST for the ST product or service described herein and shall not create or extend in any manner whatsoever, any liability of ST.

ST and the ST logo are trademarks or registered trademarks of ST in various countries.

Information in this document supersedes and replaces all information previously supplied.

The ST logo is a registered trademark of STMicroelectronics. All other names are the property of their respective owners.

© 2007 STMicroelectronics - All rights reserved

STMicroelectronics group of companies

Australia - Belgium - Brazil - Canada - China - Czech Republic - Finland - France - Germany - Hong Kong - India - Israel - Italy - Japan - Malaysia - Malta - Morocco - Singapore - Spain - Sweden - Switzerland - United Kingdom - United States of America

www.st.com

