

Double channel high side driver

Features

Type	$R_{DS(on)}$	I_{OUT}	V_{CC}
VND830AEP-E	60m Ω ⁽¹⁾	6A ⁽¹⁾	36V

1. Per each channel.

- DC short circuit current: 6A
- CMOS compatible inputs
- Proportional load current sense
- Undervoltage and overvoltage shutdown
- Overvoltage clamp
- Thermal shutdown
- Current limitation
- Very low standby power dissipation
- Protection against loss of ground and loss of V_{CC}
- Reverse battery protection^(a)
- In compliance with the 2002/95/EC european directive



Description

The VND830AEP-E is a monolithic device made using STMicroelectronics VIPower™ M0-3 Technology. The VND830AEP-E is intended for driving any type of multiple load with one side connected to ground.

The Active V_{CC} pin voltage clamp protects the device against low energy spikes (see ISO7637 transient compatibility table).

This device has two channels in high side configuration; each channel has an analog sense output on which the sensing current is proportional (according to a known ratio) to the corresponding load current. Built-in thermal shutdown and outputs current limitation protect the chip from over temperature and short circuit. The device automatically turns off in the case where the ground pin becomes disconnected.

a. See [Application schematic on page 16](#)

Table 1. Device summary

Package	Order codes	
	Tube	Tape and reel
PowerSSO-24	VND830AEP-E	VND830AEPTR-E

Contents

1	Block diagram and pin description	5
2	Electrical specifications	6
2.1	Absolute maximum ratings	6
2.2	Thermal data	6
2.3	Electrical characteristics	7
2.4	Electrical characteristics curves	14
3	Application information	16
3.1	GND protection network against reverse battery	16
3.1.1	Solution 1: a resistor in the ground line (RGND only)	16
3.1.2	Solution 2: a diode (D_{GND}) in the ground line	17
3.2	Load dump protection	17
3.3	MCU I/O protection	17
3.4	Maximum demagnetization energy ($V_{CC} = 13.5V$)	18
4	Package and PC board thermal data	19
4.1	PowerSSO-24 thermal data	19
5	Package and packing information	22
5.1	ECOPACK® packages	22
5.2	PowerSSO-24 mechanical data	22
5.3	Packing information	24
6	Revision history	25

List of tables

Table 1.	Device summary	1
Table 2.	Suggested connections for unused and not connected pins	5
Table 3.	Absolute maximum ratings	6
Table 4.	Thermal data (per island)	6
Table 5.	Power output.	7
Table 6.	Protections	8
Table 7.	V _{CC} - output diode	8
Table 8.	Switching (V _{CC} = 13V; T _j = 25°C)	8
Table 9.	Logic inputs.	8
Table 10.	Current sense	9
Table 11.	Truth table.	11
Table 12.	Electrical transient requirements (part 1/3).	12
Table 13.	Electrical transient requirements (part 2/3).	12
Table 14.	Electrical transient requirements (part 3/3).	12
Table 15.	Thermal parameters	21
Table 16.	PowerSSO-24 mechanical data	23
Table 17.	Document revision history	25

List of figures

Figure 1.	Block diagram	5
Figure 2.	Configuration diagram (top view)	5
Figure 3.	Current and voltage conventions	7
Figure 4.	IOOUT/ISENSE versus IOOUT	10
Figure 5.	Switching characteristics	11
Figure 6.	Waveforms	13
Figure 7.	Off-state output current.	14
Figure 8.	High level input current.	14
Figure 9.	Input clamp voltage.	14
Figure 10.	Turn-on voltage slope.	14
Figure 11.	Overshoot shutdown	14
Figure 12.	Turn-off voltage slope.	14
Figure 13.	ILIM vs Tcase	15
Figure 14.	On-state resistance vs VCC	15
Figure 15.	Input high level	15
Figure 16.	Input hysteresis voltage	15
Figure 17.	On-state resistance vs Tcase	15
Figure 18.	Input low level.	15
Figure 19.	Application schematic.	16
Figure 20.	Maximum turn-off current versus load inductance	18
Figure 21.	PowerSSO-24 PC board.	19
Figure 22.	Rthj-amb vs PCB copper area in open box free air condition (one channel ON)	19
Figure 23.	PowerSSO-24 thermal impedance junction ambient single pulse (one channel ON).	20
Figure 24.	Thermal fitting model of a double channel HSD in PowerSSO-24	20
Figure 25.	PowerSSO-24 package dimensions	22
Figure 26.	PowerSSO-24 tube shipment (no suffix)	24
Figure 27.	PowerSSO-24 tape and reel shipment (suffix "TR")	24

1 Block diagram and pin description

Figure 1. Block diagram

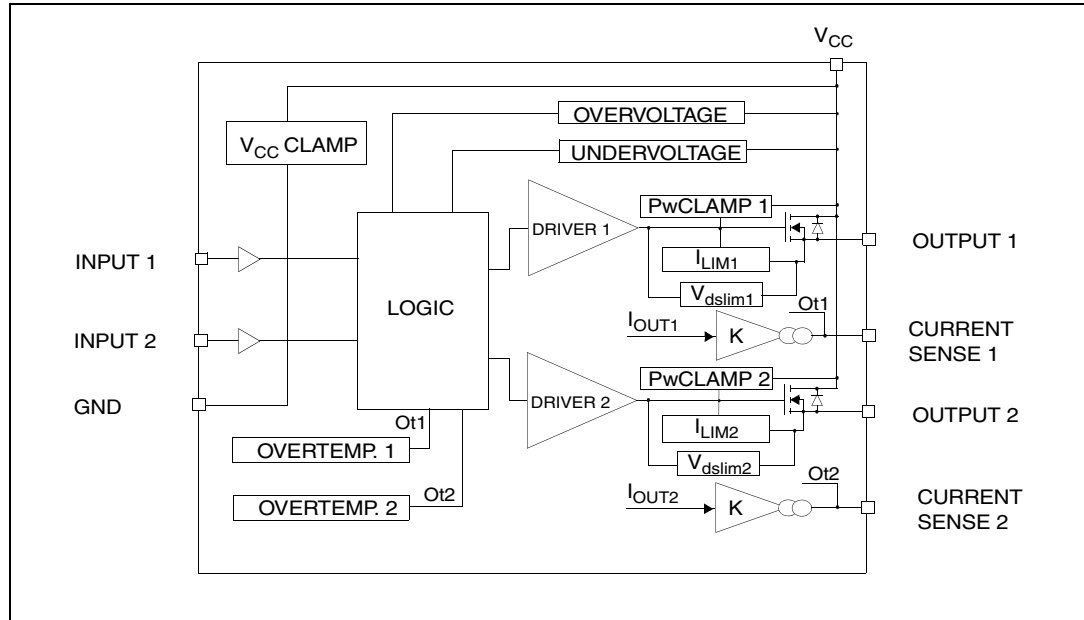

Figure 2. Configuration diagram (top view)

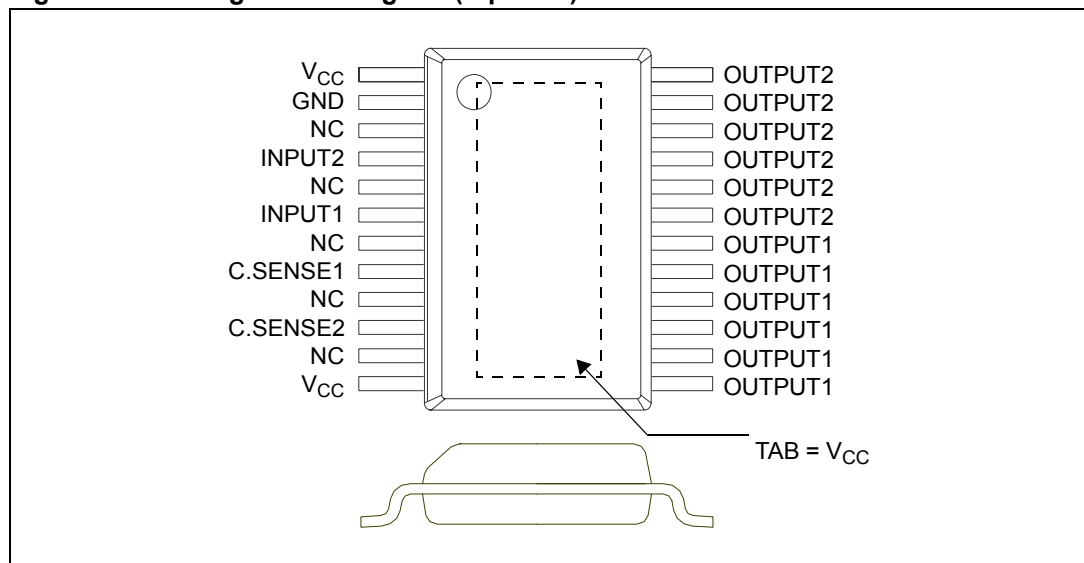

Table 2. Suggested connections for unused and not connected pins

Connection / pin	Current sense	N.C.	Output	Input
Floating		X	X	X
To ground	Through 1KΩ resistor	X		Through 10KΩ resistor

2 Electrical specifications

2.1 Absolute maximum ratings

Stressing the device above the rating listed in the “Absolute maximum ratings” table may cause permanent damage to the device. These are stress ratings only and operation of the device at these or any other conditions above those indicated in the Operating sections of this specification is not implied. Exposure to Absolute Maximum Rating conditions for extended periods may affect device reliability. Refer also to the STMicroelectronics SURE Program and other relevant quality document.

Table 3. Absolute maximum ratings

Symbol	Parameter	Value	Unit
V_{CC}	DC supply voltage	41	V
$-V_{CC}$	Reverse DC supply voltage	- 0.3	V
$-I_{GND}$	DC reverse ground pin current	- 200	mA
I_{OUT}	DC output current	Internally limited	A
I_R	Reverse DC output current	- 6	A
I_{IN}	DC input current	+/- 10	mA
V_{CSENSE}	Current sense maximum voltage	- 3	V
		15	V
V_{ESD}	Electrostatic discharge (human body model:R=1.5K Ω ; C=100pF)		
	– Input	4000	V
	– Current sense	2000	V
	– Output	5000	V
	– V_{CC}	5000	V
E_{MAX}	Maximum switching energy (L = 2.2mH; $R_L = 0\Omega$; $V_{bat} = 13.5V$; $T_{jstart} = 150^\circ C$; $I_L = 10A$)	153	mJ
P_{tot}	Power dissipation (per island) at $T_{lead} = 25^\circ C$	8.3	W
T_j	Junction operating temperature	Internally limited	$^\circ C$
T_c	Case operating temperature	- 40 to 150	$^\circ C$
T_{stg}	Storage temperature	- 55 to 150	$^\circ C$

2.2 Thermal data

Table 4. Thermal data (per island)

Symbol	Parameter	Max. value	Unit
$R_{thj-case}$	Thermal resistance junction-case	1.7	$^\circ C/W$
$R_{thj-amb}$	Thermal resistance junction-ambient (one chip ON)	55 ⁽¹⁾	$^\circ C/W$

- When mounted on a standard single-sided FR-4 board with 0.5cm² of Cu (at least 35 μm thick) connected to all Vcc pins. Horizontal mounting and no artificial air flow.

2.3 Electrical characteristics

Values specified in this section are for $8V < V_{CC} < 36V$; $-40^{\circ}C < T_j < 150^{\circ}C$, unless otherwise stated.

Figure 3. Current and voltage conventions

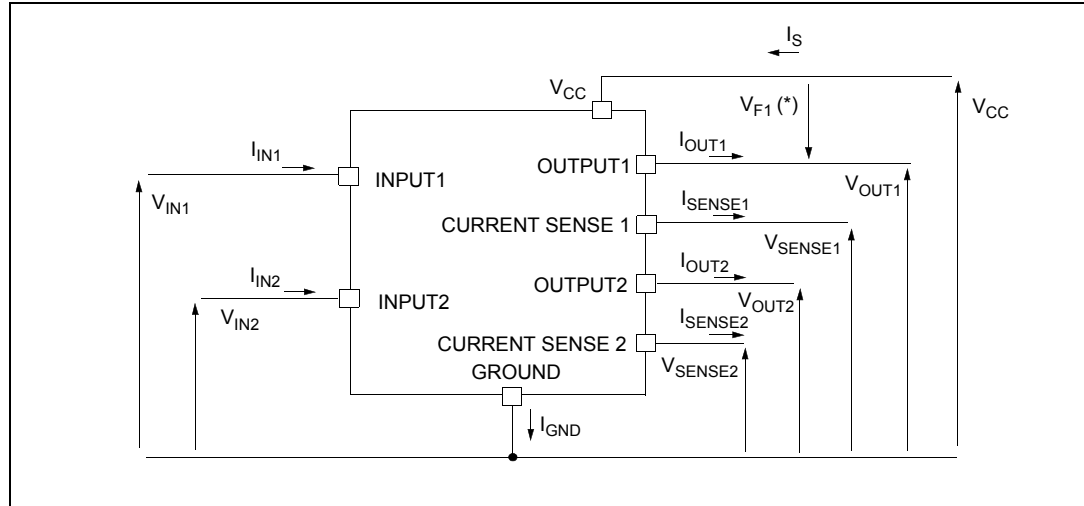

Note: $V_{Fn} = V_{CCn} - V_{OUTn}$ during reverse battery condition.

Table 5. Power output

Symbol	Parameter	Test conditions	Min.	Typ.	Max.	Unit
V_{CC}	Operating supply voltage		5.5	13	36	V
V_{USD}	Undervoltage shutdown		3	4	5.5	V
V_{OV}	Overvoltage shutdown		36			V
R_{ON}	On-state resistance	$I_{OUT} = 2A$; $T_j = 25^{\circ}C$ $I_{OUT} = 2A$; $T_j = 125^{\circ}C$			60 120	mΩ mΩ
V_{CLAMP}	Clamp voltage	$I_{CC} = 20mA$	41	48	55	V
I_S	Supply current	Off-state; $V_{CC} = 13V$; $V_{IN} = V_{OUT} = 0V$		12	40	μA
		Off-state; $V_{CC} = 13V$; $V_{IN} = V_{OUT} = 0V$; $T_j = 25^{\circ}C$		12	25	μA
		On-state; $V_{CC} = 13V$; $V_{IN} = 5V$; $I_{OUT} = 0A$; $R_{SENSE} = 3.9K\Omega$				7
$I_{L(off1)}$	Off-state output current	$V_{IN} = V_{OUT} = 0V$; $V_{CC} = 36V$; $T_j = 125^{\circ}C$	0		50	μA
$I_{L(off3)}$	Off-state output current	$V_{IN} = V_{OUT} = 0V$; $V_{CC} = 13V$; $T_j = 125^{\circ}C$			5	μA
$I_{L(off4)}$	Off-state output current	$V_{IN} = V_{OUT} = 0V$; $V_{CC} = 13V$; $T_j = 25^{\circ}C$			3	μA

Table 6. Protections

Symbol	Parameter	Test conditions	Min.	Typ.	Max.	Unit
I_{lim}	Current limitation	$V_{CC} = 13V$ $5.5V < V_{CC} < 36V$	6	10	15 15	A A
T_{TSD}	Shutdown temperature		150	175	200	°C
T_R	Reset temperature		135			°C
T_{hyst}	Thermal hysteresis		7	15		°C
V_{demag}	Turn-off output clamp voltage	$I_{OUT} = 2A$; $V_{IN} = 0V$; $L = 6mH$	$V_{CC} - 41$	$V_{CC} - 48$	$V_{CC} - 55$	V
V_{ON}	Output voltage drop limitation	$I_{OUT} = 10mA$		50		mV

Note: To ensure long term reliability under heavy overload or short circuit conditions, protection and related diagnostic signals must be used together with a proper software strategy. If the device is subjected to abnormal conditions, this software must limit the duration and number of activation cycles.

Table 7. V_{CC} - output diode

Symbol	Parameter	Test conditions	Min.	Typ.	Max.	Unit
V_F	Forward on voltage	$-I_{OUT} = 1.3A$; $T_j = 150^\circ C$			0.6	V

Table 8. Switching ($V_{CC} = 13V$; $T_j = 25^\circ C$)

Symbol	Parameter	Test conditions	Min.	Typ.	Max.	Unit
$t_{d(on)}$	Turn-on delay time	$R_L = 6.5\Omega$ from V_{IN} rising edge to $V_{OUT} = 1.3V$ (see Figure 5)		30		μs
$t_{d(off)}$	Turn-off delay time	$R_L = 6.5\Omega$ from V_{IN} falling edge to $V_{OUT} = 11.7V$ (see Figure 5)		30		μs
$dV_{OUT}/dt_{(on)}$	Turn-on voltage slope	$R_L = 6.5\Omega$ from $V_{OUT} = 1.3V$ to $V_{OUT} = 10.4V$ (see Figure 5)		See Figure 10		$V/\mu s$
$dV_{OUT}/dt_{(off)}$	Turn-off voltage slope	$R_L = 6.5\Omega$ from $V_{OUT} = 11.7V$ to $V_{OUT} = 1.3V$ (see Figure 5)		See Figure 12		$V/\mu s$

Table 9. Logic inputs

Symbol	Parameter	Test conditions	Min.	Typ.	Max.	Unit
V_{IL}	Input low level				1.25	V
I_{IL}	Low level input current	$V_{IN} = 1.25V$	1			μA
V_{IH}	Input high level		3.25			V
I_{IH}	High level input current	$V_{IN} = 3.25V$			10	μA

Table 9. Logic inputs (continued)

Symbol	Parameter	Test conditions	Min.	Typ.	Max.	Unit
$V_{I(hyst)}$	Input hysteresis voltage		0.5			V
V_{ICL}	Input clamp voltage	$I_{IN} = 1\text{mA}$ $I_{IN} = -1\text{mA}$	6	6.8 - 0.7	8	V V

Table 10. Current sense

Symbol	Parameter	Test conditions	Min.	Typ.	Max.	Unit
K_0	I_{OUT}/I_{SENSE}	I_{OUT1} or $I_{OUT2} = 0.05\text{A}$; $V_{SENSE} = 0.5\text{V}$; other channels open; $T_j = -40^\circ\text{C}...150^\circ\text{C}$	600	1300	2000	
K_1	I_{OUT}/I_{SENSE}	I_{OUT1} or $I_{OUT2} = 0.25\text{A}$; $V_{SENSE} = 0.5\text{V}$; other channels open; $T_j = -40^\circ\text{C}...150^\circ\text{C}$	1000	1400	1900	
dK_1/K_1	Current sense ratio drift	I_{OUT1} or $I_{OUT2} = 0.25\text{A}$; $V_{SENSE} = 0.5\text{V}$; other channels open; $T_j = -40^\circ\text{C}...150^\circ\text{C}$	-10		+10	%
K_2	I_{OUT}/I_{SENSE}	I_{OUT1} or $I_{OUT2} = 1.6\text{A}$; $V_{SENSE} = 4\text{V}$; other channels open; $T_j = -40^\circ\text{C}$ $T_j = 25^\circ\text{C}...150^\circ\text{C}$	1280 1300	1500	1800	
dK_2/K_2	Current sense ratio drift	I_{OUT1} or $I_{OUT2} = 1.6\text{A}$; $V_{SENSE} = 4\text{V}$; other channels open; $T_j = -40^\circ\text{C}...150^\circ\text{C}$	-6		+6	%
K_3	I_{OUT}/I_{SENSE}	I_{OUT1} or $I_{OUT2} = 2.5\text{A}$; $V_{SENSE} = 4\text{V}$; other channels open; $T_j = -40^\circ\text{C}$ $T_j = 25^\circ\text{C}...150^\circ\text{C}$	1280 1340	1500	1680	
dK_3/K_3	Current sense ratio drift	I_{OUT1} or $I_{OUT2} = 2.5\text{A}$; $V_{SENSE} = 4\text{V}$; other channels open; $T_j = -40^\circ\text{C}...150^\circ\text{C}$	-6		+6	%
I_{SENSE}	Analog sense leakage current	$V_{IN} = 0\text{V}$; $I_{OUT} = 0\text{A}$; $V_{SENSE} = 0\text{V}$; $T_j = -40^\circ\text{C}...150^\circ\text{C}$ $V_{IN} = 5\text{V}$; $I_{OUT} = 0\text{A}$; $V_{SENSE} = 0\text{V}$; $T_j = -40^\circ\text{C}...150^\circ\text{C}$	0		5	μA
V_{SENSE}	Max. analog sense output voltage	$V_{CC} = 5.5\text{V}$; $I_{OUT1,2} = 1.3\text{A}$; $R_{SENSE} = 10\text{k}\Omega$ $V_{CC} > 8\text{V}$; $I_{OUT1,2} = 2.5\text{A}$; $R_{SENSE} = 10\text{k}\Omega$	2			V
V_{SENSEH}	Sense voltage in over temperature conditions	$V_{CC} = 13\text{V}$; $R_{SENSE} = 3.9\text{k}\Omega$		5.5		V

Table 10. Current sense (continued)

Symbol	Parameter	Test conditions	Min.	Typ.	Max.	Unit
$R_{VSENSEH}$	Analog sense output impedance in over temperature condition	$V_{CC} = 13V; T_j > T_{TSD};$ All channels open		400		Ω
t_{DSENSE}	Current sense delay response	To 90% $I_{SENSE}^{(1)}$			500	μs

1. Current sense signal delay after positive input slope.

Figure 4. I_{OUT}/I_{SENSE} versus I_{OUT}

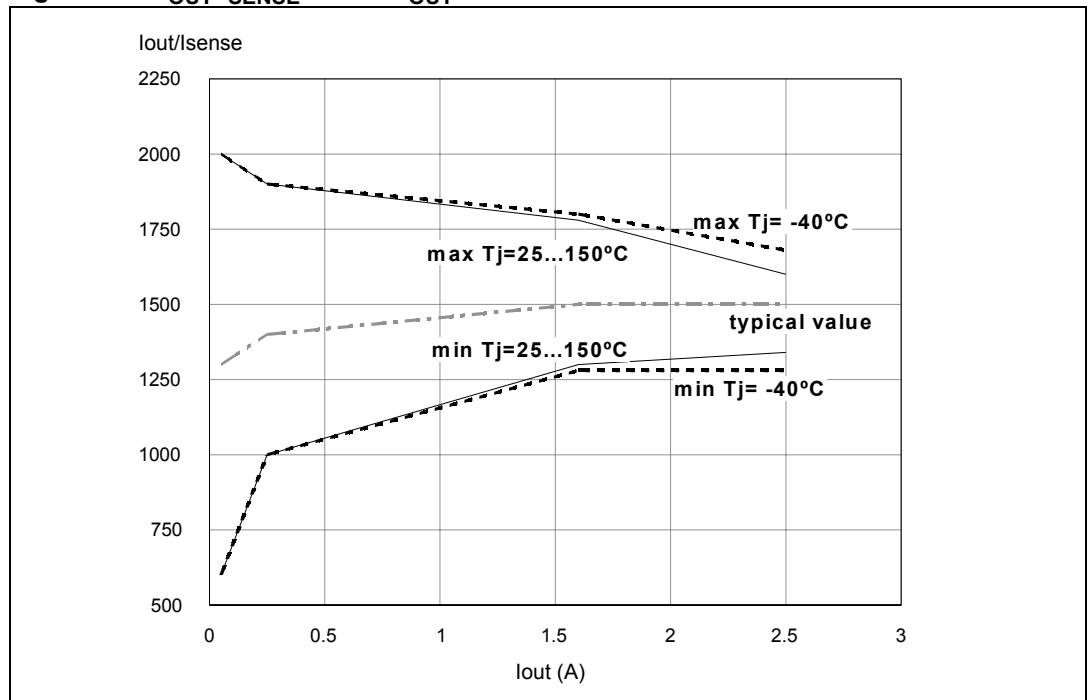

Figure 5. Switching characteristics

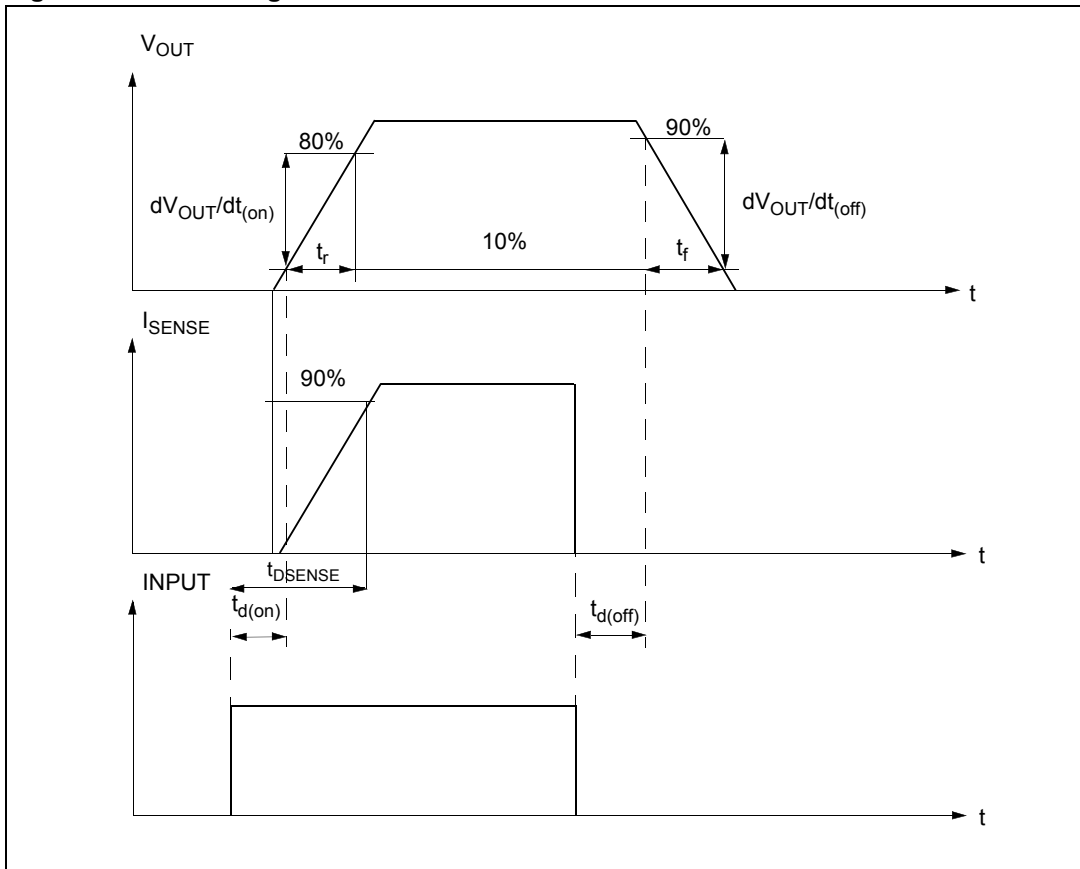

Table 11. Truth table

Conditions	Input	Output	Sense
Normal operation	L	L	0
	H	H	Nominal
Overtemperature	L	L	0
	H	L	V_{SENSEH}
Undervoltage	L	L	0
	H	L	0
Overvoltage	L	L	0
	H	L	0
Short circuit to GND	L	L	0
	H	L	$(T_J < T_{TSD})$ 0 $(T_J > T_{TSD})$ 0
Short circuit to V_{CC}	L	H	0
	H	H	< Nominal
Negative output voltage clamp	L	L	0

Table 12. Electrical transient requirements (part 1/3)

ISO T/R 7637/1 Test pulse	Test level				Delays and impedance
	I	II	III	IV	
1	- 25V	- 50V	- 75V	- 100V	2ms, 10Ω
2	+ 25V	+ 50V	+ 75V	+ 100V	0.2ms, 10Ω
3a	- 25V	- 50V	- 100V	- 150V	0.1μs, 50Ω
3b	+ 25V	+ 50V	+ 75V	+ 100V	0.1μs, 50Ω
4	- 4V	- 5V	- 6V	- 7V	100ms, 0.01Ω
5	+ 26.5V	+ 46.5V	+ 66.5V	+ 86.5V	400ms, 2Ω

Table 13. Electrical transient requirements (part 2/3)

ISO T/R 7637/1 Test pulse	Test level			
	I	II	III	IV
1	C	C	C	C
2	C	C	C	C
3a	C	C	C	C
3b	C	C	C	C
4	C	C	C	C
5	C	E	E	E

Table 14. Electrical transient requirements (part 3/3)

Class	Contents
C	All functions of the device are performed as designed after exposure to disturbance.
E	One or more functions of the device is not performed as designed after exposure and cannot be returned to proper operation without replacing the device.

Figure 6. Waveforms

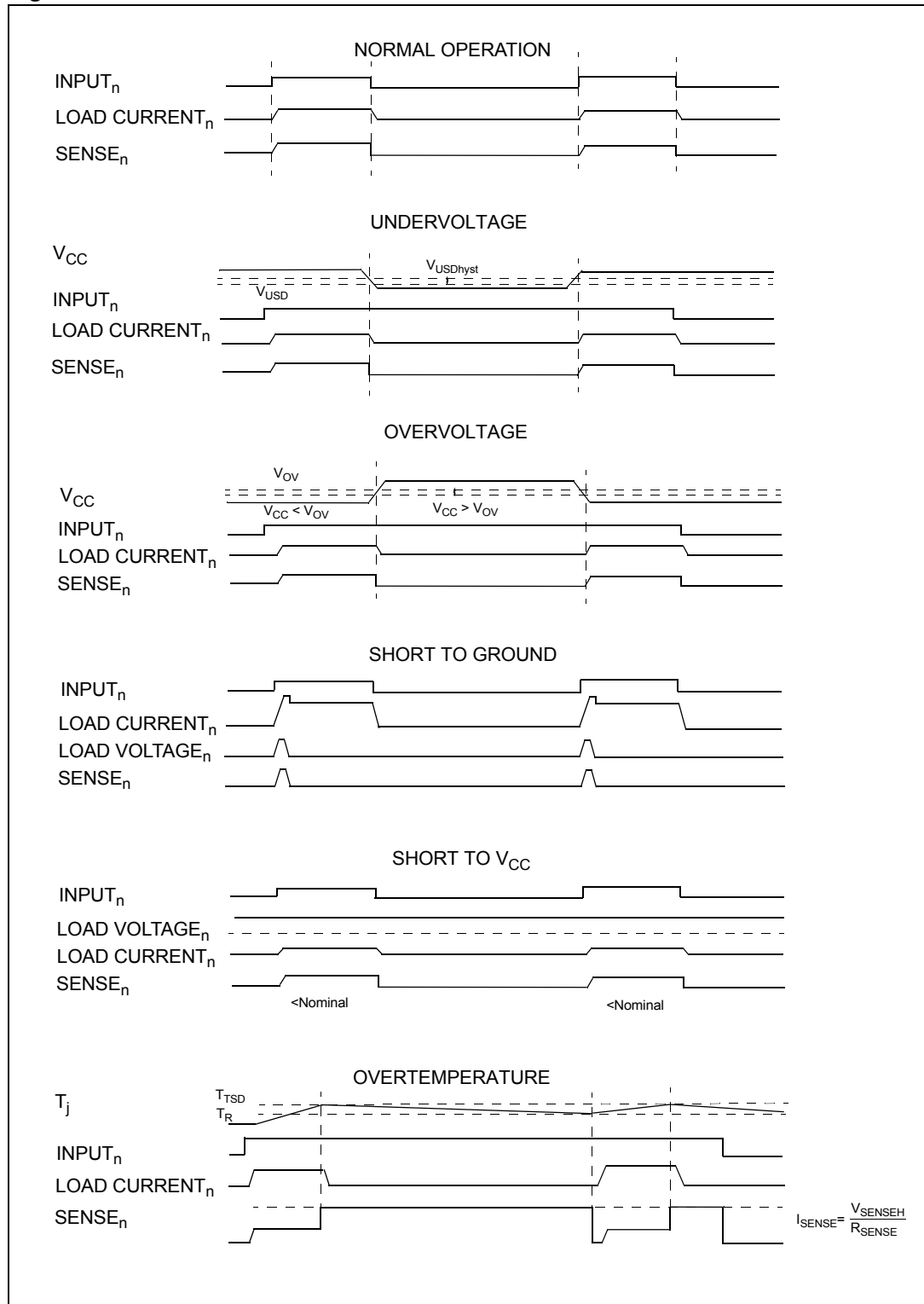

2.4 Electrical characteristics curves

Figure 7. Off-state output current

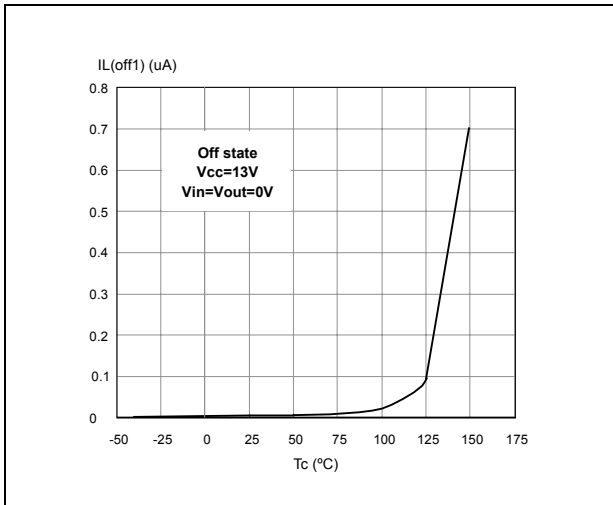

Figure 8. High level input current

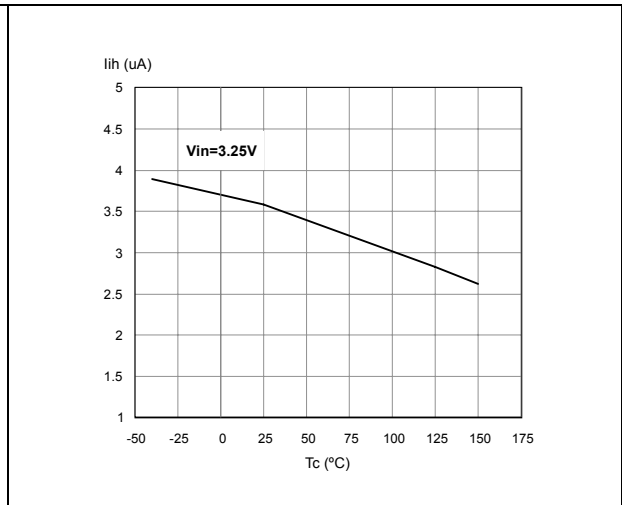

Figure 9. Input clamp voltage

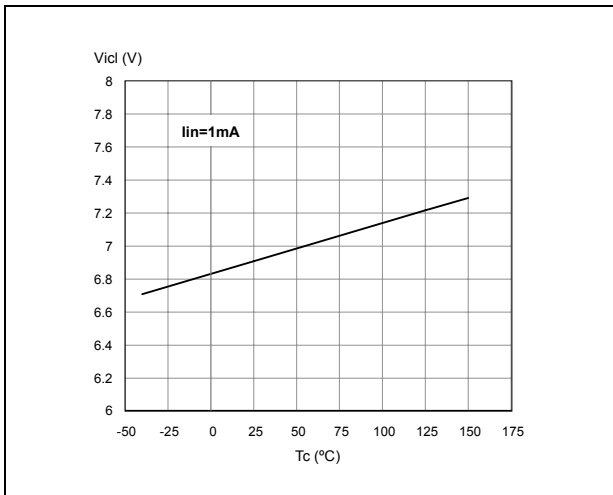

Figure 10. Turn-on voltage slope

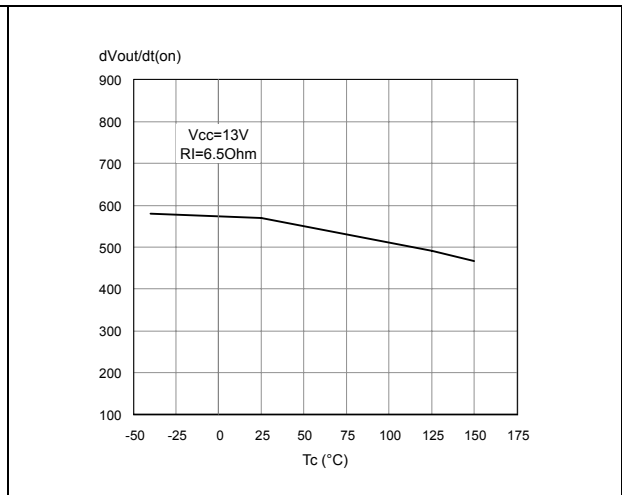

Figure 11. Overvoltage shutdown

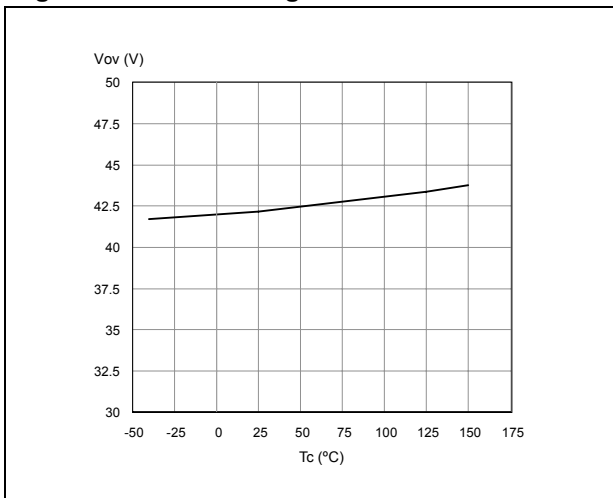

Figure 12. Turn-off voltage slope

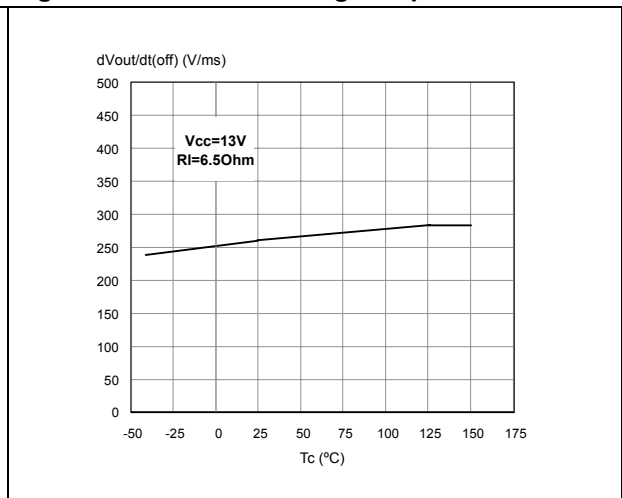

Figure 13. I_{LIM} vs T_{case}

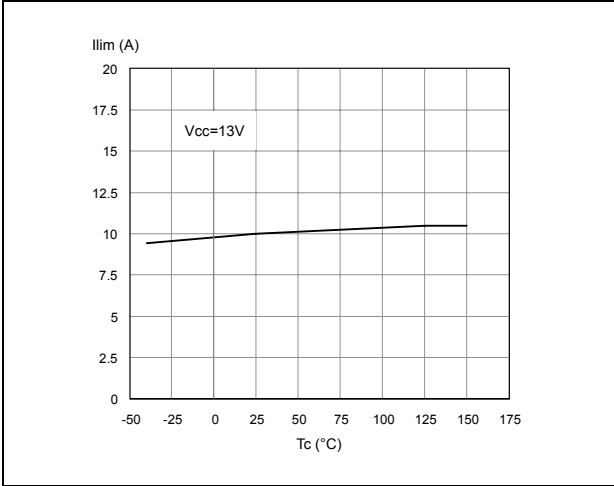

Figure 14. On-state resistance vs V_{CC}

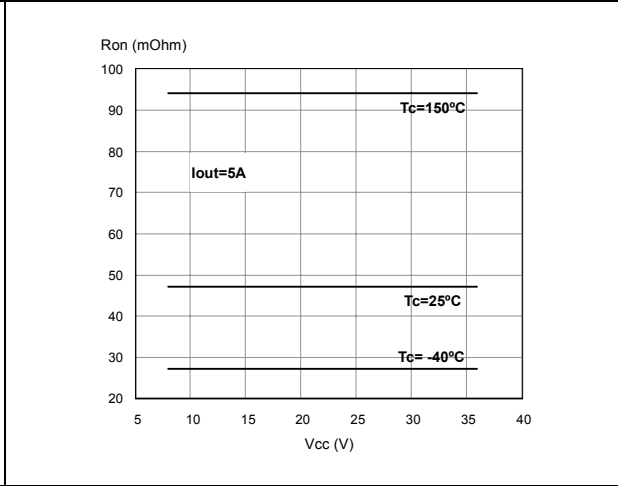

Figure 15. Input high level

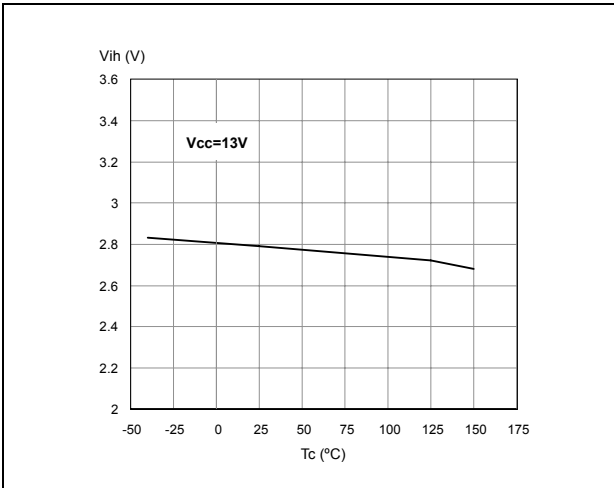

Figure 16. Input hysteresis voltage

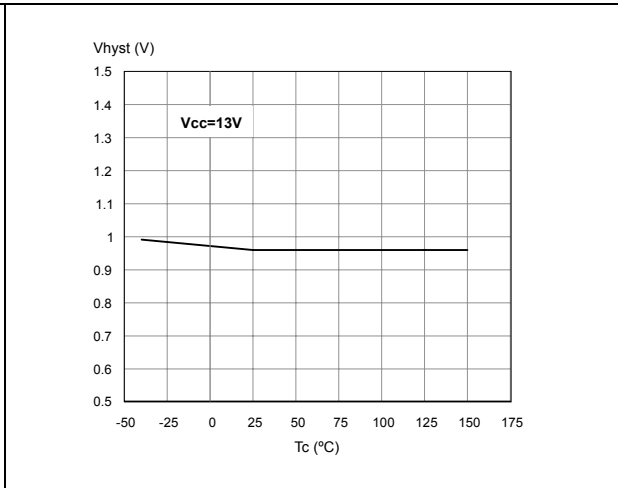

Figure 17. On-state resistance vs T_{case}

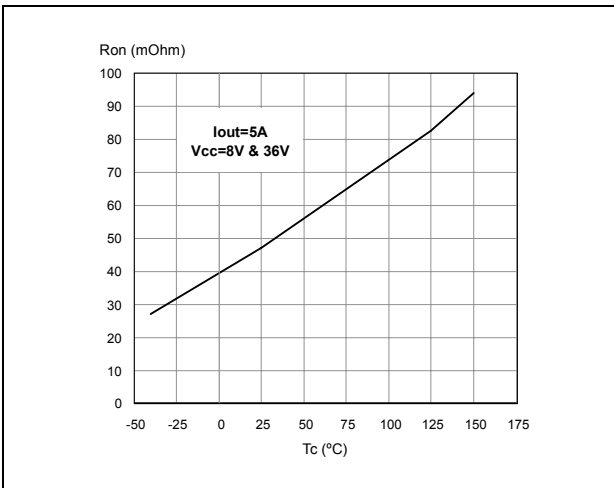
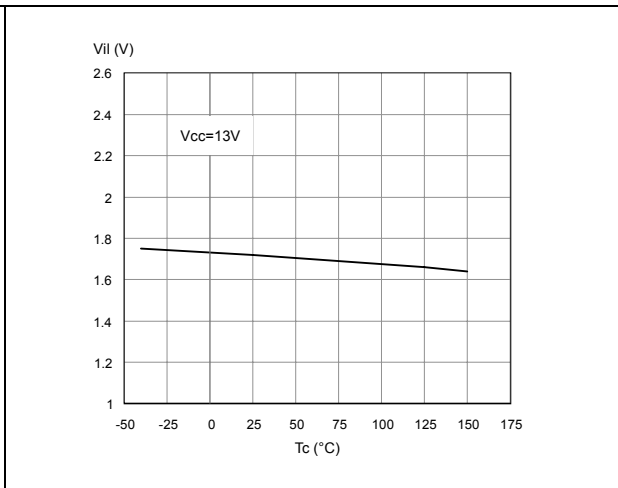
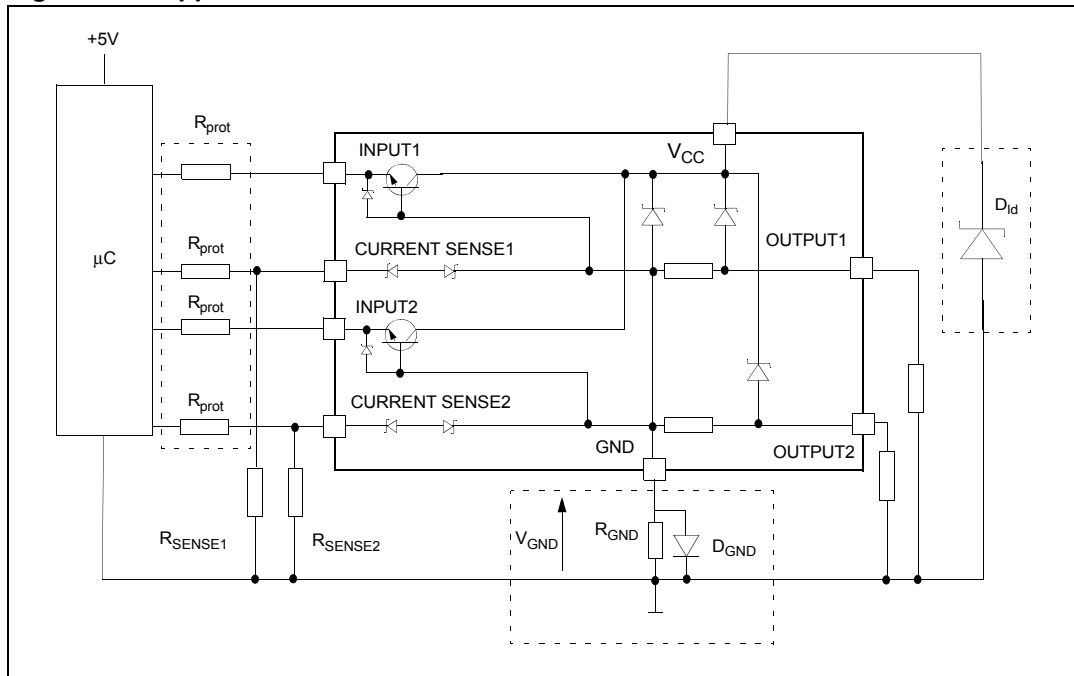

Figure 18. Input low level



3 Application information

Figure 19. Application schematic



3.1 GND protection network against reverse battery

This section provides two solutions for implementing a ground protection network against reverse battery.

3.1.1 Solution 1: a resistor in the ground line (R_{GND} only)

This can be used with any type of load.

The following show how to dimension the R_{GND} resistor:

1. $R_{GND} \leq 600\text{mV} / 2 (I_{S(on)max})$
2. $R_{GND} \geq (-V_{CC}) / (-I_{GND})$

where $-I_{GND}$ is the DC reverse ground pin current and can be found in the absolute maximum rating section of the device datasheet.

Power dissipation in R_{GND} (when $V_{CC} < 0$ during reverse battery situations) is:

$$P_D = (-V_{CC})^2 / R_{GND}$$

This resistor can be shared amongst several different HSDs. Please note that the value of this resistor should be calculated with formula (1) where $I_{S(on)max}$ becomes the sum of the maximum on-state currents of the different devices.

Please note that, if the microprocessor ground is not shared by the device ground, then the R_{GND} will produce a shift ($I_{S(on)max} * R_{GND}$) in the input thresholds and the status output values. This shift will vary depending on how many devices are ON in the case of several high side drivers sharing the same R_{GND}.

If the calculated power dissipation requires the use of a large resistor, or several devices have to share the same resistor, then ST suggests using solution 2 below.

3.1.2 Solution 2: a diode (D_{GND}) in the ground line

A resistor ($R_{GND} = 1k\Omega$) should be inserted in parallel to D_{GND} if the device will be driving an inductive load. This small signal diode can be safely shared amongst several different HSD. Also in this case, the presence of the ground network will produce a shift ($\pm 600mV$) in the input threshold and the status output values if the microprocessor ground is not common with the device ground. This shift will not vary if more than one HSD shares the same diode/resistor network. Series resistor in INPUT and STATUS lines are also required to prevent that, during battery voltage transient, the current exceeds the Absolute Maximum Rating. Safest configuration for unused INPUT and STATUS pin is to leave them unconnected.

3.2 Load dump protection

D_{ld} is necessary (voltage transient suppressor) if the load dump peak voltage exceeds the V_{CC} maximum DC rating. The same applies if the device is subject to transients on the V_{CC} line that are greater than those shown in the ISO T/R 7637/1 table.

3.3 MCU I/O protection

If a ground protection network is used and negative transients are present on the V_{CC} line, the control pins will be pulled negative. ST suggests to insert a resistor (R_{prot}) in line to prevent the μC I/O pins from latching up.

The value of these resistors is a compromise between the leakage current of μC and the current required by the HSD I/Os (Input levels compatibility) with the latch-up limit of μC I/Os:

$$-V_{CCpeak} / I_{latchup} \leq R_{prot} \leq (V_{OH\mu C} - V_{IH} - V_{GND}) / I_{IHmax}$$

Example

For the following conditions:

$$V_{CCpeak} = -100V$$

$$I_{latchup} \geq 20mA$$

$$V_{OH\mu C} \geq 4.5V$$

$$5k\Omega \leq R_{prot} \leq 65k\Omega$$

Recommended values are:

$$R_{prot} = 10k\Omega$$

3.4 Maximum demagnetization energy ($V_{CC} = 13.5V$)

Figure 20. Maximum turn-off current versus load inductance

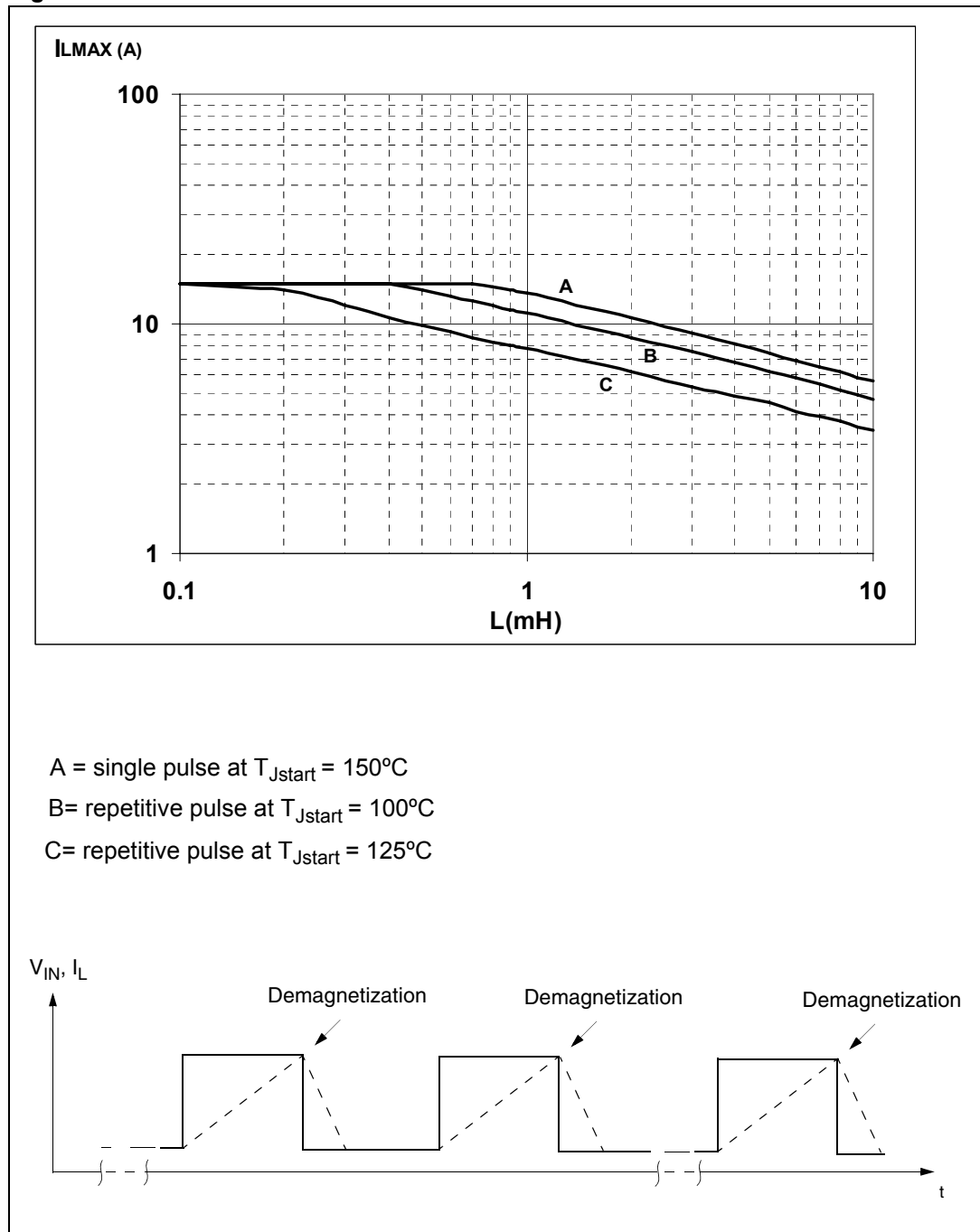

Note: Values are generated with $R_L = 0\Omega$.
 In case of repetitive pulses, T_{Jstart} (at beginning of each demagnetization) of every pulse must not exceed the temperature specified above for curves B and C.

4 Package and PC board thermal data

4.1 PowerSSO-24 thermal data

Figure 21. PowerSSO-24 PC board

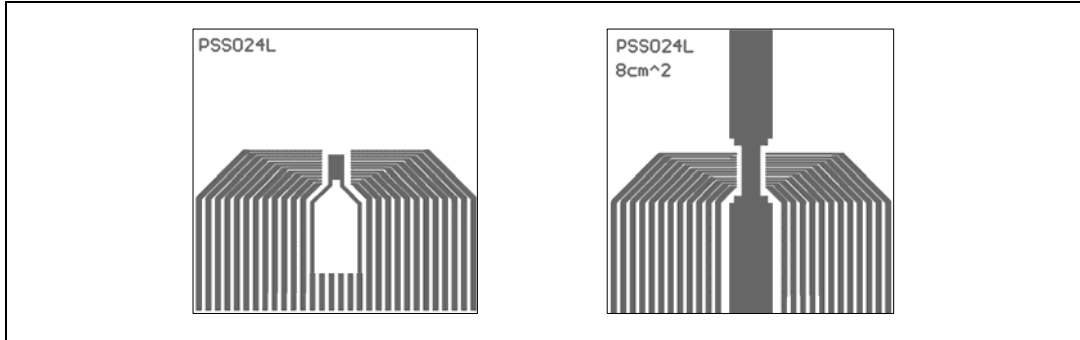

Note: Layout condition of R_{th} and Z_{th} measurements (PCB FR4 area= 78 mm x 78 mm, PCB thickness=2 mm, Cu thickness=70 mm (front and back side), Copper areas: from minimum pad lay-out to 8 cm²).

Figure 22. $R_{thj-amb}$ vs PCB copper area in open box free air condition (one channel ON)

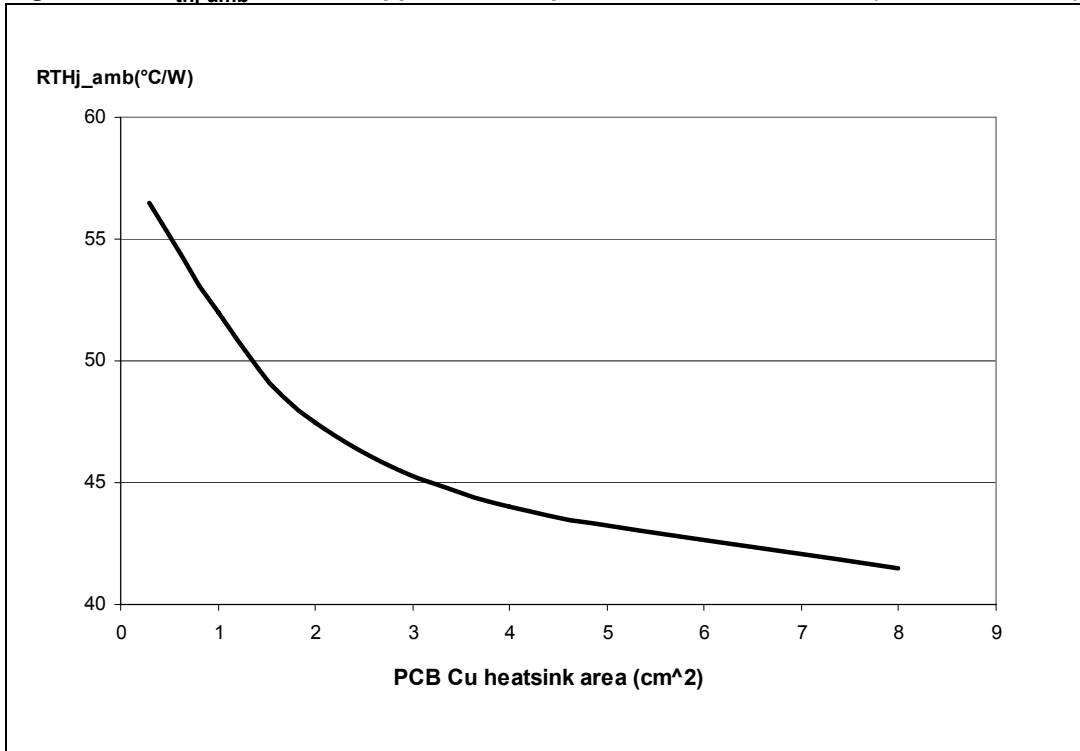

Figure 23. PowerSSO-24 thermal impedance junction ambient single pulse (one channel ON)

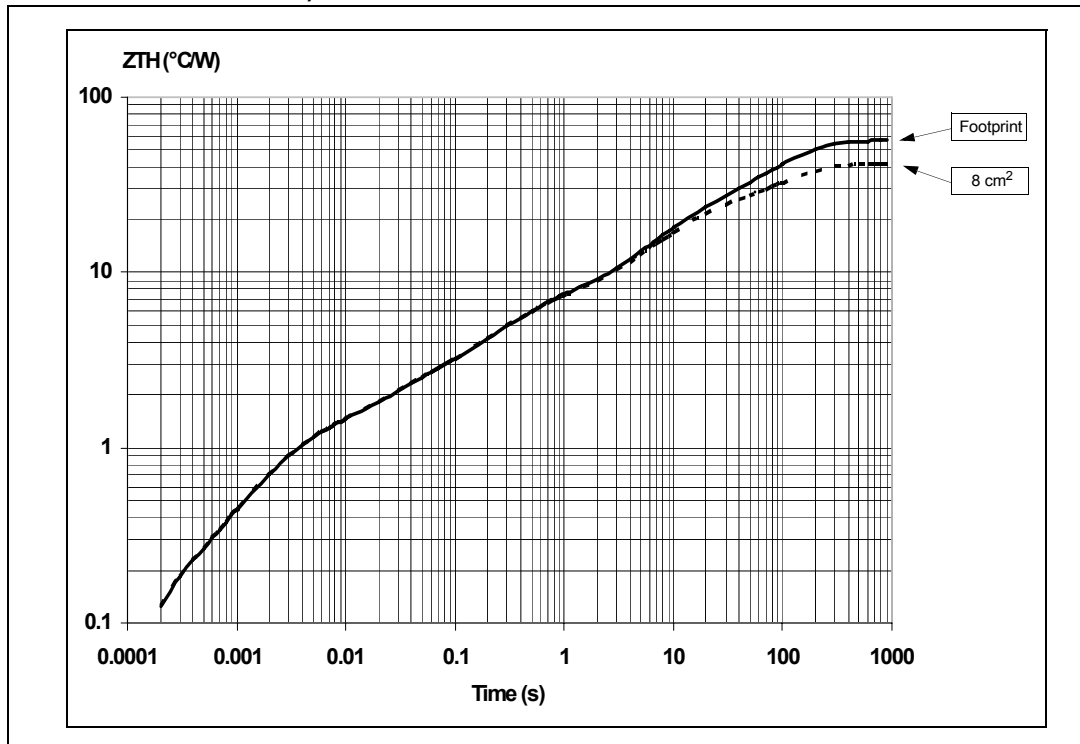
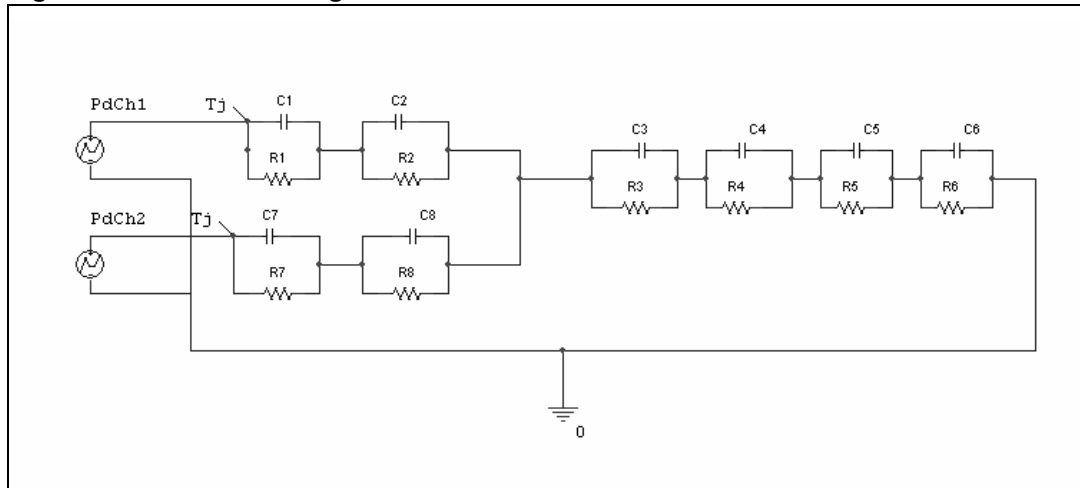

Figure 24. Thermal fitting model of a double channel HSD in PowerSSO-24 (b)



Equation 1: pulse calculation formula:

$$Z_{TH\delta} = R_{TH} \cdot \delta + Z_{THtp}(1 - \delta)$$

where $\delta = t_p/T$

- b. The fitting model is a simplified thermal tool and is valid for transient evolutions where the embedded protections (power limitation or thermal cycling during thermal shutdown) are not triggered.

Table 15. Thermal parameters

Area/island (cm ²)	Footprint	8
R1 = R7 (°C/W)	0.1	
R2 = R8 (°C/W)	0.9	
R3 (°C/W)	1	
R4 (°C/W)	4	
R5 (°C/W)	13.5	
R6 (°C/W)	37	22
C1 = C7 (W.s/°C)	0.0006	
C2 = C8 (W.s/°C)	0.0025	
C3 (W.s/°C)	0.025	
C4 (W.s/°C)	0.08	
C5 (W.s/°C)	0.7	
C6 (W.s/°C)	3	5

5 Package and packing information

5.1 ECOPACK[®] packages

In order to meet environmental requirements, ST offers these devices in different grades of ECOPACK[®] packages, depending on their level of environmental compliance. ECOPACK[®] specifications, grade definitions and product status are available at: www.st.com.

ECOPACK[®] is an ST trademark.

5.2 PowerSSO-24 mechanical data

Figure 25. PowerSSO-24 package dimensions

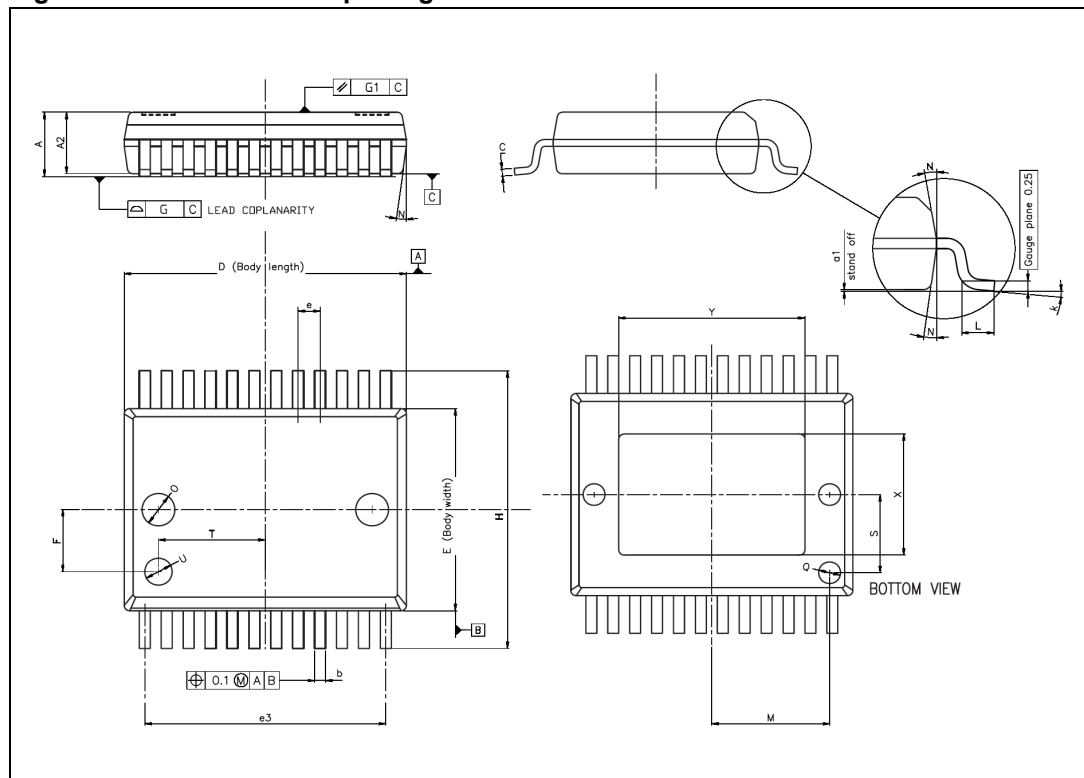

Table 16. PowerSSO-24 mechanical data^{(1) (2)}

Symbol	Millimeters		
	Min.	Typ.	Max.
A			2.45
A2	2.15		2.35
a1	0		0.10
b	0.33		0.51
c	0.23		0.32
D ⁽³⁾	10.10		10.50
E ⁽³⁾	7.40		7.60
e		0.8	
e3		8.8	
F		2.3	
G			0.1
G1			0.06
H	10.1		10.5
h			0.4
k	0°		8°
L	0.55		0.85
O		1.2	
Q		0.8	
S		2.9	
T		3.65	
U		1	
N			10°
X	4.1		4.7
Y	6.5 4.9 ⁽⁴⁾		7.1 5.5 ⁽⁴⁾

1. No intrusion allowed inwards the leads.
2. Flash or bleeds on exposed die pad shall not exceed 0.4 mm per side
3. "D and E" do not include mold flash or protusions. Mold flash or protusions shall not exceed 0.15 mm.
4. Variations for small window leadframe option.

5.3 Packing information

Figure 26. PowerSSO-24 tube shipment (no suffix)

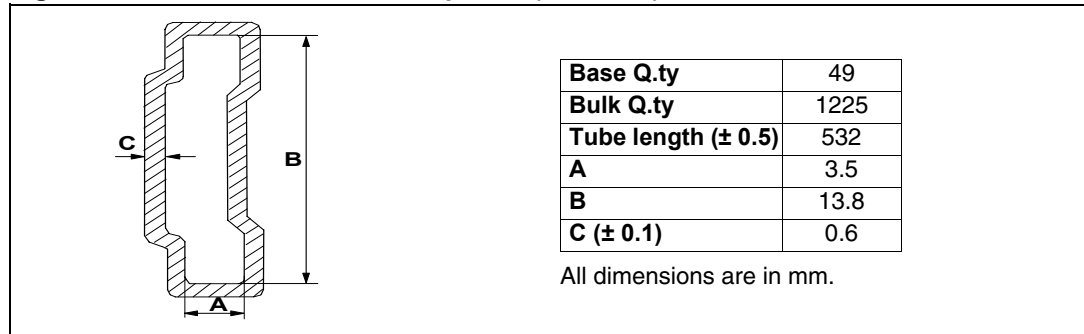
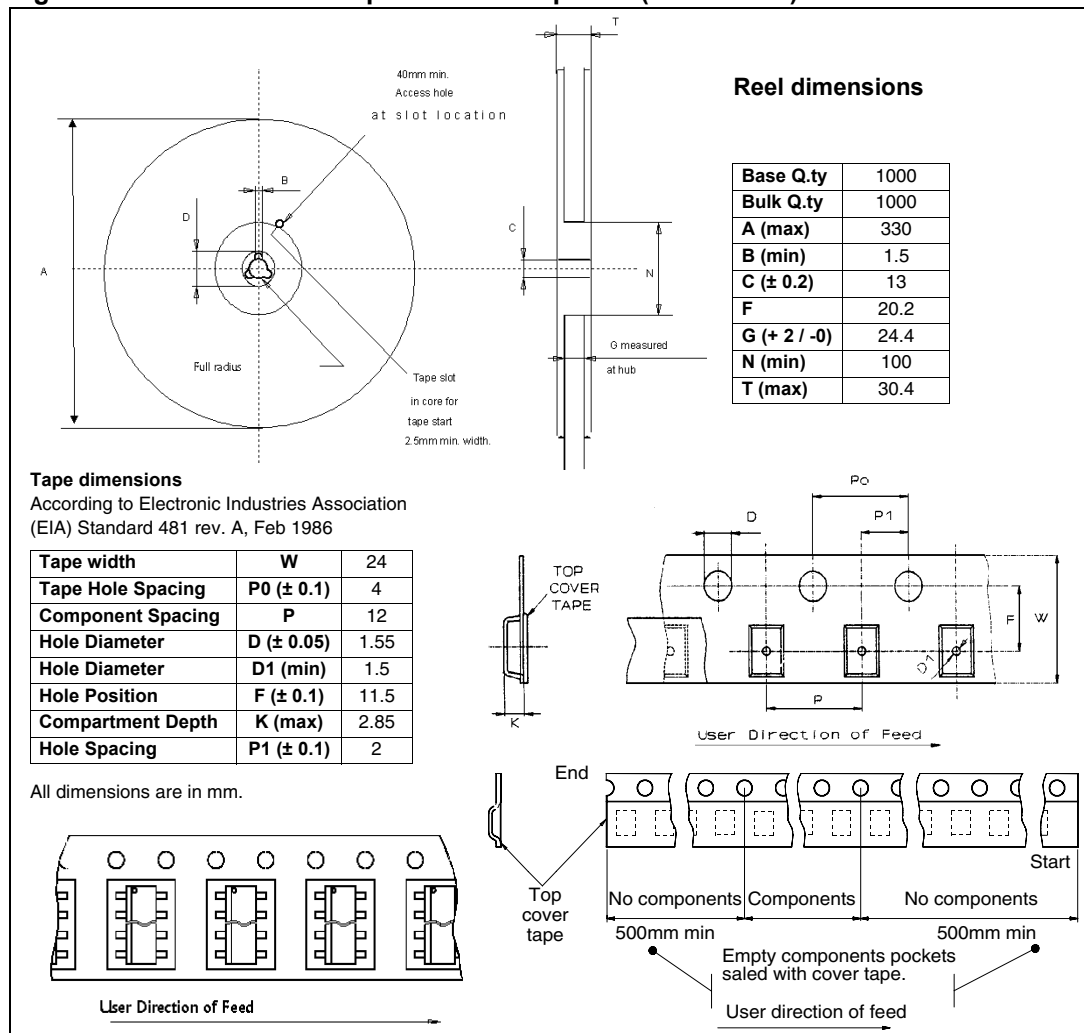

Figure 27. PowerSSO-24 tape and reel shipment (suffix "TR")



6 Revision history

Table 17. Document revision history

Date	Revision	Changes
04-Feb-2005	1	Initial release.
27-Nov-2008	2	Document reformatted and restructured. Added list of contents, tables and figures. Added <i>ECOPACK® packages</i> information. Update <i>PowerSSO-24 mechanical data</i> .
01-Jul-2009	3	Updated <i>Figure 16: PowerSSO-24 mechanical data</i> : <ul style="list-style-type: none">– Deleted A (min) value– Changed A (max) value from 2.50 to 2.45– Changed A2 (max) value from 2.40 to 2.35– Updated k values– Changed L (min) value from 0.6 to 0.55– Changed L (max) value from 1 to 0.85

Please Read Carefully:

Information in this document is provided solely in connection with ST products. STMicroelectronics NV and its subsidiaries ("ST") reserve the right to make changes, corrections, modifications or improvements, to this document, and the products and services described herein at any time, without notice.

All ST products are sold pursuant to ST's terms and conditions of sale.

Purchasers are solely responsible for the choice, selection and use of the ST products and services described herein, and ST assumes no liability whatsoever relating to the choice, selection or use of the ST products and services described herein.

No license, express or implied, by estoppel or otherwise, to any intellectual property rights is granted under this document. If any part of this document refers to any third party products or services it shall not be deemed a license grant by ST for the use of such third party products or services, or any intellectual property contained therein or considered as a warranty covering the use in any manner whatsoever of such third party products or services or any intellectual property contained therein.

UNLESS OTHERWISE SET FORTH IN ST'S TERMS AND CONDITIONS OF SALE ST DISCLAIMS ANY EXPRESS OR IMPLIED WARRANTY WITH RESPECT TO THE USE AND/OR SALE OF ST PRODUCTS INCLUDING WITHOUT LIMITATION IMPLIED WARRANTIES OF MERCHANTABILITY, FITNESS FOR A PARTICULAR PURPOSE (AND THEIR EQUIVALENTS UNDER THE LAWS OF ANY JURISDICTION), OR INFRINGEMENT OF ANY PATENT, COPYRIGHT OR OTHER INTELLECTUAL PROPERTY RIGHT.

UNLESS EXPRESSLY APPROVED IN WRITING BY AN AUTHORIZED ST REPRESENTATIVE, ST PRODUCTS ARE NOT RECOMMENDED, AUTHORIZED OR WARRANTED FOR USE IN MILITARY, AIR CRAFT, SPACE, LIFE SAVING, OR LIFE SUSTAINING APPLICATIONS, NOR IN PRODUCTS OR SYSTEMS WHERE FAILURE OR MALFUNCTION MAY RESULT IN PERSONAL INJURY, DEATH, OR SEVERE PROPERTY OR ENVIRONMENTAL DAMAGE. ST PRODUCTS WHICH ARE NOT SPECIFIED AS "AUTOMOTIVE GRADE" MAY ONLY BE USED IN AUTOMOTIVE APPLICATIONS AT USER'S OWN RISK.

Resale of ST products with provisions different from the statements and/or technical features set forth in this document shall immediately void any warranty granted by ST for the ST product or service described herein and shall not create or extend in any manner whatsoever, any liability of ST.

ST and the ST logo are trademarks or registered trademarks of ST in various countries.

Information in this document supersedes and replaces all information previously supplied.

The ST logo is a registered trademark of STMicroelectronics. All other names are the property of their respective owners.

© 2009 STMicroelectronics - All rights reserved

STMicroelectronics group of companies

Australia - Belgium - Brazil - Canada - China - Czech Republic - Finland - France - Germany - Hong Kong - India - Israel - Italy - Japan - Malaysia - Malta - Morocco - Philippines - Singapore - Spain - Sweden - Switzerland - United Kingdom - United States of America

www.st.com