

## Car alternator multifunction smart voltage regulator

Datasheet – production data

### Features

- Fully monolithic design
- High side field driver
- Thermal protection
- Field short circuit protection
- Protected diagnostic lamp driver
- Protected high side relay driver
- Complex diagnostics
- Load response control
- DFM output (field monitor)

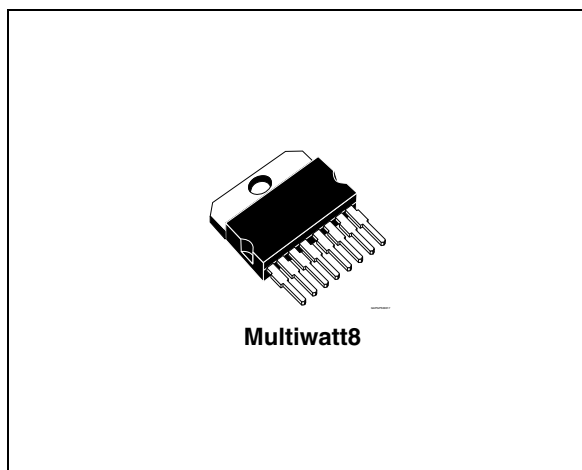

### Description

The L9911 is a monolithic multifunction alternator voltage regulator intended for use in automotive application.

It includes the control section, the field power stage, fault diagnostic circuit which drives a warning lamp, and the protection against short circuits.

**Table 1. Device summary**

Order code	Temp. range, °C	Package	Packing
L9911F	$T_j = -40$ to $+150$	Multiwatt8	Tube
L9911I			
L9911P			
L9911V			
L9911K			
L9911U			

# Contents

<b>1</b>	<b>Circuit operation</b> .....	<b>5</b>
	1.1 Voltage regulation .....	5
	1.2 Protection .....	5
	1.3 Diagnosis .....	5
	1.4 Load response control .....	5
<b>2</b>	<b>Pin description</b> .....	<b>6</b>
<b>3</b>	<b>Electrical specification</b> .....	<b>7</b>
	3.1 Absolute maximum ratings .....	7
	3.2 Thermal data .....	7
	3.3 Electrical characteristics .....	7
	3.4 Principle of phase regulation .....	14
<b>4</b>	<b>Package information</b> .....	<b>17</b>
<b>5</b>	<b>Revision history</b> .....	<b>18</b>

## List of tables

Table 1.	Device summary . . . . .	1
Table 2.	Pin description . . . . .	6
Table 3.	Absolute maximum ratings . . . . .	7
Table 4.	Thermal data . . . . .	7
Table 5.	Electrical characteristics . . . . .	7
Table 6.	Load response control parameters . . . . .	10
Table 7.	Load response control timing options . . . . .	10
Table 8.	Correspondence of frequency (typical values) to application features . . . . .	11
Table 9.	Customization of L9911: combination of LRC, regulation, and application options . . . . .	11
Table 10.	Fault detection . . . . .	16
Table 11.	Document revision history . . . . .	18

## List of figures

Figure 1.	Pin connection (top view) . . . . .	6
Figure 2.	$V_{reg-1}$ . . . . .	11
Figure 3.	$V_{reg-2}$ . . . . .	12
Figure 4.	$V_{reg-3}$ . . . . .	12
Figure 5.	$V_{reg-4}$ . . . . .	13
Figure 6.	Output voltage rise/fall time (F+, DFM) . . . . .	13
Figure 7.	Phase regulation characteristics . . . . .	13
Figure 8.	Application diagram . . . . .	14
Figure 9.	High side/low side driver saturation . . . . .	14
Figure 10.	Test mode to cancel soft-start/attack . . . . .	14
Figure 11.	Soft-start enable frequency range . . . . .	14
Figure 12.	Soft-start characteristics (always activated at engine start) . . . . .	15
Figure 13.	Soft start/attack characteristics . . . . .	15
Figure 14.	DF monitor electrical configuration . . . . .	16
Figure 15.	Short circuit drivers' protection . . . . .	16
Figure 16.	Multiwatt8 mechanical data and package dimensions . . . . .	17

# 1 Circuit operation

The alternator's voltage regulator performs the following main functions:

1. voltage regulation
2. protection
3. control fault diagnosis
4. load response control

## 1.1 Voltage regulation

The alternator voltage is compared with a reference voltage in an amplifier, whose output determines the switching frequency of output power MOS whose current excites the coil of the alternator; as the regulator is in fixed-frequency topology, the field switching frequency does not depend on the alternator characteristics. The regulators have an integrated filter in the voltage sensing path guaranteeing the correct behaviour of the devices also when the rectifier diodes feature very high switching spikes. The internal filtering allows the usage of the device also with very long cables connecting the alternator to the battery with an impedance so high to cause a superimposed ripple on the alternator voltage higher than 5-6V. Consequently it doesn't need, in the standard application, any external component. Anyway an external capacitor (2.2 $\mu$ F) must be inserted between A+ and ground when using the device with very long cables.

## 1.2 Protection

It is present a protection against short circuits of the lamp and the relay power drivers (L) and of the field power driver (F+), a thermal drivers shutdown protection and an overvoltage protection of L power drivers.

## 1.3 Diagnosis

The circuit detects fault conditions related to the phase and F+ status and receives informations from one of the three alternator phases. In order to prevent spurious indications, fault warnings are not displayed immediately but are delayed by a fixed time.

## 1.4 Load response control

The internal circuit regulates the soft start characteristics (activated always at engine start) and the soft attack characteristics.

## 2 Pin description

Figure 1. Pin connection (top view)

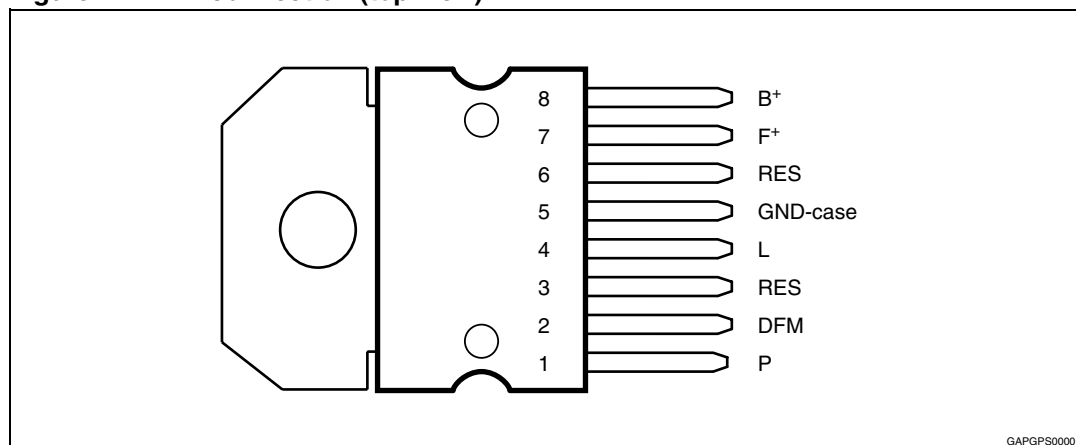

Table 2. Pin description

N°	Pin	Function
1	P	Phase sense input.
2	DFM	Field monitor output.
3	RES	Reserved.
4	L	Lamp terminal low side driver; relay terminal high side driver.
5	GND-case	Ground.
6	RES	Reserved.
7	F+	High side driver output.
8	B+	Sensed power supply.

## 3 Electrical specification

### 3.1 Absolute maximum ratings

$T_j = -40$  to  $150$  °C, unless otherwise specified.

**Table 3. Absolute maximum ratings**

Symbol	Parameter	Value	Unit
$V_S$	DC supply voltage (2 min. @ $25$ °C)	24	V
-	Transient supply voltage (load dump) [see <a href="#">Figure 8</a> ] $t < 500$ ms	40	V
-	Transient supply voltage (low energy spikes) (see <a href="#">Figure 8</a> ) ISO7637-1 pulse 1,2,3 /ISO7637-3	60	V
$T_j$	Junction temperature range	-40 to 150	°C
$T_{stg}, T_{case}$	Storage and case temperature range	-40 to 150	°C
$P_{tot}$	Total power dissipation (@ $T_{case} \leq 150$ °C, $I_{field} \leq 5$ A)	4	W
-	Reverse battery voltage (see <a href="#">Figure 8</a> ) @ $25$ °C, $T = 15$ sec.	-2.5	V
-	Normal working condition reverse voltage (P vs. GND)	-1.5	V
-	DC pin current on F+, B+, GND (bonding limitation)	15	A
-	ESD voltage MILSTD883C (All pins vs.GND)	$\pm 4$	KV

### 3.2 Thermal data

**Table 4. Thermal data**

Symbol	Parameter	Value	Unit
$R_{th j-case}$	Thermal resistance junction-to-case	$\leq 1.5$	°C/W

### 3.3 Electrical characteristics

$T_j = -40$  °C to  $150$  °C; unless otherwise specified.

**Table 5. Electrical characteristics**

Symbol	Parameter	Test condition	Min.	Typ.	Max.	Unit
$V_{bat}$	Operating supply voltage	-	7	-	18	V
$I_{b-sinked}$	Supply battery current	-	-	-	25	mA
$I_{b-stby}$	Stand-by current	$B+ = 12.5$ V, $F+ = 0$ V	-	-	500	$\mu$ A

Table 5. Electrical characteristics (continued)

Symbol	Parameter	Test condition	Min.	Typ.	Max.	Unit
$V_{reg 1}$	Regulated voltage & thermal drift. 3 configurations available, selectable by mask option (see <a href="#">Table 8</a> ).	$I_{alt} = 1 \text{ A} - 0.9 \cdot I_{nom}$ ; $T_{case} = 20 \text{ }^\circ\text{C}$ ; $1400 < \text{rpm} < \text{RPMMAX}$ (see <a href="#">Figure 2</a> )	14.0 -4.5	14.4 -3.5	14.8 -2.5	V mV/ $^\circ\text{C}$
$V_{reg 2}$		$I_{alt} = 10 \text{ A}$ ; $T_{case} = 23 \text{ }^\circ\text{C}$ ; $\text{rpm} = 6000 \text{ rpm}$ ; 15 V max. (see <a href="#">Figure 3</a> )	14.35 -11.8	14.5 -10	14.65 -8.2	V mV/ $^\circ\text{C}$
$V_{reg 3}$		$I_{alt} = 10 \text{ A}$ ; $T_{case} = 23 \text{ }^\circ\text{C}$ ; $\text{rpm} = 6000 \text{ rpm}$ (see <a href="#">Figure 4</a> )	14.35 -6	14.5 -4	14.65 -2	V mV/ $^\circ\text{C}$
$V_{reg 4}$		$I_{alt} = 10 \text{ A}$ ; $T_{case} = 23 \text{ }^\circ\text{C}$ ; $\text{rpm} = 6000 \text{ rpm}$ (see <a href="#">Figure 5</a> )	13.95 -3.5	14.2 -2.5	14.3 -1.5	V mV/ $^\circ\text{C}$
$\Delta V_{rpm}$	-	$1400 < \text{rpm} < \text{RPMMAX}$ ; $I_{alt} = 10 \text{ A}$	-	-	200	mV
$\Delta V_{load}$	-	$5 \text{ A} < I_{alt} < I_{nom}$ ; $\text{rpm} = 6000 \text{ rpm}$	-	-	250	mV
$V_{reg-less}$	Reg. voltage without battery	$I_{alt} = 3 \text{ A}$ resistive; $T_{case} = 25 \text{ }^\circ\text{C}$ ; $2000 < \text{rpm} < \text{RPMMAX}$	12	-	16	V
$V_{ov-p}$	Overvoltage protection threshold	Voltage on pin B+ to disable L drivers High and low side driver off	18	-	22	V
$V_{ov-d}$	Overvoltage diagnosis threshold	VB+ to turn on L low side driver at $V_{F+} > V_{S1}$	$V_{reg} - 5\%$	$V_{reg}$	$V_{reg} + 5\%$	V
$T_{j-sd}$	Thermal shutdown threshold	Temperature to disable F+, DFM, L (high & low side drivers)	160	175	190	$^\circ\text{C}$
$T_{j-sd-dwn}$	Thermal shut-down hysteresis	L/F+/DFM from OFF STATE (due to thermal shutdown) to ON STATE	$T_{j-sd} - 10$	-	$T_{j-sd} - 2$	$^\circ\text{C}$
$V_{uv-1}$	Under voltage diagnosis threshold	VB+ to turn on L low side driver	7.7	8.6	9.5	V
$V_{uv-up}$		VB+ to turn off L low side driver	$V_{uv} + 0.40$	$V_{uv} + 0.75$	$V_{uv} + 1.2$	V
$V_{F+_{sat}}$	Field driver saturation voltage	$T_j = 150 \text{ }^\circ\text{C}$ ; $I = 4.5 \text{ A}$	-	-	0.6	V
		$T_j = 25 \text{ }^\circ\text{C}$ ; $I = 7 \text{ A}$	-	-	0.55	V
$V_f$	Freewheeling diode F+	$I = 5 \text{ A}$	-	-	2	V
$I_{f\_SCTH}$	Field short circuit driver protection threshold current (see <a href="#">Figure 15</a> )	$F+ = 0 \text{ V}$ ; $T_j = -40 \text{ }^\circ\text{C}$	11	-	18	A
		$F+ = 0 \text{ V}$ ; $T_j = -25 \text{ }^\circ\text{C}$	9.5	-	18	A
		$F+ = 0 \text{ V}$ ; $T_j = -150 \text{ }^\circ\text{C}$	9	-	18	A
$V_{s1}$	Field driver ON-state detection	-	4.5	-	5.5	V
$f_{pre}$	Pre-excitation frequency	-	283	333	383	Hz
Duty-pre	Pre-excitation Field driver ON-duty	-	15.93	18.75	21.57	%
$t_r$	Output voltage rise time	$I_{field} = 3 \text{ A}$ resistive (see <a href="#">Figure 6</a> )	10	-	50	$\mu\text{s}$
$t_f$	Output voltage fall time		10	-	50	$\mu\text{s}$
$F_{sw\_F+}$	Field switching frequency	$I_{alt} = 1 \text{ A} - 0.9 \cdot I_{nom}$ ; $1400 \text{ rpm} < \text{rpm} < \text{RPMMAX}$	250	-	400	Hz

Table 5. Electrical characteristics (continued)

Symbol	Parameter	Test condition	Min.	Typ.	Max.	Unit
If_leak	Output field driver leakage current	$B_+ = 24\text{ V}; V_{F_+} = 0$	-	-	10	$\mu\text{A}$
DUTY-PR	Phase regulation max field ON duty	see <a href="#">Figure 7</a>	26.56	31.25	35.94	%
$V_{H\_SAT}$	High side driver saturation Voltage (see <a href="#">Figure 9</a> )	With driver $I_{source} = 500\text{ mA}$	-	-	1.5	V
$V_{L\_SAT}$	Low side driver saturation voltage (see <a href="#">Figure 9</a> )	With driver $I_{sink} = 500\text{ mA}$	-	-	1.5	V
$V_{LSB}$	Self bias without supply lamp driver voltage	$B_+$ open; L connected to 12 V through a 50 Ohm resistor	-	-	4	V
$I_{HSC}$	High side driver short circuit current protection	$B_+ = 12.5\text{ V}; L = \text{GND}$	1.2	-	3	A
$I_{LSC}$	Low side driver short circuit current (see <a href="#">Figure 15</a> )	$B_+ = L = 12.5\text{ V}$	1	-	2	A
$V_{thL}$	Enable regulator supply voltage threshold	-	0.8	-	1.15	V
$I_{pd\_L}$	L terminal pull-down current when the generator is not rotating	$V_L = 0.6\text{ V}$	0.4	-	3.5	mA
$I_{L\_sink}$	L sink current when the generator is rotating	P frequency 500 Hz; $V_{B_+} = 12\text{ V}$	-	-	100	$\mu\text{A}$
$t_D$	Diagnostic alarm delay time	-	0.2	-	0.5	s
$V_{can\text{-DFM}}$	Test mode to cancel soft start/attack (voltage)	(see <a href="#">Figure 10</a> )	30	-	50	V
$t_{can\text{-DFM}}$	Test mode delay time		25	-	-	ms
$V_{PHL1}$	Enable control voltage input high threshold	-	-	-	0.40	V
$V_{PHL2}$	Enable control voltage input low threshold	-	-	-	0.25 <sup>(1)</sup>	V
$t_{PHL1}$	Enable Control Voltage Phase Filtering Time	-	50	-	115	$\mu\text{s}$
$V_{PHH1}$	Diagnosis phase loss input high threshold	-	8	9	10	V
$V_{PHH2\_1}$	Diagnosis phase loss input low threshold	-	6.4	7.4	8.4	V
$t_{PHd}$	Diagnostic phase filtering time	-	50	-	100	$\mu\text{s}$
$I_{Pd\text{-P1}}$	Phase pull-down current	$V_P = 0.8\text{ V}$	1	-	8	mA
$f_{\text{-dfm}}$	DFM output open drain switching freq.	$I_{alt} = 1\text{ A} \sim 0.9 \cdot I_{nom}$ ; 1400 rpm < rpm < RPMMAX; $I_{sink} = 4\text{ mA}$	125	-	200	Hz
$V_{L\text{-DFM}}$	Output low voltage saturation	$I_{\text{-sink}} = 14\text{ mA}$	-	-	1.5	V
$I_{SC\_DFM}$	Short circuit current protection	$V_{B_+} = V_{DFM} = 12.5\text{ V}$	50	-	400	mA
$I_{lk\text{-DFM}}$	Output leakage current	$V_{DFM} = 16\text{ V}$ at DFM driver OFF	-	-	5	$\mu\text{A}$

**Table 5. Electrical characteristics (continued)**

Symbol	Parameter	Test condition	Min.	Typ.	Max.	Unit
t <sub>TM</sub>	Output voltage rise time	R = 1 kΩ (see <a href="#">Figure 6</a> )	0.5	-	50	μs
t <sub>TD</sub>	Output voltage fall time		0.5	-	50	

1. Guaranteed by design.

**Table 6. Load response control parameters**

Symbol	Parameter	Test Condition	Min.	Typ.	Max.	Unit
t <sub>ST_1</sub>	Soft start delay time (see <a href="#">Figure 12</a> ) 2 steps available, selectable by mask option (see <a href="#">Table 7</a> ).	Activated always at engine start	-	0-	-	s
t <sub>ST_2</sub>			1.73	2	2.35	s
t <sub>SL_1</sub>	Soft attack time / soft start time (see <a href="#">Figure 12</a> ). 2 steps available, selectable by mask option (see <a href="#">Table 7</a> ).	From 0 to 100 % field duty cycle	2.13	2.5	2.87	s
t <sub>SL_2</sub>			7.65	9	10.35	
EN-RES (constant)	Reset frequency range to enable regulation; Frequency judged after 4 periods (see <a href="#">Figure 11</a> )	-	40	50	60	Hz
EN-1	Soft start enable (EN) and LRC disable (DISAB) frequency ranges. 4 configurations available, selectable by mask option (possible combinations in <a href="#">Table 8</a> ). Always activated at engine start. Frequencies judged after 4 periods (see <a href="#">Figure 11</a> )	T <sub>j</sub> = 25 °C	108	120	132	Hz
		T <sub>j</sub> = -40 to150 °C	102	120	138	Hz
EN-2		T <sub>j</sub> = 25 °C	131	145	159	Hz
		T <sub>j</sub> = -40 to150 °C	124	145	166	Hz
EN-3		T <sub>j</sub> = 25 °C	144	160	176	Hz
		T <sub>j</sub> = -40 to150 °C	136	160	184	Hz
EN-4		T <sub>j</sub> = 25 °C	174	193	212	Hz
		T <sub>j</sub> = -40 to150 °C	165	193	221	Hz
DISAB-1		T <sub>j</sub> = 25 °C	270	300	330	Hz
		T <sub>j</sub> = -40 to150 °C	255	300	345	Hz
DISAB-2	T <sub>j</sub> = 25 °C	315	350	385	Hz	
	T <sub>j</sub> = -40 to150 °C	298	350	402	Hz	
DISAB-3	T <sub>j</sub> = 25 °C	367	408	449	Hz	
	T <sub>j</sub> = -40 to150 °C	347	408	469	Hz	
DISAB-4	T <sub>j</sub> = 25 °C	420	466	512	Hz	
	T <sub>j</sub> = -40 to150 °C	397	466	535	Hz	

**Table 7. Load response control timing options**

-	t <sub>SL</sub> = 2.5 s	t <sub>SL</sub> = 9 s
t <sub>ST</sub> = 0 s	LRC-A	LRC-D
t <sub>ST</sub> = 0.5 s	LRC-C	-
t <sub>ST</sub> = 2 s	LRC-E	LRC-B

**Table 8. Correspondence of frequency (typical values) to application features**

Alternator revolution speed (rpm)			6 pole pairs	8 pole pairs
Typical configuration A (Config-A)	Initiate regulation	1200	EN-1	EN-3
	LRC Cut	3000	DISAB-1	DISAB-3
Typical configuration B (Config-B)	Initiate Regulation	1450	EN-2	EN-4
	LRC Cut	3000	DISAB-1	DISAB-3
Typical configuration C (Config-C)	Initiate Regulation	1450	EN-2	EN-4
	LRC Cut	3500	DISAB-2	EN-4

Considering the overall WW application scenario, there is a direct correspondence between Typical configurations A/B and regulation curve Vreg-1, and between typical configuration C and regulation curves V<sub>reg-2</sub> and V<sub>reg-3</sub>. This is allowing the summary of all possible customization for L9911 in the table below.

**Table 9. Customization of L9911: combination of LRC, regulation, and application options**

LRC timing options	Vreg-1/Config-A		Vreg-1/Config-B		Vreg-2/Config-B		Vreg-2/Config-A		Vreg-4/Config-A	
	6 Pole Pairs	8 Pole Pairs	6 Pole Pairs	8 Pole Pairs	6 Pole Pairs	8 Pole Pairs	6 Pole Pairs	8 Pole Pairs	6 Pole Pairs	8 Pole Pairs
<b>LRC-A</b>	<b>L9911P</b>	nya	nya	nya	nya	nya	nya	nya	<b>L9911K</b>	nya
<b>LRC-B</b>	nya	nya	<b>L9911F</b>	nya	<b>L9911I</b>	nya	nya	nya	nya	nya
<b>LRC-C</b>	nya	nya	nya	nya	nya	nya	<b>L9911V</b>	nya	nya	nya
<b>LRC-D</b>	nya	nya	nya	nya	nya	nya	nya	nya	nya	nya
<b>LRC-E</b>	<b>L9911U</b>	nya	nya	nya	nya	nya	nya	nya	nya	nya

**Figure 2. V<sub>reg-1</sub>**

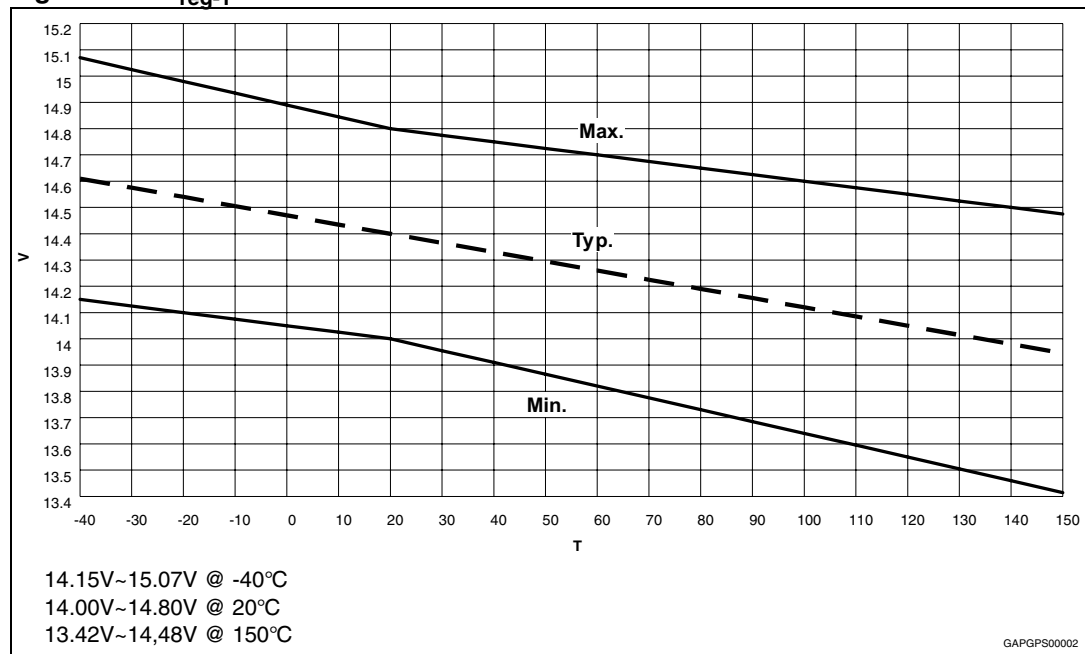

Figure 3.  $V_{reg-2}$

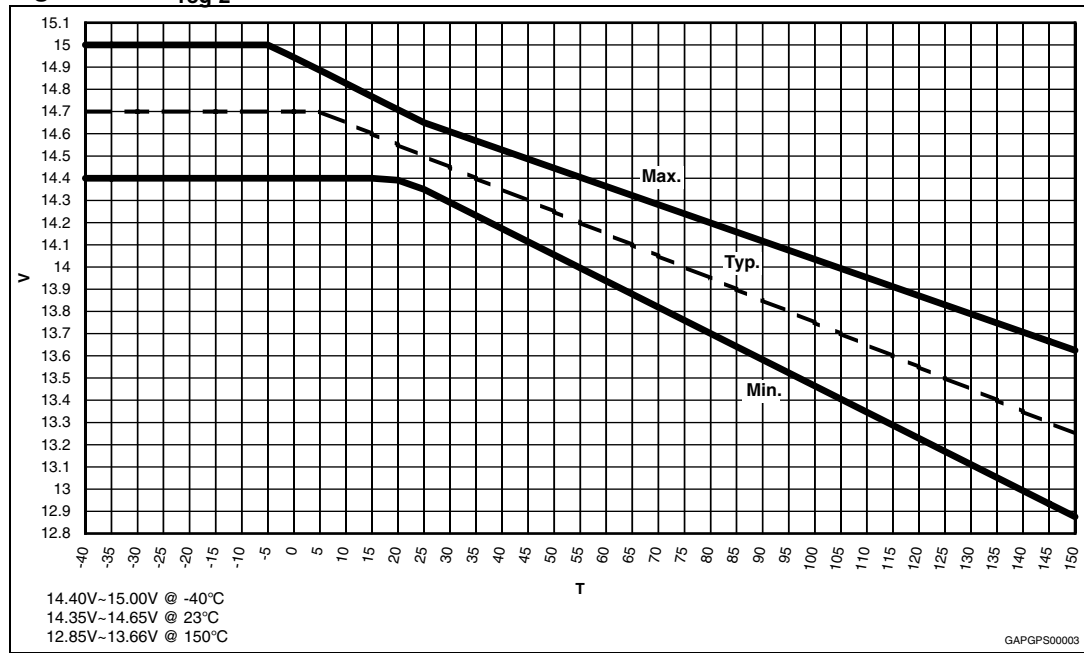

Figure 4.  $V_{reg-3}$

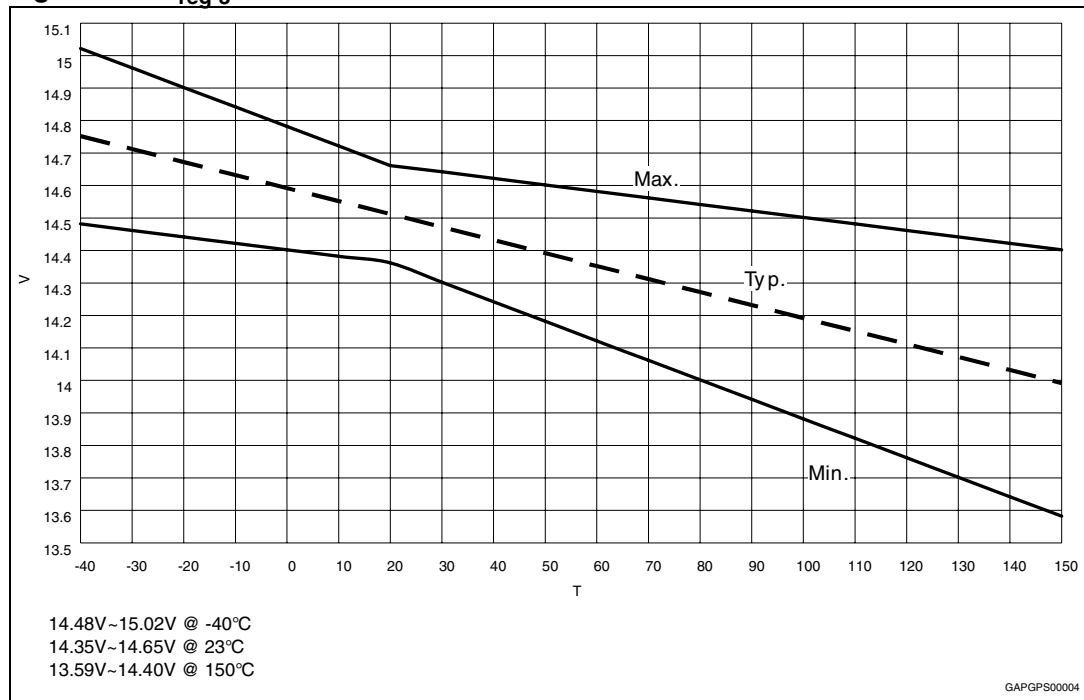

Figure 5.  $V_{reg-4}$

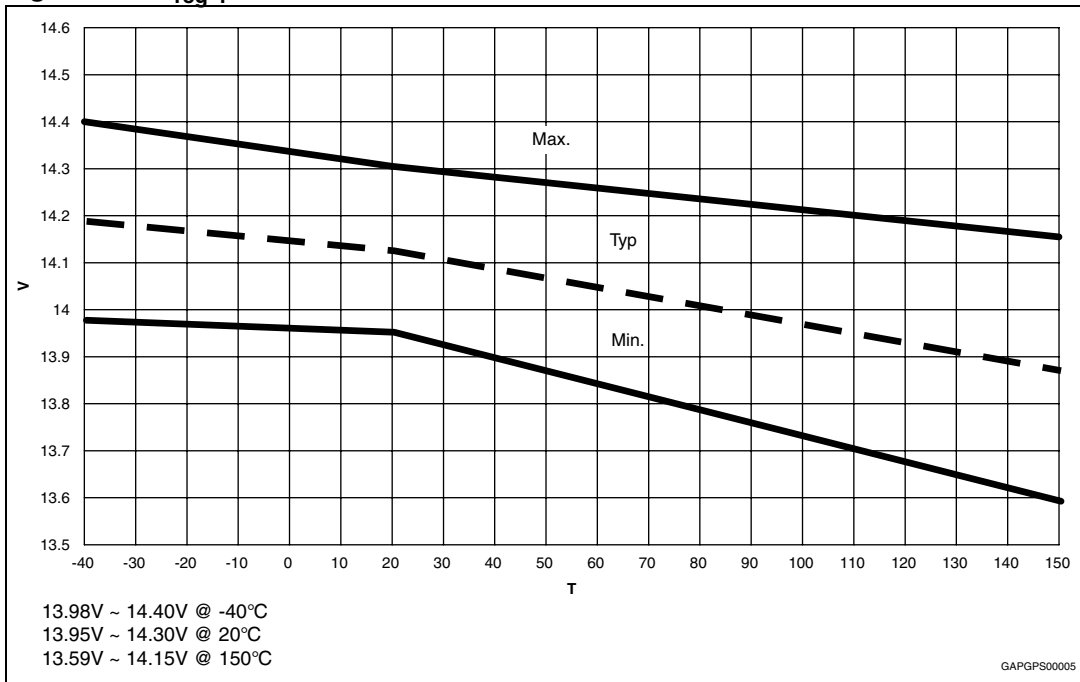

Figure 6. Output voltage rise/fall time (F+, DFM)

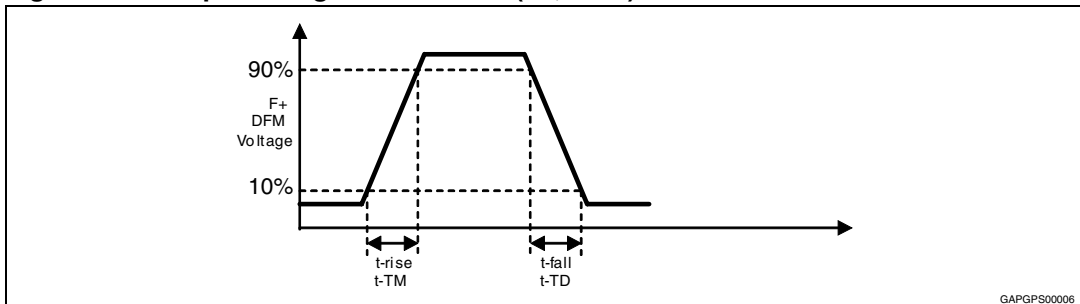
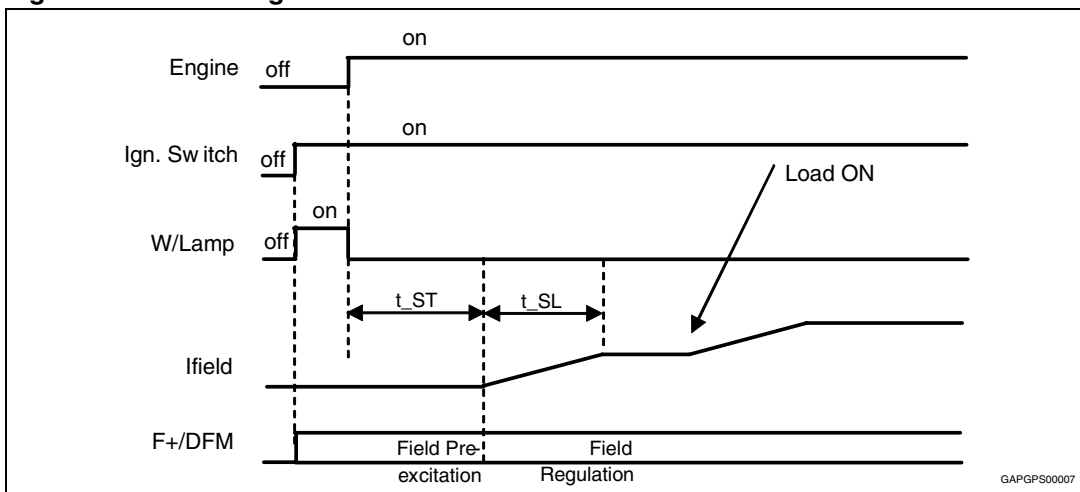

Figure 7. Phase regulation characteristics



### 3.4 Principle of phase regulation

When  $V_{B+}$  is above the regulated voltage, the field driver is controlled to keep phase peak voltage from falling below  $V_{PHH1}$ .

If phase peak voltage drops below  $V_{PHL1}$ , phase regulation does not work.

**Figure 8. Application diagram**

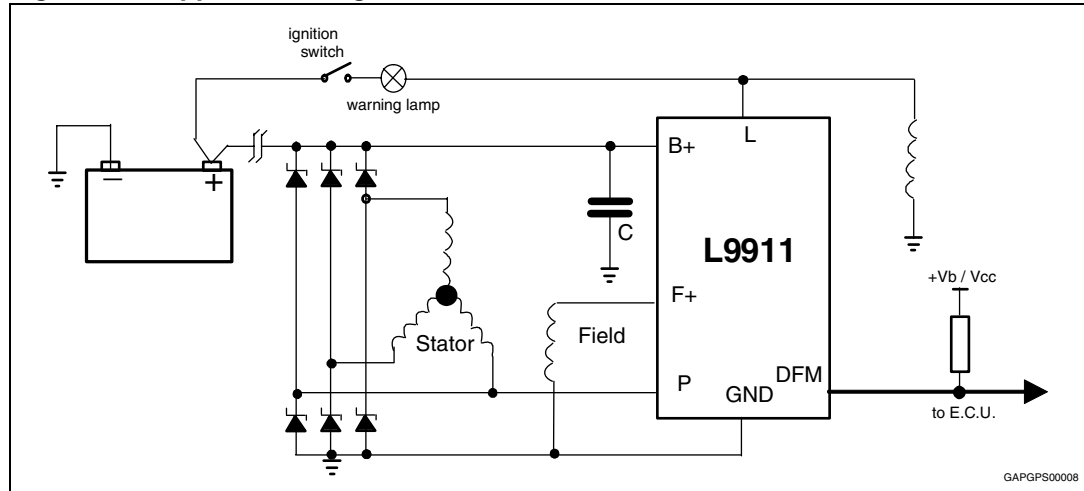

**Figure 9. High side/low side driver saturation**

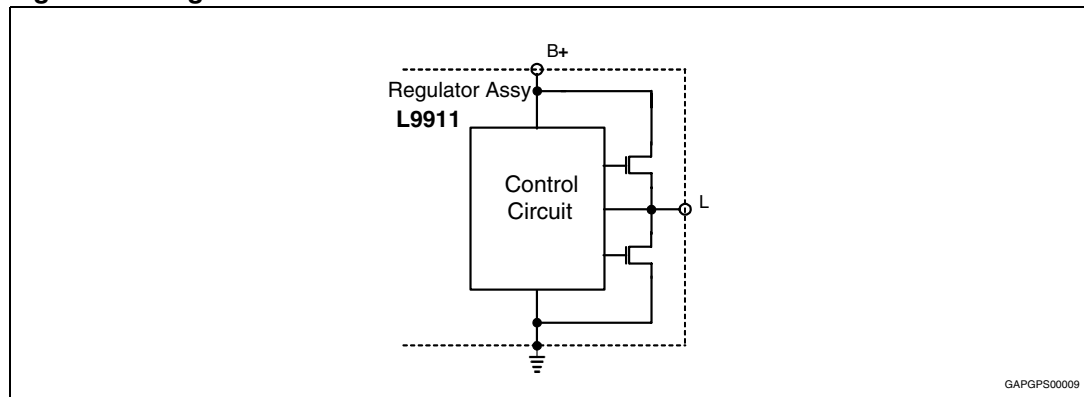

**Figure 10. Test mode to cancel soft-start/attack**

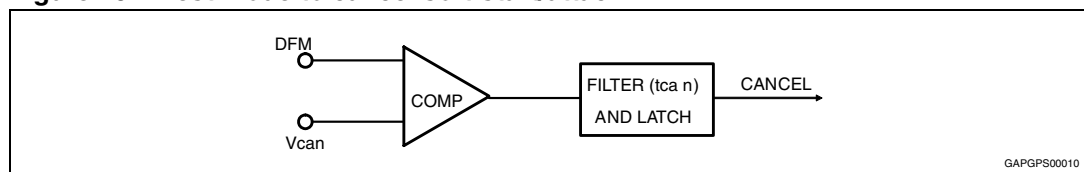

**Figure 11. Soft-start enable frequency range**

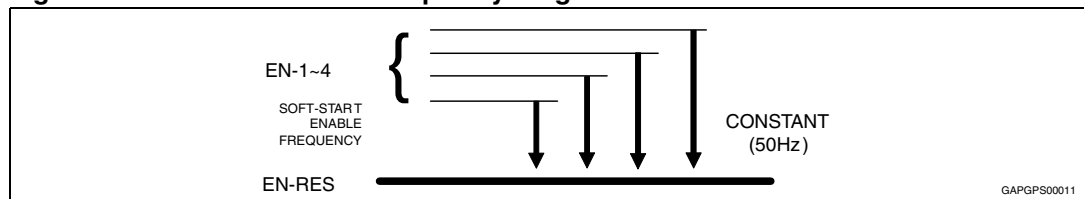

Figure 12. Soft-start characteristics (always activated at engine start)

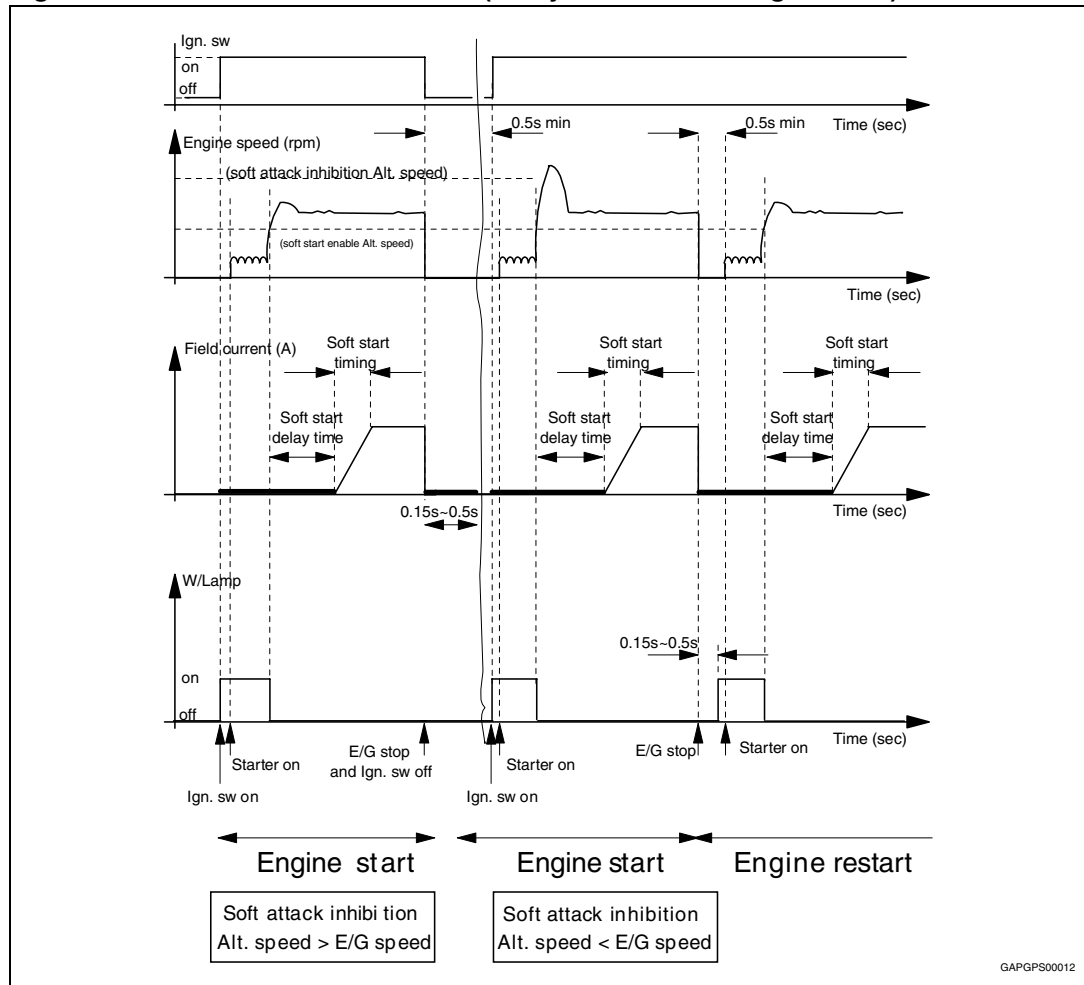
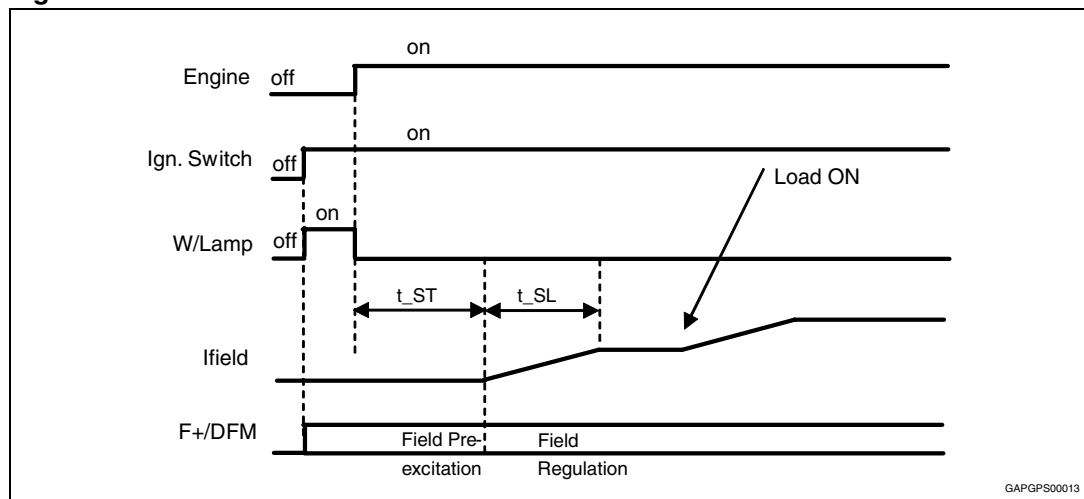

Figure 13. Soft start/attack characteristics

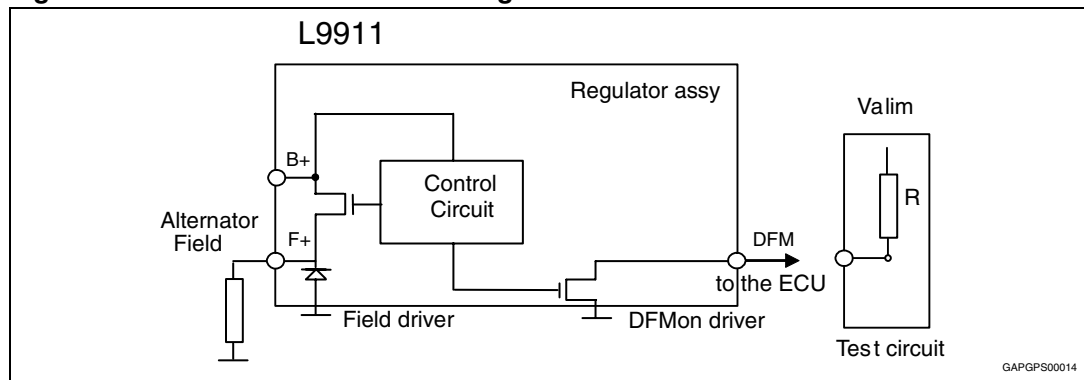

**Table 10. Fault detection**

Root cause	Signal	Effect	Test detect
Alternator belt breaking	P	Alternator disexcitation	VP<VPHH1 & VB+<Vreg
Brushes open	P	Alternator disexcitation	VP<VPHH1 & VB+<Vreg
Field driver open	P	Alternator disexcitation	VP<VPHH1 & VB+<Vreg
Field interruption	P	Alternator disexcitation	VP<VPHH1 & VB+<Vreg
Field short circuit to the battery	F+	Overvoltage	VF+>VS1 & VB+ > Vov-d
Field short circuit to the ground	P	Alternator disexcitation	VP<VPHH1 & VB+<Vreg
Battery discharge	B+	Undervoltage	VB+<Vuv

*Note:* The diagnostic result is disabled during the Soft-start delay time  $t_{ST} 0...3$  and the soft-start / soft attack timing  $t_{SL} 0...3$

**Figure 14. DF monitor electrical configuration**



**Figure 15. Short circuit drivers' protection**

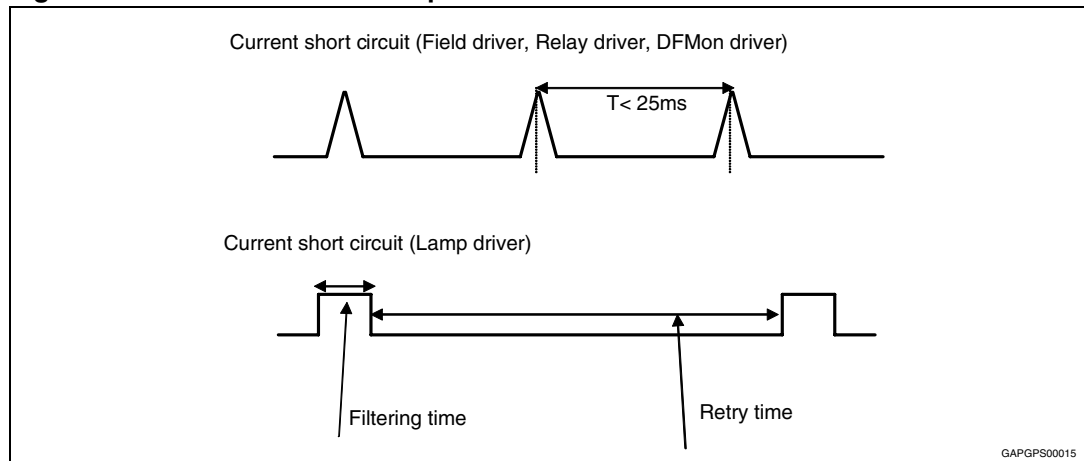

Field driver, DFMon driver and Relay driver are protected in switching mode (not linear), with a retry time less than 25 ms.

Lamp driver is protected in linear mode, with a retry time of 1 s.

# 4 Package information

In order to meet environmental requirements, ST offers these devices in different grades of ECOPACK® packages, depending on their level of environmental compliance. ECOPACK® specifications, grade definitions and product status are available at: [www.st.com](http://www.st.com).

ECOPACK® is an ST trademark.

**Figure 16. Multiwatt8 mechanical data and package dimensions**

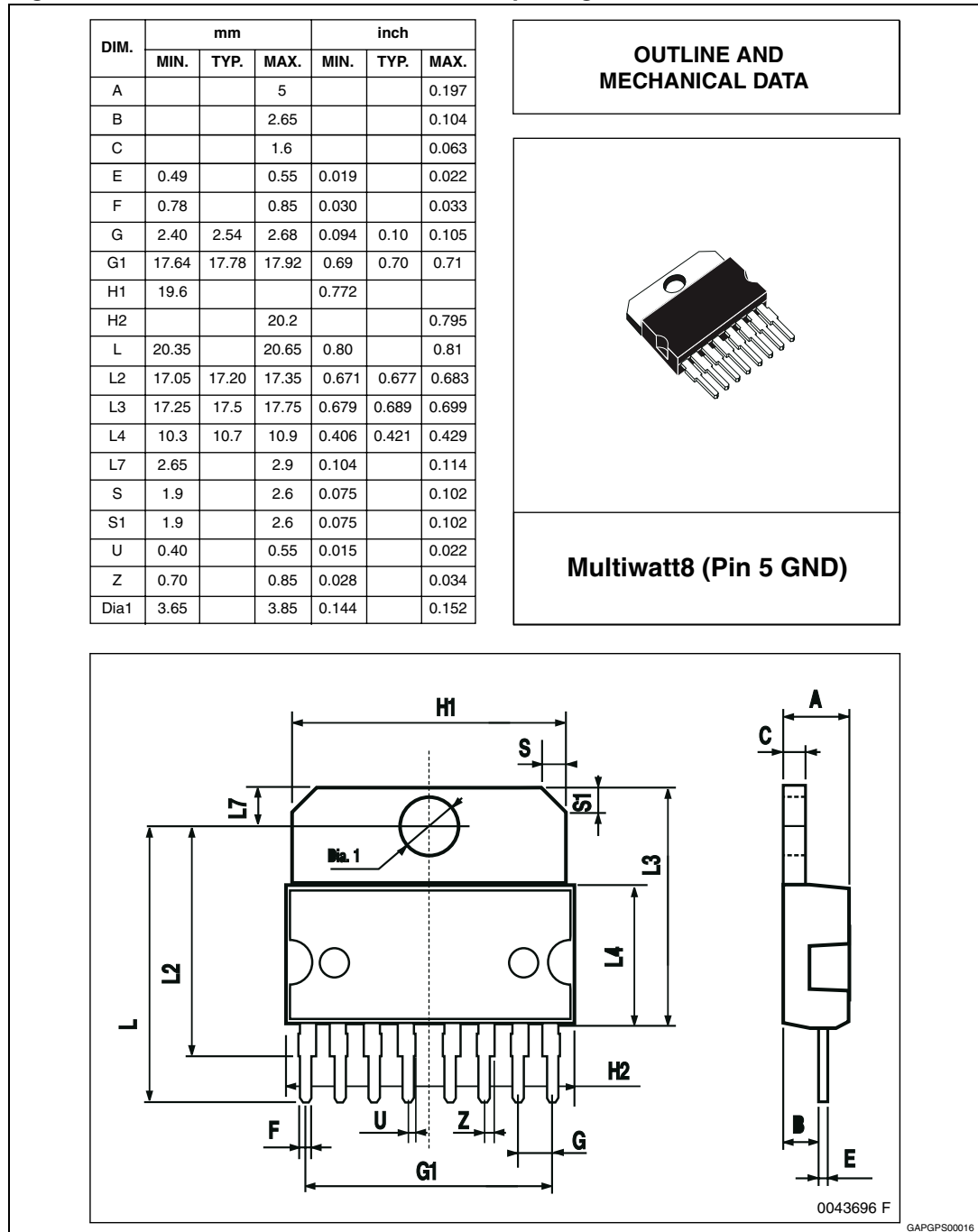

## 5 Revision history

**Table 11. Document revision history**

Date	Revision	Changes
22-Jun-2004	1	Initial release.
18-May-2005	2	Modified Figure 2, Table 2 and Table 5; Updated Figure 10, 11 and 14; Add Table 7. Add ordering numbers.
07-Nov-2005	3	Updated Table 5. Added new tables 6-9.
28-Nov-2005	4	Added the L9911C part number. Updated the Table 9.
11-Jul-2007	5	Document reformatted. Updated order codes, see <a href="#">Table 1: Device summary</a> .
09-Nov-2009	6	Updated <a href="#">Table 1: Device summary</a> , <a href="#">Table 7: Load response control timing options</a> and <a href="#">Table 9: Customization of L9911: combination of LRC, regulation, and application options</a> .
23-Jul-2010	7	Updated <a href="#">Table 1: Device summary</a> , <a href="#">Table 5: Electrical characteristics</a> and <a href="#">Table 9: Customization of L9911: combination of LRC, regulation, and application options</a> . Updated <a href="#">Figure 2, 3 and 4</a> . Added new <a href="#">Figure 5</a> .
25-Jan-2011	8	Updated <a href="#">Table 5: Electrical characteristics</a> . Updated <a href="#">Figure 5</a> .
29-Mar-2011	9	Modified in the <a href="#">Table 5: Electrical characteristics</a> the values of the “V <sub>uv-up</sub> ” parameter.
26-Mar-2012	10	Updated: <a href="#">Table 1: Device summary on page 1</a> ; <a href="#">Table 7: Load response control timing options on page 10</a> ; <a href="#">Table 9: Customization of L9911: combination of LRC, regulation, and application options on page 11</a> .
28-May-2012	11	Updated <a href="#">Table 9: Customization of L9911: combination of LRC, regulation, and application options on page 11</a> .

**Please Read Carefully:**

Information in this document is provided solely in connection with ST products. STMicroelectronics NV and its subsidiaries ("ST") reserve the right to make changes, corrections, modifications or improvements, to this document, and the products and services described herein at any time, without notice.

All ST products are sold pursuant to ST's terms and conditions of sale.

Purchasers are solely responsible for the choice, selection and use of the ST products and services described herein, and ST assumes no liability whatsoever relating to the choice, selection or use of the ST products and services described herein.

No license, express or implied, by estoppel or otherwise, to any intellectual property rights is granted under this document. If any part of this document refers to any third party products or services it shall not be deemed a license grant by ST for the use of such third party products or services, or any intellectual property contained therein or considered as a warranty covering the use in any manner whatsoever of such third party products or services or any intellectual property contained therein.

**UNLESS OTHERWISE SET FORTH IN ST'S TERMS AND CONDITIONS OF SALE ST DISCLAIMS ANY EXPRESS OR IMPLIED WARRANTY WITH RESPECT TO THE USE AND/OR SALE OF ST PRODUCTS INCLUDING WITHOUT LIMITATION IMPLIED WARRANTIES OF MERCHANTABILITY, FITNESS FOR A PARTICULAR PURPOSE (AND THEIR EQUIVALENTS UNDER THE LAWS OF ANY JURISDICTION), OR INFRINGEMENT OF ANY PATENT, COPYRIGHT OR OTHER INTELLECTUAL PROPERTY RIGHT.**

**UNLESS EXPRESSLY APPROVED IN WRITING BY TWO AUTHORIZED ST REPRESENTATIVES, ST PRODUCTS ARE NOT RECOMMENDED, AUTHORIZED OR WARRANTED FOR USE IN MILITARY, AIR CRAFT, SPACE, LIFE SAVING, OR LIFE SUSTAINING APPLICATIONS, NOR IN PRODUCTS OR SYSTEMS WHERE FAILURE OR MALFUNCTION MAY RESULT IN PERSONAL INJURY, DEATH, OR SEVERE PROPERTY OR ENVIRONMENTAL DAMAGE. ST PRODUCTS WHICH ARE NOT SPECIFIED AS "AUTOMOTIVE GRADE" MAY ONLY BE USED IN AUTOMOTIVE APPLICATIONS AT USER'S OWN RISK.**

Resale of ST products with provisions different from the statements and/or technical features set forth in this document shall immediately void any warranty granted by ST for the ST product or service described herein and shall not create or extend in any manner whatsoever, any liability of ST.

ST and the ST logo are trademarks or registered trademarks of ST in various countries.

Information in this document supersedes and replaces all information previously supplied.

The ST logo is a registered trademark of STMicroelectronics. All other names are the property of their respective owners.

© 2012 STMicroelectronics - All rights reserved

STMicroelectronics group of companies

Australia - Belgium - Brazil - Canada - China - Czech Republic - Finland - France - Germany - Hong Kong - India - Israel - Italy - Japan - Malaysia - Malta - Morocco - Philippines - Singapore - Spain - Sweden - Switzerland - United Kingdom - United States of America

[www.st.com](http://www.st.com)

