

## Single-channel high side driver

### Features

Type	R <sub>DS(on)</sub>	I <sub>OUT</sub>	V <sub>CC</sub>
VN920-E	16 mΩ	30 A	36 V
VN920-12-E			

- CMOS compatible input
- Proportional load current sense
- Shorted load protection
- Under voltage and overvoltage shutdown
- Overvoltage clamp
- Thermal shutdown
- Current limitation
- Protection against loss of ground and loss of V<sub>CC</sub>
- Very low standby power dissipation
- Reverse battery protected (see [Application schematic on page 16](#))
- In compliance with the 2002/95/ec european directive

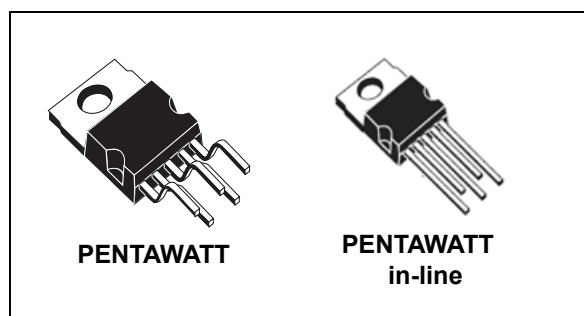

### Description

The VN920-E is a monolithic device designed in STMicroelectronics VIPower™ M0-3 technology, intended for driving any kind of load with one side connected to ground. Active V<sub>CC</sub> pin voltage clamp protects the device against low energy spikes (see ISO7637 transient compatibility able).

Active current limitation combined with thermal shutdown and automatic restart protect the device against overload. The device integrates an analog current sense output which delivers a current proportional to the load current. Device automatically turns off in case of ground pin disconnection.

**Table 1. Device summary**

Package	Order codes	
	Tube	Tape and reel
PENTAWATT	VN920-E	-
PENTAWATT in-line	VN920-12-E	-

# Contents

<b>1</b>	<b>Block diagram and pin description</b>	<b>5</b>
<b>2</b>	<b>Electrical specifications</b>	<b>6</b>
2.1	Absolute maximum ratings	6
2.2	Thermal data	7
2.3	Electrical characteristics	7
2.4	Electrical characteristics curves	14
<b>3</b>	<b>Application information</b>	<b>16</b>
3.1	GND protection network against reverse battery	16
3.1.1	Solution 1: resistor in the ground line (RGND only)	16
3.1.2	Solution 2: diode (DGND) in the ground line	17
3.2	Load dump protection	17
3.3	MCU I/Os protection	17
<b>4</b>	<b>Package and packing information</b>	<b>18</b>
4.1	ECOPACK® packages	18
4.1.1	PENTAWATT (vertical) mechanical data	18
4.1.2	PENTAWATT (in-line) mechanical data	20
4.2	PENTAWATT packing information	21
<b>5</b>	<b>Revision history</b>	<b>22</b>

## List of tables

Table 1.	Device summary . . . . .	1
Table 2.	Suggested connections for unused and not connected pins . . . . .	5
Table 3.	Absolute maximum ratings . . . . .	6
Table 4.	Thermal data. . . . .	7
Table 5.	Power . . . . .	7
Table 6.	Switching ( $V_{CC}=13V$ ) . . . . .	8
Table 7.	Logic inputs. . . . .	8
Table 8.	$V_{CC}$ output diode. . . . .	8
Table 9.	Protections . . . . .	8
Table 10.	Current sense (9V $\times$ VCC $\times$ 16V) . . . . .	9
Table 11.	Truth table. . . . .	11
Table 12.	Electrical transient requirements (part 1/3). . . . .	11
Table 13.	Electrical transient requirements (part 2/3). . . . .	11
Table 14.	Electrical transient requirements (part 3/3). . . . .	12
Table 15.	PENTAWATT (vertical) mechanical data . . . . .	18
Table 16.	PENTAWATT (in-line) mechanical data . . . . .	20
Table 17.	Document revision history . . . . .	22

## List of figures

Figure 1.	Block diagram . . . . .	5
Figure 2.	Configuration diagram (top view) . . . . .	5
Figure 3.	Current and voltage conventions . . . . .	6
Figure 4.	$I_{OUT}/I_{SENSE}$ versus $I_{OUT}$ . . . . .	10
Figure 5.	Switching characteristics . . . . .	10
Figure 6.	Waveforms . . . . .	13
Figure 7.	Off-state output current . . . . .	14
Figure 8.	High level input current . . . . .	14
Figure 9.	Input clamp voltage . . . . .	14
Figure 10.	On-state resistance vs $V_{CC}$ . . . . .	14
Figure 11.	On-state resistance vs $T_{CASE}$ . . . . .	14
Figure 12.	Input high level voltage . . . . .	14
Figure 13.	Input low level voltage . . . . .	15
Figure 14.	Input hysteresis voltage . . . . .	15
Figure 15.	Turn-on voltage slope . . . . .	15
Figure 16.	Turn-off voltage slope . . . . .	15
Figure 17.	Overshoot shutdown . . . . .	15
Figure 18.	ILIM vs Tcase . . . . .	15
Figure 19.	Application schematic . . . . .	16
Figure 20.	PENTAWATT (vertical) package dimensions . . . . .	18
Figure 21.	PENTAWATT (in-line) package dimensions . . . . .	20
Figure 22.	PENTAWATT tube shipment (no suffix) . . . . .	21

# 1 Block diagram and pin description

Figure 1. Block diagram

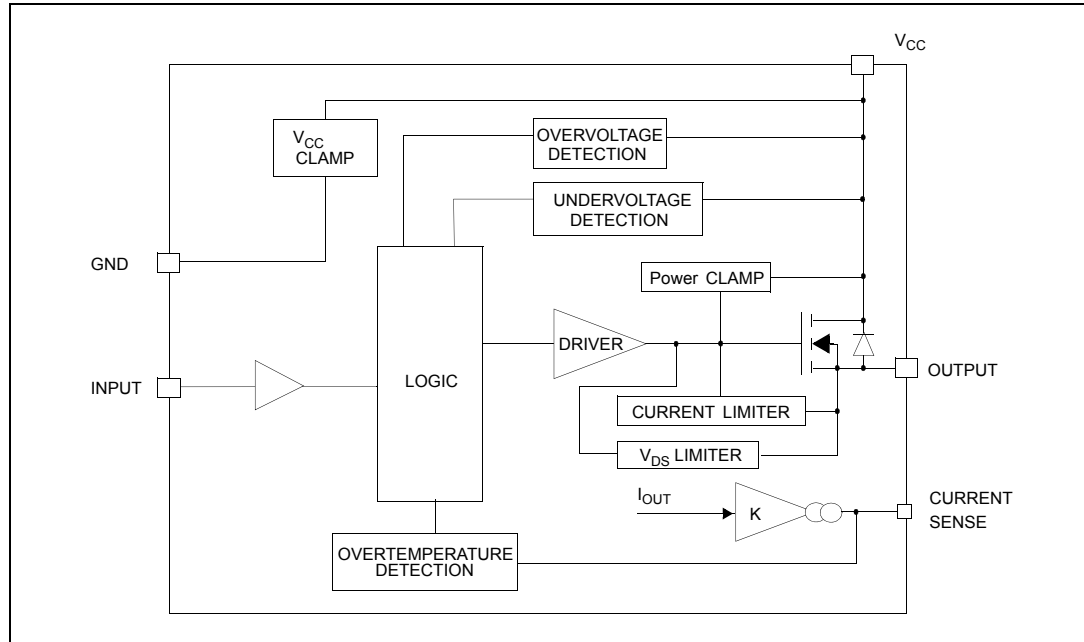

Figure 2. Configuration diagram (top view)

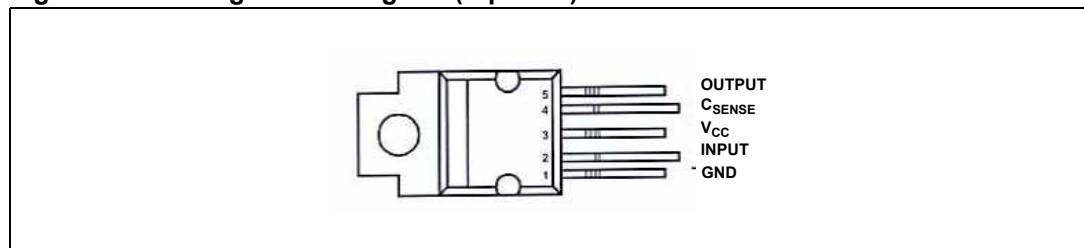
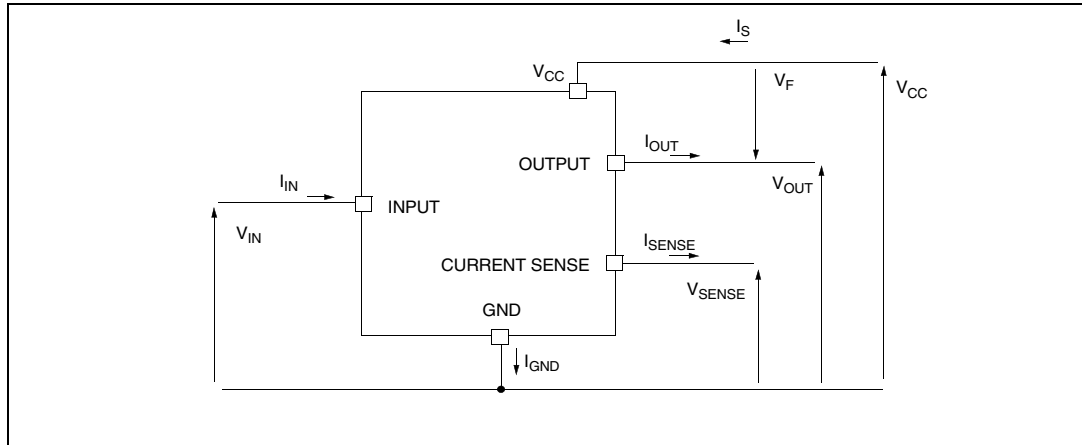

Table 2. Suggested connections for unused and not connected pins

Connection / pin	Current Sense	N.C.	Output	Input
Floating		X	X	X
To ground	Through 1KΩ resistor	X		Through 10KΩ resistor

## 2 Electrical specifications

Figure 3. Current and voltage conventions



### 2.1 Absolute maximum ratings

Stressing the device above the rating listed in the “Absolute maximum ratings” table may cause permanent damage to the device. These are stress ratings only and operation of the device at these or any other conditions above those indicated in the operating sections of this specification is not implied. Exposure to Absolute maximum rating conditions for extended periods may affect device reliability. Refer also to the STMicroelectronics sure program and other relevant quality document.

Table 3. Absolute maximum ratings

Symbol	Parameter	Value	Unit
$V_{CC}$	DC supply voltage	41	V
$-V_{CC}$	Reverse DC supply voltage	- 0.3	V
$-I_{gnd}$	DC reverse ground pin current	- 200	mA
$I_{OUT}$	DC output current	Internally limited	A
$-I_{OUT}$	Reverse DC output current	- 21	A
$I_{IN}$	DC input current	+/- 10	mA
$V_{CSENSE}$	Current sense maximum voltage	- 3 + 15	V V
$V_{ESD}$	Electrostatic discharge (human body model: $R = 1.5K\Omega$ ; $C = 100pF$ )		
	- Input	4000	V
	- Current sense	2000	V
	- Output	5000	V
	$-V_{CC}$	5000	V

Table 3. Absolute maximum ratings (continued)

Symbol	Parameter	Value	Unit
$E_{MAX}$	Maximum switching energy ( $L = 0.25\text{mH}$ ; $R_L = 0\Omega$ ; $V_{bat} = 13.5\text{V}$ ; $T_{jstart} = 150^\circ\text{C}$ ; $I_L = 45\text{A}$ )		mJ
$P_{tot}$	Power dissipation $T_C \leq 25^\circ\text{C}$	96.1	W
$T_j$	Junction operating temperature	Internally limited	$^\circ\text{C}$
$T_C$	Case operating temperature	- 40 to 150	$^\circ\text{C}$
$T_{stg}$	Storage temperature	- 55 to 150	$^\circ\text{C}$

## 2.2 Thermal data

Table 4. Thermal data

Symbol	Parameter	Max. value	Unit
$R_{thj-case}$	Thermal resistance junction-case (max)	1.3	$^\circ\text{C}/\text{W}$
$R_{thj-lead}$	Thermal resistance junction-lead (max)	-	$^\circ\text{C}/\text{W}$
$R_{thj-amb}$	Thermal resistance junction-ambient (max)	61.3	$^\circ\text{C}/\text{W}$

## 2.3 Electrical characteristics

Values specified in this section are for  $8\text{V} < V_{CC} < 36\text{V}$ ;  $-40^\circ\text{C} < T_j < 150^\circ\text{C}$ , unless otherwise stated.

Table 5. Power

Symbol	Parameter	Test conditions	Min.	Typ.	Max.	Unit
$V_{CC}$	Operating supply voltage		5.5	13	36	V
$V_{USD}$	Undervoltage shutdown		3	4	5.5	V
$V_{OV}$	Overvoltage shutdown		36			V
$R_{ON}$	On-state resistance	$I_{OUT} = 10\text{A}$ ; $T_j = 25^\circ\text{C}$ ; $I_{OUT} = 10\text{A}$ ; $I_{OUT} = 3\text{A}$ ; $V_{CC} = 6\text{V}$			16 32 55	$\text{m}\Omega$ $\text{m}\Omega$ $\text{m}\Omega$
$V_{CLAMP}$	Clamp voltage	$I_{CC} = 20\text{mA}^{(1)}$	41	48	55	V
$I_S$	Supply current	Off-state; $V_{CC} = 13\text{V}$ ; $V_{IN} = V_{OUT} = 0\text{V}$ Off-state; $V_{CC} = 13\text{V}$ ; $V_{IN} = V_{OUT} = 0\text{V}$ ; $T_j = 25^\circ\text{C}$ On-state; $V_{CC} = 13\text{V}$ ; $V_{IN} = 5\text{V}$ ; $I_{OUT} = 0\text{A}$ ; $R_{SENSE} = 3.9\text{ k}\Omega$		10 10	25 20	$\mu\text{A}$ $\mu\text{A}$
$I_{L(off1)}$	Off-state output current	$V_{IN} = V_{OUT} = V_{SENSE} = 0\text{V}$	0		50	$\mu\text{A}$

**Table 5. Power (continued)**

Symbol	Parameter	Test conditions	Min.	Typ.	Max.	Unit
$I_{L(off2)}$	Off-state output current	$V_{IN} = V_{OUT} = V_{SENSE} = 3.5V$	-75			$\mu A$
$I_{L(off3)}$	Off-state output current	$V_{IN} = V_{OUT} = V_{SENSE} = 0V$ ; $V_{CC} = 13V$ ; $T_j = 125^\circ C$			5	$\mu A$
$I_{L(off4)}$	Off-state output current	$V_{IN} = V_{OUT} = V_{SENSE} = 0V$ ; $V_{CC} = 13V$ ; $T_j = 25^\circ C$			3	$\mu A$

1.  $V_{clamp}$  and  $V_{OV}$  are correlated. Typical difference is 5V.

**Table 6. Switching ( $V_{CC}=13V$ )**

Symbol	Parameter	Test conditions	Min.	Typ.	Max.	Unit
$t_{d(on)}$	Turn-on delay time	$R_L = 1.3\Omega$ (see <a href="#">Figure 5</a> )	-	50	-	$\mu s$
$t_{d(off)}$	Turn-off delay time	$R_L = 1.3\Omega$ (see <a href="#">Figure 5</a> )	-	50	-	$\mu s$
$dV_{OUT}/dt_{(on)}$	Turn-on voltage slope	$R_L = 1.3\Omega$ (see <a href="#">Figure 5</a> )	-	See <a href="#">Figure 15</a>	-	$V/\mu s$
$dV_{OUT}/dt_{(off)}$	Turn-off voltage slope	$R_L = 1.3\Omega$ (see <a href="#">Figure 5</a> )	-	See <a href="#">Figure 16</a>	-	$V/\mu s$

**Table 7. Logic inputs**

Symbol	Parameter	Test conditions	Min.	Typ.	Max.	Unit
$V_{IL}$	Input low level voltage				1.25	V
$I_{IL}$	Low level input current	$V_{IN} = 1.25V$	1			$\mu A$
$V_{IH}$	Input high-level voltage		3.25			V
$I_{IH}$	High-level input current	$V_{IN} = 3.25V$			10	$\mu A$
$V_{I(hyst)}$	Input hysteresis voltage		0.5			V
$V_{ICL}$	Input clamp voltage	$I_{IN} = 1mA$ $I_{IN} = -1mA$	6	6.8 - 0.7	8	V V

**Table 8.  $V_{CC}$  output diode**

Symbol	Parameter	Test conditions	Min.	Typ.	Max.	Unit
$V_F$	Forward on voltage	$-I_{OUT} = 2A$ ; $T_j = 150^\circ C$	-	-	0.6	V

**Table 9. Protections<sup>(1)</sup>**

Symbol	Parameter	Test conditions	Min.	Typ.	Max.	Unit
$T_{TSD}$	Shutdown temperature		150	175	200	$^\circ C$
$T_R$	Reset temperature		135			$^\circ C$
$T_{hyst}$	Thermal hysteresis		7	15		$^\circ C$
$I_{lim}$	DC short circuit current	$V_{CC} = 13V$ $5V < V_{CC} < 36V$	30	45	75 75	A A

**Table 9. Protections<sup>(1)</sup> (continued)**

Symbol	Parameter	Test conditions	Min.	Typ.	Max.	Unit
$V_{\text{demag}}$	Turn-off output clamp voltage	$I_{\text{OUT}} = 2\text{A}; V_{\text{IN}} = 0\text{V};$ $L = 6\text{mH}$	$V_{\text{CC}} - 41$	$V_{\text{CC}} - 48$	$V_{\text{CC}} - 55$	V
$V_{\text{ON}}$	Output voltage drop limitation	$I_{\text{OUT}} = 1\text{A};$ $T_j = -40^\circ\text{C} \dots 150^\circ\text{C}$		50		mV

1. To ensure long term reliability under heavy over-load or short circuit conditions, protection and related diagnostic signals must be used together with a proper software strategy. If the device operates under abnormal conditions this software must limit the duration and number of activation cycles.

**Table 10. Current sense ( $9\text{V} \leq V_{\text{CC}} \leq 16\text{V}$ )<sup>(1)</sup>**

Symbol	Parameter	Test conditions	Min.	Typ.	Max.	Unit
$K_1$	$I_{\text{OUT}}/I_{\text{SENSE}}$	$I_{\text{OUT}} = 1\text{A}; V_{\text{SENSE}} = 0.5\text{V};$ $T_j = -40^\circ\text{C} \dots 150^\circ\text{C}$	3300	4400	6000	
$dK_1/K_1$	Current sense ratio drift	$I_{\text{OUT}} = 1\text{A}; V_{\text{SENSE}} = 0.5\text{V};$ $T_j = -40^\circ\text{C} \dots 150^\circ\text{C}$	-10		+10	%
$K_2$	$I_{\text{OUT}}/I_{\text{SENSE}}$	$I_{\text{OUT}} = 10\text{A}; V_{\text{SENSE}} = 4\text{V};$ $T_j = -40^\circ\text{C}$ $T_j = 25^\circ\text{C} \dots 150^\circ\text{C}$	4200 4400	4900 4900	6000 5750	
$dK_2/K_2$	Current sense ratio drift	$I_{\text{OUT}} = 10\text{A}; V_{\text{SENSE}} = 4\text{V};$ $T_j = -40^\circ\text{C} \dots 150^\circ\text{C}$	-8		+8	%
$K_3$	$I_{\text{OUT}}/I_{\text{SENSE}}$	$I_{\text{OUT}} = 30\text{A}; V_{\text{SENSE}} = 4\text{V};$ $T_j = -40^\circ\text{C}$ $T_j = 25^\circ\text{C} \dots 150^\circ\text{C}$	4200 4400	4900 4900	5500 5250	
$dK_3/K_3$	Current sense ratio drift	$I_{\text{OUT}} = 30\text{A}; V_{\text{SENSE}} = 4\text{V};$ $T_j = -40^\circ\text{C} \dots 150^\circ\text{C}$	-6		+6	%
$I_{\text{SENSE0}}$	Analog sense leakage current	$V_{\text{CC}} = 6 \dots 16\text{V}; I_{\text{OUT}} = 0\text{A};$ $V_{\text{SENSE}} = 0\text{V};$ $T_j = -40^\circ\text{C} \dots 150^\circ\text{C}$	0		10	$\mu\text{A}$
$V_{\text{SENSE}}$	Max analog sense output voltage	$V_{\text{CC}} = 5.5\text{V}; I_{\text{OUT}} = 5\text{A}; R_{\text{SENSE}} = 10\text{k}\Omega$ $V_{\text{CC}} > 8\text{V}, I_{\text{OUT}} = 10\text{A}; R_{\text{SENSE}} = 10\text{k}\Omega$	2 4			V V
$V_{\text{SENSEH}}$	Sense voltage in over temperature condition	$V_{\text{CC}} = 13\text{V}; R_{\text{SENSE}} = 3.9\text{k}\Omega$		5.5		V
$R_{\text{VSENSEH}}$	Analog sense output impedance in over temperature condition	$V_{\text{CC}} = 13\text{V}; T_j > T_{\text{TSD}};$ output open		400		$\Omega$
$t_{\text{DSENSE}}$	Current sense delay response	To 90% $I_{\text{SENSE}}$ <sup>(2)</sup>			500	$\mu\text{s}$

1. See [Figure 4](#).

2. Current sense signal delay after positive input slope.

Figure 4.  $I_{OUT}/I_{SENSE}$  versus  $I_{OUT}$

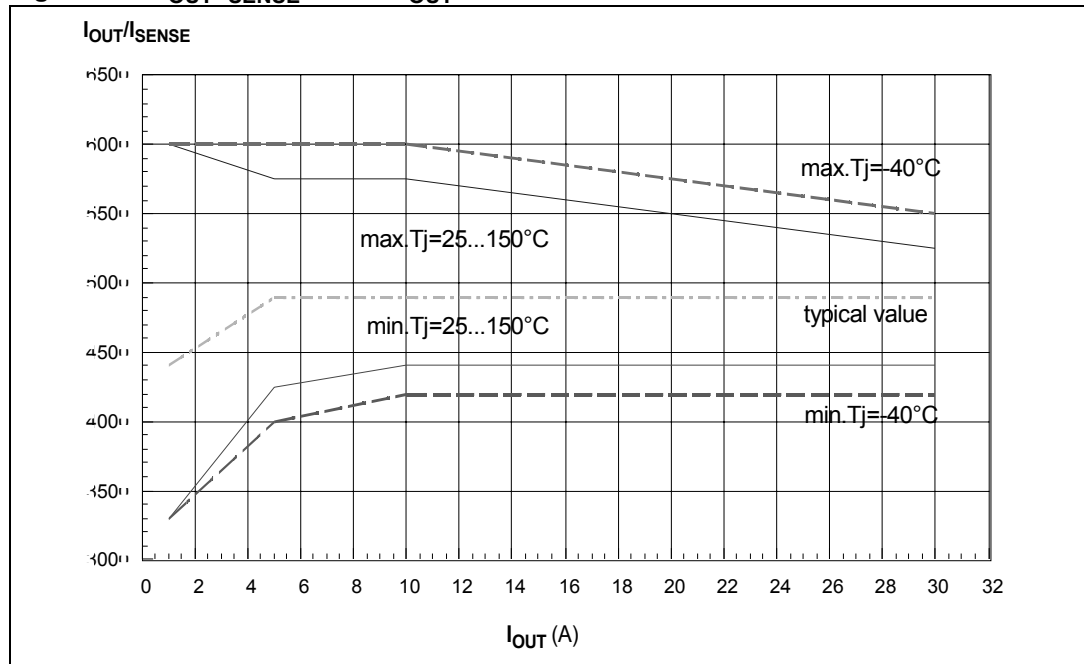
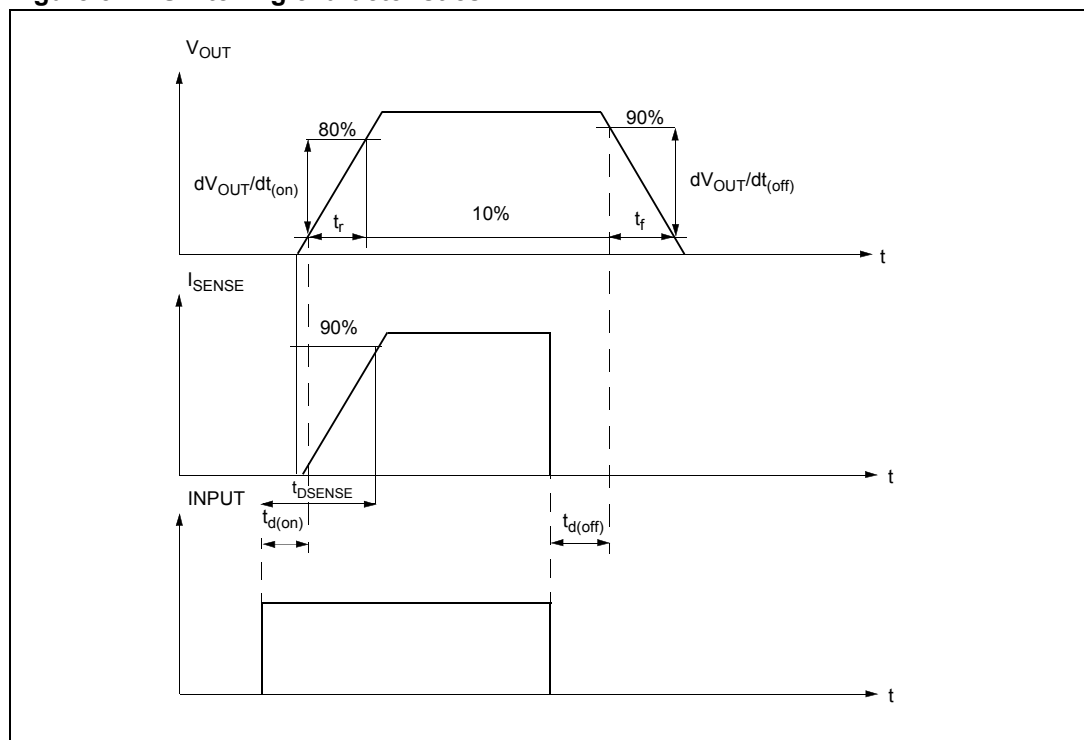

Figure 5. Switching characteristics



**Table 11. Truth table**

Conditions	Input	Output	Sense
Normal operation	L	L	0
	H	H	Nominal
Over temperature	L	L	0
	H	L	$V_{SENSEH}$
Undervoltage	L	L	0
	H	L	0
Overvoltage	L	L	0
	H	L	0
Short circuit to GND	L	L	0
	H	L	$(T_j < T_{TSD}) 0$
	H	L	$(T_j > T_{TSD}) V_{SENSEH}$
Short circuit to $V_{CC}$	L	H	0
	H	H	< Nominal
Negative output voltage clamp	L	L	0

**Table 12. Electrical transient requirements (part 1/3)**

ISO T/R 7637/1 Test pulse	Test level				Delays and impedance
	I	II	III	IV	
1	- 25V	- 50V	- 75V	- 100V	2ms, 10 $\Omega$
2	+ 25V	+ 50V	+ 75V	+ 100V	0.2ms, 10 $\Omega$
3a	- 25V	- 50V	- 100V	- 150V	0.1 $\mu$ s, 50 $\Omega$
3b	+ 25V	+ 50V	+ 75V	+ 100V	0.1 $\mu$ s, 50 $\Omega$
4	- 4V	- 5V	- 6V	- 7V	100ms, 0.01 $\Omega$
5	+ 26.5V	+ 46.5V	+ 66.5V	+ 86.5V	400ms, 2 $\Omega$

**Table 13. Electrical transient requirements (part 2/3)**

ISO 7637-2: 2004(E) Test pulse	Test level results			
	I	II	III	IV
1	C	C	C	C
2	C	C	C	C
3a	C	C	C	C
3b	C	C	C	C
4	C	C	C	C
5	C	E	E	E

**Table 14. Electrical transient requirements (part 3/3)**

Class	Contents
C	All functions of the device are performed as designed after exposure to disturbance.
E	One or more functions of the device are not performed as designed after exposure to disturbance and cannot be returned to proper operation without replacing the device.

Figure 6. Waveforms

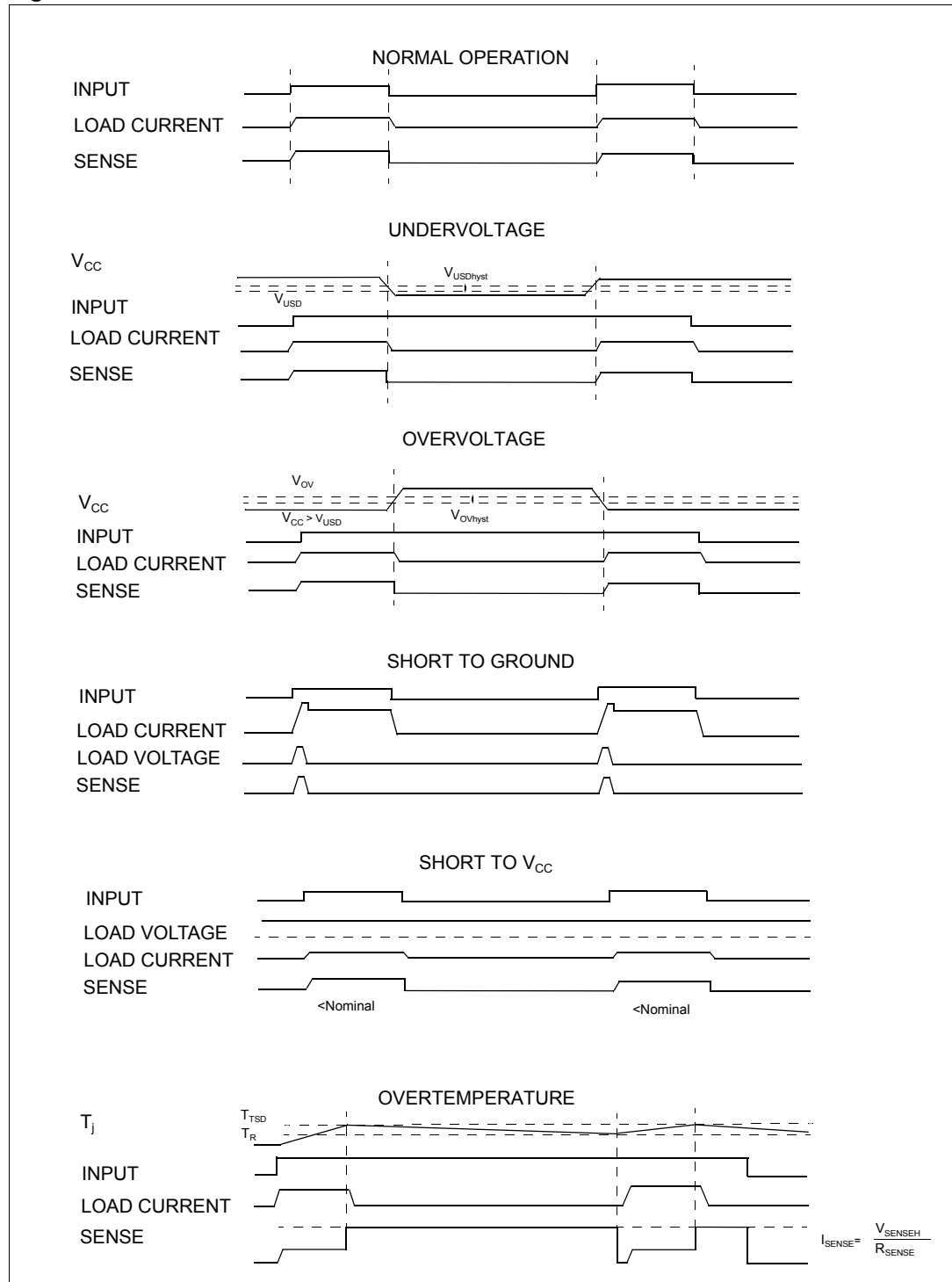

## 2.4 Electrical characteristics curves

Figure 7. Off-state output current

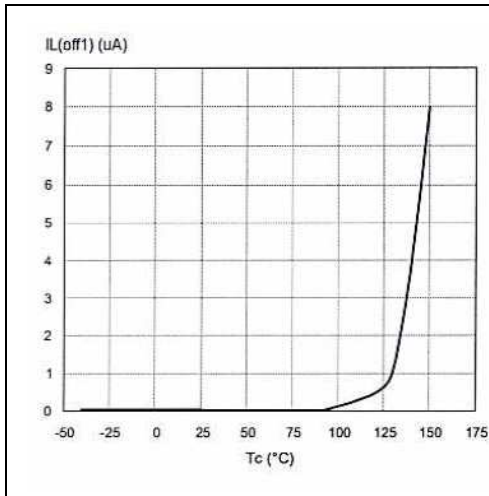

Figure 8. High level input current

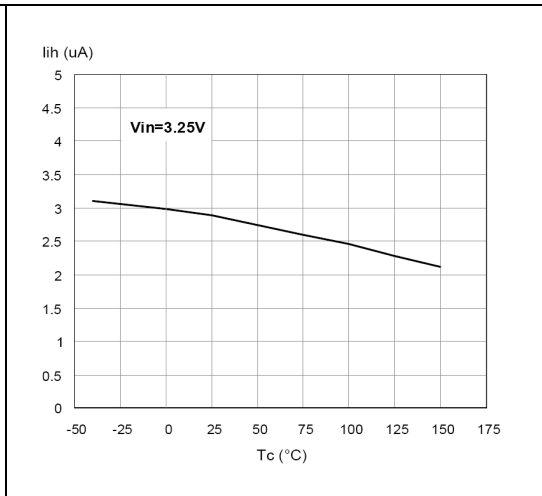

Figure 9. Input clamp voltage

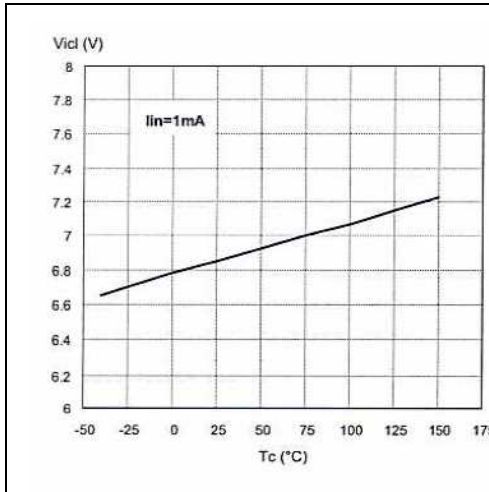

Figure 10. On-state resistance vs  $V_{CC}$

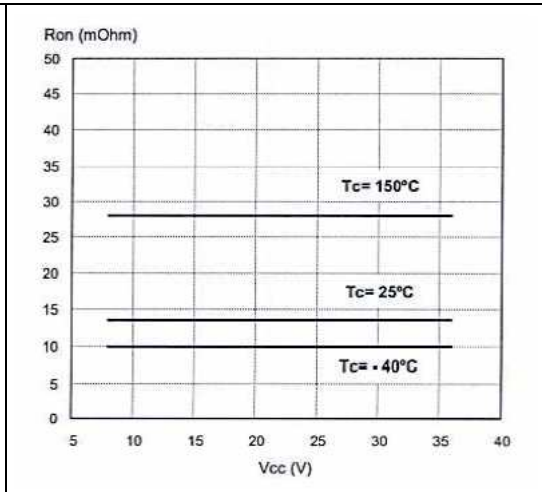

Figure 11. On-state resistance vs  $T_{CASE}$

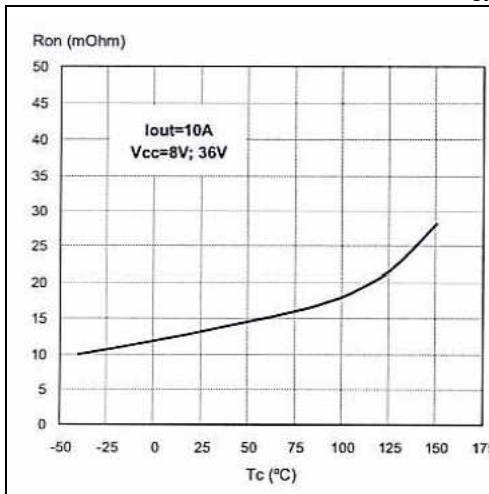

Figure 12. Input high level voltage

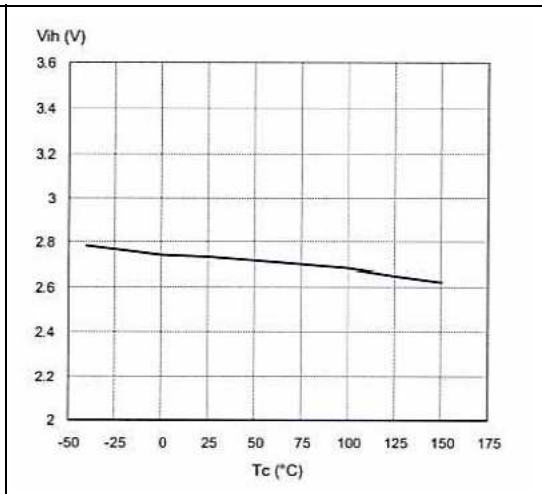

Figure 13. Input low level voltage

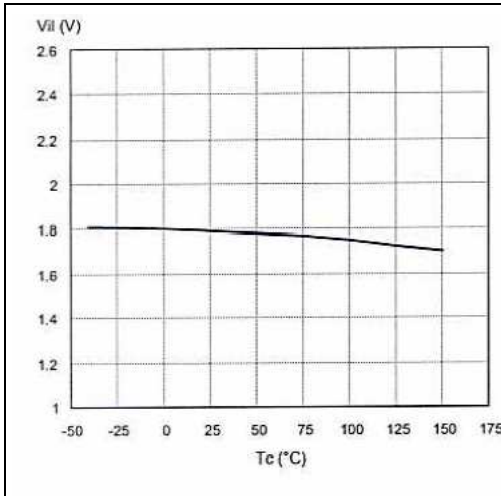

Figure 14. Input hysteresis voltage

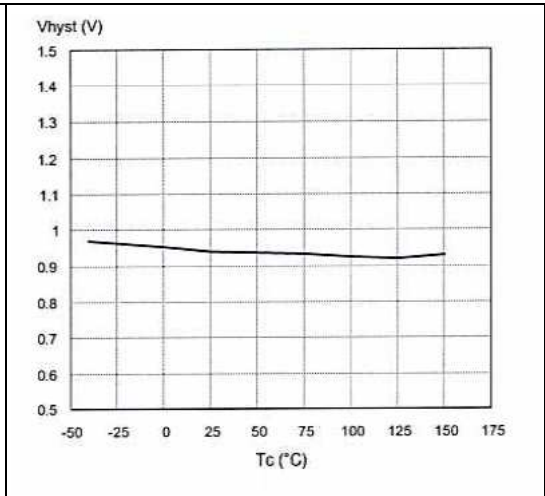

Figure 15. Turn-on voltage slope

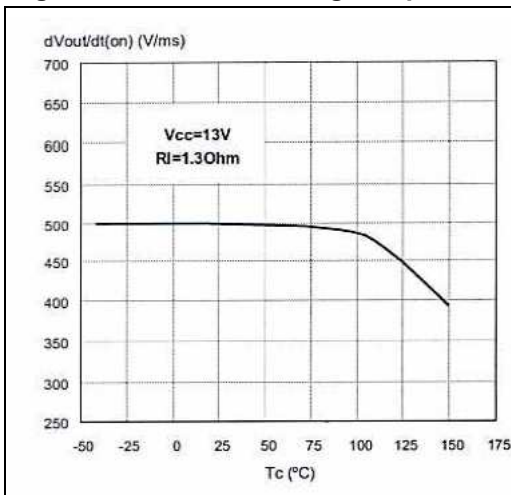

Figure 16. Turn-off voltage slope

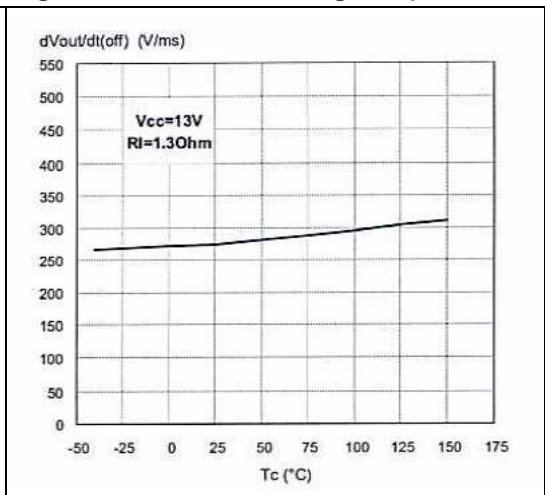

Figure 17. Overvoltage shutdown

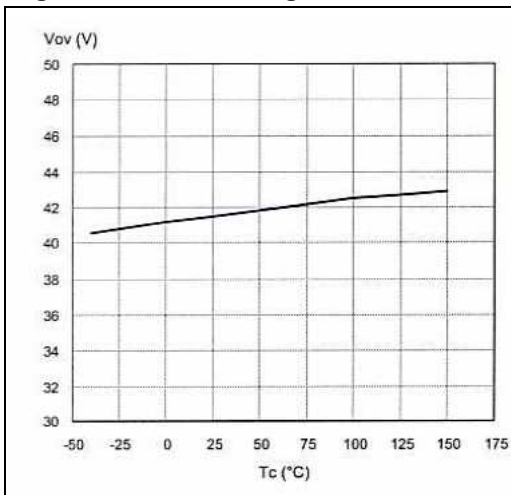
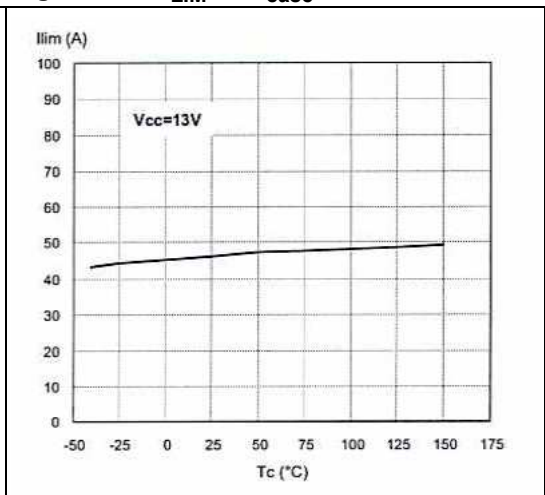
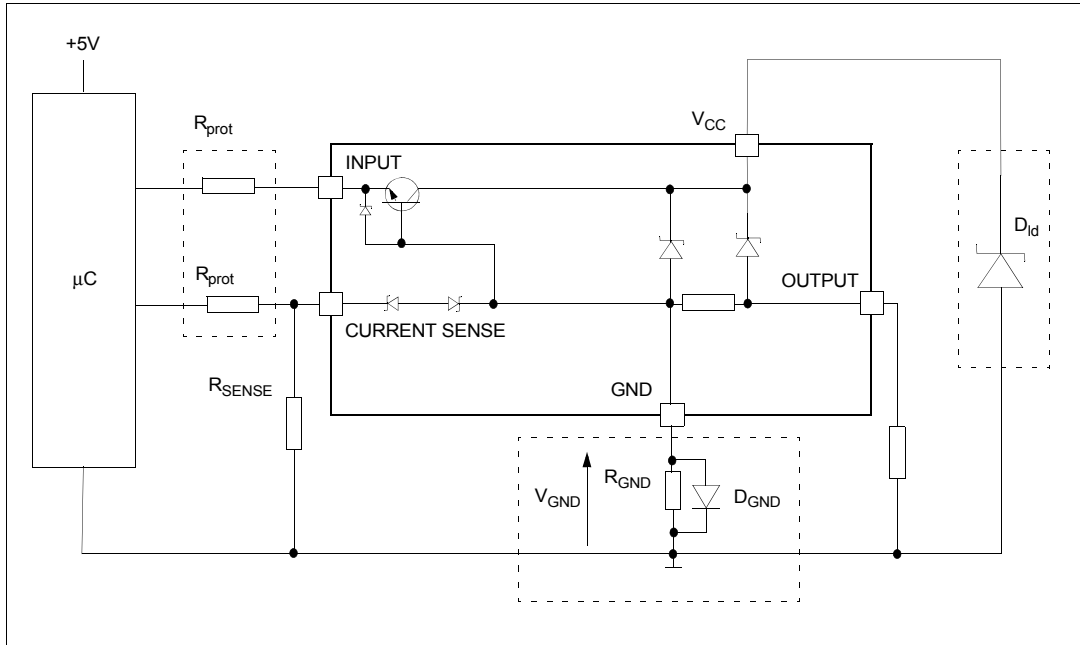

Figure 18.  $I_{LIM}$  vs  $T_{case}$



### 3 Application information

Figure 19. Application schematic



#### 3.1 GND protection network against reverse battery

##### 3.1.1 Solution 1: resistor in the ground line (R<sub>GND</sub> only)

This can be used with any type of load.

The following is an indication on how to dimension the R<sub>GND</sub> resistor.

1.  $R_{GND} \leq 600\text{mV} / (I_{S(on)max})$ .
2.  $R_{GND} \geq (-V_{CC}) / (-I_{GND})$

where  $-I_{GND}$  is the DC reverse ground pin current and can be found in the absolute maximum rating section of the device datasheet.

Power Dissipation in R<sub>GND</sub> (when V<sub>CC</sub> < 0: during reverse battery situations) is:

$$P_D = (-V_{CC})^2 / R_{GND}$$

This resistor can be shared amongst several different HSDs. Please note that the value of this resistor should be calculated with formula (1) where I<sub>S(on)max</sub> becomes the sum of the maximum on-state currents of the different devices.

Please note that if the microprocessor ground is not shared by the device ground then the R<sub>GND</sub> will produce a shift (I<sub>S(on)max</sub> \* R<sub>GND</sub>) in the input thresholds and the status output values. This shift will vary depending on how many devices are ON in the case of several high-side drivers sharing the same R<sub>GND</sub>.

If the calculated power dissipation leads to a large resistor or several devices have to share the same resistor then ST suggests to utilize Solution 2 (see below).

### 3.1.2 Solution 2: diode ( $D_{GND}$ ) in the ground line

A resistor ( $R_{GND} = 1k\Omega$ ) should be inserted in parallel to  $D_{GND}$  if the device drives an inductive load.

This small signal diode can be safely shared amongst several different HSDs. Also in this case, the presence of the ground network will produce a shift ( $\approx 600mV$ ) in the input threshold and in the status output values if the microprocessor ground is not common to the device ground. This shift will not vary if more than one HSD shares the same diode/resistor network.

Series resistor in INPUT lines is also required to prevent that, during battery voltage transient, the current exceeds the absolute maximum rating.

Safest configuration for unused INPUT pin is to leave it unconnected, while unused SENSE pin has to be connected to ground pin.

## 3.2 Load dump protection

$D_{ld}$  is necessary (voltage transient suppressor) if the load dump peak voltage exceeds the  $V_{CC}$  max DC rating. The same applies if the device is subject to transients on the  $V_{CC}$  line that are greater than the ones shown in the ISO T/R 7637/1 table.

## 3.3 MCU I/Os protection

If a ground protection network is used and negative transient are present on the  $V_{CC}$  line, the control pins will be pulled negative. ST suggests to insert a resistor ( $R_{prot}$ ) in line to prevent the  $\mu C$  I/Os pins to latch-up.

The value of these resistors is a compromise between the leakage current of  $\mu C$  and the current required by the HSD I/Os (Input levels compatibility) with the latch-up limit of  $\mu C$  I/Os.

$$-V_{CCpeak}/I_{latchup} \leq R_{prot} \leq (V_{OH\mu C} - V_{IH} - V_{GND}) / I_{IHmax}$$

Calculation example:

For  $V_{CCpeak} = -100V$  and  $I_{latchup} \geq 20mA$ ;  $V_{OH\mu C} \geq 4.5V$

$$5k\Omega \leq R_{prot} \leq 65k\Omega$$

Recommended values:  $R_{prot} = 10k\Omega$ .

## 4 Package and packing information

### 4.1 ECOPACK<sup>®</sup> packages

In order to meet environmental requirements, ST offers these devices in different grades of ECOPACK<sup>®</sup> packages, depending on their level of environmental compliance. ECOPACK<sup>®</sup> specifications, grade definitions and product status are available at: [www.st.com](http://www.st.com).

ECOPACK<sup>®</sup> is an ST trademark.

#### 4.1.1 PENTAWATT (vertical) mechanical data

Figure 20. PENTAWATT (vertical) package dimensions

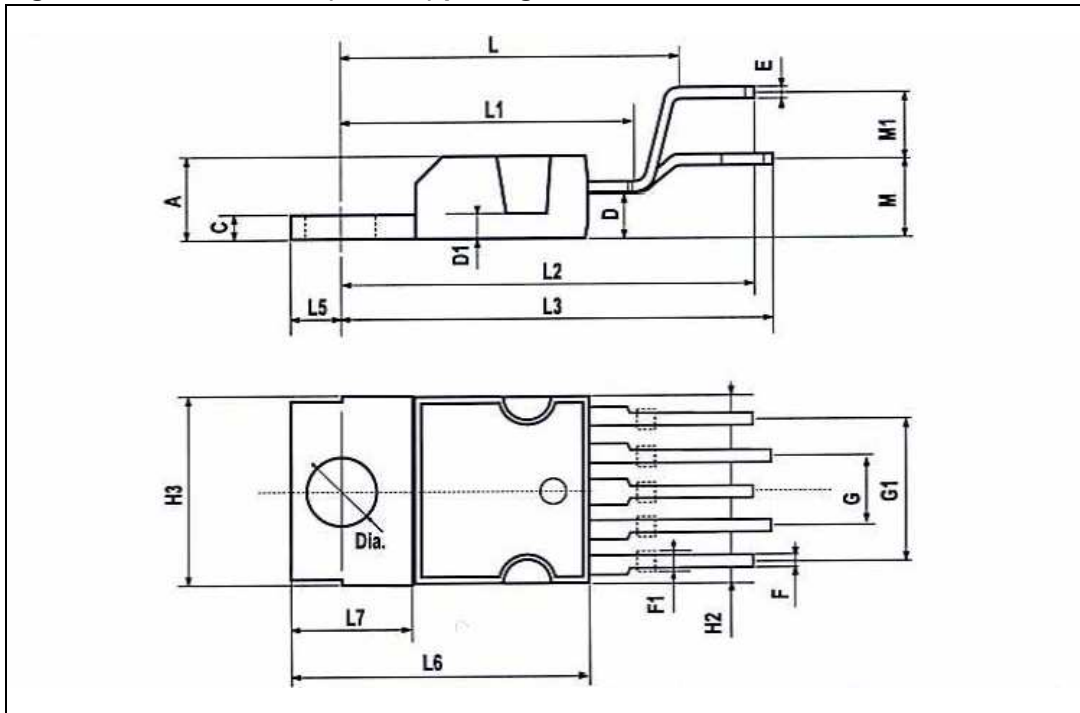

Table 15. PENTAWATT (vertical) mechanical data

Symbol	millimeters		
	Min	Typ	Max
A			4.8
C			1.37
D	2.4		2.8
D1	1.2		1.35
E	0.35		0.55
F	0.8		1.05

Table 15. PENTAWATT (vertical) mechanical data (continued)

Symbol	millimeters		
	Min	Typ	Max
F1	1		1.4
G	3.2	3.4	3.6
G1	6.6	6.8	7
H2			10.4
H3	10.05		10.4
L		17.85	
L1		15.75	
L2		21.4	
L3		22.5	
L5	2.6		3
L6	15.1		15.8
L7	6		6.6
M		4.5	
M1		4	
Diam.	3.65		3.85

4.1.2 PENTAWATT (in-line) mechanical data

Figure 21. PENTAWATT (in-line) package dimensions

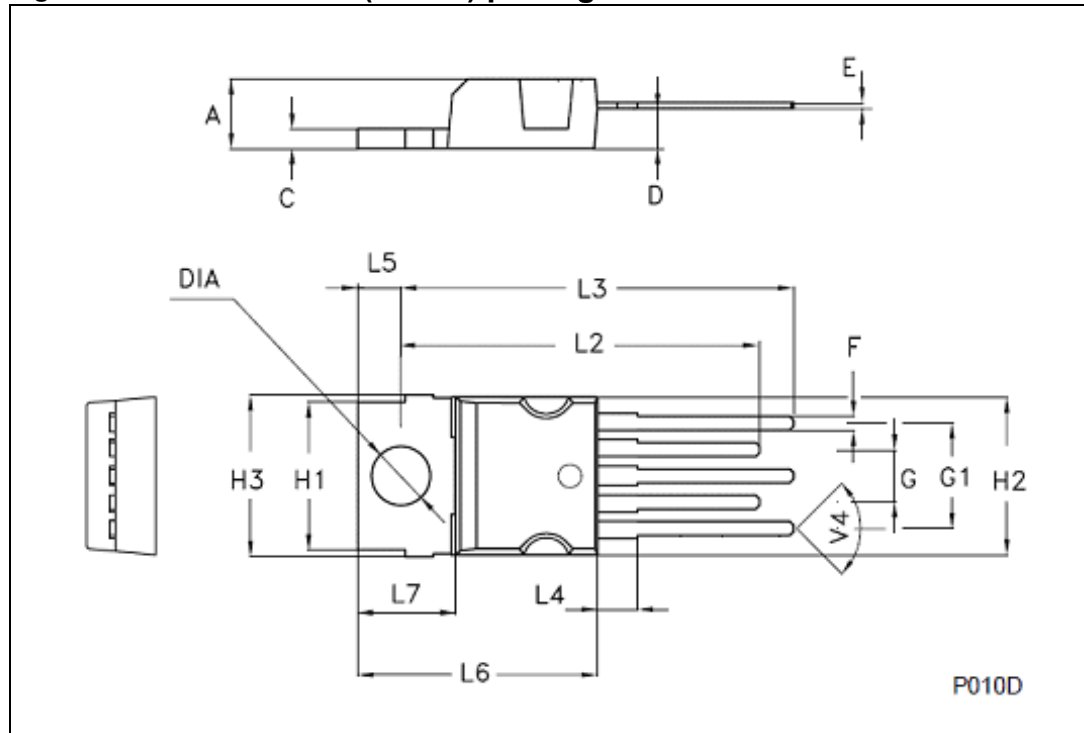

Table 16. PENTAWATT (in-line) mechanical data

Symbol	millimeters		
	Min	Typ	Max
A	4.3		4.8
C	1.17		1.37
D	2.4		2.8
E	0.35		0.55
F	0.8		1.05
F2	1.1		1.4
F3	1.25		1.55
G	3.2		3.6
G1	6.6		7
H1	9.3		9.7
H2			10.4
H3	10.05		10.4
L2	23.05		23.8
L3	25.3		

Table 16. PENTAWATT (in-line) mechanical data (continued)

Symbol	millimeters		
	Min	Typ	Max
L4	0.9		2.9
L5	2.6		3
L6	15.1		15.8
L7	6		6.6
V4		90°	
Diam.	3.65		3.85

## 4.2 PENTAWATT packing information

Figure 22. PENTAWATT tube shipment (no suffix)

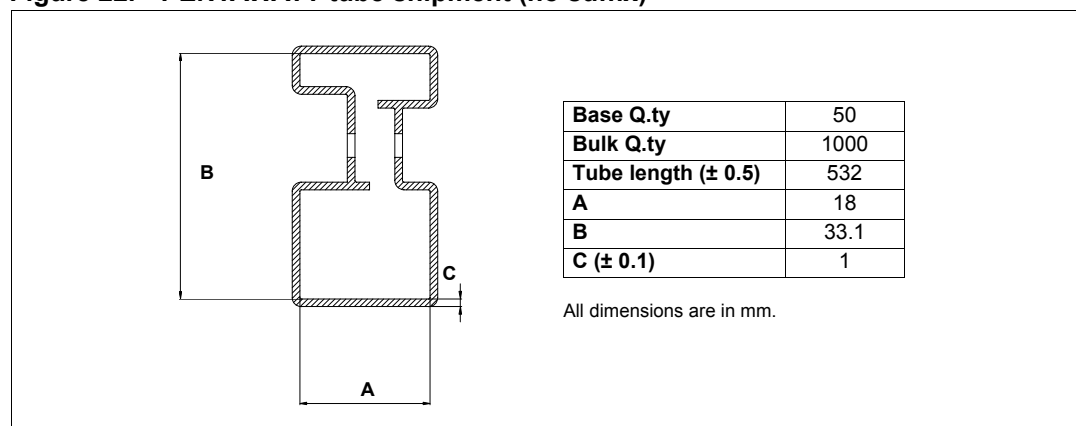

## 5 Revision history

Table 17. Document revision history

Date	Revision	Changes
22-Oct-2004	1	Initial release.
22-Sep-2009	2	Removed all the references to VN920B5-E and VN920SO-E
08-Oct-2009	3	Added PENTAWATT in-line package: – Updated <a href="#">Table 1: Device summary</a> . – Added <a href="#">Section 4.1.2: PENTAWATT (in-line) mechanical data</a> .

**Please Read Carefully:**

Information in this document is provided solely in connection with ST products. STMicroelectronics NV and its subsidiaries ("ST") reserve the right to make changes, corrections, modifications or improvements, to this document, and the products and services described herein at any time, without notice.

All ST products are sold pursuant to ST's terms and conditions of sale.

Purchasers are solely responsible for the choice, selection and use of the ST products and services described herein, and ST assumes no liability whatsoever relating to the choice, selection or use of the ST products and services described herein.

No license, express or implied, by estoppel or otherwise, to any intellectual property rights is granted under this document. If any part of this document refers to any third party products or services it shall not be deemed a license grant by ST for the use of such third party products or services, or any intellectual property contained therein or considered as a warranty covering the use in any manner whatsoever of such third party products or services or any intellectual property contained therein.

**UNLESS OTHERWISE SET FORTH IN ST'S TERMS AND CONDITIONS OF SALE ST DISCLAIMS ANY EXPRESS OR IMPLIED WARRANTY WITH RESPECT TO THE USE AND/OR SALE OF ST PRODUCTS INCLUDING WITHOUT LIMITATION IMPLIED WARRANTIES OF MERCHANTABILITY, FITNESS FOR A PARTICULAR PURPOSE (AND THEIR EQUIVALENTS UNDER THE LAWS OF ANY JURISDICTION), OR INFRINGEMENT OF ANY PATENT, COPYRIGHT OR OTHER INTELLECTUAL PROPERTY RIGHT.**

**UNLESS EXPRESSLY APPROVED IN WRITING BY AN AUTHORIZED ST REPRESENTATIVE, ST PRODUCTS ARE NOT RECOMMENDED, AUTHORIZED OR WARRANTED FOR USE IN MILITARY, AIR CRAFT, SPACE, LIFE SAVING, OR LIFE SUSTAINING APPLICATIONS, NOR IN PRODUCTS OR SYSTEMS WHERE FAILURE OR MALFUNCTION MAY RESULT IN PERSONAL INJURY, DEATH, OR SEVERE PROPERTY OR ENVIRONMENTAL DAMAGE. ST PRODUCTS WHICH ARE NOT SPECIFIED AS "AUTOMOTIVE GRADE" MAY ONLY BE USED IN AUTOMOTIVE APPLICATIONS AT USER'S OWN RISK.**

Resale of ST products with provisions different from the statements and/or technical features set forth in this document shall immediately void any warranty granted by ST for the ST product or service described herein and shall not create or extend in any manner whatsoever, any liability of ST.

ST and the ST logo are trademarks or registered trademarks of ST in various countries.

Information in this document supersedes and replaces all information previously supplied.

The ST logo is a registered trademark of STMicroelectronics. All other names are the property of their respective owners.

© 2009 STMicroelectronics - All rights reserved

STMicroelectronics group of companies

Australia - Belgium - Brazil - Canada - China - Czech Republic - Finland - France - Germany - Hong Kong - India - Israel - Italy - Japan - Malaysia - Malta - Morocco - Philippines - Singapore - Spain - Sweden - Switzerland - United Kingdom - United States of America

[www.st.com](http://www.st.com)

