

Single chip RDS demodulator

Features

- Very high RDS demodulation quality with improved digital signal processing
- High performance, 57 kHz bandpass filter (8th order)
- Filter adjustment free and without external components
- Purely digital RDS demodulation without external components
- RDS signal quality output
- 4.332 MHz crystal oscillator (8.664 MHz optional)
- Low noise CMOS technology
- Low radiation

Description

The TDA7478 recovers the additional inaudible RDS information which is transmitted by FM radio broadcasting stations and operates in accordance with the EBU (European Broadcasting Union) specifications.

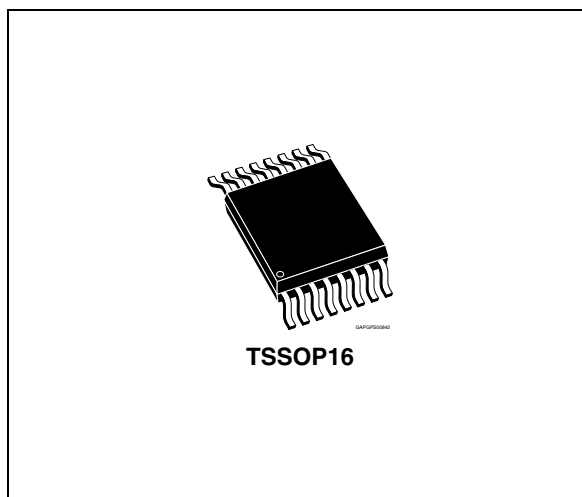

The device is made up of two sections: a cascaded antialiasing + switched capacitors 8th bandpass filter for precise RDS band selection and a demodulating section that performs the extraction of RDS data stream (RDDA) and clock (RDCL), to be further processed by a suitable RDS decoder.

Output for RDS signal quality is also present.

Table 1. Device summary

Order code	Package	Packing
E-TDA7478AD	TSSOP16	Tube
E-TDA7478ADTR		Tape and reel

Contents

- 1 Block diagram and pins description 3**
 - 1.1 Block diagram 3
 - 1.2 Pins description 4

- 2 Electrical specifications 5**
 - 2.1 Thermal data 5
 - 2.2 Absolute maximum ratings 5
 - 2.3 Electrical characteristics 5

- 3 Output timing 7**

- 4 Oscillator controls (FSEL, OSEL) 8**

- 5 Package information 9**

- 6 Revision history 10**

1 Block diagram and pins description

1.1 Block diagram

Figure 1. Block diagram

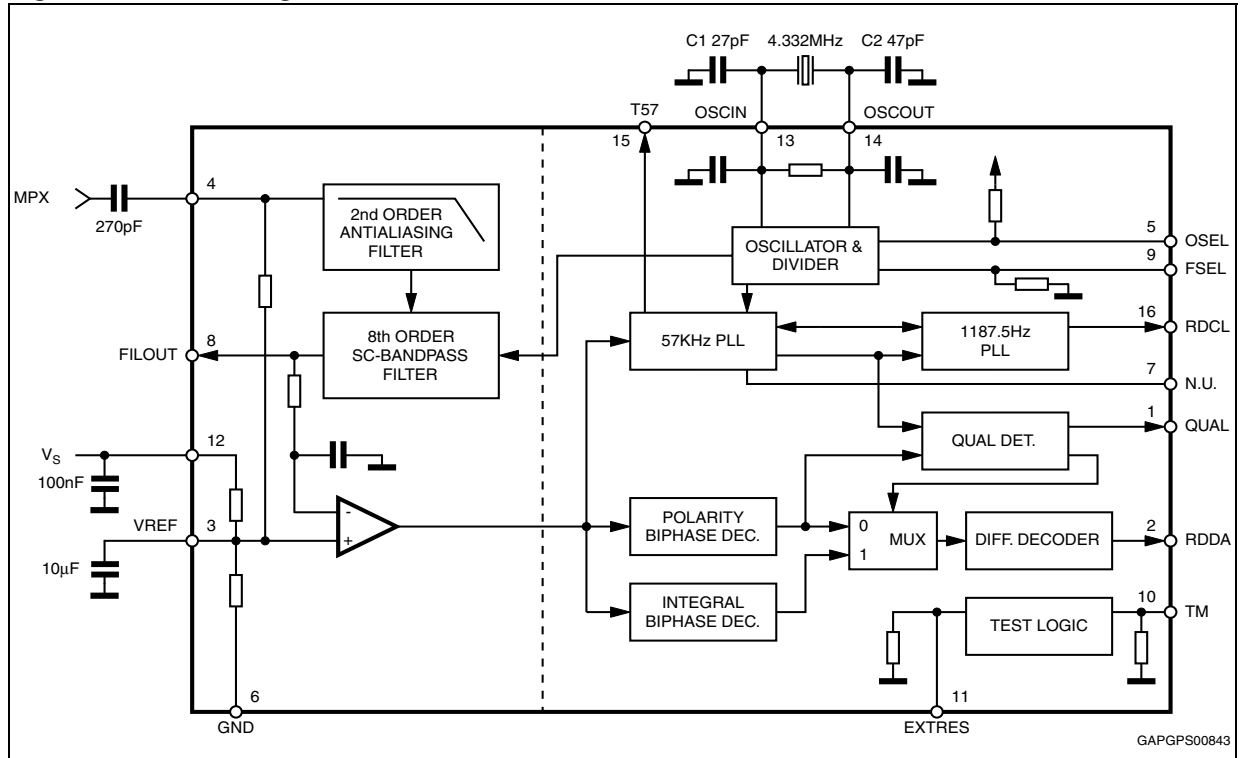

1.2 Pins description

Figure 2. Pin connection (top view)

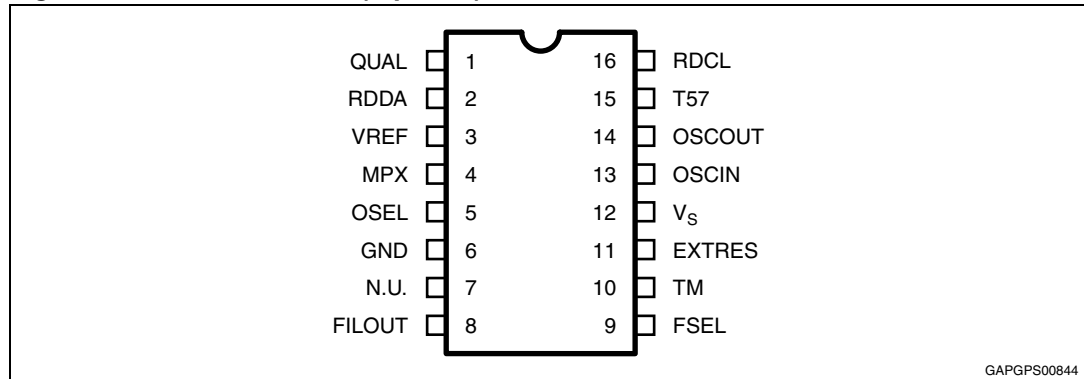

Table 2. Pins description

Pin #	Name	Description
1	QUAL	Output for signal quality indication (High = good)
2	RDDA	RDS data output
3	VREF	Reference voltage
4	MPX	RDS input signal
5	OSEL	Oscillator selector pin: – open, closed to VS = quartz oscillator – closed to GND = external driven
6	GND	Ground
7	N.U.	Not Used (to be left open)
8	FILOUT	Filter output
9	FSEL	Frequency selector pin: – open = 4.332 MHz – closed to VS = 8.664 MHz
10	TM	Test mode pin: – open = normal operation – closed to VS = testmode
11	EXTRES	Reset pin: – open = run mode – closed to VS = reset condition
12	VS	Supply voltage
13	OSCIN	Oscillator input
14	OSCOUT	Oscillator output
15	T57	Testing output pin: 57 kHz clock output
16	RDCL	RDS clock output 1187.5 Hz

2 Electrical specifications

2.1 Thermal data

Table 3. Thermal data

Symbol	Description	Value	Unit
$R_{th\ j-case}$	Thermal resistance junction-to-case	Max. 200	$^{\circ}C/W$

2.2 Absolute maximum ratings

Table 4. Absolute maximum ratings

Symbol	Parameter	Value	Unit
V_S	Supply voltage	-0.3 to 7	V
T_{op}	Operating temperature range	-40 to 85	$^{\circ}C$
T_{stg}	Storage temperature	-55 to 150	$^{\circ}C$

2.3 Electrical characteristics

$T_{amb} = 25^{\circ}C$, $V_S = 5V$, unless otherwise specified.

Table 5. Electrical characteristics

Symbol	Parameter	Test condition	Min.	Typ.	Max.	Unit
V_S	Supply voltage	-	4.5	5	5.5	V
I_S	Supply current	-	-	7.5	12.0	mA
Filter						
f_C	Center frequency	-	56.6	57	57.4	kHz
BW	3 dB bandwidth	-	2.5	3	3.5	kHz
G	Gain	$f = 57\text{ kHz}$	17	20	23	dB
A	Attenuation	$\Delta f \pm 4\text{ kHz}$	-	22	-	dB
		$f = 38\text{ kHz}$	-	60	-	dB
		$f = 67\text{ kHz}$	-	45	-	dB
R_I	Input impedance of MPX	-	-	120	-	$K\Omega$
R_L	Load impedance on FILOUT	-	1	-	-	$M\Omega$
S/N	Signal to noise ratio	$V_{IN} = 3\text{ mVRMS}$	30	40	-	dB
V_{IN}	MPX input signal	$f = 19\text{ kHz}; T_3 \leq 40\text{ dB}^{(1)}$ $f = 57\text{ kHz (RDS)}$	-	-	1000 50	mV_{RMS} mV_{RMS}
S_{RDS}	RDS detection sensitivity	-	1	-	-	mV_{rms}

Table 5. Electrical characteristics (continued)

Symbol	Parameter	Test condition	Min.	Typ.	Max.	Unit
S_{ARI}	ARI detection sensitivity	-	3	-	-	mVrms
V_{REF}	Reference	-	-	$V_S/2$	-	V
Demodulator						
Input pins (EXTRES, FSEL, TM) all with internal pull down resistor						
Input pin (OSEL) with internal pull up resistor						
I_{PD}	Input current	$V_{IN} = 5\text{ V}$ (pull-down input)	15	-	30	μA
I_{PU}	Input current	$V_{IN} = 0\text{ V}$ (pull-up input)	-25	-	-10	μA
V_{IH}	Input voltage high	-	$0.7 \cdot V_S$	$0.8 \cdot V_S$	-	V
V_{IL}	Input voltage low	-	-	$0.2 \cdot V_S$	$0.3 \cdot V_S$	V
Output pins (RDCL, RDDA, QUAL, T57)						
V_{OH}	Output voltage high	$I_L = 0.5\text{ mA}$	4	4.6	-	V
V_{OL}	Output voltage low	$I_L = 0.5\text{ mA}$	-	0.4	1	V
Oscillator						
V_{CLL}	Input level OSCIN pin	OSEL = open circuit	-	-	1	V
V_{CLH}	Input level OSCIN pin	OSEL = open circuit	4	-	-	V
	Amplitude OSCOUT	OSEL = open circuit	-	4.5	-	V
V_{PP}	Amplitude OSCIN (for external drive)	OSEL = GND, $f = 4.332\text{ MHz}$	-	100	-	mVpp
		OSEL = GND, $f = 8.664\text{ MHz}$	-	120	-	mVpp

1. The 3rd harmonic (57 kHz) must be less than -40 dB with respect to the input signal plus gain.

3 Output timing

The RDS (1187.5Hz) output clock on RDCL line is synchronized to the incoming data. According to the internal PLL lock condition data change can result on the falling or on the rising clock edge. (see [Figure 3](#)). Whichever clock edge is used by the decoder (rising or falling edge) the data will remain valid for 416.7 μ s after the clock transition.

Figure 3. RDS timing diagram

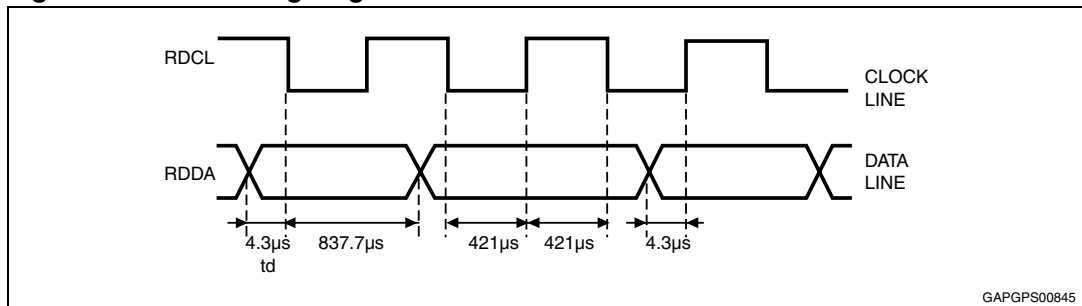

4 Oscillator controls (FSEL, OSEL)

Two different crystal frequencies can be used. The adaption of the internal clock divider to the external crystal is achieved via the input pin FSEL. See the following table for reference.

Table 6. Crystal frequencies

Crystal	FSEL (pin configuration)
4.332MHz	connected to GND or open
8.664MHz	connected to Vs

A special mode is introduced to reduce EMI. With pin OSEL connected to GND the internal oscillator is switched off and an external sinusoidal frequency could be applied on OSCIN. The peak to peak voltage of this signal can be reduced down to 60 mV.

In this mode the frequency selection via FSEL is still active.

Suggested values of C1 and C2 are shown in the following table.

Table 7. C1 and C2 suggested value

Crystal	C1	C2
4.332MHz	27pF	47pF
8.664MHz	27pF	-

5 Package information

In order to meet environmental requirements, ST offers these devices in different grades of ECOPACK® packages, depending on their level of environmental compliance. ECOPACK® specifications, grade definitions and product status are available at: www.st.com.

ECOPACK® is an ST trademark.

Figure 4. TSSOP16 mechanical data and package dimensions

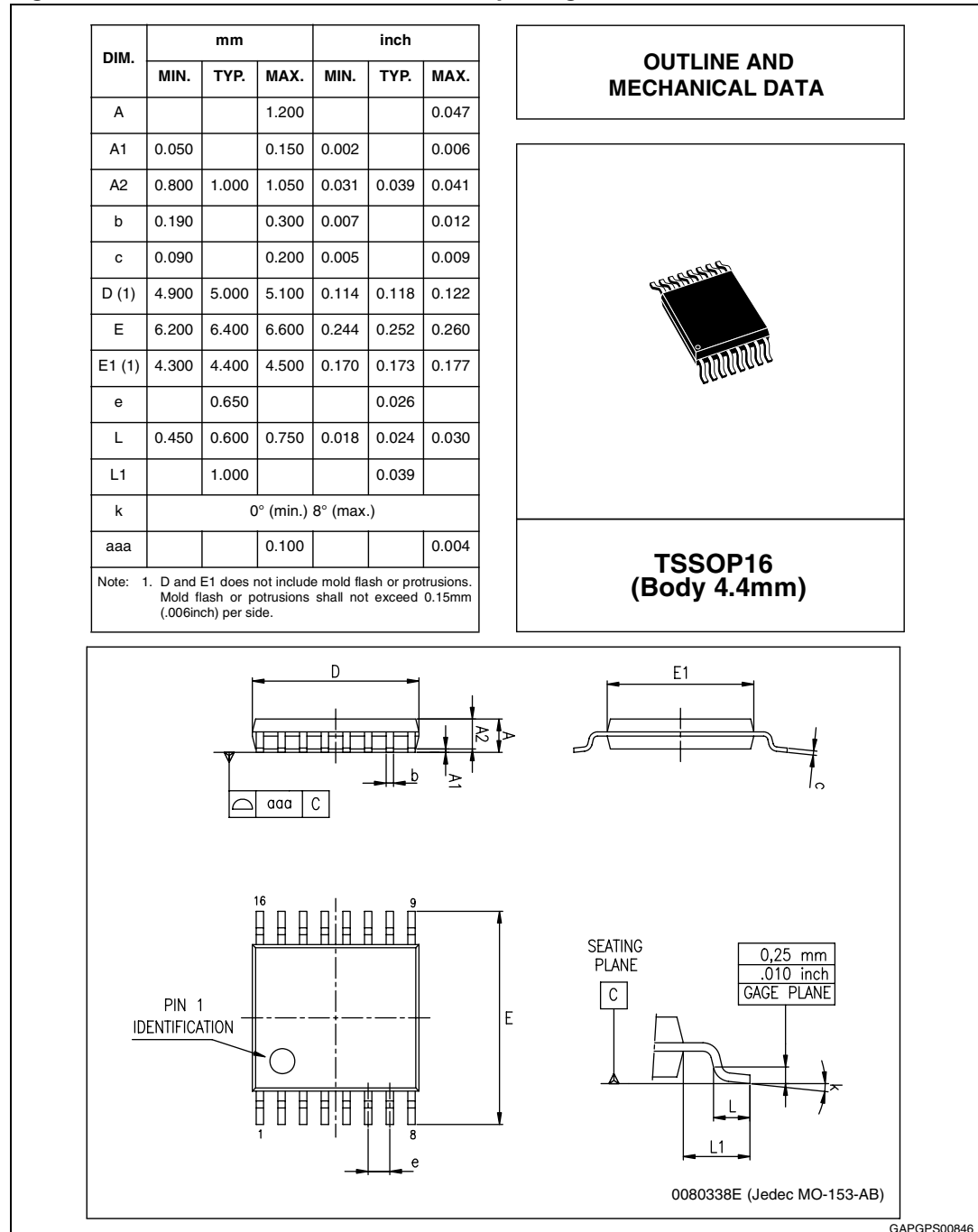

6 Revision history

Table 8. Document revision history

Date	Revision	Changes
09-Jul-2004	1	Initial release.
14-Nov-2004	2	Add in the Table 5 "RDS and ARI Detection Sensitivity" parameters.
30-Jun-2011	3	Document reformatted. Updated order code in Table 1: Device summary on page 1 .

Please Read Carefully:

Information in this document is provided solely in connection with ST products. STMicroelectronics NV and its subsidiaries ("ST") reserve the right to make changes, corrections, modifications or improvements, to this document, and the products and services described herein at any time, without notice.

All ST products are sold pursuant to ST's terms and conditions of sale.

Purchasers are solely responsible for the choice, selection and use of the ST products and services described herein, and ST assumes no liability whatsoever relating to the choice, selection or use of the ST products and services described herein.

No license, express or implied, by estoppel or otherwise, to any intellectual property rights is granted under this document. If any part of this document refers to any third party products or services it shall not be deemed a license grant by ST for the use of such third party products or services, or any intellectual property contained therein or considered as a warranty covering the use in any manner whatsoever of such third party products or services or any intellectual property contained therein.

UNLESS OTHERWISE SET FORTH IN ST'S TERMS AND CONDITIONS OF SALE ST DISCLAIMS ANY EXPRESS OR IMPLIED WARRANTY WITH RESPECT TO THE USE AND/OR SALE OF ST PRODUCTS INCLUDING WITHOUT LIMITATION IMPLIED WARRANTIES OF MERCHANTABILITY, FITNESS FOR A PARTICULAR PURPOSE (AND THEIR EQUIVALENTS UNDER THE LAWS OF ANY JURISDICTION), OR INFRINGEMENT OF ANY PATENT, COPYRIGHT OR OTHER INTELLECTUAL PROPERTY RIGHT.

UNLESS EXPRESSLY APPROVED IN WRITING BY AN AUTHORIZED ST REPRESENTATIVE, ST PRODUCTS ARE NOT RECOMMENDED, AUTHORIZED OR WARRANTED FOR USE IN MILITARY, AIR CRAFT, SPACE, LIFE SAVING, OR LIFE SUSTAINING APPLICATIONS, NOR IN PRODUCTS OR SYSTEMS WHERE FAILURE OR MALFUNCTION MAY RESULT IN PERSONAL INJURY, DEATH, OR SEVERE PROPERTY OR ENVIRONMENTAL DAMAGE. ST PRODUCTS WHICH ARE NOT SPECIFIED AS "AUTOMOTIVE GRADE" MAY ONLY BE USED IN AUTOMOTIVE APPLICATIONS AT USER'S OWN RISK.

Resale of ST products with provisions different from the statements and/or technical features set forth in this document shall immediately void any warranty granted by ST for the ST product or service described herein and shall not create or extend in any manner whatsoever, any liability of ST.

ST and the ST logo are trademarks or registered trademarks of ST in various countries.

Information in this document supersedes and replaces all information previously supplied.

The ST logo is a registered trademark of STMicroelectronics. All other names are the property of their respective owners.

© 2011 STMicroelectronics - All rights reserved

STMicroelectronics group of companies

Australia - Belgium - Brazil - Canada - China - Czech Republic - Finland - France - Germany - Hong Kong - India - Israel - Italy - Japan - Malaysia - Malta - Morocco - Philippines - Singapore - Spain - Sweden - Switzerland - United Kingdom - United States of America

www.st.com

