

Quad channel high-side driver

Features

Max supply voltage	V_{CC}	41V
Operating voltage range	V_{CC}	5.5 to 36V
Max on-state resistance	R_{ON}	500m Ω
Current limitation (typ)	I_{LIM}	0.4A
Off-state supply current	I_S	25 μ A

- CMOS compatible I/O's
- Chip Enable
- Junction over temperature protection and diagnostic
- Current limitation
- Shorted load protection
- Undervoltage shutdown
- Protection against loss of ground
- Very low standby current
- In compliance with the 2002/95/EC european directive

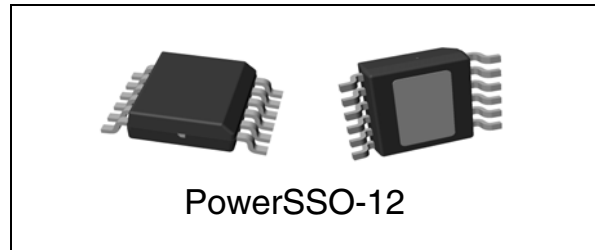

Description

The VNQ500 is a monolithic device designed in STMicroelectronics VIPower M0-3 technology, intended for driving any kind of load with one side connected to ground.

Active current limitation, combined with latched thermal shutdown, protect the device against overload.

In the case of over temperature of one channel the relative I/O pin is pulled down.

The device automatically turns off in the case of ground pin disconnection.

Table 1. Device summary

Package	Order codes	
	Tube	Tape and reel
PowerSSO-12	VNQ500PEP-E	VNQ500PEPTR-E

Contents

1	Block diagram and pin description	5
2	Electrical specifications	7
2.1	Absolute maximum ratings	7
2.2	Thermal data	7
2.3	Electrical characteristics	8
2.4	Electrical characteristics curves	12
3	Application information	14
3.1	GND protection network against reverse battery	14
3.1.1	Solution 1: a resistor in the ground line (RGND only)	14
3.1.2	Solution 2: a diode (D_{GND}) in the ground line	15
3.2	Load dump protection	15
3.3	MCU I/O protection	15
3.4	Maximum demagnetization energy ($V_{CC} = 13.5V$)	16
4	Package and thermal data	17
4.1	PowerSSO-12 thermal data	17
5	Package and packing information	20
5.1	ECOPACK [®] packages	20
5.2	PowerSSO-12 mechanical data	20
5.3	PowerSSO-12 packing information	22
6	Revision history	23

List of tables

Table 1.	Device summary	1
Table 2.	Pin definitions and functions	5
Table 3.	Absolute maximum ratings	7
Table 4.	Thermal data	7
Table 5.	Power	8
Table 6.	Switching ($V_{CC} = 13V$)	9
Table 7.	Input and CE pin	9
Table 8.	Protections and diagnostics	9
Table 9.	Truth table	10
Table 10.	Electrical transient requirements on VCC pin	11
Table 11.	Thermal parameter	19
Table 12.	PowerSSO-12 mechanical data	20
Table 13.	Document revision history	23

List of figures

Figure 1.	Block diagram	5
Figure 2.	Configuration diagram (top view)	6
Figure 3.	Current and voltage conventions	8
Figure 4.	Switching time waveforms: turn-on and turn-off	10
Figure 5.	Driving circuit	10
Figure 6.	Waveforms	11
Figure 7.	Off-state output current.	12
Figure 8.	High level input current.	12
Figure 9.	Input clamp voltage.	12
Figure 10.	Turn-off voltage slope.	12
Figure 11.	Overvoltage shutdown	12
Figure 12.	Turn-off voltage slope.	12
Figure 13.	ILIM vs Tcase	13
Figure 14.	On-state resistance vs VCC	13
Figure 15.	Input high level	13
Figure 16.	Input hysteresis voltage	13
Figure 17.	On-state resistance vs Tcase	13
Figure 18.	Input low level.	13
Figure 19.	Application schematic.	14
Figure 20.	Maximum turn-off current versus load inductance	16
Figure 21.	PowerSSO-12 PC board.	17
Figure 22.	Rthj-amb Vs PCB copper area in open box free air condition	17
Figure 23.	Thermal impedance junction ambient single pulse.	18
Figure 24.	Thermal fitting model of a quad channel HSD in PowerSSO-12	18
Figure 25.	PowerSSO-12 package dimensions	21
Figure 26.	PowerSSO-12 tube shipment (no suffix)	22
Figure 27.	PowerSSO-12 tape and reel shipment (suffix "TR")	22

1 Block diagram and pin description

Figure 1. Block diagram

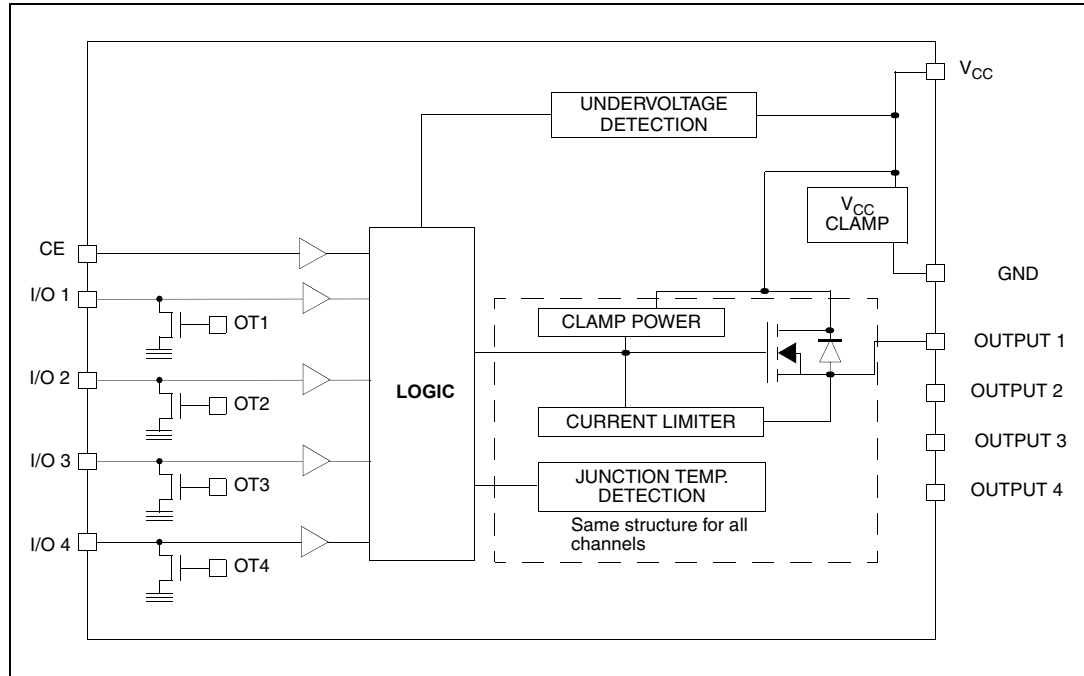
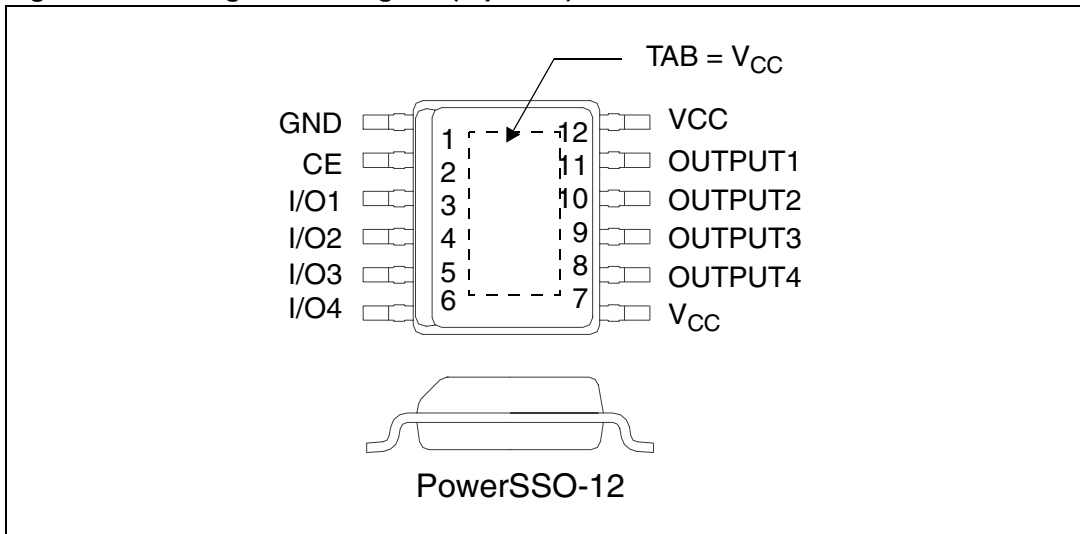

Table 2. Pin definitions and functions

Pin No	Symbol	Function
TAB	V _{CC}	Positive power supply voltage
7,12	V _{CC}	Positive power supply voltage
1	GND	Logic ground
2	CE	Chip Enable
3	I/O 1	Input/output of channel 1
4	I/O 2	Input/output of channel 2
5	I/O 3	Input/output of channel 3
6	I/O 4	Input/output of channel 4
8	OUTPUT 4	High-side output of channel 4
9	OUTPUT 3	High-side output of channel 3
10	OUTPUT 2	High-side output of channel 2
11	OUTPUT 1	High-side output of channel 1

Figure 2. Configuration diagram (top view)



2 Electrical specifications

2.1 Absolute maximum ratings

Stressing the device above the rating listed in the “Absolute maximum ratings” table may cause permanent damage to the device. These are stress ratings only and operation of the device at these or any other conditions above those indicated in the Operating sections of this specification is not implied. Exposure to Absolute Maximum Rating conditions for extended periods may affect device reliability. Refer also to the STMicroelectronics SURE Program and other relevant quality document.

Table 3. Absolute maximum ratings

Symbol	Parameter	Value	Unit
V_{CC}	DC supply voltage	41	V
$-V_{CC}$	Reverse supply voltage	-0.3	V
$-I_{GND}$	DC ground pin reverse current	- 250	mA
I_{OUT}	DC output current	Internally limited	A
$-I_{OUT}$	Reverse DC output current	-1	A
I_{IN}	DC Input current	+/- 10	mA
V_{ESD}	Electrostatic discharge (R = 1.5K Ω ; C = 100pF) - I/On - OUTn and V_{CC}	4000	V
		5000	V
P_{tot}	Power dissipation at $T_c = 25^\circ\text{C}$	7.3	W
T_j	Junction operating temperature	Internally limited	$^\circ\text{C}$
T_{stg}	Storage temperature	- 55 to 150	$^\circ\text{C}$

2.2 Thermal data

Table 4. Thermal data

Symbol	Parameter	Max. value		Unit
$R_{thj-case}$	PowerSSO-12 thermal resistance junction-case	17		$^\circ\text{C}/\text{W}$
$R_{thj-amb}$	PowerSSO-12 thermal resistance junction-ambient	61 ⁽¹⁾	50 ⁽²⁾	$^\circ\text{C}/\text{W}$

1. When mounted on a standard single-sided FR-4 board with 0.5 cm² of Cu (at least 35mm thick) connected to all V_{CC} pins.
2. When mounted on a standard single-sided FR-4 board with 8 cm² of Cu (at least 35mm thick) connected to all V_{CC} pins.

2.3 Electrical characteristics

Values specified in this section are for $8V < V_{CC} < 36V$; $-40^{\circ}C < T_j < 150^{\circ}C$, unless otherwise stated.

Figure 3. Current and voltage conventions

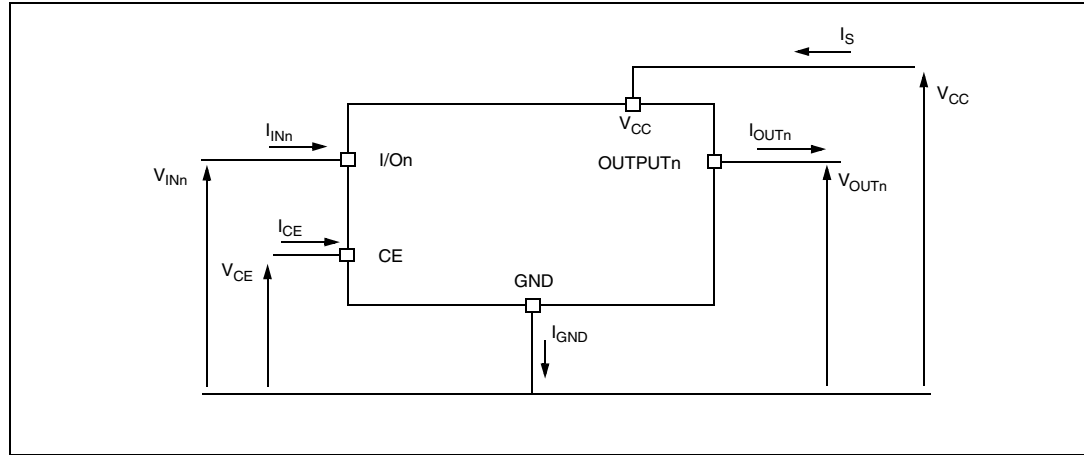

Table 5. Power

Symbol	Parameter	Test conditions	Min.	Typ.	Max.	Unit
$V_{CC}^{(1)}$	Operating supply voltage		5.5	13	36	V
$V_{USD}^{(1)}$	Undervoltage shutdown		3	4	5.5	V
$V_{OV}^{(1)}$	Overvoltage shutdown		36			V
R_{ON}	On-state resistance	$I_{OUTn} = 0.25A$; $T_j = 25^{\circ}C$ $I_{OUTn} = 0.25A$			500 1000	$m\Omega$ $m\Omega$
I_S	Supply current	Off-state; $V_{CC} = 13V$; $V_{CE} = V_{I/On} = 0V$; $V_{CE} = V_{I/On} = 0V$; $V_{CC} = 13V$; $T_{case} = 25^{\circ}C$ On-state (all channels ON); $V_{CC} = 13V$			25 20 8	μA μA mA
$I_{LGND}^{(1)}$	Output current at turn-off	$V_{CC} = V_{CE} = V_{I/On} = V_{GND} = 13V$; $V_{OUTn} = 0V$			1	mA
$I_{L(off1)}^{(1)}$	Off-state output current	$V_{I/On} = V_{OUTn} = 0V$	0		50	μA
$I_{L(off3)}^{(1)}$	Off-state output current	$V_{I/On} = V_{OUTn} = 0V$; $V_{CC} = 13V$; $T_j = 125^{\circ}C$			5	μA
$I_{L(off4)}^{(1)}$	Off-state output current	$V_{I/On} = V_{OUTn} = 0V$; $V_{CC} = 13V$; $T_j = 25^{\circ}C$			3	μA

1. Per channel.

Table 6. Switching ($V_{CC} = 13V$)

Symbol	Parameter	Test conditions	Min.	Typ.	Max.	Unit
t_{on}	Turn-on time	$R_L = 52\Omega$ from 80% $V_{OUT}^{(1)}$		50		μs
t_{off}	Turn-off time	$R_L = 52\Omega$ to 10% $V_{OUT}^{(1)}$		75		μs
$dV_{OUT}/dt_{(on)}$	Turn-on voltage slope	$R_L = 52\Omega$ from $V_{OUT} = 1.3V$ to $V_{OUT} = 10.4V^{(1)}$		0.3		$V/\mu s$
$dV_{OUT}/dt_{(off)}$	Turn-off voltage slope	$R_L = 52\Omega$ from $V_{OUT} = 11.7V$ to $V_{OUT} = 1.3V^{(1)}$		0.3		$V/\mu s$

1. See [Figure 4: Switching time waveforms: turn-on and turn-off](#).

Table 7. Input and CE pin

Symbol	Parameter	Test conditions	Min.	Typ.	Max.	Unit
V_{INL}	I/O low level				1.25	V
I_{INL}	Low level I/O current	$V_{IN} = 1.25V$	1			μA
V_{INH}	I/O high level		3.25			V
I_{INH}	High level I/O current	$V_{IN} = 3.25V$			10	μA
$V_{I(hyst)}$	I/O hysteresis voltage		0.5			V
V_{ICL}	Input clamp voltage	$I_{IN} = 1mA$ $I_{IN} = -1mA$	6	6.8 -0.7	8	V V

Table 8. Protections and diagnostics⁽¹⁾

Symbol	Parameter	Test conditions	Min.	Typ.	Max.	Unit
V_{OL}	I/O low level default detection	$I_{IN} = 1mA$, latched thermal shutdown			0.5	V
T_{TSD}	Junction shutdown temperature		150	175	200	$^{\circ}C$
I_{lim}	DC short circuit current	$V_{CC} = 13V$; $R_{LOAD} = 10m\Omega$	0.4	0.6	0.9	A
V_{demag}	Turn-off output clamp voltage	$I_{OUT} = 0.25 A$; $L = 50mH$	$V_{CC} - 41$	$V_{CC} - 48$	$V_{CC} - 55$	V
t_{reset}	Thermal latch reset time	$T_j < T_{TSD}$ (see third figure in Figure 6: Waveforms)			10	μs

1. To ensure long term reliability under heavy overload or short circuit conditions, protection and related diagnostic signals must be used together with a proper software strategy. If the device is subjected to abnormal conditions, this software must limit the duration and number of activation cycles.

Figure 4. Switching time waveforms: turn-on and turn-off

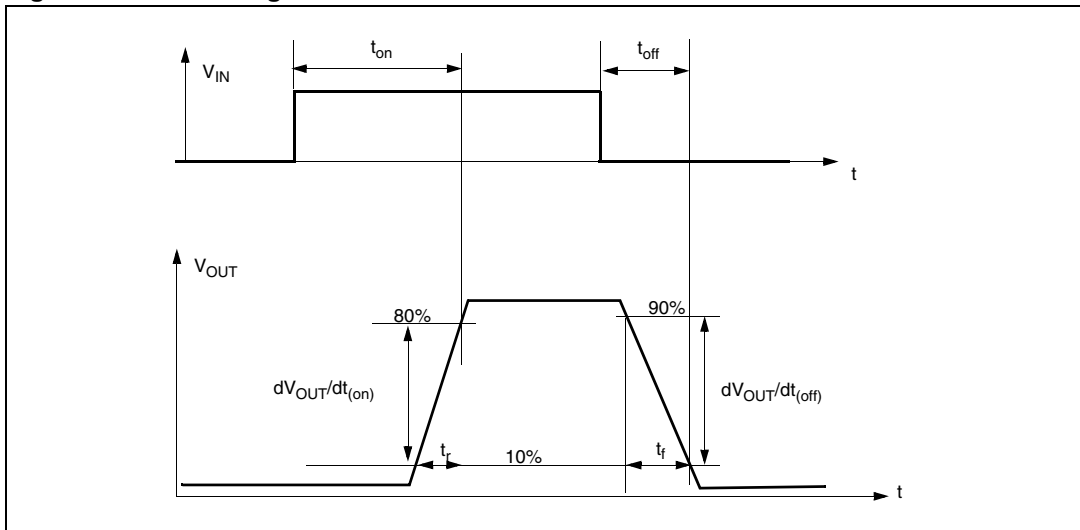
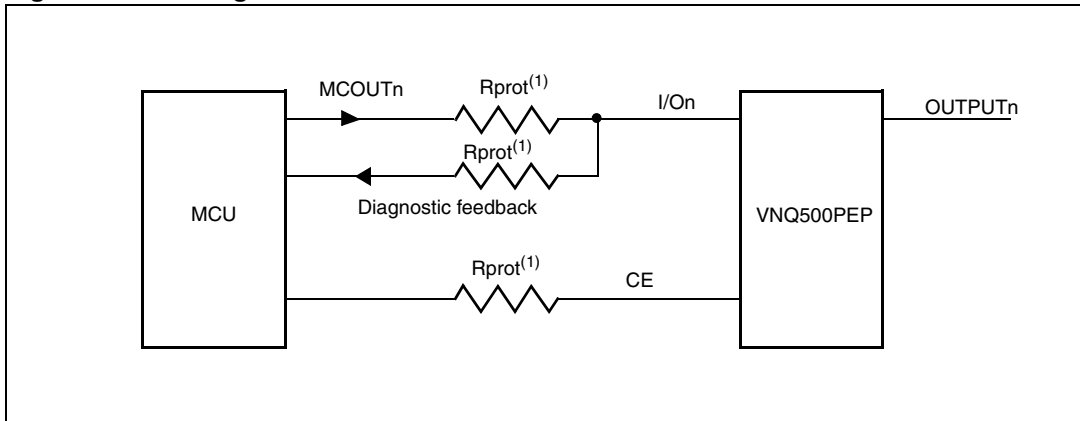

Figure 5. Driving circuit



1. See [Figure 19: Application schematic](#).

Table 9. Truth table

Conditions	MCOUTn	CE	I/On	Output_n
Normal operation	L	H	L	L
	H	H	H	H
Current limitation	L	H	L	L
	H	H	H	H
Over temperature	L	H	L	L
	H	H	L (latched)	L
Undervoltage	L	H	L	L
	H	H	H	L
Standby	X	L	X	L

Table 10. Electrical transient requirements on V_{CC} pin

ISO T/R 7637/1 Test pulse	Test level				Delays and impedance
	I	II	III	IV	
1	- 25V ⁽¹⁾	- 50V ⁽¹⁾	- 75V ⁽¹⁾	- 100V ⁽¹⁾	2ms, 10Ω
2	+ 25V ⁽¹⁾	+ 50V ⁽¹⁾	+ 75V ⁽¹⁾	+ 100V ⁽¹⁾	0.2ms, 10Ω
3a	- 25V ⁽¹⁾	- 50V ⁽¹⁾	- 100V ⁽¹⁾	- 150V ⁽¹⁾	0.1μs, 50Ω
3b	+ 25V ⁽¹⁾	+ 50V ⁽¹⁾	+ 75V ⁽¹⁾	+ 100V ⁽¹⁾	0.1μs, 50Ω
4	- 4V ⁽¹⁾	- 5V ⁽¹⁾	- 6V ⁽¹⁾	- 7V ⁽¹⁾	100ms, 0.01Ω
5	+ 26.5V ⁽¹⁾	+ 46.5V ⁽²⁾	+ 66.5V ⁽²⁾	+ 86.5V ⁽²⁾	400ms, 2Ω

1. All functions of the device are performed as designed after exposure to disturbance.
2. One or more functions of the device is not performed as designed after exposure and cannot be returned to proper operation without replacing the device.

Figure 6. Waveforms

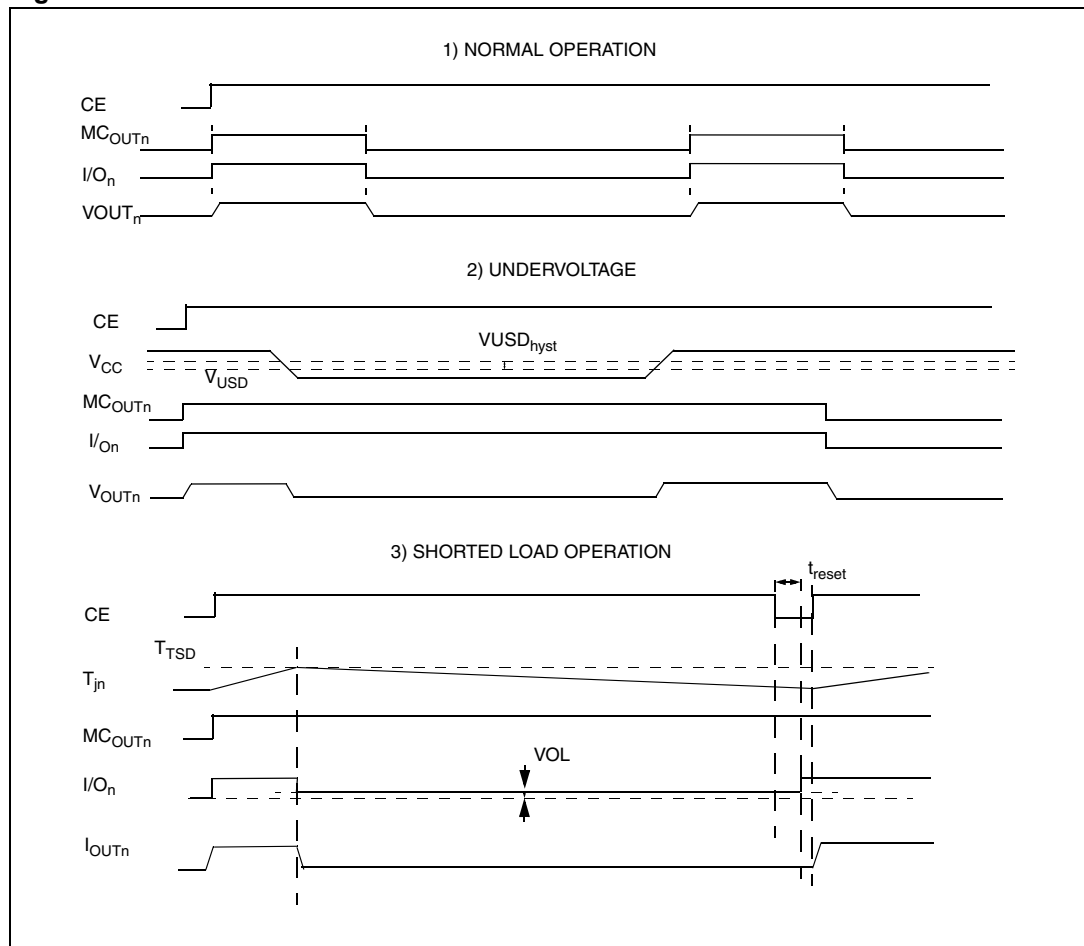

2.4 Electrical characteristics curves

Figure 7. Off-state output current

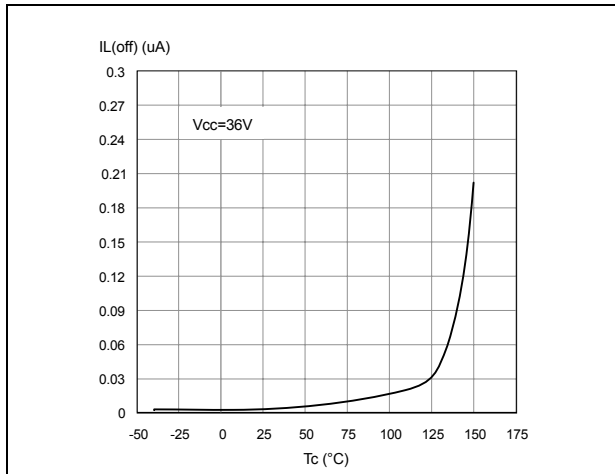

Figure 8. High level input current

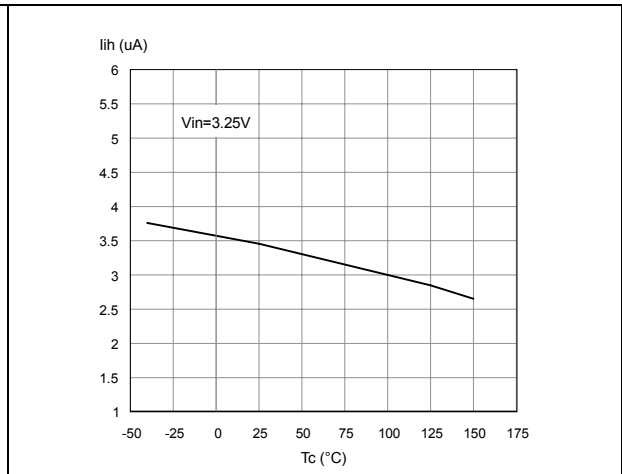

Figure 9. Input clamp voltage

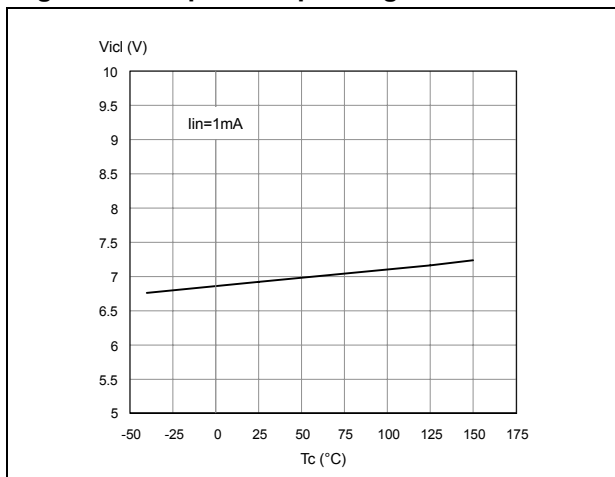

Figure 10. Turn-off voltage slope

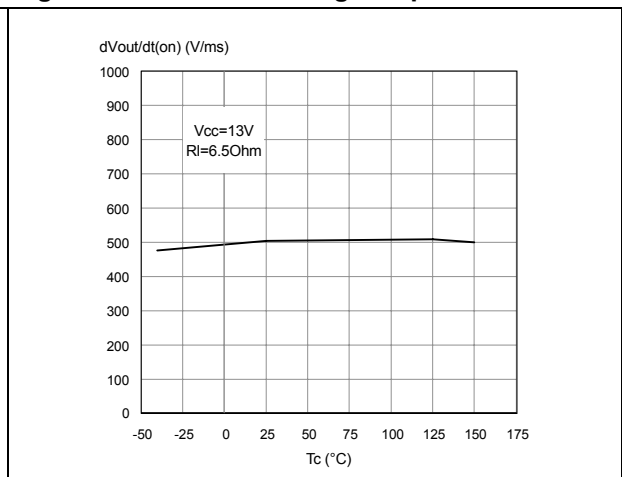

Figure 11. Overvoltage shutdown

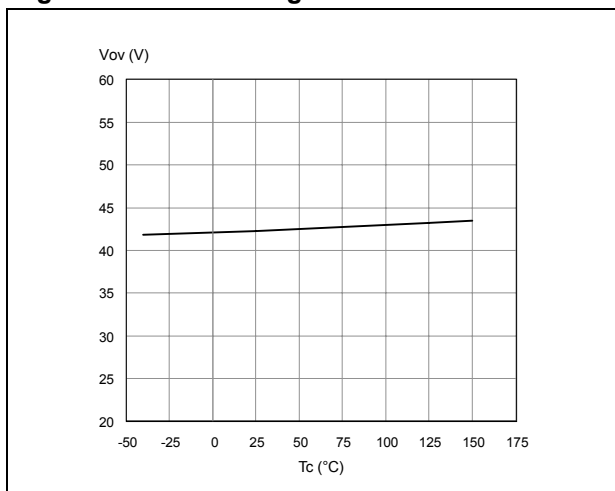

Figure 12. Turn-off voltage slope

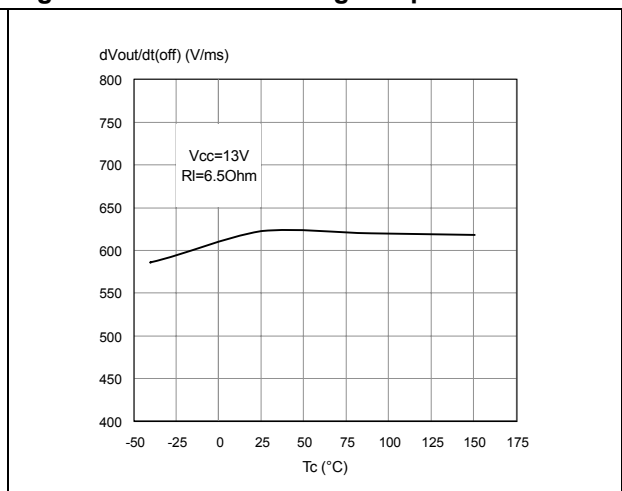

Figure 13. I_{LIM} vs T_{case}

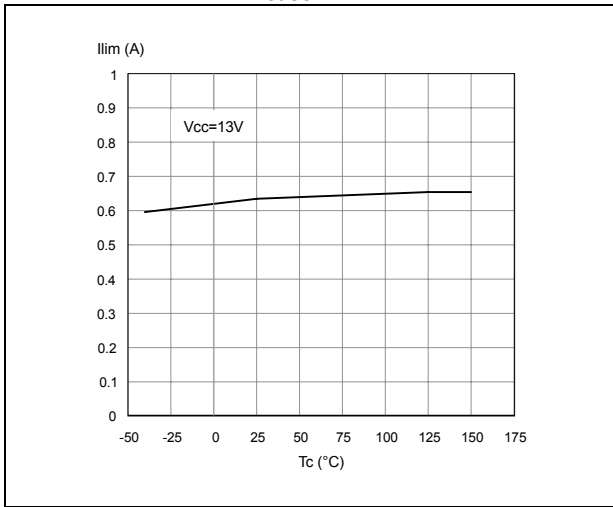

Figure 14. On-state resistance vs V_{CC}

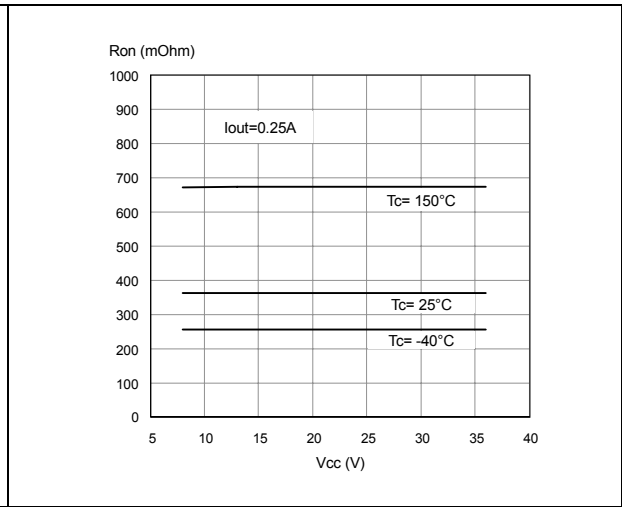

Figure 15. Input high level

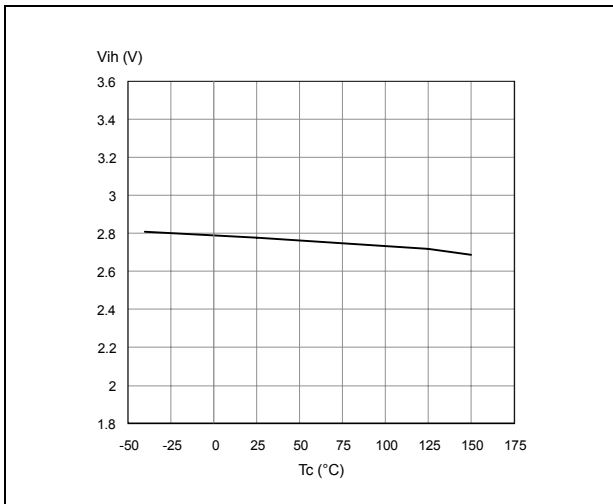

Figure 16. Input hysteresis voltage

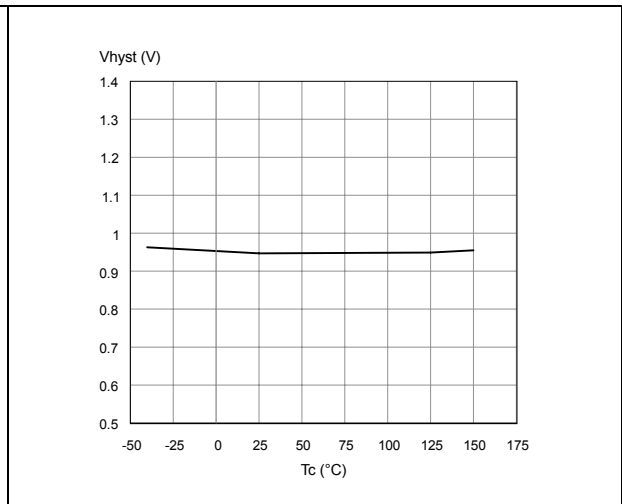

Figure 17. On-state resistance vs T_{case}

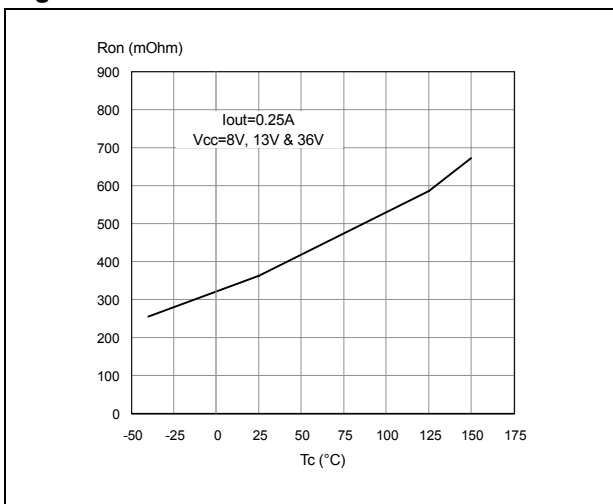
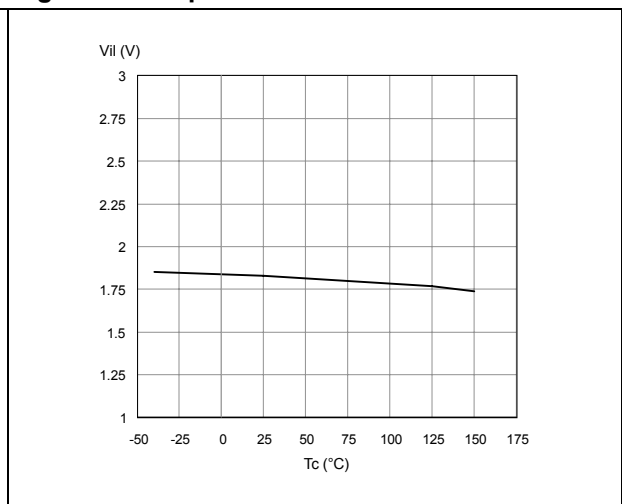
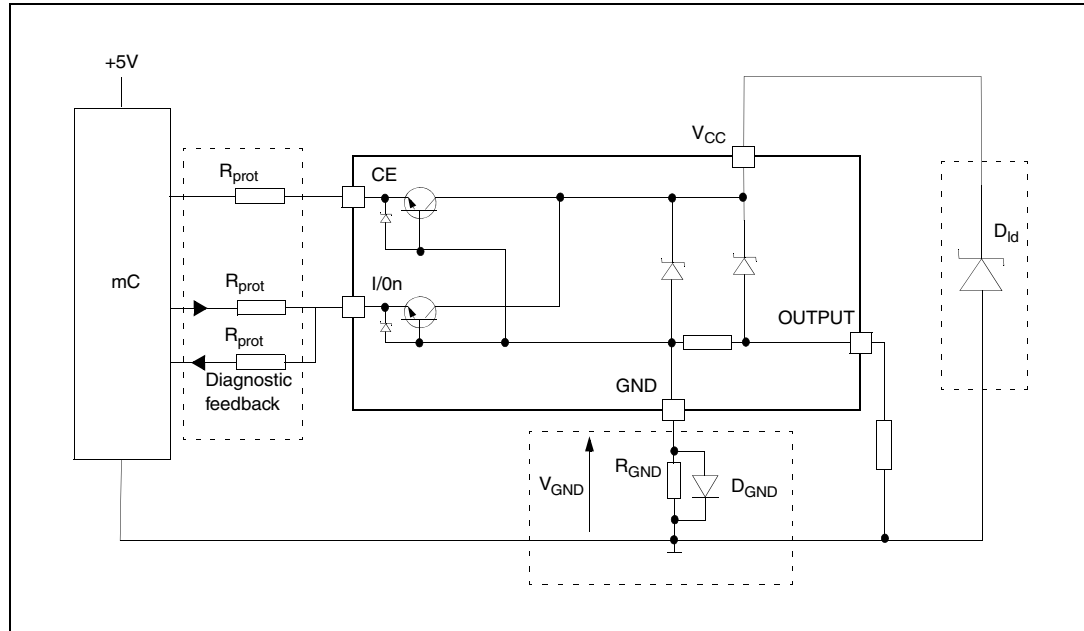

Figure 18. Input low level



3 Application information

Figure 19. Application schematic



3.1 GND protection network against reverse battery

This section provides two solutions for implementing a ground protection network against reverse battery.

3.1.1 Solution 1: a resistor in the ground line (R_{GND} only)

This can be used with any type of load.

The following show how to dimension the R_{GND} resistor:

1. $R_{GND} \leq 600\text{mV} / (I_{S(on)max})$
2. $R_{GND} \geq (-V_{CC}) / (-I_{GND})$

where -I_{GND} is the DC reverse ground pin current and can be found in the absolute maximum rating section of the device datasheet.

Power dissipation in R_{GND} (when V_{CC}<0 during reverse battery situations) is:

$$P_D = (-V_{CC})^2 / R_{GND}$$

This resistor can be shared amongst several different HSDs. Please note that the value of this resistor should be calculated with formula (1) where I_{S(on)max} becomes the sum of the maximum on-state currents of the different devices.

Please note that, if the microprocessor ground is not shared by the device ground, then the R_{GND} will produce a shift (I_{S(on)max} * R_{GND}) in the input thresholds and the status output values. This shift will vary depending on how many devices are ON in the case of several high-side drivers sharing the same R_{GND}.

If the calculated power dissipation requires the use of a large resistor, or several devices have to share the same resistor, then ST suggests using solution 2 below.

3.1.2 Solution 2: a diode (D_{GND}) in the ground line

Note that a resistor ($R_{GND}=1k\Omega$) should be inserted in parallel to D_{GND} if the device drives an inductive load.

This small signal diode can be safely shared amongst several different HSDs. Also in this case, the presence of the ground network will produce a shift ($\approx 600mV$) in the input threshold and in the status output values if the microprocessor ground is not common to the device ground. This shift will not vary if more than one HSD shares the same diode/resistor network.

3.2 Load dump protection

D_{ld} is necessary (Voltage Transient Suppressor) if the load dump peak voltage exceeds the V_{CC} maximum DC rating. The same applies if the device is subject to transients on the V_{CC} line that are greater than those shown in the ISO T/R 7637/1 table.

3.3 MCU I/O protection

If a ground protection network is used and negative transients are present on the V_{CC} line, the control pins will be pulled negative. ST suggests to insert a resistor (R_{prot}) in line to prevent the μC I/O pins from latching up.

The value of these resistors is a compromise between the leakage current of μC and the current required by the HSD I/Os (Input levels compatibility) with the latch-up limit of μC I/Os:

$$-V_{CCpeak}/I_{latchup} \leq R_{prot} \leq (V_{OH\mu C} - V_{IH} - V_{GND}) / I_{IHmax}$$

Example

For the following conditions:

$$V_{CCpeak} = -100V$$

$$I_{latchup} \geq 20mA$$

$$V_{OH\mu C} \geq 4.5V$$

$$5k\Omega \leq R_{prot} \leq 180k\Omega$$

Recommended values are:

$$R_{prot} = 10k\Omega$$

3.4 Maximum demagnetization energy ($V_{CC} = 13.5V$)

Figure 20. Maximum turn-off current versus load inductance

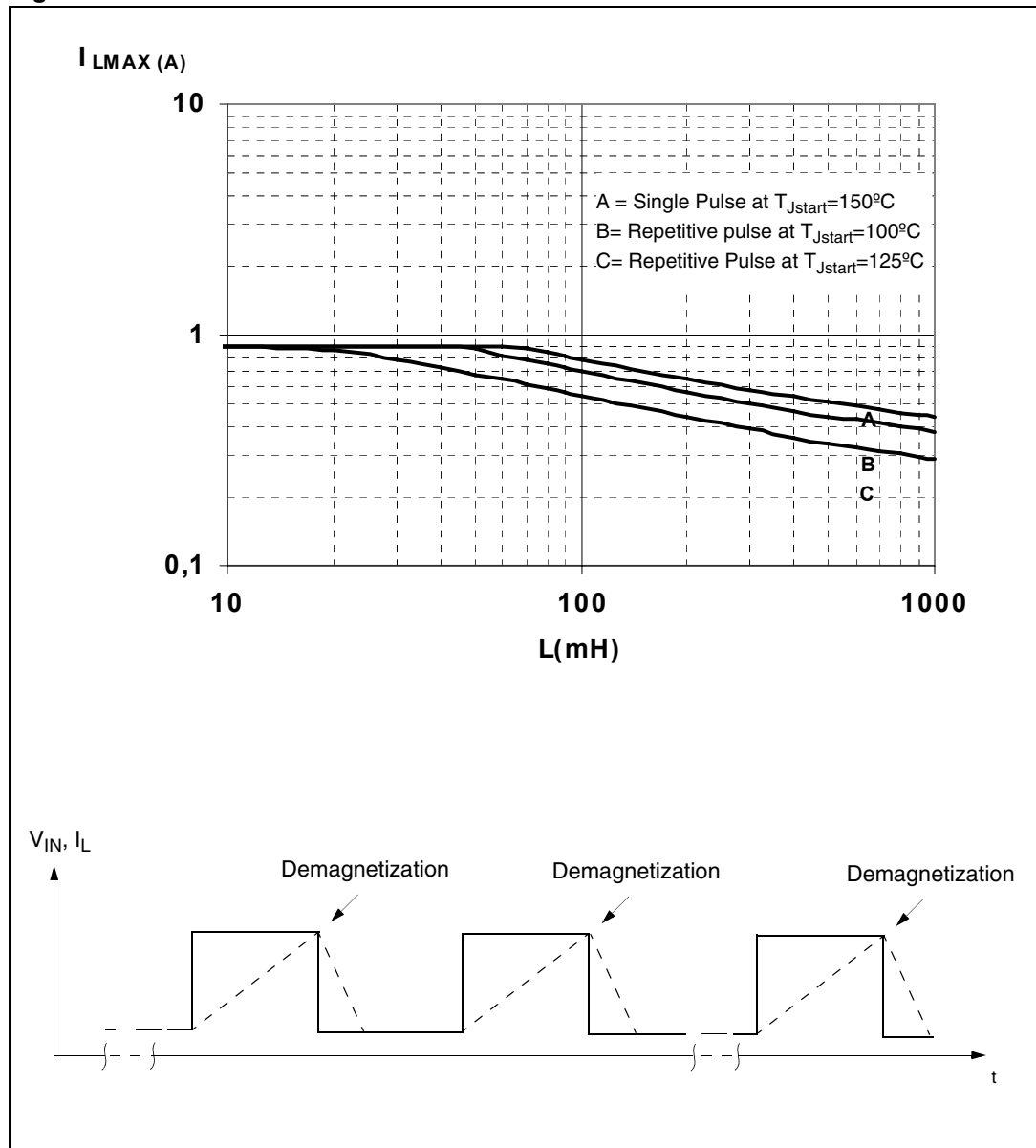

Note: Values are generated with $R_L = 0 \Omega$.
 In case of repetitive pulses, T_{Jstart} (at beginning of each demagnetization) of every pulse must not exceed the temperature specified above for curves B and C.

4 Package and thermal data

4.1 PowerSSO-12 thermal data

Figure 21. PowerSSO-12 PC board

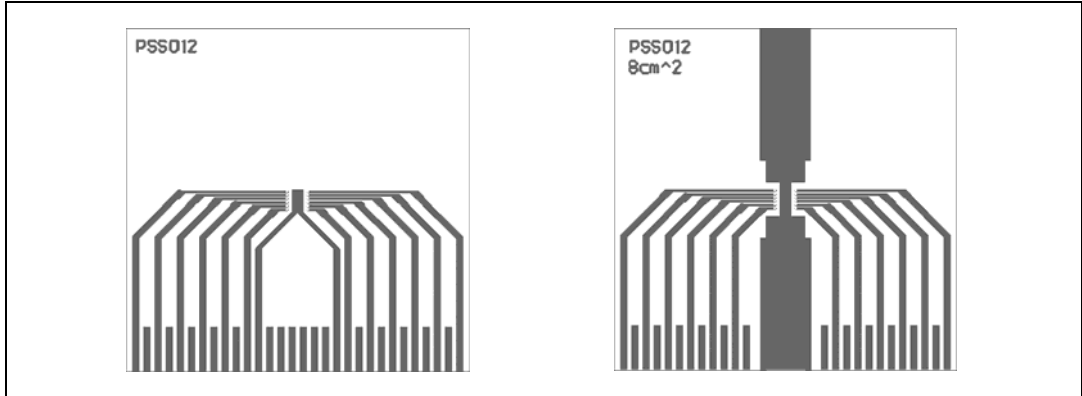

Note: Layout condition of R_{th} and Z_{th} measurements (PCB FR4 area= 78mm x 78mm, PCB thickness=2mm, Cu thickness=35 μ m, Copper areas: from minimum pad lay-out to 16 cm²).

Figure 22. $R_{thj-amb}$ Vs PCB copper area in open box free air condition

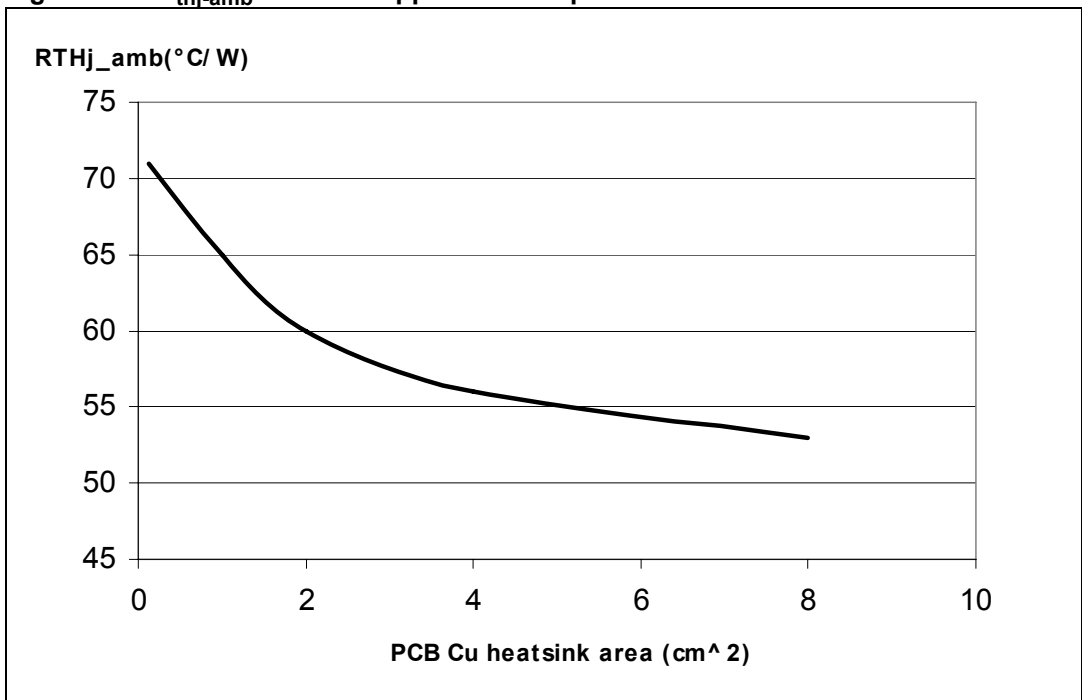
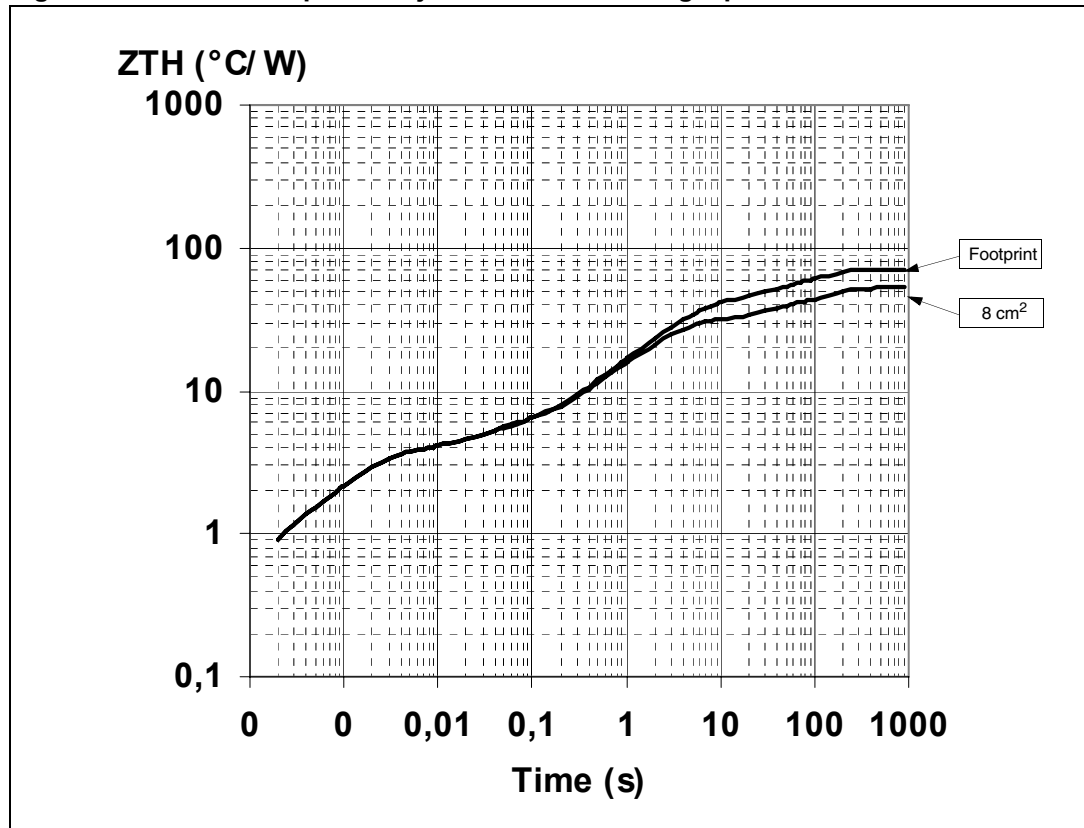

Figure 23. Thermal impedance junction ambient single pulse



Equation 1: pulse calculation formula

$$Z_{TH\delta} = R_{TH} \cdot \delta + Z_{THtp}(1 - \delta)$$

where $\delta = t_p/T$

Figure 24. Thermal fitting model of a quad channel HSD in PowerSSO-12

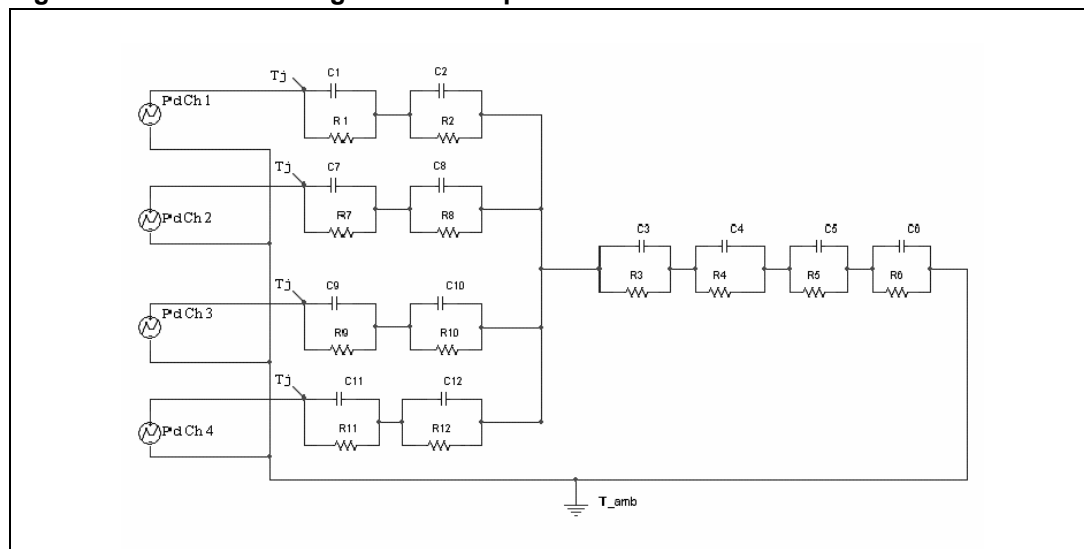

Table 11. Thermal parameter

Area/island (cm ²)	Footprint	8
R1=R7=R9=R11 (°C/W)	0.8	
R2=R8=R10=R12 (°C/W)	2.6	
R3 (°C/W)	1.5	
R4 (°C/W)	8	
R5 (°C/W)	28	18
R6 (°C/W)	30	22
C1=C7=C9=C11 (W.s/°C)	0.00006	
C2=C8=C10=C12 (W.s/°C)	0.0005	
C3 (W.s/°C)	0.015	
C4 (W.s/°C)	0.1	
C5 (W.s/°C)	0.15	0.17
C6 (W.s/°C)	3	5

5 Package and packing information

5.1 ECOPACK[®] packages

In order to meet environmental requirements, ST offers these devices in different grades of ECOPACK[®] packages, depending on their level of environmental compliance. ECOPACK[®] specifications, grade definitions and product status are available at: www.st.com.

ECOPACK[®] is an ST trademark.

5.2 PowerSSO-12 mechanical data

Table 12. PowerSSO-12 mechanical data

Symbol	Millimeters		
	Min.	Typ.	Max.
A	1.250		1.620
A1	0.000		0.100
A2	1.100		1.650
B	0.230		0.410
C	0.190		0.250
D	4.800		5.000
E	3.800		4.000
e		0.800	
H	5.800		6.200
h	0.250		0.500
L	0.400		1.270
k	0°		8°
X	1.900		2.500
Y	3.600		4.200
ddd			0.100

Figure 25. PowerSSO-12 package dimensions

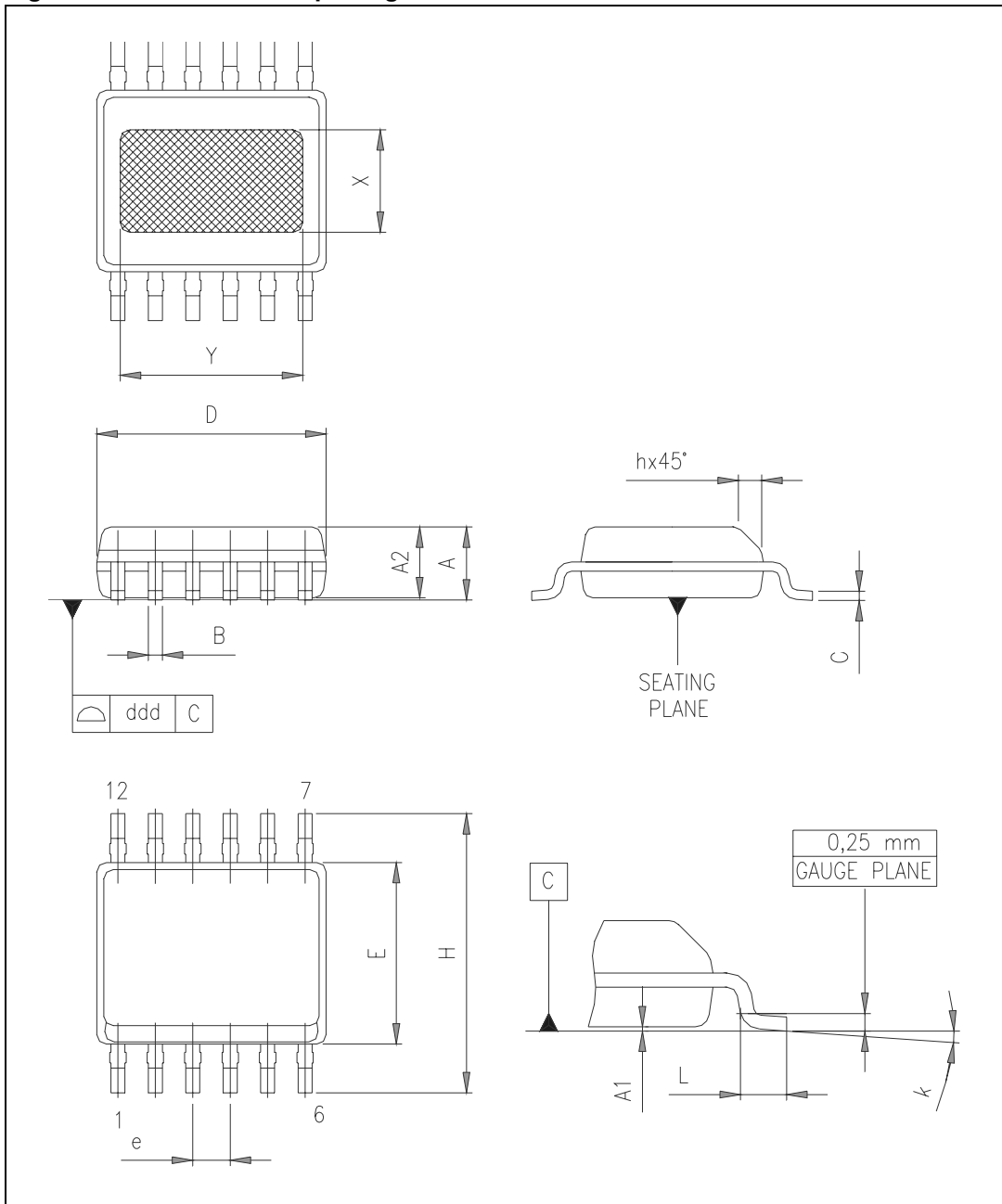

5.3 PowerSSO-12 packing information

Figure 26. PowerSSO-12 tube shipment (no suffix)

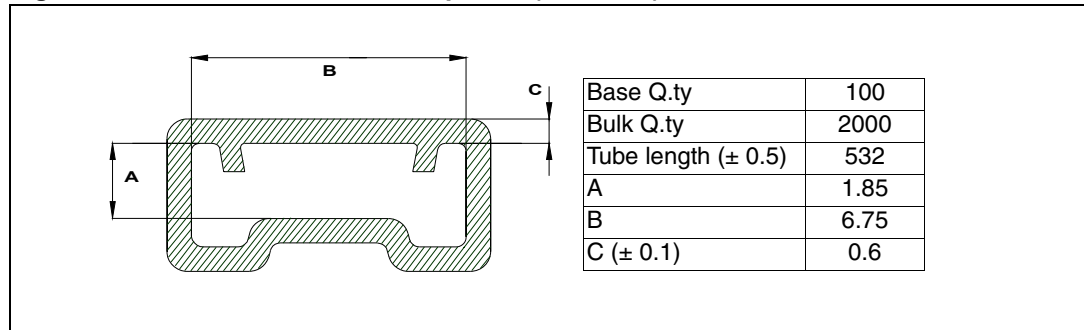
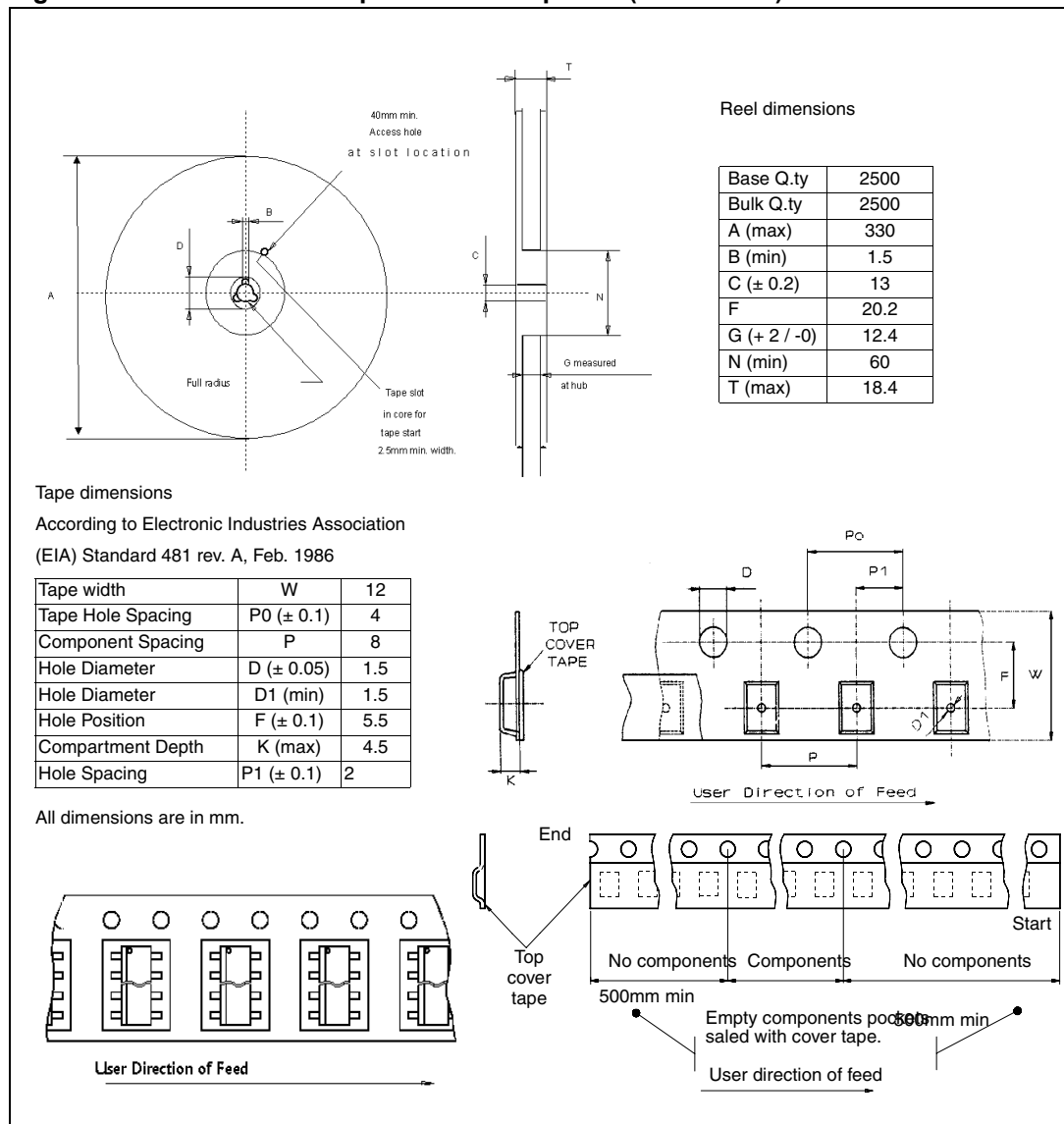

Figure 27. PowerSSO-12 tape and reel shipment (suffix “TR”)



6 Revision history

Table 13. Document revision history

Date	Revision	Changes
24-Jan-2006	1	Initial release.
09-Dec-2008	2	Document restructured and reformatted. Updated Table 3: Absolute maximum ratings - corrected P _{tot} value. Updated Table 4: Thermal data . Updated Figure 6: Waveforms - corrected MC _{OUTn} signal. Updated Table 10: Electrical transient requirements on VCC pin . Corrected Figure 22: Rthj-amb Vs PCB copper area in open box free air condition . Added ECOPACK® packages information.
14-Jul-2009	3	Replaced the obsolete root part number VNQ500PEP-E with the new root part number VNQ500.

Please Read Carefully:

Information in this document is provided solely in connection with ST products. STMicroelectronics NV and its subsidiaries ("ST") reserve the right to make changes, corrections, modifications or improvements, to this document, and the products and services described herein at any time, without notice.

All ST products are sold pursuant to ST's terms and conditions of sale.

Purchasers are solely responsible for the choice, selection and use of the ST products and services described herein, and ST assumes no liability whatsoever relating to the choice, selection or use of the ST products and services described herein.

No license, express or implied, by estoppel or otherwise, to any intellectual property rights is granted under this document. If any part of this document refers to any third party products or services it shall not be deemed a license grant by ST for the use of such third party products or services, or any intellectual property contained therein or considered as a warranty covering the use in any manner whatsoever of such third party products or services or any intellectual property contained therein.

UNLESS OTHERWISE SET FORTH IN ST'S TERMS AND CONDITIONS OF SALE ST DISCLAIMS ANY EXPRESS OR IMPLIED WARRANTY WITH RESPECT TO THE USE AND/OR SALE OF ST PRODUCTS INCLUDING WITHOUT LIMITATION IMPLIED WARRANTIES OF MERCHANTABILITY, FITNESS FOR A PARTICULAR PURPOSE (AND THEIR EQUIVALENTS UNDER THE LAWS OF ANY JURISDICTION), OR INFRINGEMENT OF ANY PATENT, COPYRIGHT OR OTHER INTELLECTUAL PROPERTY RIGHT.

UNLESS EXPRESSLY APPROVED IN WRITING BY AN AUTHORIZED ST REPRESENTATIVE, ST PRODUCTS ARE NOT RECOMMENDED, AUTHORIZED OR WARRANTED FOR USE IN MILITARY, AIR CRAFT, SPACE, LIFE SAVING, OR LIFE SUSTAINING APPLICATIONS, NOR IN PRODUCTS OR SYSTEMS WHERE FAILURE OR MALFUNCTION MAY RESULT IN PERSONAL INJURY, DEATH, OR SEVERE PROPERTY OR ENVIRONMENTAL DAMAGE. ST PRODUCTS WHICH ARE NOT SPECIFIED AS "AUTOMOTIVE GRADE" MAY ONLY BE USED IN AUTOMOTIVE APPLICATIONS AT USER'S OWN RISK.

Resale of ST products with provisions different from the statements and/or technical features set forth in this document shall immediately void any warranty granted by ST for the ST product or service described herein and shall not create or extend in any manner whatsoever, any liability of ST.

ST and the ST logo are trademarks or registered trademarks of ST in various countries.

Information in this document supersedes and replaces all information previously supplied.

The ST logo is a registered trademark of STMicroelectronics. All other names are the property of their respective owners.

© 2009 STMicroelectronics - All rights reserved

STMicroelectronics group of companies

Australia - Belgium - Brazil - Canada - China - Czech Republic - Finland - France - Germany - Hong Kong - India - Israel - Italy - Japan - Malaysia - Malta - Morocco - Philippines - Singapore - Spain - Sweden - Switzerland - United Kingdom - United States of America

www.st.com