



VND5N07

OMNIFET II

fully autoprotected Power MOSFET

Features

| | | |
|------------------------------------|--------------|--------------|
| Max. on-state resistance (per ch.) | $R_{DS(on)}$ | 0.2 Ω |
| Current limitation (typ) | I_{LIMH} | 5 A |
| Drain-Source clamp voltage | V_{CLAMP} | 70V |

- Linear current limitation
- Thermal shutdown
- Short circuit protection
- Integrated clamp
- Low current drawn from input pin
- Diagnostic feedback through input pin
- ESD protection
- Direct access to the gate of the power mosfet (analog driving)
- Compatible with standard Power MOSFET

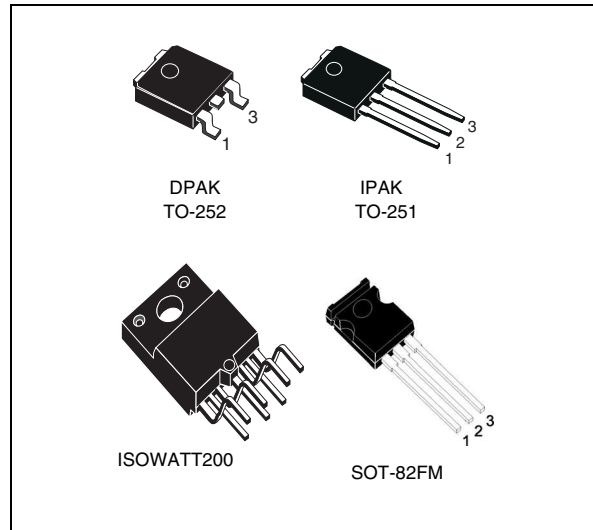

Description

The VND5N07 is a monolithic device designed in STMicroelectronics VIPower M0 technology, intended for replacement of standard Power MOSFETs from DC to 50KHz applications. Built in thermal shutdown, linear current limitation and overvoltage clamp protect the chip in harsh environments.

Fault feedback can be detected by monitoring the voltage at the input pin.

Table 1. Device summary

| Package | Order codes | |
|------------|-------------|---------------|
| | Tube | Tape and reel |
| DPAK | VND5N07 | VND5N0713TR |
| IPAK | VND5N07-1 | |
| ISOWATT220 | VNP5N07FI | |
| SOT-82FM | VNK5N07FM | |

Contents

- 1 Block diagram and pin description 5**

- 2 Electrical specifications 6**
 - 2.1 Absolute maximum ratings 6
 - 2.2 Thermal data 6
 - 2.3 Electrical characteristics 7
 - 2.4 Electrical characteristics curves 13

- 3 Protection features 17**
 - 3.1 Overvoltage clamp protection 17
 - 3.2 Linear current limiter circuit 17
 - 3.3 Overtemperature and short circuit protection 17
 - 3.4 Status feedback 17

- 4 Package and packing information 18**
 - 4.1 ECOPACK® packages 18
 - 4.2 DPAK mechanical data 18
 - 4.3 IPAK mechanical data 20
 - 4.4 ISOWATT220 mechanical data 21
 - 4.5 SOT-82FM mechanical data 22

- 5 Revision history 23**

List of tables

| | | |
|-----------|--|----|
| Table 1. | Device summary | 1 |
| Table 2. | Absolute maximum ratings | 6 |
| Table 3. | Thermal data | 6 |
| Table 4. | Off | 7 |
| Table 5. | On | 7 |
| Table 6. | Dynamic | 7 |
| Table 7. | Switching | 8 |
| Table 8. | Source Drain diode | 8 |
| Table 9. | Protections (-40°C < T _j < 150°C, unless otherwise specified) | 8 |
| Table 10. | DPAK mechanical data | 19 |
| Table 11. | IPAK mechanical data | 20 |
| Table 12. | ISOWATT220 mechanical data | 21 |
| Table 13. | SOT-82FM mechanical data | 22 |
| Table 14. | Document revision history | 23 |

List of figures

| | | |
|------------|---|----|
| Figure 1. | Block diagram | 5 |
| Figure 2. | Switching time test circuit for resistive load | 9 |
| Figure 3. | Test circuit for diode recovery times | 9 |
| Figure 4. | Unclamped inductive load test circuits | 10 |
| Figure 5. | Input charge test circuit. | 10 |
| Figure 6. | Unclamped inductive waveforms | 11 |
| Figure 7. | Switching waveforms | 11 |
| Figure 8. | Thermal impedance for ISOWATT220 | 12 |
| Figure 9. | Thermal impedance for DPAK / IPAK | 12 |
| Figure 10. | Source-Drain diode forward characteristics | 13 |
| Figure 11. | Static Drain-Source on resistance | 13 |
| Figure 12. | Derating curve | 13 |
| Figure 13. | Static Drain-Source on resistance vs. input voltage | 13 |
| Figure 14. | Normalized on resistance Vs temperature | 13 |
| Figure 15. | Transconductance | 13 |
| Figure 16. | Static Drain-Source on resistance Vs. Id | 14 |
| Figure 17. | Switching time resistive load. | 14 |
| Figure 18. | Turn-on current slope | 14 |
| Figure 19. | Turn-on current slope | 14 |
| Figure 20. | Input voltage Vs. input charge | 14 |
| Figure 21. | Turn-off Drain source voltage slope | 14 |
| Figure 22. | Turn-off Drain-Source voltage slope. | 15 |
| Figure 23. | Capacitance variations | 15 |
| Figure 24. | Switching time resistive load. | 15 |
| Figure 25. | Step response current limit. | 15 |
| Figure 26. | Output characteristics | 15 |
| Figure 27. | Normalized on resistance Vs. temperature. | 15 |
| Figure 28. | Normalized Input threshold voltage Vs. temperature | 16 |
| Figure 29. | Normalized current limit Vs. junction temperature | 16 |
| Figure 30. | DPAK package dimensions | 18 |
| Figure 31. | IPAK mechanical data and package outline | 20 |
| Figure 32. | ISOWATT220 mechanical data and package outline | 21 |
| Figure 33. | SOT-82FM mechanical data and package outline | 22 |

1 Block diagram and pin description

Figure 1. Block diagram

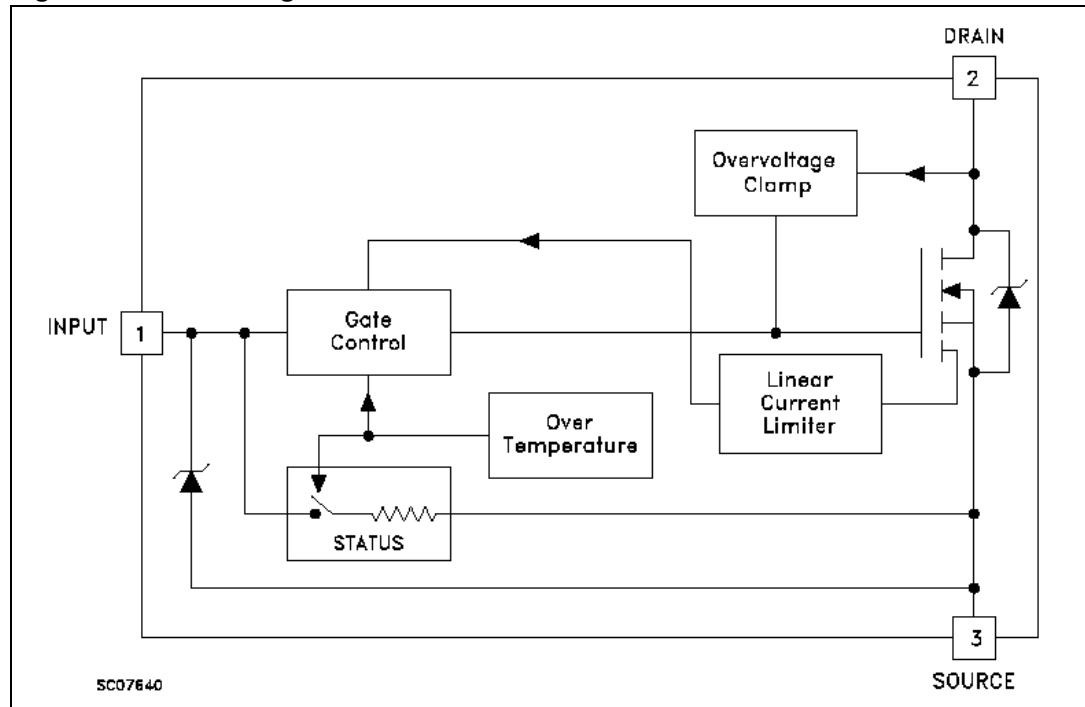

2 Electrical specifications

2.1 Absolute maximum ratings

Stressing the device above the rating listed in the “Absolute maximum ratings” table may cause permanent damage to the device. These are stress ratings only and operation of the device at these or any other conditions above those indicated in the operating sections of this specification is not implied. Exposure to Absolute maximum rating conditions for extended periods may affect device reliability. Refer also to the STMicroelectronics SURE program and other relevant quality document.

Table 2. Absolute maximum ratings

| Symbol | Parameter | Value | | | Unit |
|-----------|---|--------------------|------------|----------|------------|
| | | DPAK / IPAK | ISOWATT220 | SOT-82FM | |
| V_{DSn} | Drain-Source voltage ($V_{INn} = 0V$) | Internally clamped | | | V |
| V_{INn} | Input voltage | 18 | | | V |
| I_{Dn} | Drain current | Internally limited | | | A |
| I_{Rn} | Reverse DC output current | -7 | | | A |
| V_{ESD} | Electrostatic discharge (R = 1.5K Ω , C = 100pF) | 2000 | | | V |
| P_{tot} | Total dissipation at $T_c = 25^\circ C$ | 60 | 24 | 9 | W |
| T_j | Operating junction temperature | Internally limited | | | $^\circ C$ |
| T_c | Case operating temperature | Internally limited | | | $^\circ C$ |
| T_{stg} | Storage temperature | -55 to 150 | | | $^\circ C$ |

2.2 Thermal data

Table 3. Thermal data

| Symbol | Parameter | Max. value | | | Unit |
|----------------|-------------------------------------|-------------|------------|----------|--------------|
| | | DPAK / IPAK | ISOWATT220 | SOT-82FM | |
| $R_{thj-case}$ | Thermal resistance junction-case | 3.75 | 5.2 | 14 | $^\circ C/W$ |
| $R_{thj-amb}$ | Thermal resistance junction-ambient | 100 | 62.5 | 100 | $^\circ C/W$ |

2.3 Electrical characteristics

T_{case} = 25°C unless otherwise stated.

Table 4. Off

| Symbol | Parameter | Test conditions | Min. | Typ. | Max. | Unit |
|--------------------|--|---|------|------|-----------|----------|
| V _{CLAMP} | Drain-Source clamp voltage | V _{IN} = 0V; I _D = 200mA | 60 | 70 | 80 | V |
| V _{CLTH} | Drain-Source threshold voltage | V _{IN} = 0V; I _D = 2mA | 55 | | | V |
| I _{ISS} | Supply current from input pin | V _{DS} = 0V; V _{IN} = 10V | | 250 | 500 | μA |
| V _{INCL} | Input-Source reverse clamp voltage | I _{IN} = 1mA | -1.0 | | -0.3 | V |
| I _{DSS} | Zero input voltage drain current (V _{IN} =0V) | V _{DS} = 13V; V _{IN} = 0V; V _{DS} = 25V; V _{IN} = 0V | | | 50 200 | μA μA |

Table 5. On⁽¹⁾

| Symbol | Parameter | Test conditions | Min. | Typ. | Max. | Unit |
|---------------------|-----------------------------------|--|------|------|------------|------|
| R _{DS(on)} | Static Drain-Source on resistance | V _{IN} = 10V; I _D = 2.5A; V _{IN} = 5V; I _D = 2.5A | | | 200 280 | mΩ |
| V _{IN(th)} | Input threshold voltage | V _{DS} = V _{in} ; I _D + I _{in} = 1 mA | 0.8 | | 3 | V |

1. Pulsed: pulse duration = 300μs, duty cycle 1.5%.

Table 6. Dynamic

| Symbol | Parameter | Test conditions | Min. | Typ. | Max. | Unit |
|--------------------------------|--------------------------|---|------|------|------|------|
| g _{fs} ⁽¹⁾ | Forward transconductance | V _{DS} = 13V; I _D = 2.5A | 3 | 4 | | S |
| C _{OSS} | Output capacitance | V _{DS} = 13V; f = 1MHz; V _{IN} = 0V | | 200 | 300 | pF |

1. Pulsed: pulse duration = 300μs, duty cycle 1.5%.

Table 7. Switching⁽¹⁾

| Symbol | Parameter | Test conditions | Min. | Typ. | Max. | Unit |
|----------------|-----------------------|---|------|------|------|------------|
| $t_{d(on)}$ | Turn-on delay time | $V_{DD} = 15V; I_D = 2.5A$ $V_{gen} = 10V; R_{gen} = 10\Omega$ | | 50 | 100 | ns |
| t_r | Rise time | | | 60 | 100 | ns |
| $t_{d(off)}$ | Turn-off delay time | | | 150 | 300 | ns |
| t_f | Fall time | | | 40 | 80 | ns |
| $t_{d(on)}$ | Turn-on delay time | $V_{DD} = 15V; I_D = 2.5A$ $V_{gen} = 10V; R_{gen} = 1k\Omega$ | | 150 | 250 | ns |
| t_r | Rise time | | | 400 | 600 | ns |
| $t_{d(off)}$ | Turn-off delay time | | | 3900 | 5000 | ns |
| t_f | Fall time | | | 1100 | 1600 | ns |
| $(di/dt)_{on}$ | Turn-on current slope | $V_{DD} = 15V; I_D = 2.5A$ $V_{in} = 10V; R_{gen} = 10\Omega$ | | 80 | | A/ μ S |
| Q_i | Total input charge | $V_{DD} = 12V; I_D = 2.5A; V_{IN} = 10V$ | | 18 | | nC |

1. Parameters guaranteed by design / characterization.

Table 8. Source Drain diode

| Symbol | Parameter | Test conditions | Min. | Typ. | Max. | Unit |
|-----------------|--------------------------|---|------|------|------|---------|
| $V_{SD}^{(1)}$ | Forward On voltage | $I_{SD} = 2.5A; V_{IN} = 0V$ | | | 1.6 | V |
| $t_{rr}^{(2)}$ | Reverse recovery time | $I_{SD} = 2.5A; di/dt = 100 A/\mu s$ $V_{DD} = 30V;$ | | 150 | | ns |
| $Q_{rr}^{(2)}$ | Reverse recovery charge | | | 0.3 | | μ C |
| $I_{RRM}^{(2)}$ | Reverse recovery current | | | 5.7 | | A |

1. Pulsed: pulse duration = 300 μ s, duty cycle 1.5%.

2. Parameters guaranteed by design / characterization.

Table 9. Protections (-40°C < T_j < 150°C, unless otherwise specified)

| Symbol | Parameter | Test conditions | Min. | Typ. | Max. | Unit |
|------------------|-------------------------------|--|------------|----------|----------|--------------------|
| I_{lim} | Drain current limit | $V_{IN} = 10V; V_{DS} = 13V$ $V_{IN} = 5V; V_{DS} = 13V$ | 3.5 3.5 | 5 5 | 7 7 | A A |
| $t_{dlim}^{(1)}$ | Step response current limit | $V_{IN} = 10V;$ $V_{IN} = 5V$ | | 15 40 | 20 60 | μ S μ S |
| $T_{jsh}^{(1)}$ | Overtemperature shutdown | | 150 | | | °C |
| $T_{jrs}^{(1)}$ | Overtemperature reset | | 135 | | | °C |
| $I_{gf}^{(1)}$ | Fault sink current | $V_{IN} = 10V; V_{DS} = 13V;$ $V_{IN} = 5V; V_{DS} = 13V$ | | 50 20 | | mA mA |
| $E_{as}^{(1)}$ | Single pulse avalanche energy | Starting $T_j = 25^\circ C; V_{DD} = 20V$ $V_{IN} = 10V R_{gen} = 1k\Omega; L = 10mH$ | 0.2 | | | J |

1. Parameters guaranteed by design / characterization.

Figure 2. Switching time test circuit for resistive load

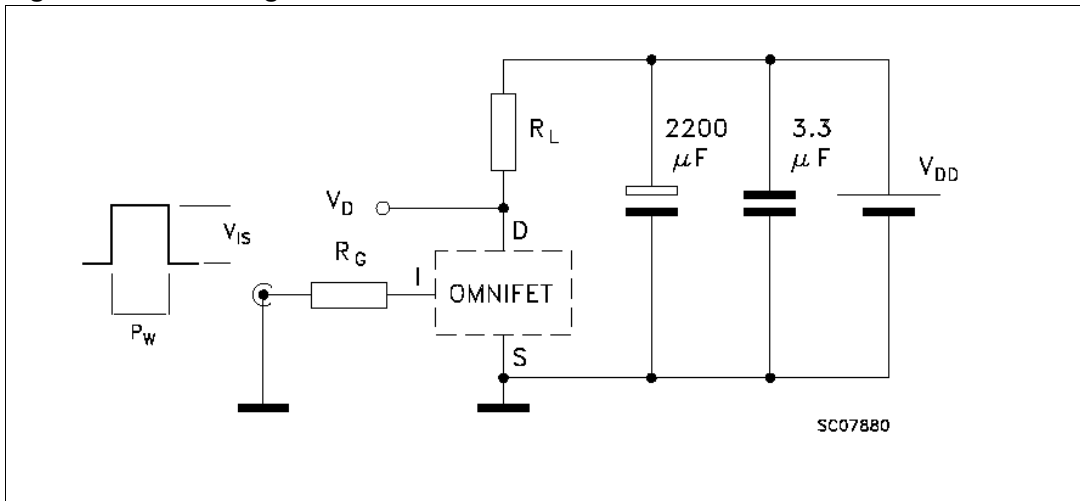

Figure 3. Test circuit for diode recovery times

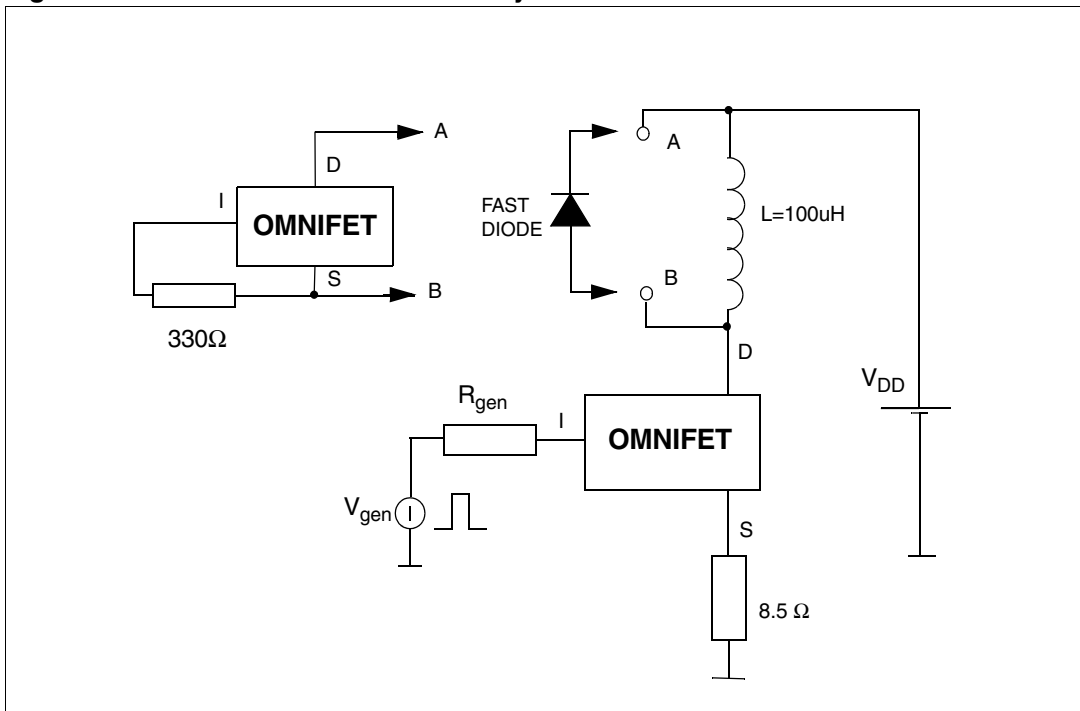

Figure 4. Unclamped inductive load test circuits

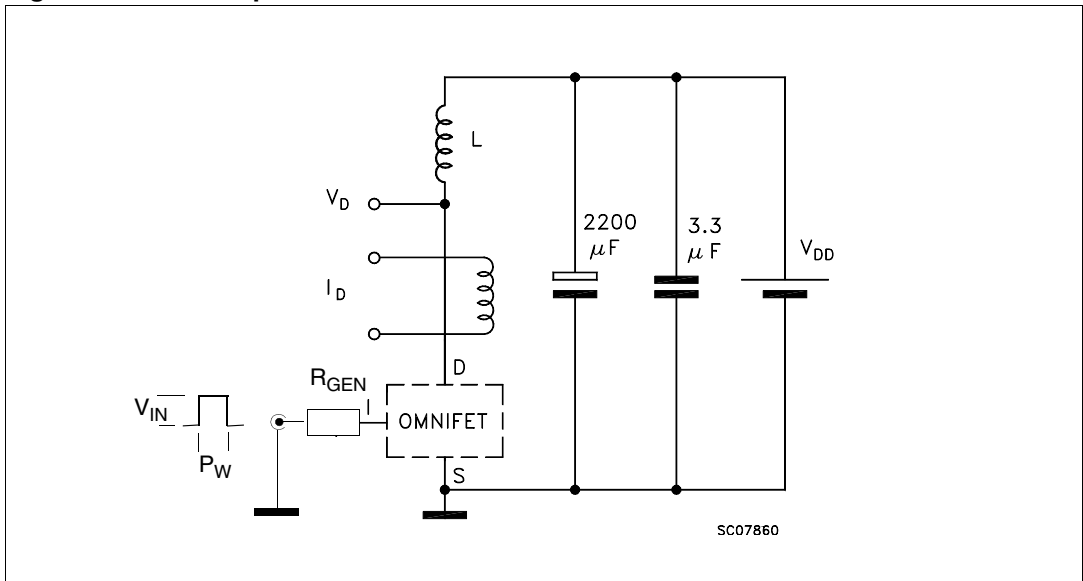

Figure 5. Input charge test circuit

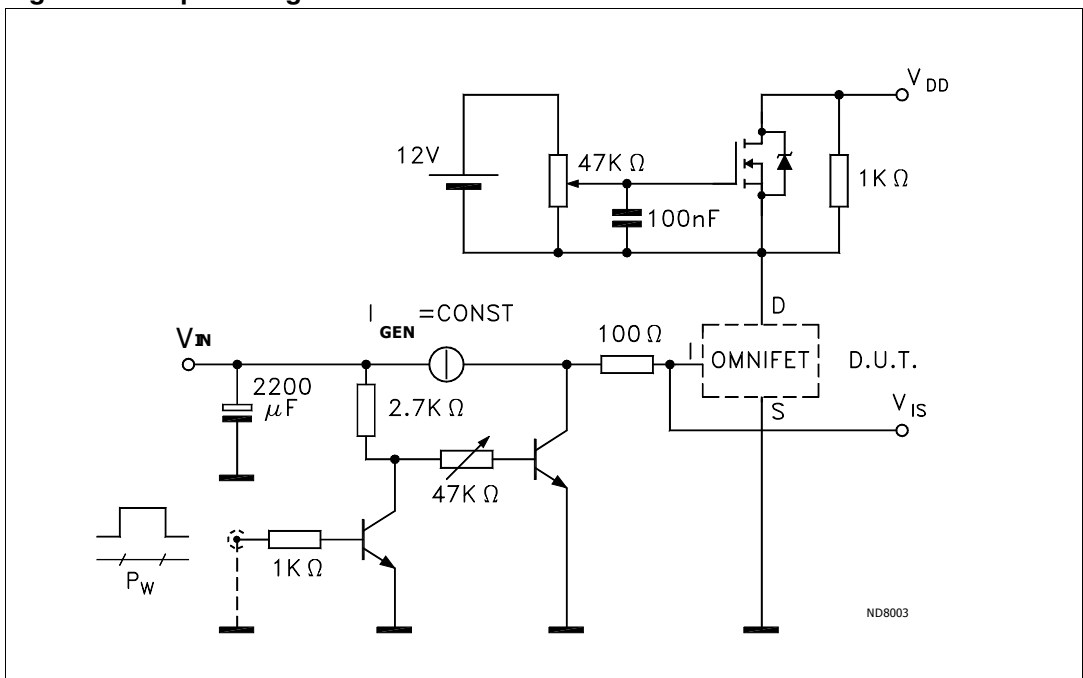

Figure 6. Unclamped inductive waveforms

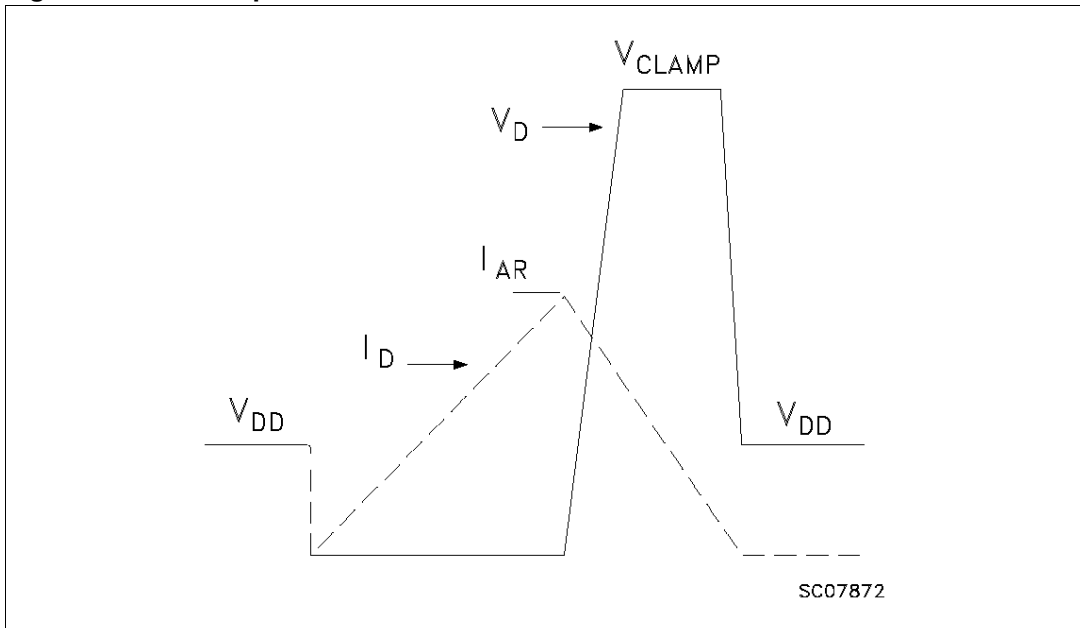

Figure 7. Switching waveforms

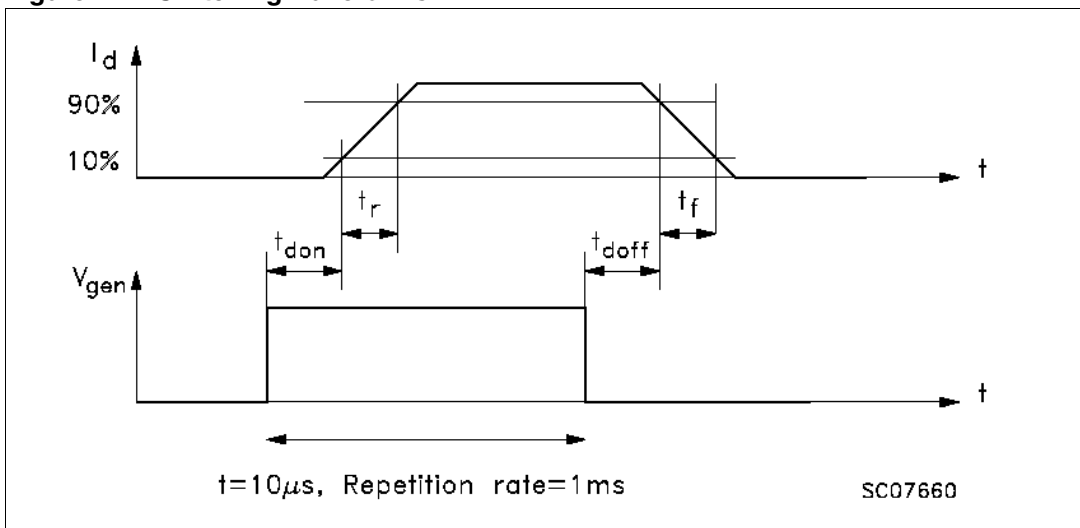

Figure 8. Thermal impedance for ISOWATT220

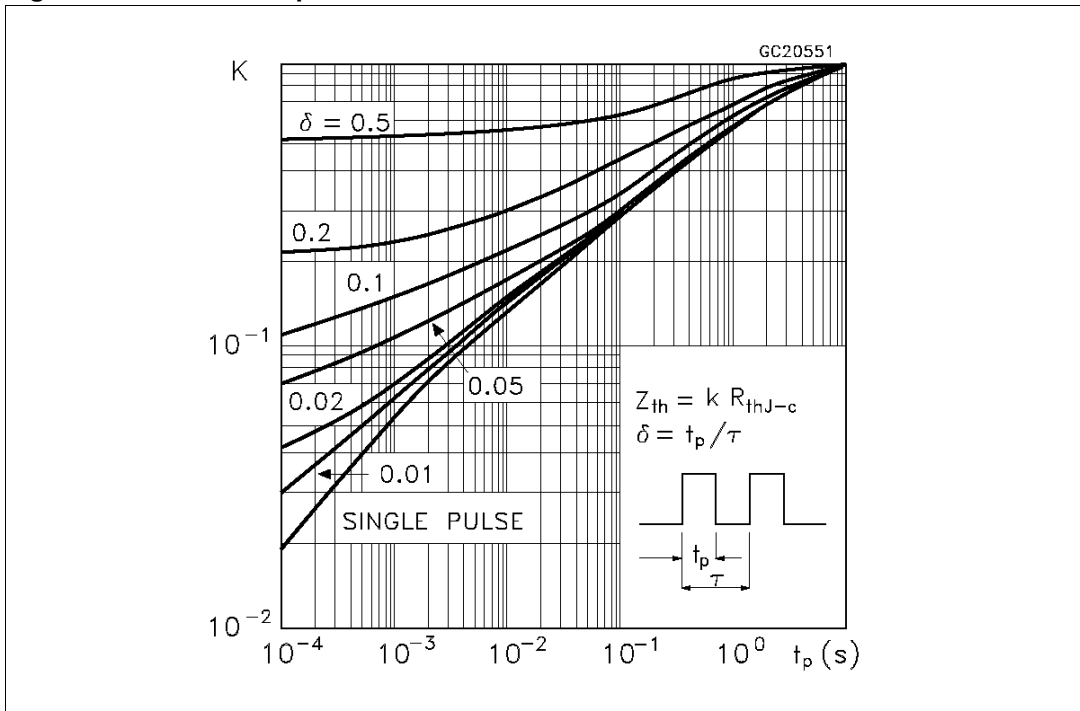
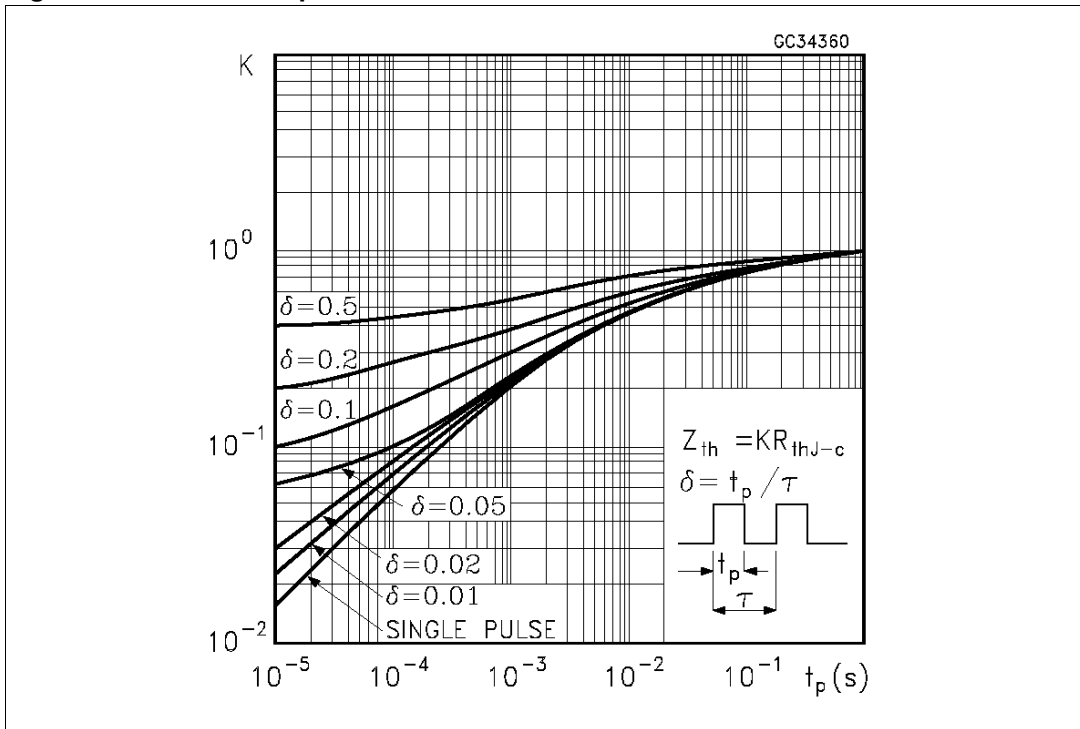

Figure 9. Thermal impedance for DPAK / IPAK



2.4 Electrical characteristics curves

Figure 10. Source-Drain diode forward characteristics

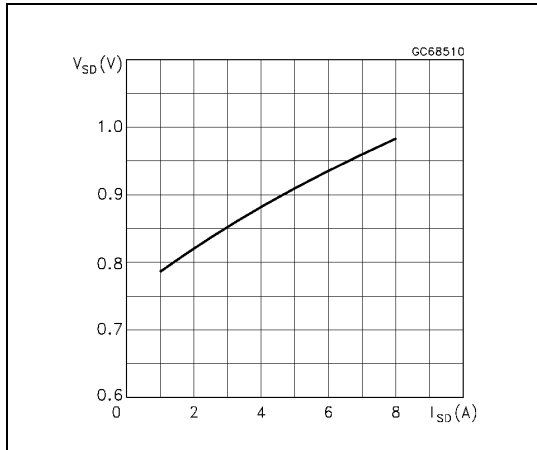

Figure 11. Static Drain-Source on resistance

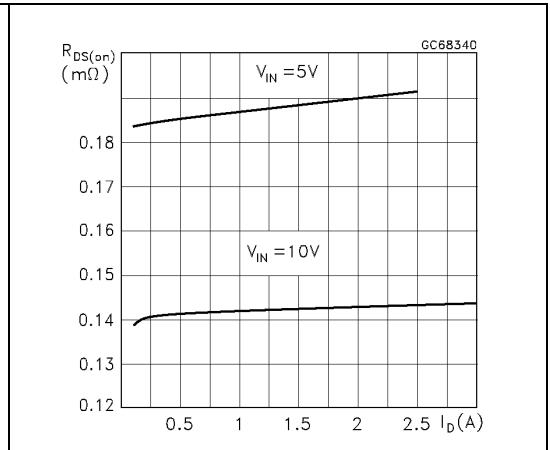

Figure 12. Derating curve

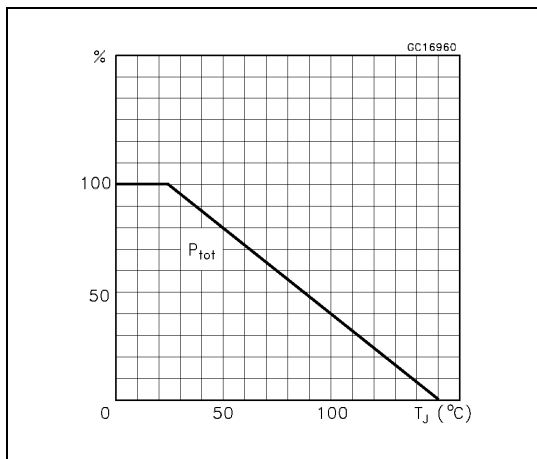

Figure 13. Static Drain-Source on resistance vs. input voltage

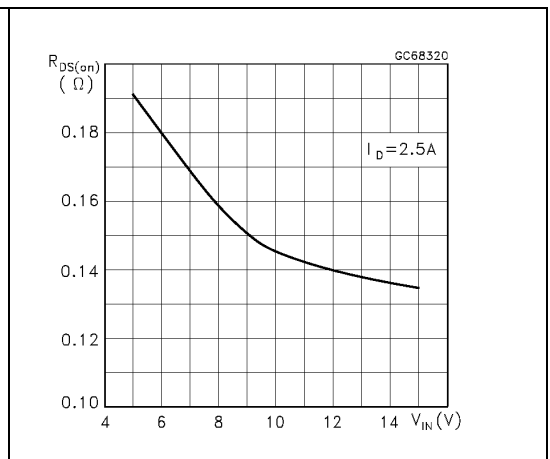

Figure 14. Normalized on resistance Vs temperature

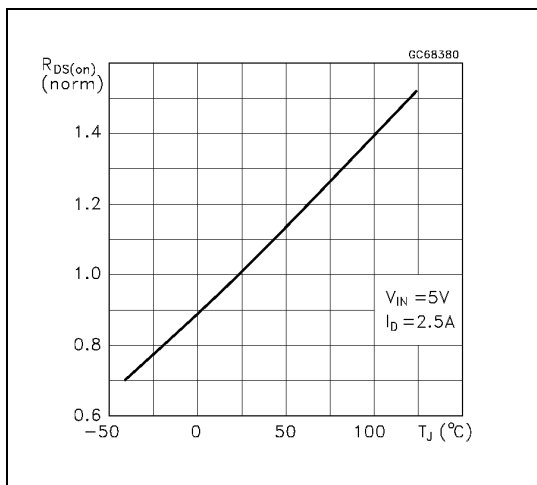

Figure 15. Transconductance

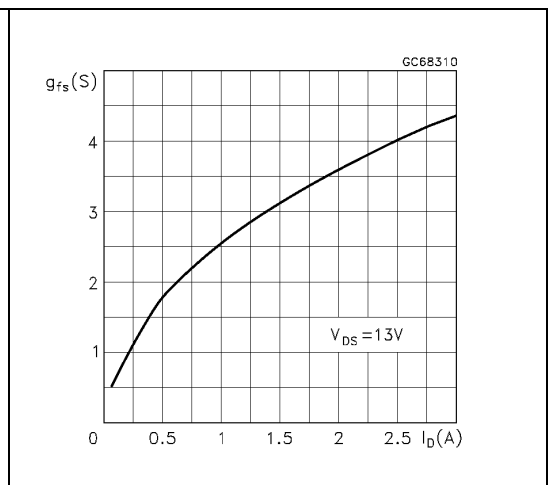

Figure 16. Static Drain-Source on resistance Vs. Id

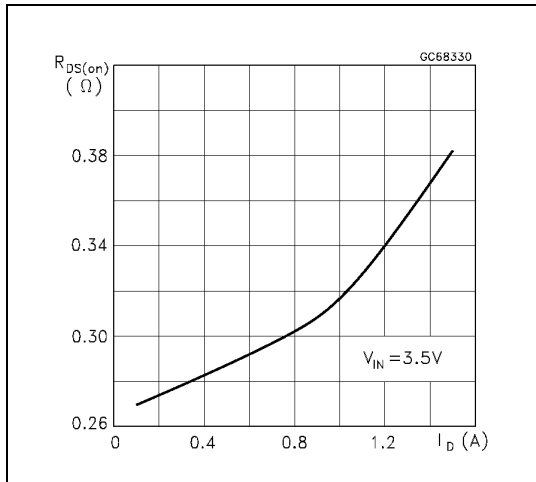

Figure 17. Switching time resistive load

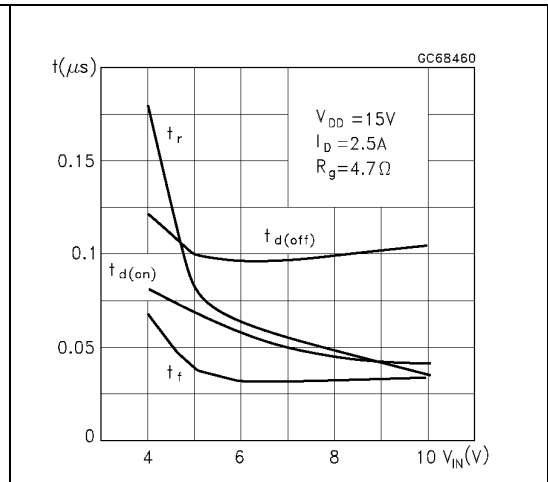

Figure 18. Turn-on current slope (V_IN = 10V)

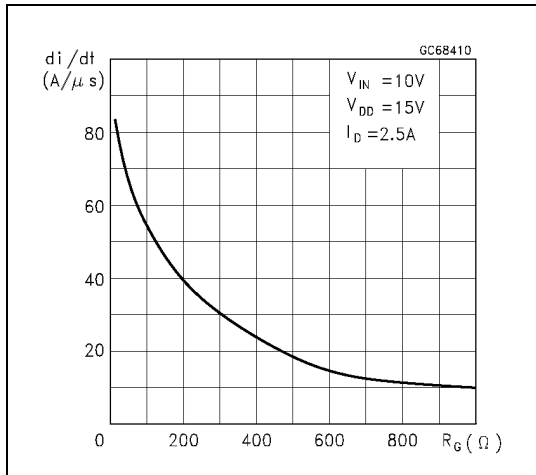

Figure 19. Turn-on current slope (V_IN = 5V)

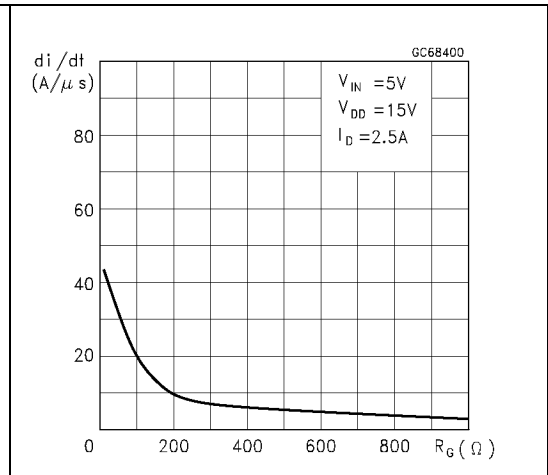

Figure 20. Input voltage Vs. input charge

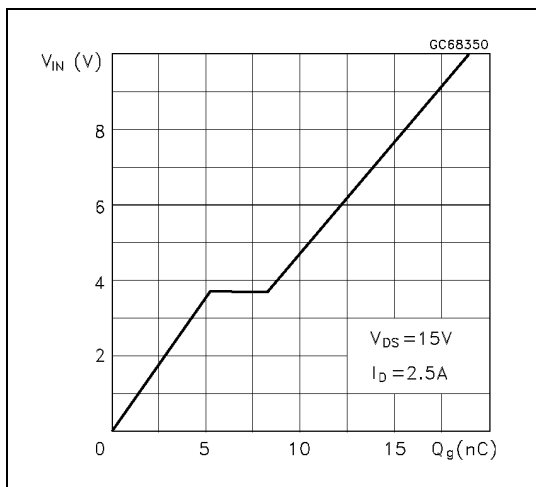

Figure 21. Turn-off Drain Source voltage slope

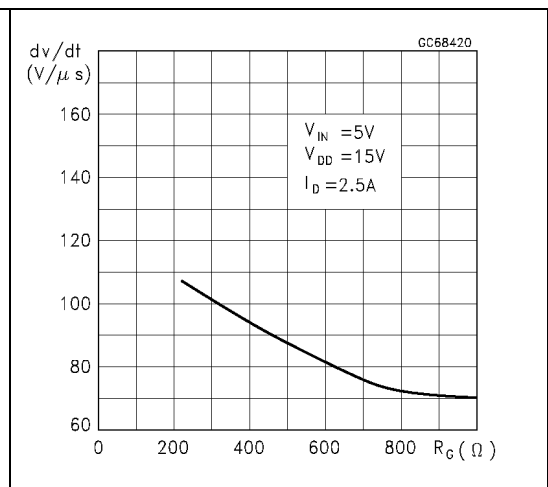

Figure 22. Turn-off Drain-Source voltage slope **Figure 23. Capacitance variations**

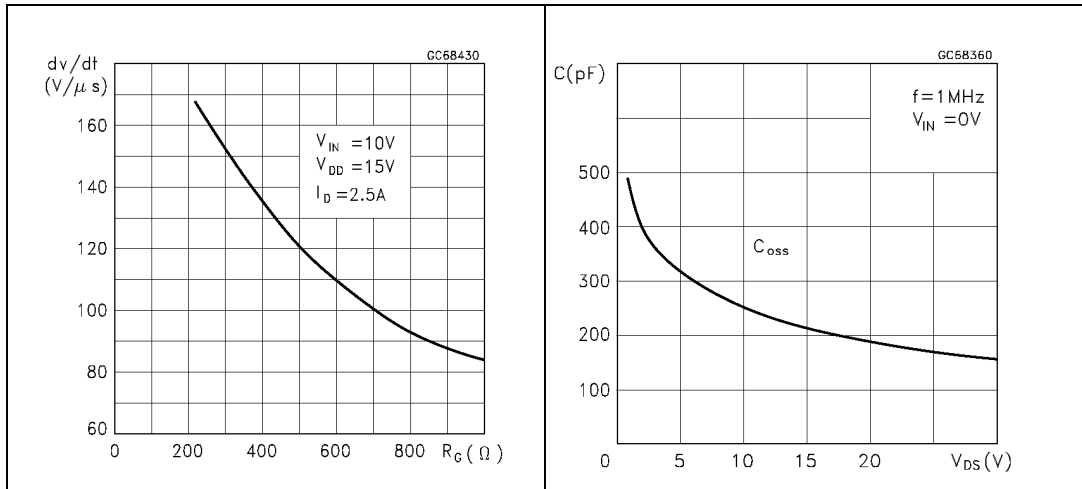

Figure 24. Switching time resistive load **Figure 25. Step response current limit**

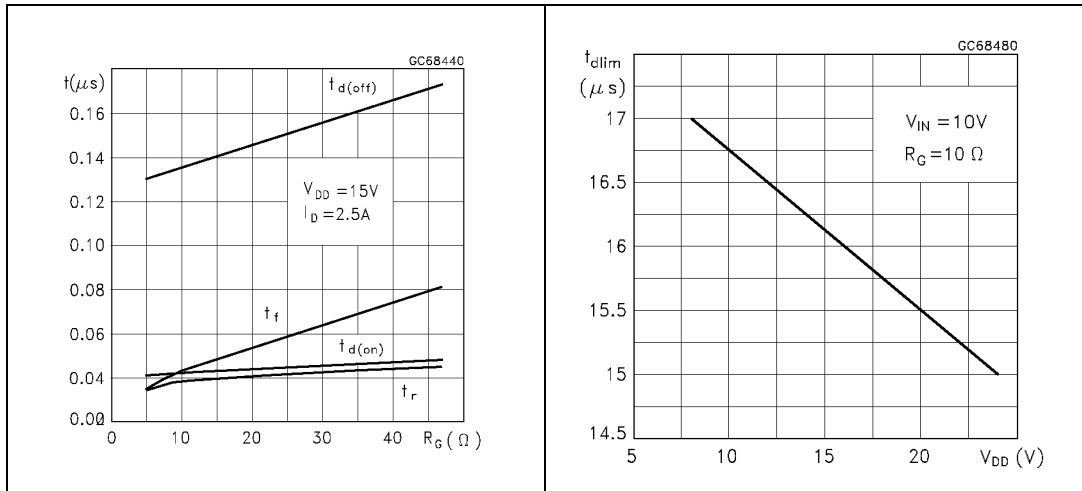

Figure 26. Output characteristics

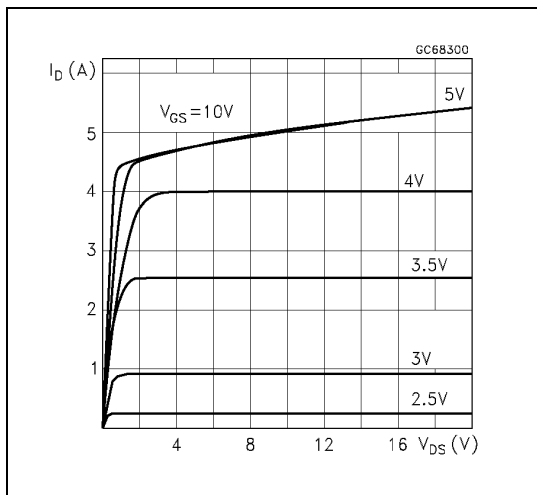

Figure 27. Normalized on resistance Vs. temperature

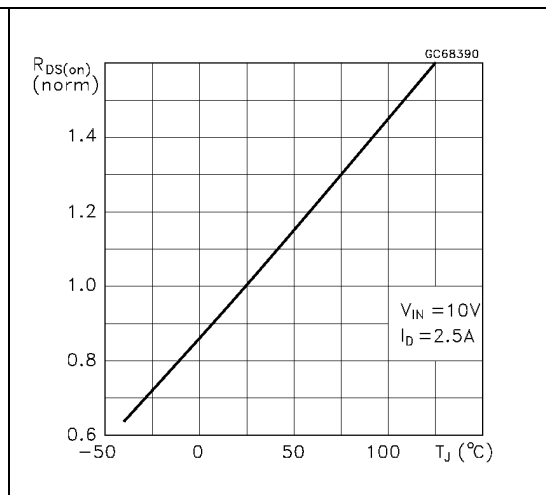

Figure 28. Normalized Input threshold voltage Vs. temperature

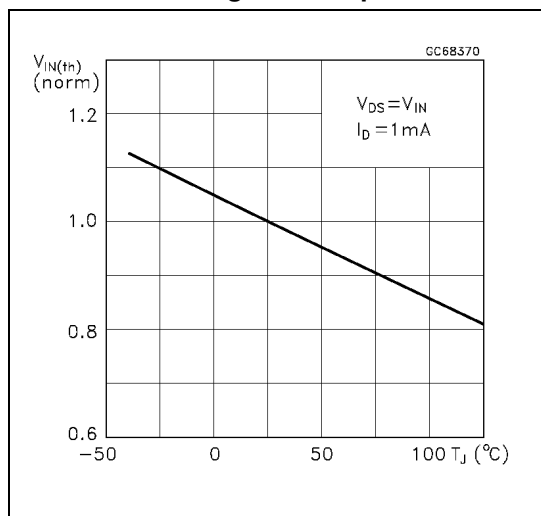
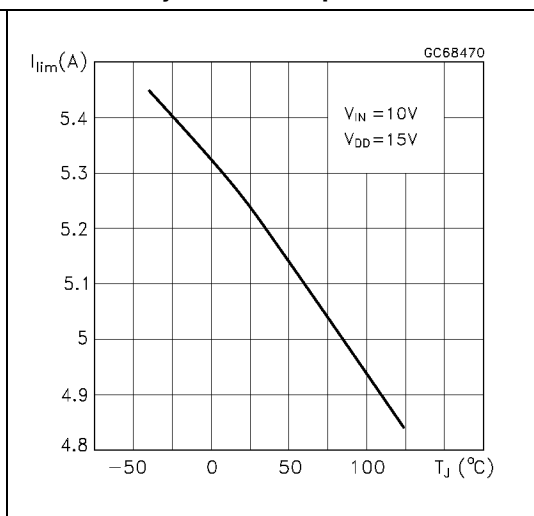

Figure 29. Normalized current limit Vs. junction temperature



3 Protection features

During normal operation, the INPUT pin is electrically connected to the gate of the internal power MOSFET.

The device then behaves like a standard power MOSFET and can be used as a switch from DC to 50KHz. The only difference from the user's standpoint is that a small DC current I_{ISS} flows into the INPUT pin in order to supply the internal circuitry.

The device integrates:

3.1 Overvoltage clamp protection

Internally set at 70V, along with the rugged avalanche characteristics of the Power MOSFET stage give this device unrivalled ruggedness and energy handling capability. This feature is mainly important when driving inductive loads.

3.2 Linear current limiter circuit

Limits the drain current I_D to I_{lim} whatever the INPUT pin voltages. When the current limiter is active, the device operates in the linear region, so power dissipation may exceed the capability of the heatsink. Both case and junction temperatures increase, and if this phase lasts long enough, junction temperature may reach the overtemperature threshold T_{jsh} .

3.3 Overtemperature and short circuit protection

These are based on sensing the chip temperature and are not dependent on the input voltage. The location of the sensing element on the chip in the power stage area ensures fast, accurate detection of the junction temperature. Overtemperature cutout occurs at minimum 150 °C. The device is automatically restarted when the chip temperature falls below 135 °C .

3.4 Status feedback

In the case of an overtemperature fault condition, a Status Feedback is provided through the Input pin. The internal protection circuit disconnects the input from the gate and connects it instead to ground via an equivalent resistance of 100 Ω . The failure can be detected by monitoring the voltage at the Input pin, which will be close to ground potential.

Additional features of this device are ESD protection according to the Human Body model and the ability to be driven from a TTL Logic circuit (with a small increase in $R_{DS(on)}$).

4 Package and packing information

4.1 ECOPACK® packages

In order to meet environmental requirements, ST offers these devices in different grades of ECOPACK® packages, depending on their level of environmental compliance. ECOPACK® specifications, grade definitions and product status are available at: www.st.com. ECOPACK® is an ST trademark.

4.2 DPAK mechanical data

Figure 30. DPAK package dimensions

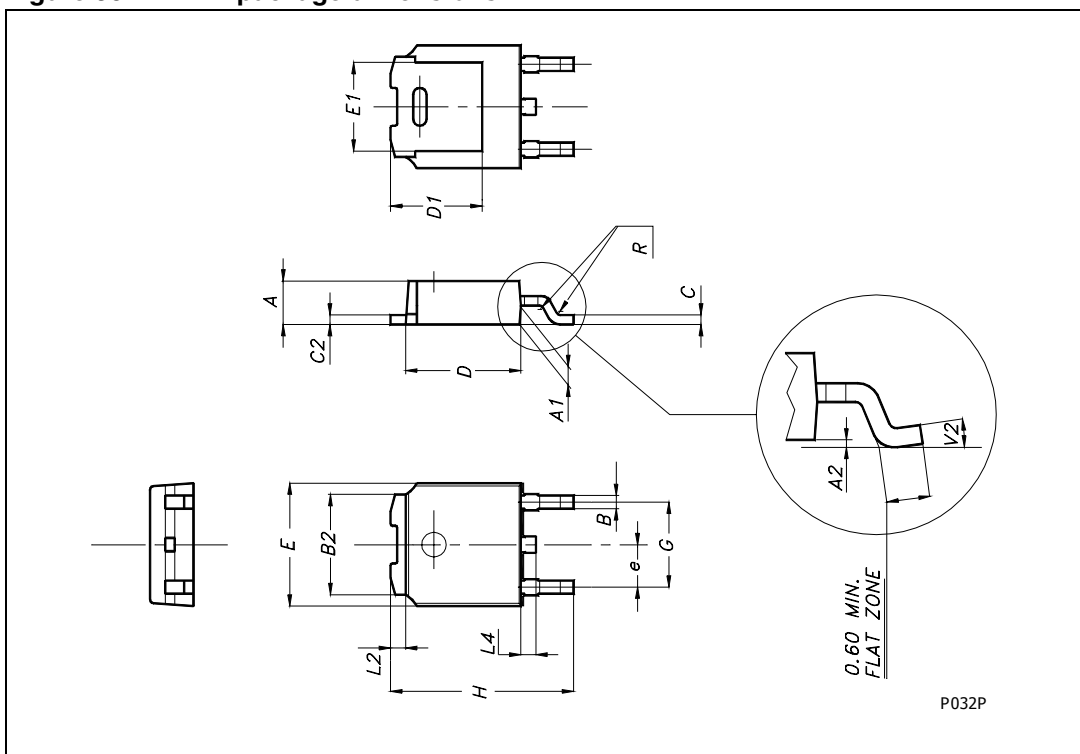

Table 10. DPAK mechanical data

| Dim. | mm | | |
|----------------|----------|------|-------|
| | Min. | Typ. | Max. |
| A | 2.20 | | 2.40 |
| A1 | 0.90 | | 1.10 |
| A2 | 0.03 | | 0.23 |
| B | 0.64 | | 0.90 |
| B2 | 5.20 | | 5.40 |
| C | 0.45 | | 0.60 |
| C2 | 0.48 | | 0.60 |
| D | 6.00 | | 6.20 |
| D1 | | 5.1 | |
| E | 6.40 | | 6.60 |
| E1 | | 4.7 | |
| e | | 2.28 | |
| G | 4.40 | | 4.60 |
| H | 9.35 | | 10.10 |
| L2 | | 0.8 | |
| L4 | 0.60 | | 1.00 |
| R | | 0.2 | |
| V2 | 0° | 8° | |
| Package weight | Gr. 0.29 | | |

4.3 IPAK mechanical data

Figure 31. IPAK mechanical data and package outline

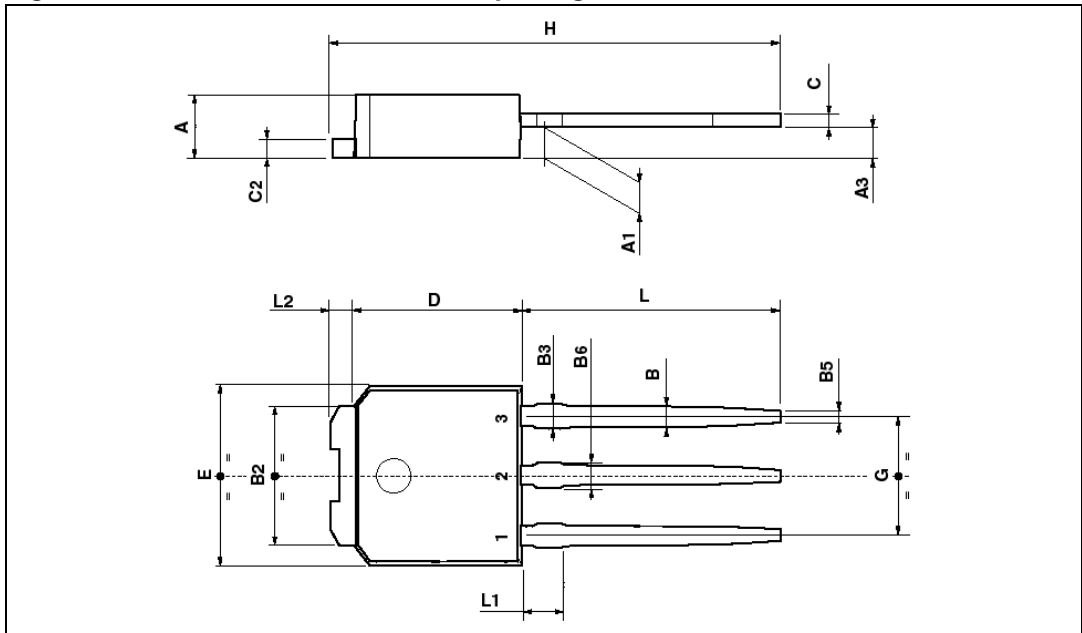

Table 11. IPAK mechanical data

| Symbol | mm | | |
|--------|------|------|------|
| | Min. | Typ. | Max. |
| A | 2.2 | | 2.4 |
| A1 | 0.9 | | 1.1 |
| A3 | 0.7 | | 1.3 |
| B | 0.64 | | 0.9 |
| B2 | 5.2 | | 5.4 |
| B3 | | | 0.85 |
| B5 | | 0.3 | |
| B6 | | | 0.95 |
| C | 0.45 | | 0.6 |
| C2 | 0.48 | | 0.6 |
| D | 6 | | 6.2 |
| E | 6.4 | | 6.6 |
| G | 4.4 | | 4.6 |
| H | 15.9 | | 16.3 |
| L | 9 | | 9.4 |
| L1 | 0.8 | | 1.2 |
| L2 | | 0.8 | 1 |

4.4 ISOWATT220 mechanical data

Figure 32. ISOWATT220 mechanical data and package outline

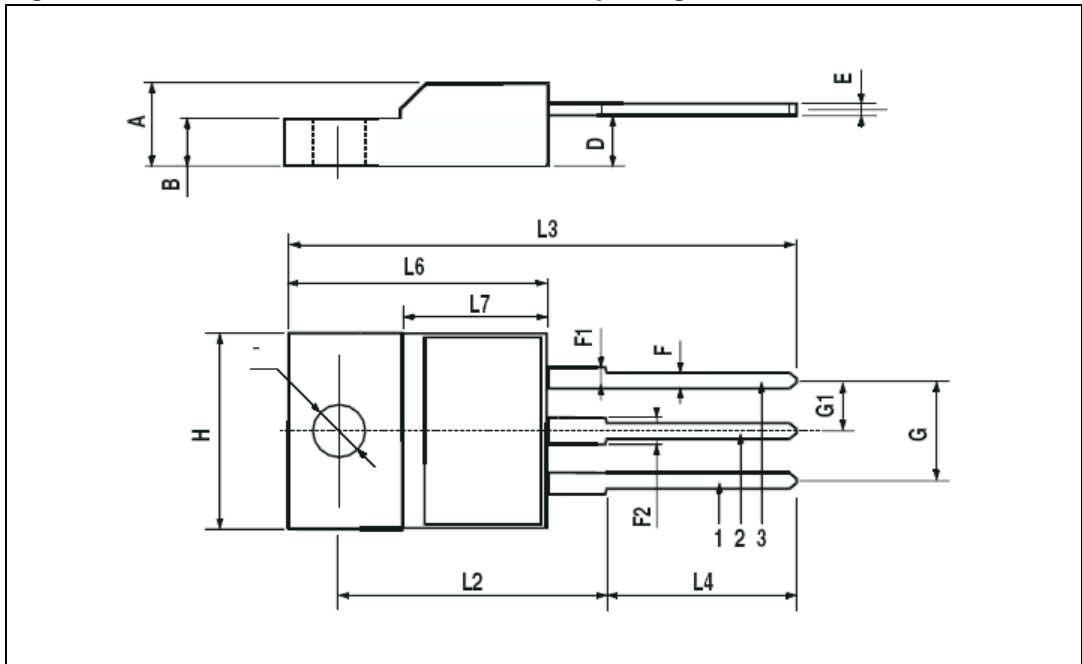

Table 12. ISOWATT220 mechanical data

| Symbol | mm | | |
|--------|------|------|------|
| | Min. | Typ. | Max. |
| A | 4.4 | | 4.6 |
| B | 2.5 | | 2.7 |
| D | 2.5 | | 2.75 |
| E | 0.4 | | 0.7 |
| F | 0.75 | | 1 |
| F1 | 1.15 | | 1.7 |
| F2 | 1.15 | | 1.7 |
| G | 4.95 | | 5.2 |
| G1 | 2.4 | | 2.7 |
| H | 10 | | 10.4 |
| L2 | | 16 | |
| L3 | 28.6 | | 30.6 |
| L4 | 9.8 | | 10.6 |
| L6 | 15.9 | | 16.4 |
| L7 | 9 | | 9.3 |
| | 3 | | 3.2 |

4.5 SOT-82FM mechanical data

Figure 33. SOT-82FM mechanical data and package outline

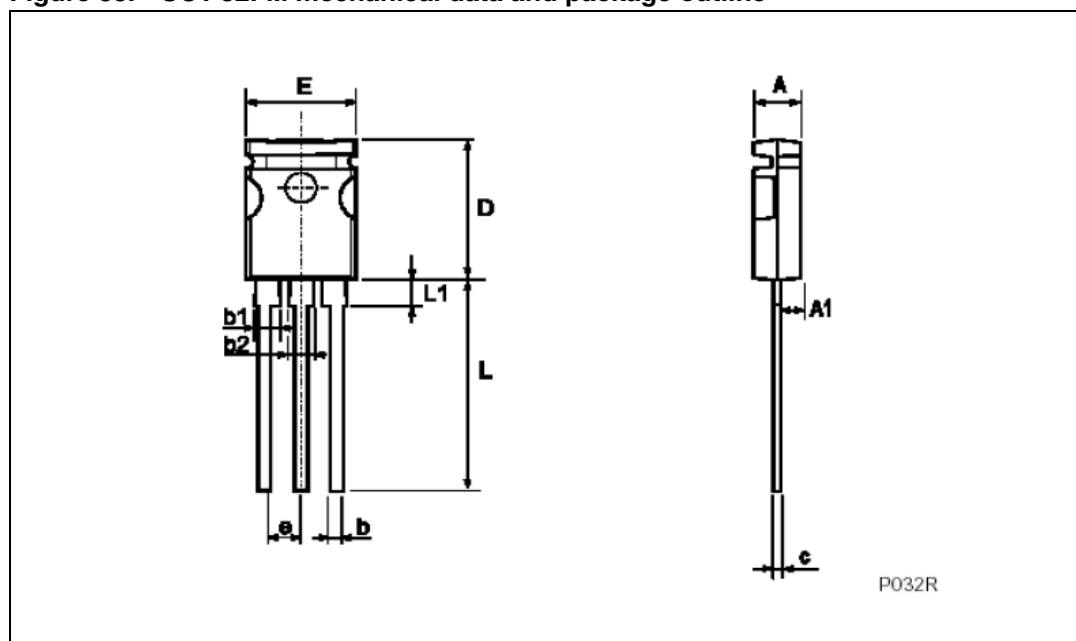

Table 13. SOT-82FM mechanical data

| Symbol | mm | | |
|--------|--------|------|------|
| | Min. | Typ. | Max. |
| A | 2.85 | | 3.05 |
| A1 | 1.47 | | 1.67 |
| b | 0.40 | | 0.60 |
| b1 | 1.4 | | 1.6 |
| b2 | 1.3 | | 1.5 |
| c | 0.45 | | 0.6 |
| D | 10.5 | | 10.9 |
| e | 2.2 | | 2.8 |
| E | 7.45 | | 7.75 |
| L | 15.5 | | 15.9 |
| L | 1 1.95 | | 2.35 |

5 Revision history

Table 14. Document revision history

| Date | Revision | Changes |
|-------------|----------|--|
| 09-Sep-2004 | 1 | Initial release. |
| 17-Dec-2007 | 2 | Stylesheet update. No content change. |
| 11-Dec-2008 | 3 | Document restructured and reformatted. Added <i>ECOPACK[®] packages</i> information. |

Please Read Carefully:

Information in this document is provided solely in connection with ST products. STMicroelectronics NV and its subsidiaries ("ST") reserve the right to make changes, corrections, modifications or improvements, to this document, and the products and services described herein at any time, without notice.

All ST products are sold pursuant to ST's terms and conditions of sale.

Purchasers are solely responsible for the choice, selection and use of the ST products and services described herein, and ST assumes no liability whatsoever relating to the choice, selection or use of the ST products and services described herein.

No license, express or implied, by estoppel or otherwise, to any intellectual property rights is granted under this document. If any part of this document refers to any third party products or services it shall not be deemed a license grant by ST for the use of such third party products or services, or any intellectual property contained therein or considered as a warranty covering the use in any manner whatsoever of such third party products or services or any intellectual property contained therein.

UNLESS OTHERWISE SET FORTH IN ST'S TERMS AND CONDITIONS OF SALE ST DISCLAIMS ANY EXPRESS OR IMPLIED WARRANTY WITH RESPECT TO THE USE AND/OR SALE OF ST PRODUCTS INCLUDING WITHOUT LIMITATION IMPLIED WARRANTIES OF MERCHANTABILITY, FITNESS FOR A PARTICULAR PURPOSE (AND THEIR EQUIVALENTS UNDER THE LAWS OF ANY JURISDICTION), OR INFRINGEMENT OF ANY PATENT, COPYRIGHT OR OTHER INTELLECTUAL PROPERTY RIGHT.

UNLESS EXPRESSLY APPROVED IN WRITING BY AN AUTHORIZED ST REPRESENTATIVE, ST PRODUCTS ARE NOT RECOMMENDED, AUTHORIZED OR WARRANTED FOR USE IN MILITARY, AIR CRAFT, SPACE, LIFE SAVING, OR LIFE SUSTAINING APPLICATIONS, NOR IN PRODUCTS OR SYSTEMS WHERE FAILURE OR MALFUNCTION MAY RESULT IN PERSONAL INJURY, DEATH, OR SEVERE PROPERTY OR ENVIRONMENTAL DAMAGE. ST PRODUCTS WHICH ARE NOT SPECIFIED AS "AUTOMOTIVE GRADE" MAY ONLY BE USED IN AUTOMOTIVE APPLICATIONS AT USER'S OWN RISK.

Resale of ST products with provisions different from the statements and/or technical features set forth in this document shall immediately void any warranty granted by ST for the ST product or service described herein and shall not create or extend in any manner whatsoever, any liability of ST.

ST and the ST logo are trademarks or registered trademarks of ST in various countries.

Information in this document supersedes and replaces all information previously supplied.

The ST logo is a registered trademark of STMicroelectronics. All other names are the property of their respective owners.

© 2008 STMicroelectronics - All rights reserved

STMicroelectronics group of companies

Australia - Belgium - Brazil - Canada - China - Czech Republic - Finland - France - Germany - Hong Kong - India - Israel - Italy - Japan - Malaysia - Malta - Morocco - Singapore - Spain - Sweden - Switzerland - United Kingdom - United States of America

www.st.com