

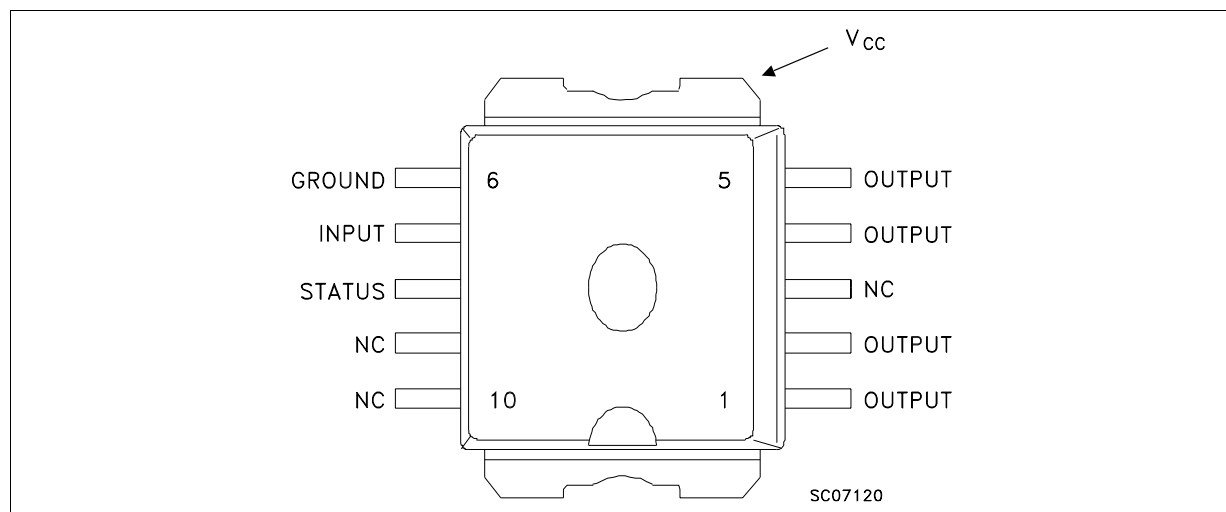


# VN31SP

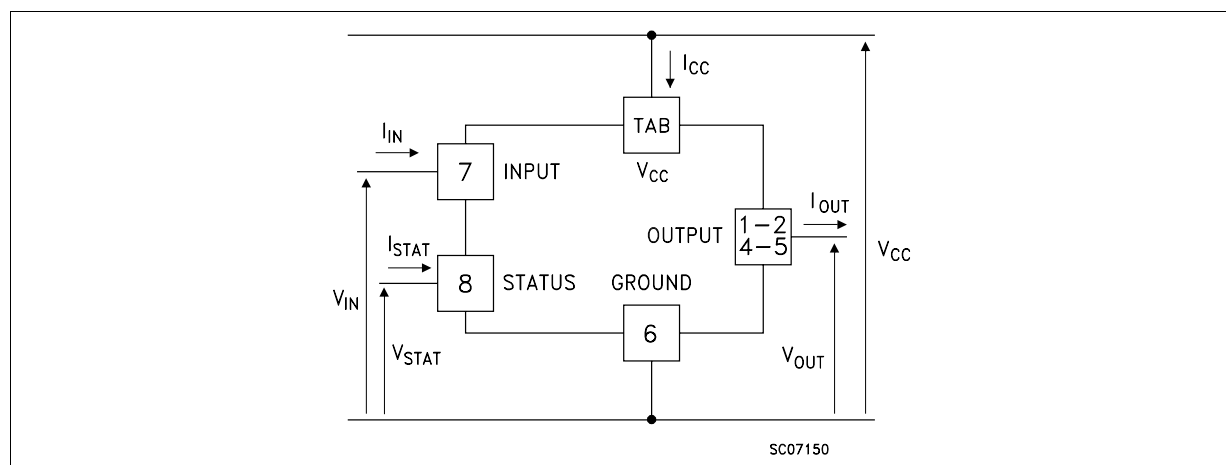
## ABSOLUTE MAXIMUM RATING

Symbol	Parameter	Value	Unit
$V_{(BR)DSS}$	Drain-Source Breakdown Voltage	60	V
$I_{OUT}$	Output Current (cont.) at $T_c = 85\text{ }^\circ\text{C}$	31	A
$I_R$	Reverse Output Current at $T_c = 85\text{ }^\circ\text{C}$	-31	A
$I_{IN}$	Input Current	$\pm 10$	mA
$-V_{CC}$	Reverse Supply Voltage	-4	V
$I_{STAT}$	Status Current	$\pm 10$	mA
$V_{ESD}$	Electrostatic Discharge (1.5 k $\Omega$ , 100 pF)	2000	V
$P_{tot}$	Power Dissipation at $T_c = 85\text{ }^\circ\text{C}$	54	W
$T_j$	Junction Operating Temperature	-40 to 150	$^\circ\text{C}$
$T_{stg}$	Storage Temperature	-55 to 150	$^\circ\text{C}$

## CONNECTION DIAGRAMS



## CURRENT AND VOLTAGE CONVENTIONS



## THERMAL DATA

$R_{thj-case}$	Thermal Resistance Junction-case	Max	1.2	$^{\circ}\text{C}/\text{W}$
$R_{thj-amb}$	Thermal Resistance Junction-ambient (\$)	Max	50	$^{\circ}\text{C}/\text{W}$

(\$) When mounted using minimum recommended pad size on FR-4 board

ELECTRICAL CHARACTERISTICS ( $V_{CC} = 13\text{ V}$ ;  $-40 \leq T_j \leq 125\text{ }^{\circ}\text{C}$  unless otherwise specified)

## POWER

Symbol	Parameter	Test Conditions	Min.	Typ.	Max.	Unit
$V_{CC}$	Supply Voltage		5.5	13	26	V
$I_n$ (*)	Nominal Current	$T_c = 85\text{ }^{\circ}\text{C}$ $V_{DS(on)} \leq 0.5$ (note 1)	11.5			A
$R_{on}$	On State Resistance	$I_{OUT} = 11.5\text{ A}$ $I_{OUT} = 11.5\text{ A}$ $T_j = 25\text{ }^{\circ}\text{C}$			0.06 0.03	$\Omega$ $\Omega$
$I_s$	Supply Current	Off State $T_j \geq 25\text{ }^{\circ}\text{C}$ On State			50 15	$\mu\text{A}$ mA
$V_{DS(MAX)}$	Maximum Voltage Drop	$I_{OUT} = 25\text{ A}$ $T_c = 85\text{ }^{\circ}\text{C}$			1.5	V

## SWITCHING

Symbol	Parameter	Test Conditions	Min.	Typ.	Max.	Unit
$t_{d(on)}(\wedge)$	Turn-on Delay Time Of Output Current	$I_{OUT} = 11.5\text{ A}$ Resistive Load Input Rise Time $< 0.1\text{ }\mu\text{s}$		90		$\mu\text{s}$
$t_r(\wedge)$	Rise Time Of Output Current	$I_{OUT} = 11.5\text{ A}$ Resistive Load Input Rise Time $< 0.1\text{ }\mu\text{s}$		100		$\mu\text{s}$
$t_{d(off)}(\wedge)$	Turn-off Delay Time Of Output Current	$I_{OUT} = 11.5\text{ A}$ Resistive Load Input Rise Time $< 0.1\text{ }\mu\text{s}$		140		$\mu\text{s}$
$t_f(\wedge)$	Fall Time Of Output Current	$I_{OUT} = 11.5\text{ A}$ Resistive Load Input Rise Time $< 0.1\text{ }\mu\text{s}$		50		$\mu\text{s}$
$(di/dt)_{on}$	Turn-on Current Slope	$I_{OUT} = 11.5\text{ A}$ $I_{OUT} = I_{OV}$		0.08	0.5 1	$\text{A}/\mu\text{s}$ $\text{A}/\mu\text{s}$
$(di/dt)_{off}$	Turn-off Current Slope	$I_{OUT} = 11.5\text{ A}$ $I_{OUT} = I_{OV}$		0.2	3 3	$\text{A}/\mu\text{s}$ $\text{A}/\mu\text{s}$
$V_{demag}$	Inductive Load Clamp Voltage	$I_{OUT} = 11.5\text{ A}$ $L = 1\text{ mH}$	-24	-18	-14	V

## LOGIC INPUT

Symbol	Parameter	Test Conditions	Min.	Typ.	Max.	Unit
$V_{IL}$	Input Low Level Voltage				0.8	V
$V_{IH}$	Input High Level Voltage		2		(•)	V
$V_{I(hyst.)}$	Input Hysteresis Voltage			0.5		V
$I_{IN}$	Input Current	$V_{IN} = 5\text{ V}$ $V_{IN} = 2\text{ V}$ $V_{IN} = 0.8\text{ V}$	25	250	500 250	$\mu\text{A}$ $\mu\text{A}$ $\mu\text{A}$
$V_{ICL}$	Input Clamp Voltage	$I_{IN} = 10\text{ mA}$ $I_{IN} = -10\text{ mA}$	5.5	6 -0.7	-0.3	V V

**ELECTRICAL CHARACTERISTICS** (continued)  
**PROTECTION AND DIAGNOSTICS**

Symbol	Parameter	Test Conditions	Min.	Typ.	Max.	Unit
V <sub>STAT</sub>	Status Voltage Output Low	I <sub>STAT</sub> = 1.6 mA			0.4	V
V <sub>USD</sub>	Under Voltage Shut Down			5		V
V <sub>SCL</sub>	Status Clamp Voltage	I <sub>STAT</sub> = 10 mA I <sub>STAT</sub> = -10 mA		6 -0.7		V V
I <sub>OV</sub>	Over Current	R <sub>LOAD</sub> < 10 mΩ -40 T <sub>c</sub> 125 °C		140		A
I <sub>AV</sub>	Average Current in Short Circuit	R <sub>LOAD</sub> < 10 mΩ T <sub>c</sub> = 85 °C		2.5		A
I <sub>OL</sub>	Open Load Current Level		5	600	1250	mA
T <sub>TSD</sub>	Thermal Shut-down Temperature		140			°C
T <sub>R</sub>	Reset Temperature		125			°C
V <sub>OL</sub>	Open Load Voltage Level	Off-State (note 2)	2.5	3.75	5	V
t <sub>1(on)</sub>	Open Load Filtering Time	(note 3)	1	5	10	ms
t <sub>1(off)</sub>	Open Load Filtering Time	(note 3)	1	5	10	ms
t <sub>2(off)</sub>	Open Load Filtering Time	(note 3)	1	5	10	ms
t <sub>povl</sub>	Status Delay	(note 3)		5	10	μs
t <sub>pol</sub>	Status Delay	(note 3)	50	700		μs

(^) See Switching Time Waveforms

() The V<sub>IH</sub> is internally clamped at 6V about. It is possible to connect this pin to an higher voltage via an external resistor calculated to not exceed 10 mA at the input pin.

note 1: The Nominal Current is the current at T<sub>c</sub> = 85 °C for battery voltage of 13V which produces a voltage drop of 0.5 V

note 2: I<sub>OL(off)</sub> = (V<sub>CC</sub> - V<sub>OL</sub>)/R<sub>OL</sub> (see figure)

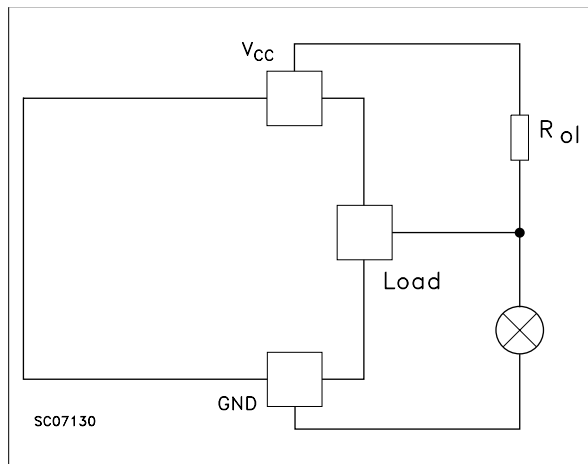
note 3: t<sub>1(on)</sub>: minimum open load duration which activates the status output

t<sub>1(off)</sub>: minimum load recovery time which deactivates the status output

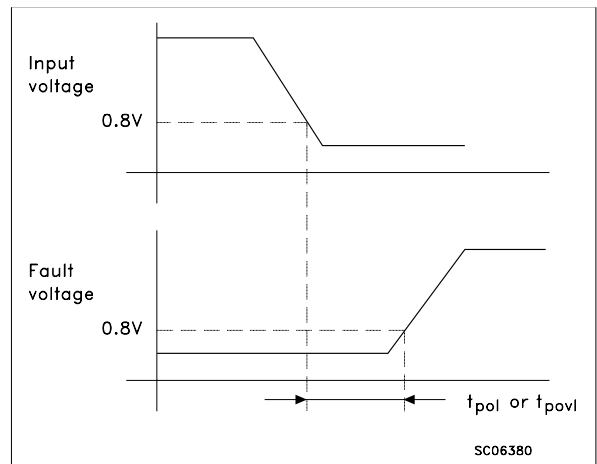
t<sub>2(off)</sub>: minimum on time after thermal shut down which deactivates status output

t<sub>povl</sub> t<sub>pol</sub>: ISO definition (see figure)

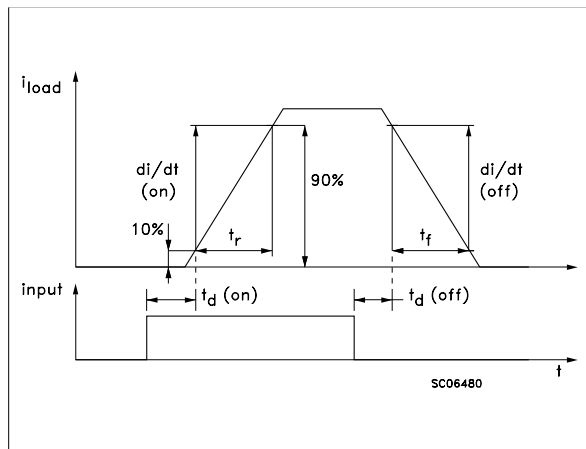
Note 2 Relevant Figure



Note 3 Relevant Figure



## Switching Time Waveforms



## FUNCTIONAL DESCRIPTION

The device has a diagnostic output which indicates open load conditions in off state as well as in on state, output shorted to  $V_{CC}$  and overtemperature. The truth table shows input, diagnostic and output voltage level in normal operation and in fault conditions. The output signals are processed by internal logic. The open load diagnostic output has a 5 ms filtering. The filter gives a continuous signal for the fault condition after an initial delay of about 5 ms. This means that a disconnection during normal operation, with a duration of less than 5 ms does not affect the status output. Equally, any re-connection of less than 5 ms during a disconnection duration does not affect the status output. No delay occur for the status to go low in case of overtemperature conditions. From the falling edge of the input signal the status output initially low in fault condition (over temperature or open load) will go back with a delay ( $t_{povl}$ ) in case of overtemperature condition and a delay ( $t_{pol}$ ) in case of open load. These feature fully comply with International Standard Office (I.S.O.) requirement for automotive High Side Driver.

To protect the device against short circuit and over current conditions, the thermal protection turns the integrated Power MOS off at a minimum junction temperature of 140 °C. When the temperature returns to 125 °C the switch is automatically turned on again. In short circuit the protection reacts with virtually no delay, the sensor being located in the region of the die where the heat is generated. Driving inductive loads, an internal function of the device ensures the fast demagnetization with a

typical voltage ( $V_{demag}$ ) of -18V.

This function allows to greatly reduce the power dissipation according to the formula:

$$P_{dem} = 0.5 \cdot L_{load} \cdot (I_{load})^2 \cdot [(V_{CC} + V_{demag}) / V_{demag}]$$

• f

where f = switching frequency and

$V_{demag}$  = demagnetization voltage

Based on this formula it is possible to know the value of inductance and/or current to avoid a thermal shut-down. The maximum inductance which causes the chip temperature to reach the shut down temperature in a specific thermal environment, is infact a function of the load current for a fixed  $V_{CC}$ ,  $V_{demag}$  and f.

## PROTECTING THE DEVICE AGAINST LOAD DUMP - TEST PULSE 5

The device is able to withstand the test pulse No. 5 at level II ( $V_s = 46.5V$ ) according to the ISO T/R 7637/1 without any external component. This means that all functions of the device are performed as designed after exposure to disturbance at level II. The VN06SP is able to withstand the test pulse No.5 at level III adding an external resistor of 150 ohm between GND pin and ground plus a filter capacitor of 1000  $\mu F$  between  $V_{CC}$  pin and ground (if  $R_{LOAD} \leq 20 \Omega$ ).

## PROTECTING THE DEVICE AGAINST REVERSE BATTERY

The simplest way to protect the device against a continuous reverse battery voltage (-26V) is to insert a Schottky diode between GND pin and ground, as shown in the typical application circuit (fig.3).

The consequences of the voltage drop across this diode are as follows:

If the input is pulled to power GND, a negative voltage of  $-V_f$  is seen by the device. ( $V_{il}$ ,  $V_{ih}$  thresholds and  $V_{stat}$  are increased by  $V_f$  with respect to power GND).

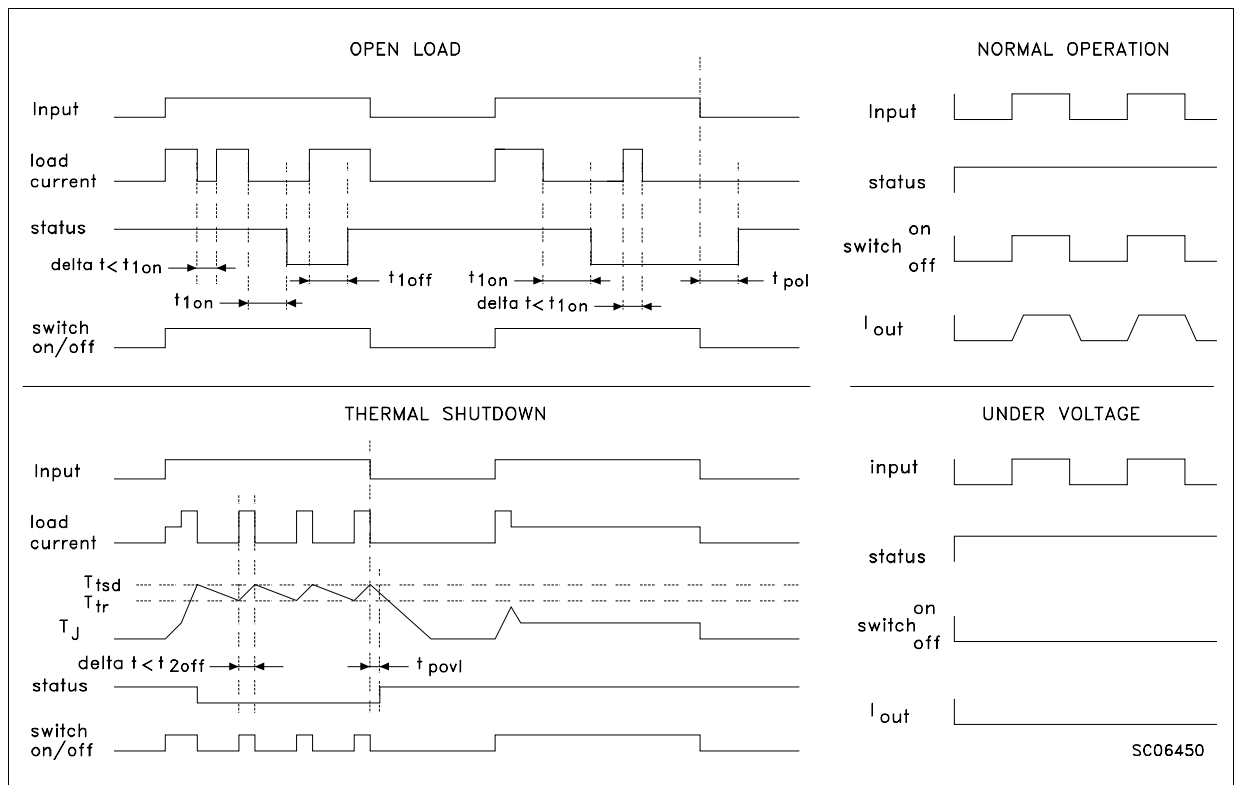
The undervoltage shutdown level is increased by  $V_f$ .

If there is no need for the control unit to handle external analog signals referred to the power GND, the best approach is to connect the reference potential of the control unit to node [6] (see application circuit in fig. 4), which becomes the common signal GND for the whole control board avoiding shift of  $V_{ih}$ ,  $V_{il}$  and  $V_{stat}$ . This solution allows the use of a standard diode.

TRUTH TABLE

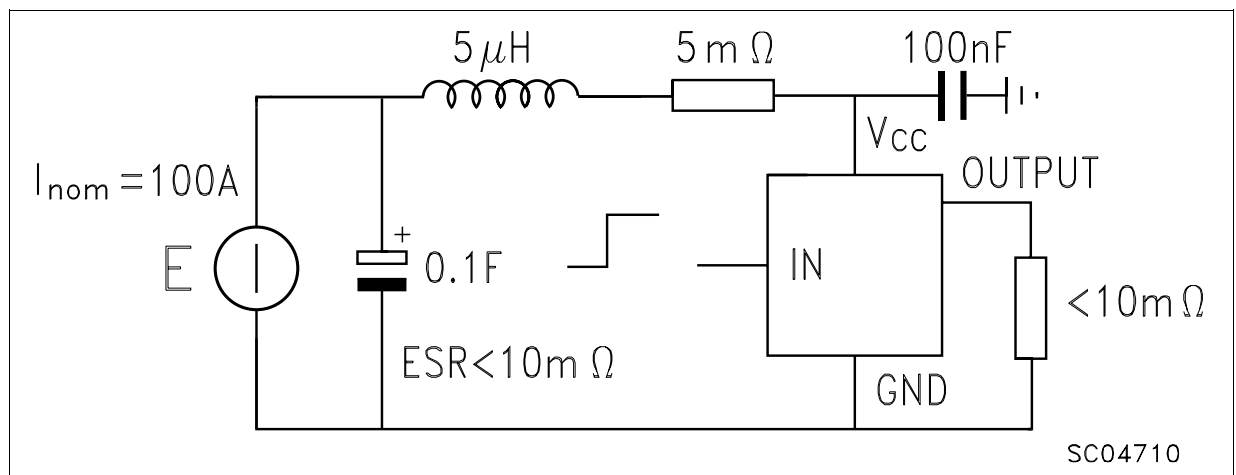
	INPUT	OUTPUT	DIAGNOSTIC
Normal Operation	L	L	H
	H	H	H
Open Circuit (No Load)	H	H	L
Over-temperature	H	L	L
Under-voltage	X	L	H
Short load to V <sub>CC</sub>	L	H	L

Figure 1: Waveforms



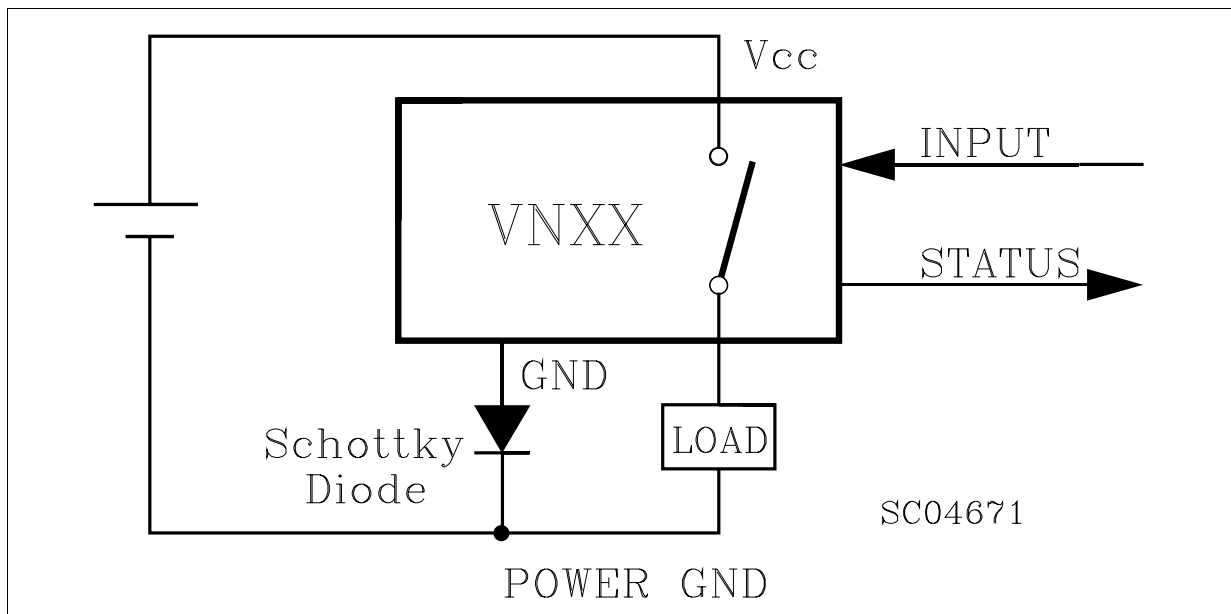
SC06450

Figure 2: Over Current Test Circuit

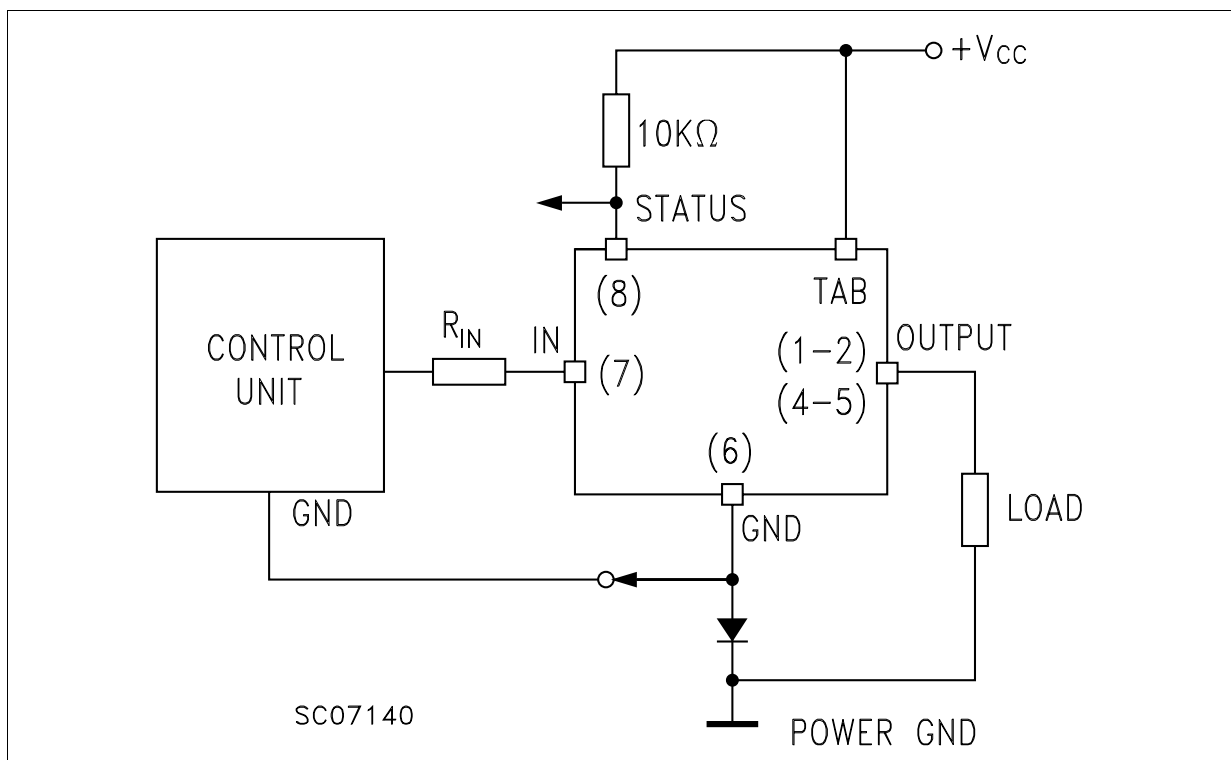


SC04710

**Figure 3:** Typical Application Circuit With A Schottky Diode For Reverse Supply Protection

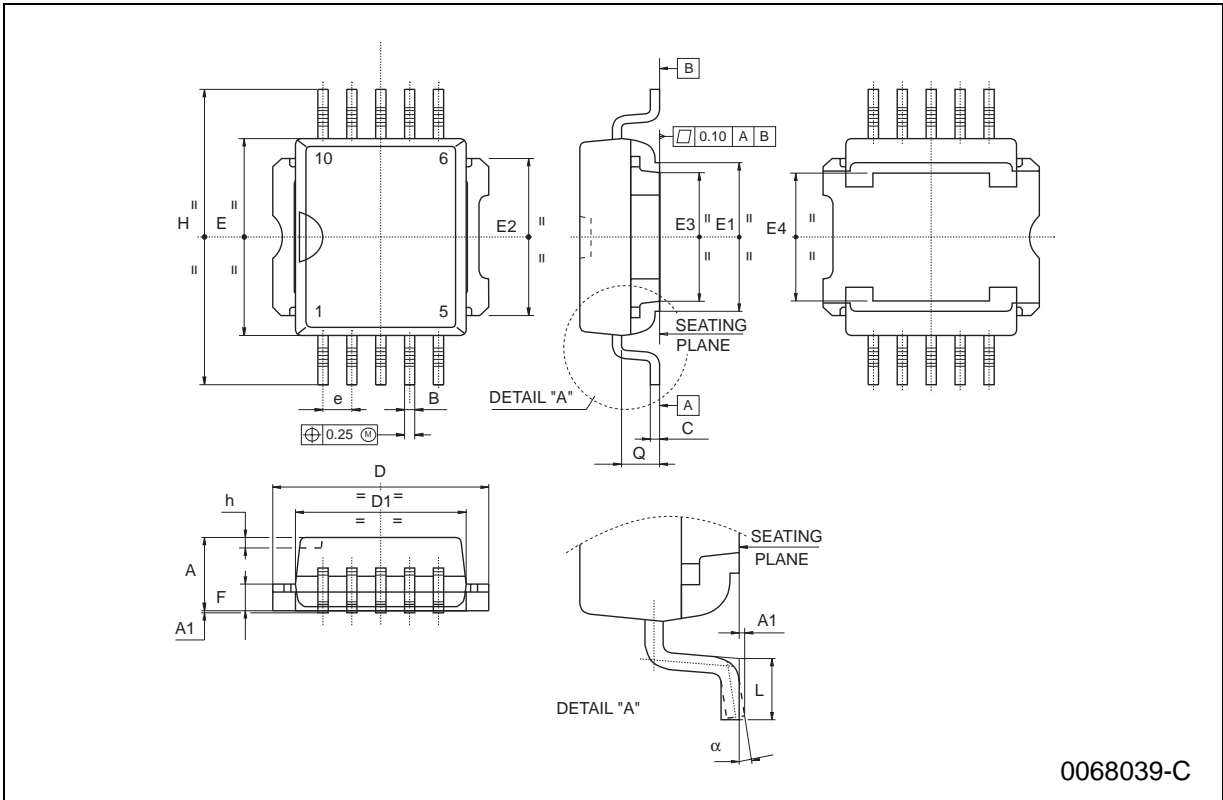


**Figure 4:** Typical Application Circuit With Separate Signal Ground



**PowerSO-10 MECHANICAL DATA**

DIM.	mm			inch		
	MIN.	TYP.	MAX.	MIN.	TYP.	MAX.
A	3.35		3.65	0.132		0.144
A1	0.00		0.10	0.000		0.004
B	0.40		0.60	0.016		0.024
c	0.35		0.55	0.013		0.022
D	9.40		9.60	0.370		0.378
D1	7.40		7.60	0.291		0.300
E	9.30		9.50	0.366		0.374
E1	7.20		7.40	0.283		0.291
E2	7.20		7.60	0.283		0.300
E3	6.10		6.35	0.240		0.250
E4	5.90		6.10	0.232		0.240
e		1.27			0.050	
F	1.25		1.35	0.049		0.053
H	13.80		14.40	0.543		0.567
h		0.50			0.002	
L	1.20		1.80	0.047		0.071
q		1.70			0.067	
$\alpha$	0°		8°			



0068039-C

Information furnished is believed to be accurate and reliable. However, STMicroelectronics assumes no responsibility for the consequences of use of such information nor for any infringement of patents or other rights of third parties which may result from its use. No license is granted by implication or otherwise under any patent or patent rights of STMicroelectronics. Specification mentioned in this publication are subject to change without notice. This publication supersedes and replaces all information previously supplied. STMicroelectronics products are not authorized for use as critical components in life support devices or systems without express written approval of STMicroelectronics.

The ST logo is a trademark of STMicroelectronics

© 1998 STMicroelectronics – Printed in Italy – All Rights Reserved

STMicroelectronics GROUP OF COMPANIES

Australia - Brazil - Canada - China - France - Germany - Italy - Japan - Korea - Malaysia - Malta - Mexico - Morocco - The Netherlands - Singapore - Spain - Sweden - Switzerland - Taiwan - Thailand - United Kingdom - U.S.A.