

Features

- High output power capability
 - 2x 20 W into 8 Ω at 17 V with 10% THD
 - 2x 18 W into 4 Ω at 12 V with 10% THD
- Minimum external components count:
 - No bootstrap capacitors
 - No Boucherot cells
 - Internally fixed gain 26 dB
- Standby function (CMOS compatible)
- No audible pop during standby operations
- Diagnostic facilities:
 - Clip detector
 - Output to ground short-circuit detector
 - Output to supply short-circuit detector
 - Soft short-circuit check at turn-on
 - Thermal shutdown warning

Protection

- Output AC/DC short circuit
- Soft short-circuit check at turn-on
- Thermal cutoff/limiter to prevent chip from overheating
- High inductive loads
- ESD

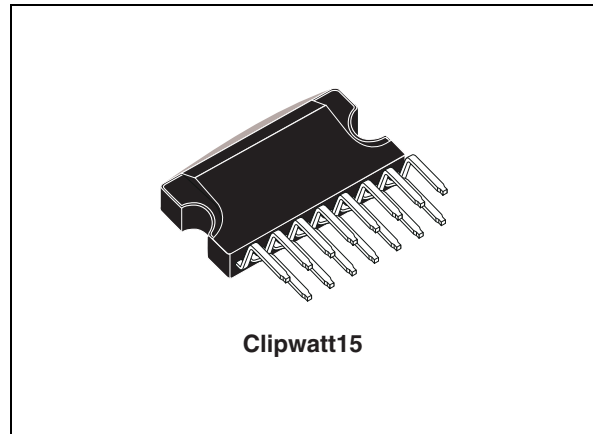

Description

The STA541SA is a dual bridge, class-AB audio amplifier designed for high quality sound applications.

The amplifiers have outputs with integrated short-circuit protection, thermal protection and diagnostic functions.

The chip is housed in the 15-pin Clipwatt, environmentally friendly, ECOPACK[®] package.

Table 1. Device summary

Order code	Operating temp. range	Package	Packaging
STA541SA	0 to 70 °C	Clipwatt15	Tube

Contents

- 1 Block diagram and pin description 6**
 - 1.1 Block diagram 6
 - 1.2 Pin description 7

- 2 Electrical specifications 8**
 - 2.1 Absolute maximum ratings 8
 - 2.2 Thermal data 8
 - 2.3 Recommended operating conditions 9
 - 2.4 Electrical characteristics 9

- 3 Characterization curves 11**
 - 3.1 For 4-Ω loads 11
 - 3.2 For 8-Ω loads 12

- 4 Applications 13**

- 5 Demonstration board 14**

- 6 Thermal information 16**
 - 6.1 Heatsink specification examples 16
 - 6.1.1 R_{th_HS} calculation 16
 - 6.1.2 Calculations using music power 16

- 7 Practical information 17**
 - 7.1 Internally fixed gain 17
 - 7.2 Silent turn on/off and muting/standby function 17
 - 7.3 Driving circuit for standby mode 17
 - 7.4 Built-in protection 18
 - 7.4.1 Diagnostic facilities (pin 10) 18
 - 7.4.2 Short-circuit protection 18
 - 7.4.3 Clipping detection 18
 - 7.4.4 Thermal shutdown 19
 - 7.5 Handling the diagnostic information 20

7.6	PCB ground layout	21
7.7	Mute function	21
8	Package mechanical data	22
9	Revision history	25

List of figures

Figure 1.	Block diagram	6
Figure 2.	Pin connection (top view)	7
Figure 3.	Output power vs supply voltage	11
Figure 4.	Quiescent current vs supply voltage	11
Figure 5.	Efficiency, device dissipation vs output power	11
Figure 6.	Total harmonic distortion vs output power	11
Figure 7.	Crosstalk vs frequency	11
Figure 8.	Output power vs supply voltage	12
Figure 9.	Quiescent current vs supply voltage	12
Figure 10.	Efficiency, device dissipation vs output power	12
Figure 11.	Total harmonic distortion vs output power	12
Figure 12.	Crosstalk vs frequency	12
Figure 13.	Power supply rejection ratio vs frequency	12
Figure 14.	Applications circuit	13
Figure 15.	Demonstration board schematic	14
Figure 16.	PCB layout	15
Figure 17.	Clipping detection waveforms	18
Figure 18.	Configuration of pin DIAG	19
Figure 19.	Fault waveforms on pin DIAG	19
Figure 20.	Waveforms	20
Figure 21.	Interface circuit diagram	20
Figure 22.	Optional mute function circuit	21
Figure 23.	Package outline	22

List of tables

Table 1.	Device summary	1
Table 2.	Pin description	7
Table 3.	Absolute maximum ratings	8
Table 4.	Thermal data	8
Table 5.	Recommended operating condition	9
Table 6.	Electrical characteristics	9
Table 7.	Package dimensions	23
Table 8.	Document revision history	25

1 Block diagram and pin description

1.1 Block diagram

Figure 1. Block diagram

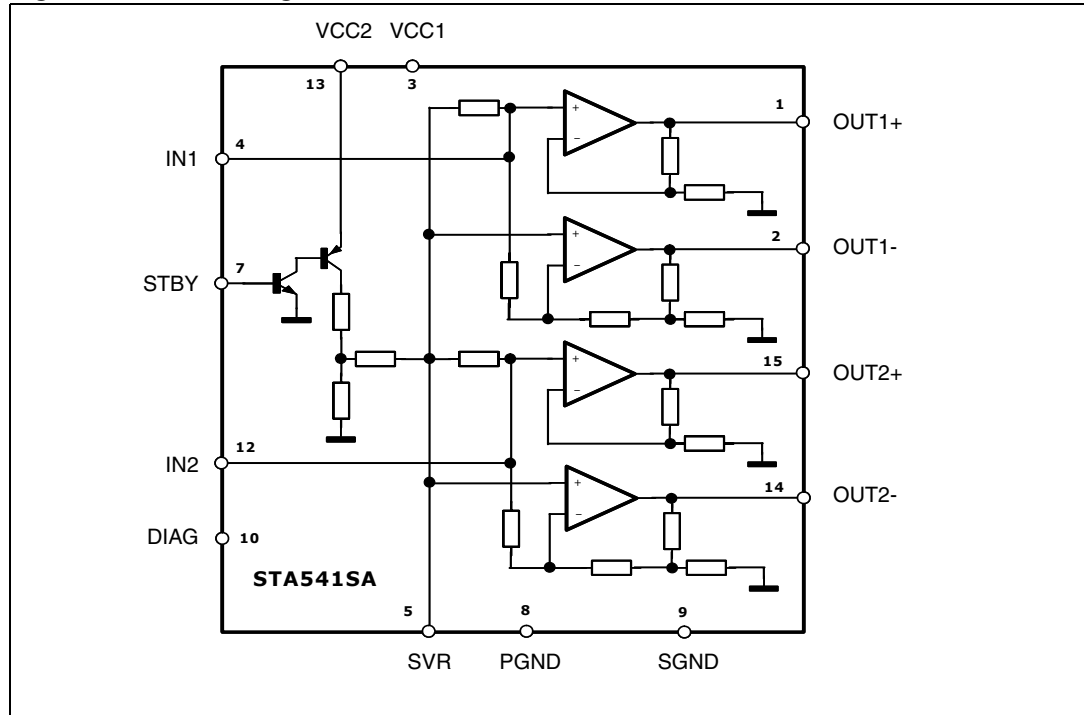

1.2 Pin description

Figure 2. Pin connection (top view)

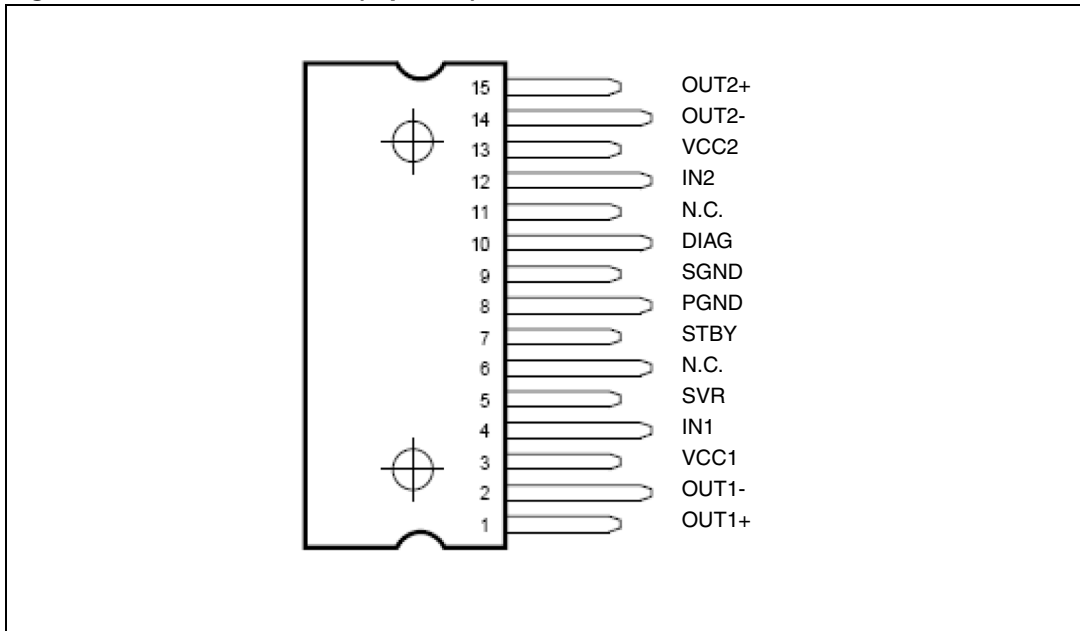

Table 2. Pin description

Pin	Name	Type	Function
1	OUT1+	OUT	Channel 1 non-inverting output
2	OUT1 -	OUT	Channel 1 inverting output
3	VCC1	PWR	Power supply
4	IN1	IN	Channel 1 input
5	SVR	IN	Supply voltage rejection
6	N.C.	-	No internal connection
7	STBY	IN	Standby control
8	PGND	PWR	Power ground
9	SGND	PWR	Signal ground
10	DIAG	OUT	Diagnostics output
11	N.C.	-	No internal connection
12	IN2	IN	Channel 2 input
13	VCC2	PWR	Power supply
14	OUT2-	OUT	Channel 2 inverting output
15	OUT2+	OUT	Channel 2 non-inverting output

2 Electrical specifications

2.1 Absolute maximum ratings

Table 3. Absolute maximum ratings

Symbol	Parameter	Min	Typ	Max	Unit
V _S	Supply voltage idle mode (no signal)	-	-	24	V
	Supply voltage operating	-	-	22	V
	Supply voltage AC-DC short safe	-	-	20	V
P _{tot}	Total power dissipation (T _{case} = 85 °C)	-	-	32	W
T _j	Junction temperature	-40	-	150	°C
T _{stg}	Storage temperature	-40	-	150	°C
T _{amb}	Ambient temperature	0	-	70	°C

Warning: Stresses beyond those listed in [Table 3](#) above may cause permanent damage to the device. These are stress ratings only, and functional operation of the device at these or any other conditions beyond those indicated under “Recommended operating conditions” are not implied. Exposure to absolute-maximum-rated conditions for extended periods may affect device reliability. In the real application, power supplies with nominal values rated within the recommended operating conditions, may rise beyond the maximum operating conditions for a short time when no or very low current is sunk (amplifier in mute state). In this case the reliability of the device is guaranteed, provided that the absolute maximum ratings are not exceeded.

2.2 Thermal data

Table 4. Thermal data

Symbol	Parameter	Min	Typ	Max	Unit
R _{th j-case}	Thermal resistance junction-case	-	-	2.5	°C/W
R _{th j-amb}	Thermal resistance junction-ambient	-	-	45	°C/W

2.3 Recommended operating conditions

Table 5. Recommended operating condition

Symbol	Parameter	Min	Typ	Max	Unit
V_S	Power supply voltage (VCC1, VCC2)	8	-	22	V
T_{amb}	Ambient temperature	0	-	70	°C

2.4 Electrical characteristics

The test conditions are $V_S = 17$ V, $R_L = 8$ Ω , $f = 1$ kHz, $T_{amb} = 25$ °C unless otherwise specified.

Table 6. Electrical characteristics

Symbol	Parameter	Test condition	Min	Typ	Max	Unit
I_d	Total quiescent drain current	-	-	80	150	mA
V_{os}	Output offset voltage	-	-150	-	150	mV
P_o	Output power	THD = 10% THD = 1%	-	20 15.6	-	W
	Output power	THD = 10%, $R_L = 4$ Ω , $V_S = 12$ V	-	18	-	W
THD	Total harmonic distortion	$P_o = 0.1$ to 4 W	-	0.02	-	%
I_{SC}	Short-circuit output current	-	3.0	3.5	-	A
C_T	Crosstalk	$f = 1$ kHz	55	70	-	dB
		$f = 10$ kHz	-	60	-	dB
R_{in}	Input impedance	-	10	15	-	k Ω
G_v	Voltage gain	-	25	26	27	dB
G_v	Voltage gain match	-	-	-	0.5	dB
E_N	Input noise voltage	$R_{gen} = 0$, $f = 22$ Hz to 22 kHz	-	3.5	-	μ V
SVR	Supply voltage rejection	$R_{gen} = 0$, $f = 300$ Hz, $C_{SVR} = 470$ μ F	50	-	-	dB
A_{STBY}	Standby attenuation	$P_o = 1$ W	80	90	-	dB
I_{STBY}	Current consumption in standby	$V_{STBY} = 0$ to 1.5 V	-	-	100	μ A
V_{SB}	ST_BY IN threshold voltage	-	-	-	1.5	V
	ST_BY OUT threshold voltage	-	3.5	-	-	V

Table 6. Electrical characteristics (continued)

Symbol	Parameter	Test condition	Min	Typ	Max	Unit
I_{STBY}	Pin ST-BY current	Play mode, $V_{STBY} = 5\text{ V}$	-	-	50	μA
		Max driving current under fault	-	-	5	mA
I_{cd_off}	Clipping detector output average current	THD = 1%	-	90	-	μA
I_{cd_on}	Clipping detector output average current	THD = 5%	-	160	-	μA
V_{DIAG}	Saturation voltage on pin DIAG	$I_{DIAG} = 1\text{ mA}$ sinking	-	-	0.7	V
T_W	Thermal warning	-	-	140	-	$^{\circ}\text{C}$
T_M	Thermal muting	-	-	150	-	$^{\circ}\text{C}$
T_S	Thermal shutdown	-	-	160	-	$^{\circ}\text{C}$

3 Characterization curves

3.1 For 4-Ω loads

Figure 3. Output power vs supply voltage

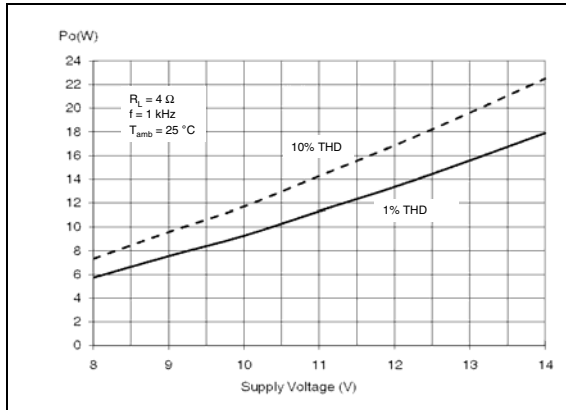

Figure 4. Quiescent current vs supply voltage

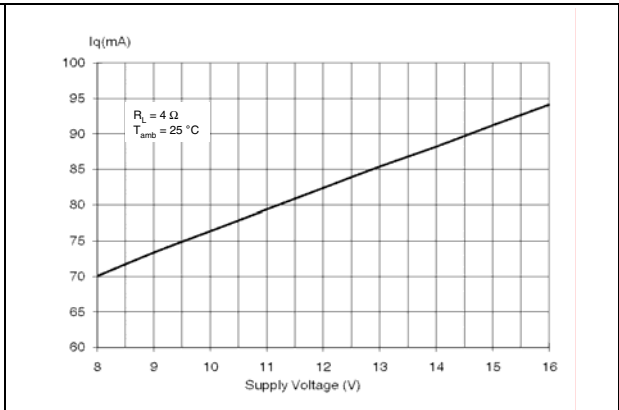

Figure 5. Efficiency, device dissipation vs output power

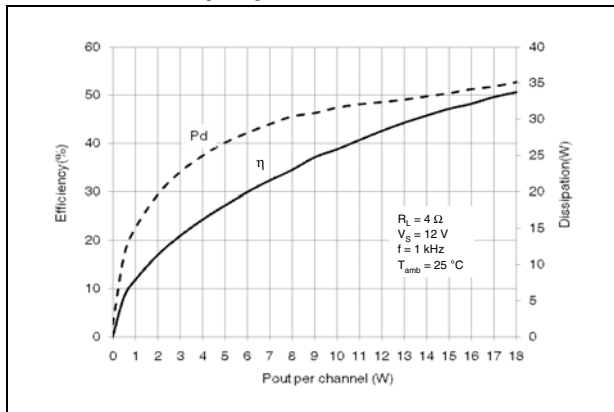

Figure 6. Total harmonic distortion vs output power

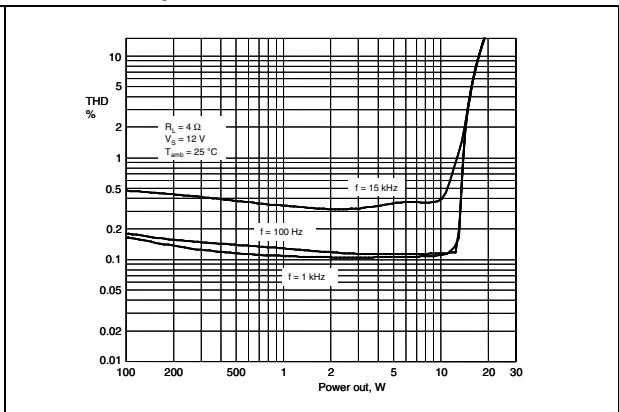
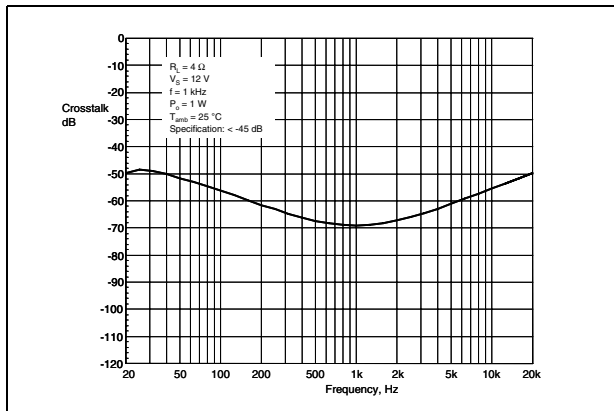

Figure 7. Crosstalk vs frequency



3.2 For 8-Ω loads

Figure 8. Output power vs supply voltage

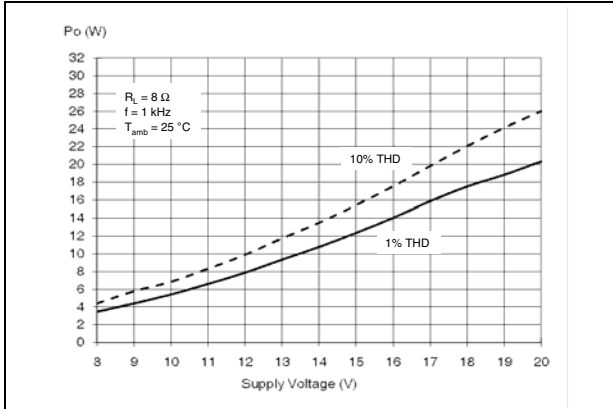

Figure 9. Quiescent current vs supply voltage

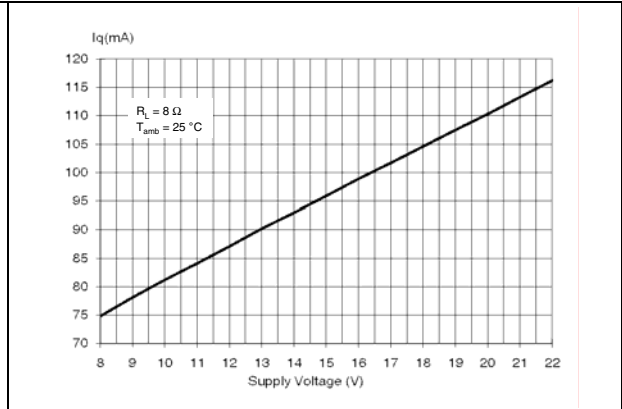

Figure 10. Efficiency, device dissipation vs output power

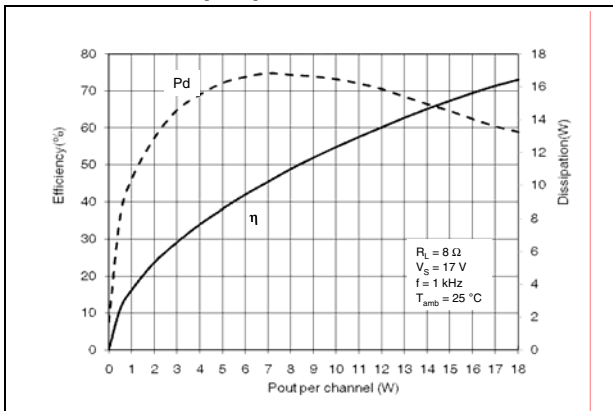

Figure 11. Total harmonic distortion vs output power

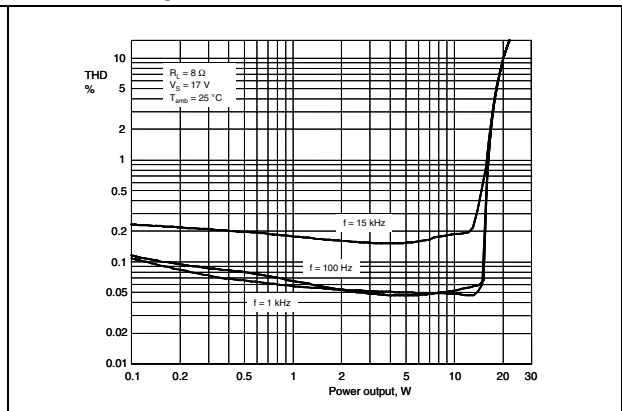

Figure 12. Crosstalk vs frequency

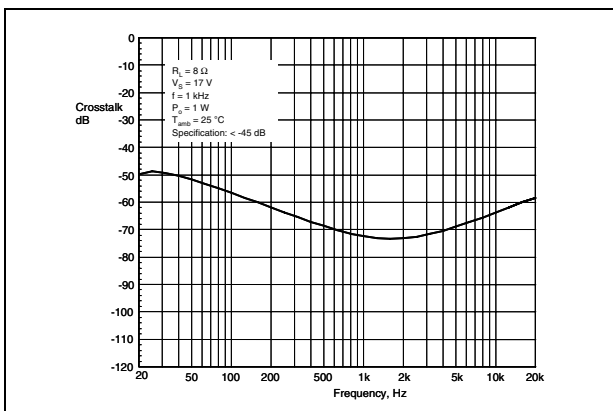
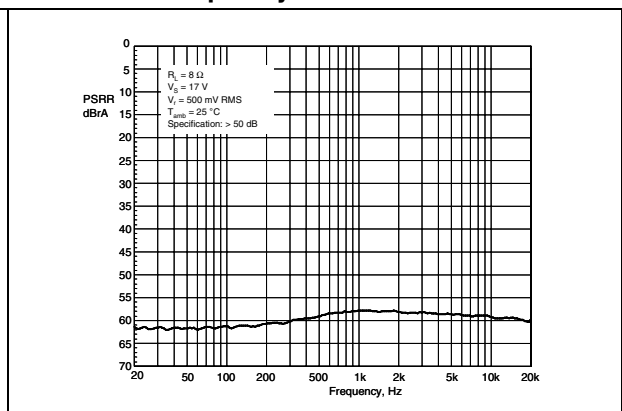
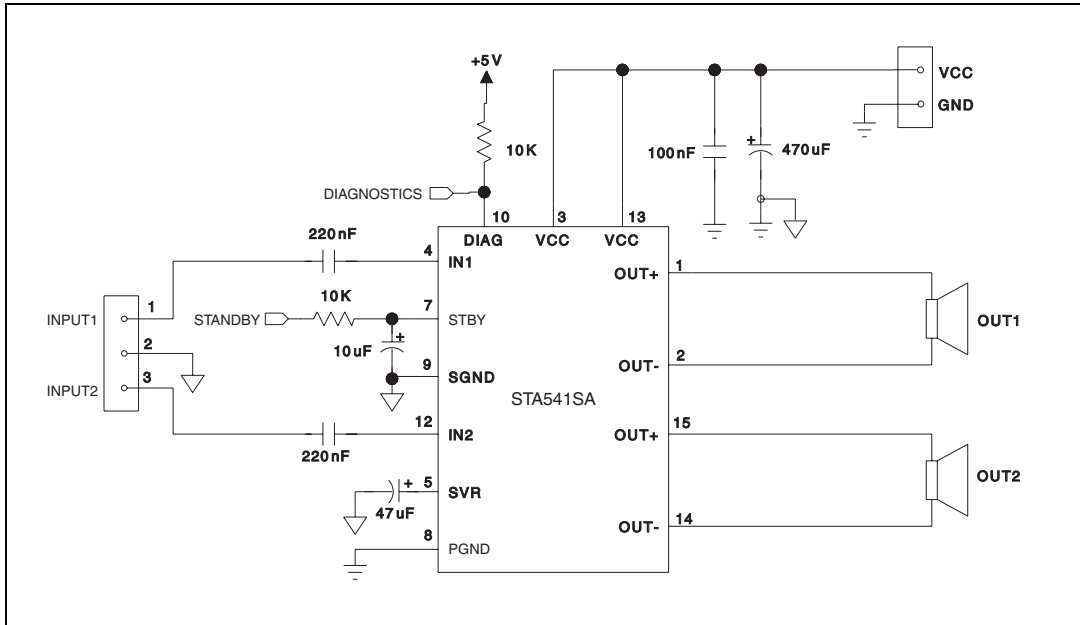

Figure 13. Power supply rejection ratio vs frequency



4 Applications

Figure 14. Applications circuit



5 Demonstration board

Figure 15. Demonstration board schematic

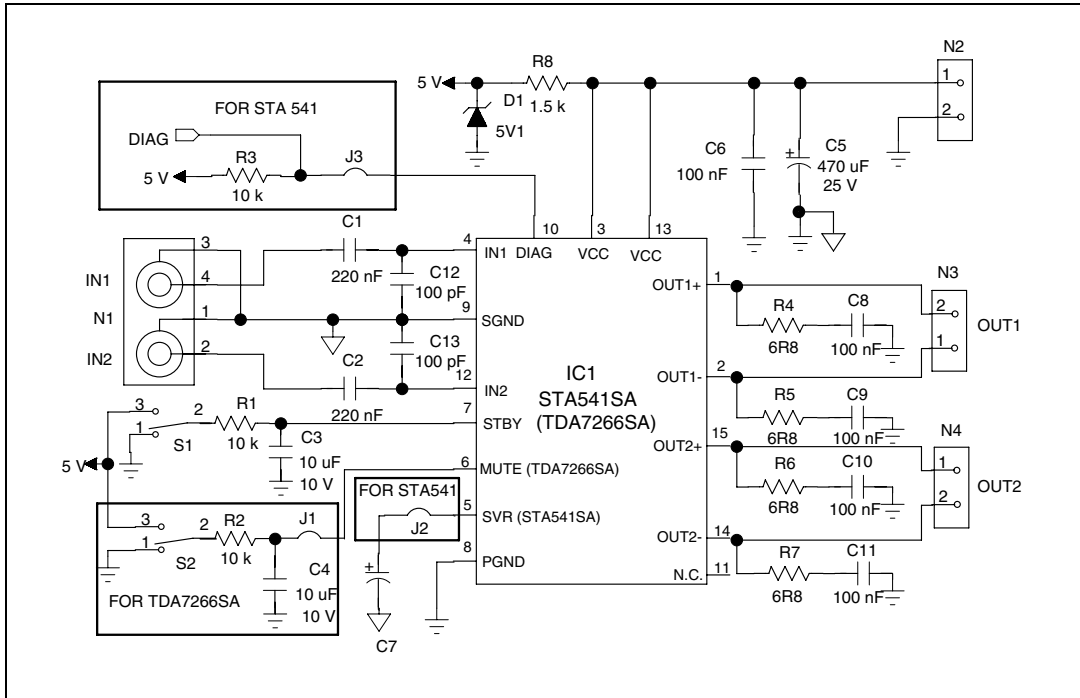
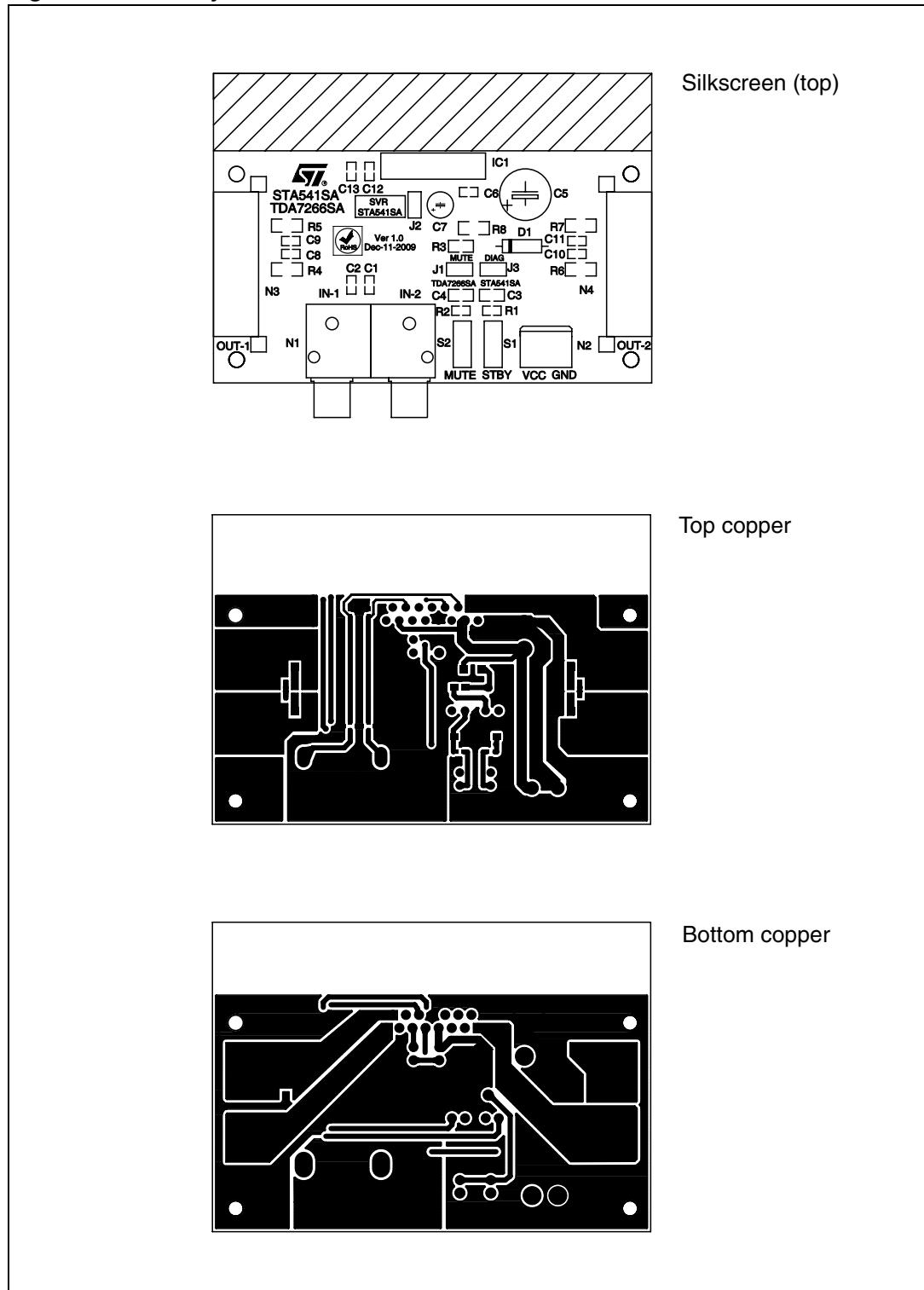

Figure 16. PCB layout



6 Thermal information

In order to avoid the premature onset of the thermal protection, see [Figure 6: Electrical characteristics on page 9](#), it is necessary to calculate the required thermal resistance, R_{th_HS} , for the heatsink.

The parameters that influence the calculation are:

- maximum power dissipated in the device (P_{dMAX})
- maximum thermal resistance junction to case (R_{th_j-case})
- maximum ambient temperature T_{ambMAX}

There is also an additional term that depends on the quiescent current, I_q .

6.1 Heatsink specification examples

6.1.1 R_{th_HS} calculation

Given that $V_S = 17\text{ V}$, $R_L = 2 \times 8\ \Omega$, $P_{outMAX} = 2 \times 20\text{ W}$

then the maximum power dissipated in the device is:

$$P_{dMAX} = 2 * (2 * V_S / (\pi^2 * R_L)) = 2 * 7.32 = 14.6\text{ W}$$

Using this value the required thermal resistance of the heatsink can be determined:

$$R_{th_HS} = (150 - T_{ambMAX}) / P_{dMAX} - R_{th_j-case} = (150 - 70) / 14.6 - 2.5 = 3.0\text{ }^\circ\text{C/W}$$

6.1.2 Calculations using music power

The thermal resistance value calculated in the above example specifies a heatsink capable of sustaining the maximum dissipated power. Realistically, however, and as explained in the Applications note (AN1965), the heatsink can be smaller when the application is musical content.

When music power is considered the resulting dissipation is about 40% less than the calculated maximum. Thus, a smaller or cheaper heatsink can be employed.

Using the values in the previous example, the maximum dissipated power reduces to:

$$P_{dMAX} = 14.6 - 40\% = 8.8\text{ W}$$

leading to a heatsink thermal resistance of $R_{th_HS} = 6.6\text{ }^\circ\text{C/W}$.

7 Practical information

7.1 Internally fixed gain

The advantages in internally fixing the gain to 26 dB are:

- components and space saving
- output noise, supply voltage rejection and distortion optimization.

7.2 Silent turn on/off and muting/standby function

The standby mode can be easily activated by means of a CMOS logic level applied to pin STBY through a RC filter.

In standby, the device is turned off, drawing typically 1 mA from the supply and the output attenuation is 80 dB minimum.

All switch-on and switch-off operations are virtually pop-free. Furthermore, at turn-on the device stays muted for a time determined by the value of the capacitor on pin SVR. This prevents transients coming from previous stages which otherwise could produce unpleasant acoustic effects at the speakers.

7.3 Driving circuit for standby mode

Some precautions need to be taken when designing the driving circuit for pin 7, STBY. For instance, the pin cannot be directly driven by a voltage source having a current capability higher than 5 mA. In practical cases a series resistor must be inserted, giving it the double purpose of limiting the current at pin 7 and to smooth down the standby on/off transitions. When done in combination with a capacitor it prevents output pop.

A capacitor of at least 100 nF from pin 7 to SGND is necessary to ensure correct turn-on (see also [Figure 14: Applications circuit on page 13](#)).

7.4 Built-in protection

7.4.1 Diagnostic facilities (pin 10)

The STA541SA is equipped with diagnostic circuitry that is able to detect the following events:

- clipping of the output signal
- thermal shutdown
- output fault:
 - short circuit to ground
 - short circuit to supply
 - soft short circuit at turn-on

The event is signalled when the open collector output of pin 10 (DIAG) begins to sink current.

7.4.2 Short-circuit protection

Reliable and safe operation in the presence of all kinds of output short circuit is assured by the built-in protection. As well as the AC/DC short circuit to GND and to V_S , and across the speaker, there is a soft short-circuit condition which is signalled on pin DIAG during the turn-on phase to verify output circuit integrity in order to ensure correct amplifier operation.

As mentioned previously, it is important to limit the external current driving pin STBY to 5 mA, the reason being that the associated circuitry is normally disabled with currents greater than 5 mA.

7.4.3 Clipping detection

Figure 17. Clipping detection waveforms

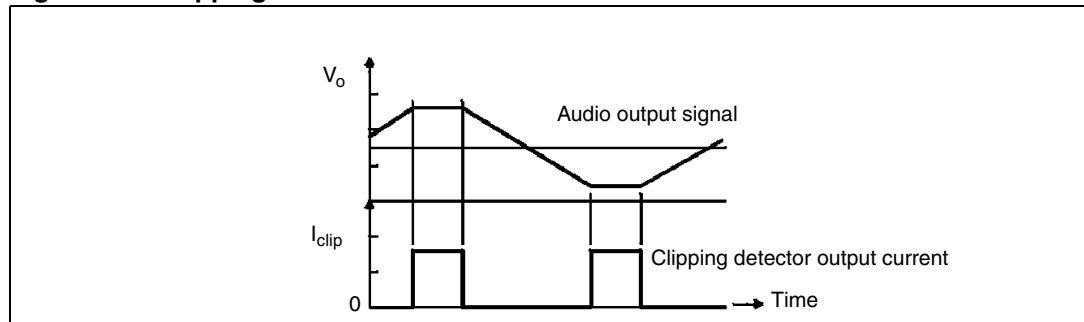

A gain-compression function is initiated whenever the amplifier is overdriven. When a certain distortion level is reached at each output, pin 10 starts to sink current.

7.4.4 Thermal shutdown

With the thermal shutdown feature the diagnostics output on pin 10 signals the closeness of the junction temperature to the shutdown threshold. Typically, current sinking at pin 10 starts approximately 10 °C before the shutdown temperature is reached.

Figure 18. Configuration of pin DIAG

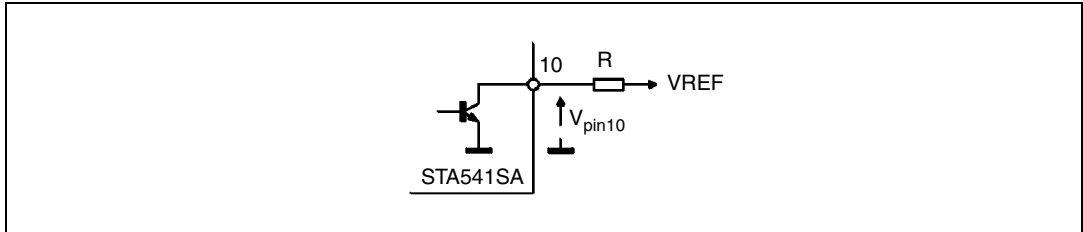
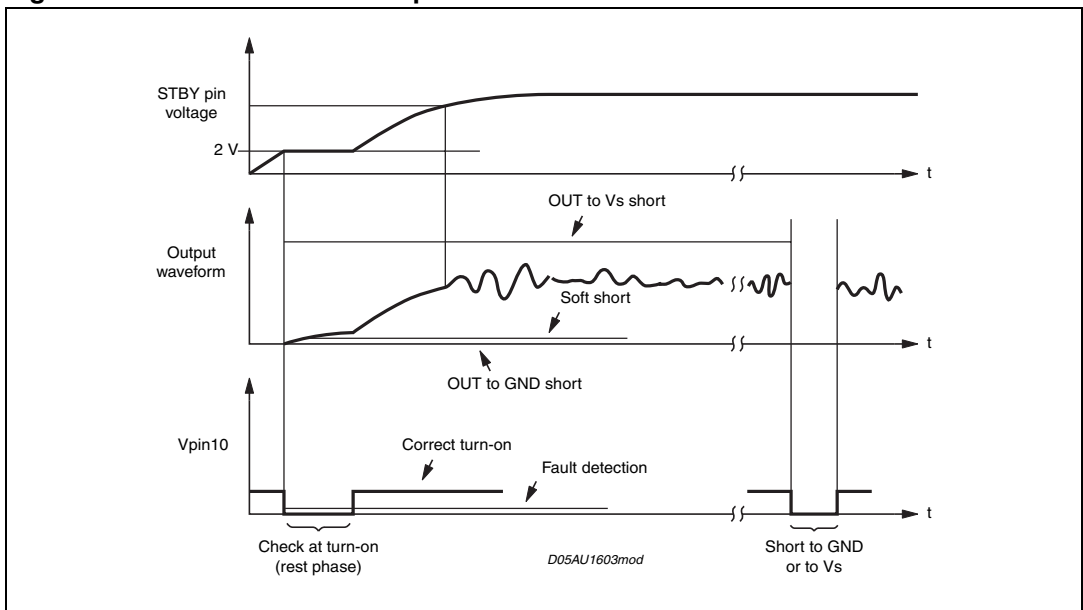

Figure 19. Fault waveforms on pin DIAG



7.5 Handling the diagnostic information

As different diagnostic information (clipping detection, output fault, approaching thermal shutdown) becomes available at pin 10 so the behavior of the signal at this pin changes.

In order to discriminate the event the signal on pin 10 must be interpreted correctly.

Figure 20 shows a combination of events on the output waveform and the corresponding output on pin 10.

These events could be diagnosed based on the timing of the output signal on pin 10. For example, the clip-detector signalling under fault conditions could produce a low level for a short time. On the other hand, an output short circuit would probably produce a low level for a much longer time. With these assumptions, an interface circuit based on the one shown in Figure 21 could differentiate the information and flag the appropriate circuits.

Figure 20. Waveforms

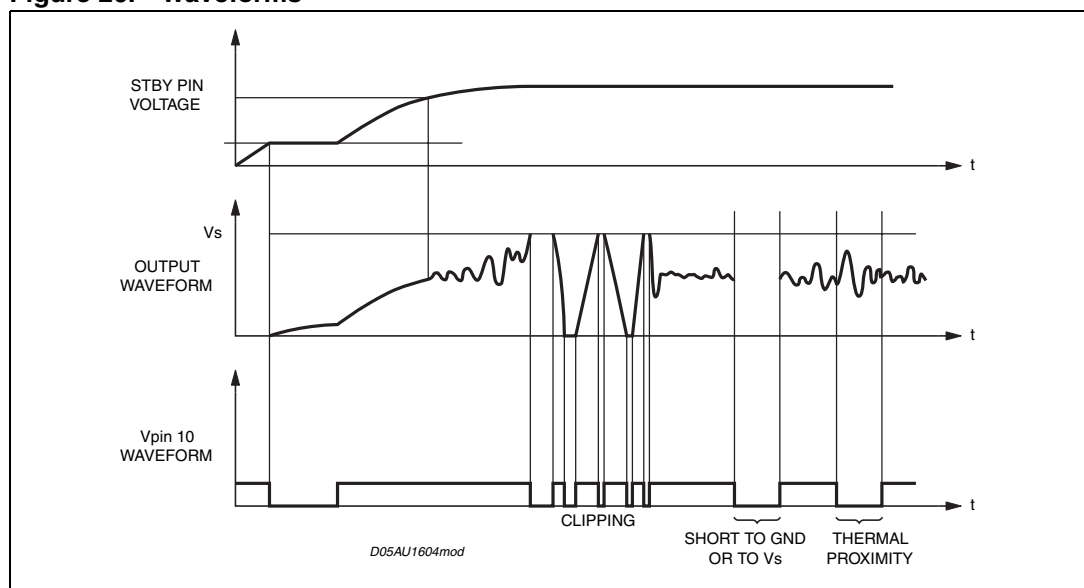
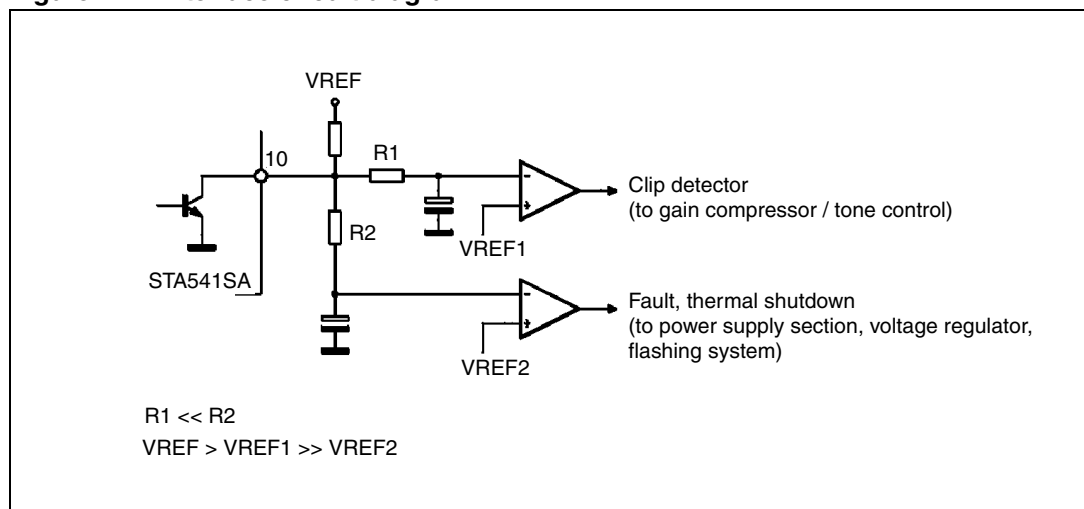

Figure 21. Interface circuit diagram



7.6 PCB ground layout

The device has two distinct ground pins, PGND (power ground) and SGND (signal ground) which are disconnected from each other at chip level. For superior performance the pins PGND and SGND must be connected together on the PCB by low-resistance tracks.

For the PCB ground configuration, a star-like arrangement, where the center is represented by the supply-filtering electrolytic capacitor ground, is recommended. In an arrangement such as this at least two separate paths must be provided, one for PGND and one for SGND.

The correct ground assignments are as follows:

- on SGND:
 - standby capacitor (pin 7, or any other standby driving networks)
 - SVR capacitor (pin 5), to be placed as close as possible to the device
 - input signal ground (from active/passive signal processor stages)
- on PGND:
 - power supply filtering capacitors for pins 3 and 13; the negative terminal of the electrolytic capacitor(s) must be directly tied to the battery negative line and this should represent the starting point for all the ground paths.

7.7 Mute function

If the mute function is desired, it can be implemented on pin 5, SVR, as shown in [Figure 22](#).

Figure 22. Optional mute function circuit

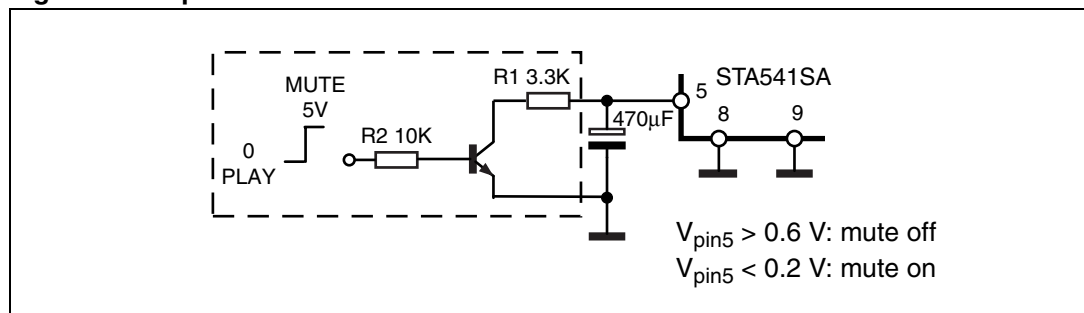

Using a different value for R1 than the suggested 3.3 k Ω , results in two different situations:

- R1 > 3.3 k Ω :
 - pop noise improvement
 - lower mute attenuation
- R1 < 3.3 k Ω :
 - pop noise degradation
 - higher mute attenuation

In order to meet environmental requirements, ST offers these devices in different grades of ECOPACK[®] packages, depending on their level of environmental compliance. ECOPACK[®] specifications, grade definitions and product status are available at: www.st.com. ECOPACK[®] is an ST trademark.

Table 7. Package dimensions

Reference	Dimensions in mm			Dimensions in inches			Notes
	Min	Typ	Max	Min	Typ	Max	
A	-	-	3.2	-	-	0.126	-
B	-	-	1.05	-	-	0.041	-
C	-	0.15	-	-	0.006	-	-
D	-	1.5	-	-	0.059	-	-
E	0.49	-	0.55	0.019	-	0.021	-
F	0.65	-	0.73	0.026	-	0.029	-
F1	-	-	0.1	-	-	0.004	(1)
G	1.14	1.27	1.40	0.045	0.050	0.055	-
G1	17.57	17.78	17.91	0.692	0.700	0.705	-
H1	-	12	-	-	0.472	-	-
H2	-	18.6	-	-	0.732	-	-
H3	19.85	-	-	0.781	-	-	(2)
L	-	17.9	-	-	0.705	-	-
L1	-	14.55	-	-	0.573	-	-
L2	10.70	11.00	11.20	0.421	0.433	0.441	(2)
L3	-	5.5	-	-	0.217	-	-
M	-	2.54	-	-	0.1	-	-
M1	-	2.54	-	-	0.1	-	-
R	-	1.50	-	-	0.059	-	-
R1	-	3.30	-	-	0.130	-	-
R2	-	0.30	-	-	0.012	-	-
R3	-	0.50	-	-	0.019	-	-
S	-	0.70	-	-	0.028	-	-
V	-	10 deg	-	-	10 deg	-	-

Table 7. Package dimensions (continued)

Reference	Dimensions in mm			Dimensions in inches			Notes
	Min	Typ	Max	Min	Typ	Max	
V1	-	5 deg	-	-	5 deg	-	-
V2	-	75 deg	-	-	75 deg	-	-

1. No intrusion allowed inwards the leads
2. H3 and L2 do not include mold flash or protrusions. Mold flash or protrusions shall not exceed 0.15 mm per side

9 Revision history

Table 8. Document revision history

Date	Revision	Changes
27-Jan-2010	1	Initial release.
02-Apr-2012	2	Updated document status from preliminary to full production data Modified V_{STBY} to V_{SB} and updated parameters in Table 6

Please Read Carefully:

Information in this document is provided solely in connection with ST products. STMicroelectronics NV and its subsidiaries ("ST") reserve the right to make changes, corrections, modifications or improvements, to this document, and the products and services described herein at any time, without notice.

All ST products are sold pursuant to ST's terms and conditions of sale.

Purchasers are solely responsible for the choice, selection and use of the ST products and services described herein, and ST assumes no liability whatsoever relating to the choice, selection or use of the ST products and services described herein.

No license, express or implied, by estoppel or otherwise, to any intellectual property rights is granted under this document. If any part of this document refers to any third party products or services it shall not be deemed a license grant by ST for the use of such third party products or services, or any intellectual property contained therein or considered as a warranty covering the use in any manner whatsoever of such third party products or services or any intellectual property contained therein.

UNLESS OTHERWISE SET FORTH IN ST'S TERMS AND CONDITIONS OF SALE ST DISCLAIMS ANY EXPRESS OR IMPLIED WARRANTY WITH RESPECT TO THE USE AND/OR SALE OF ST PRODUCTS INCLUDING WITHOUT LIMITATION IMPLIED WARRANTIES OF MERCHANTABILITY, FITNESS FOR A PARTICULAR PURPOSE (AND THEIR EQUIVALENTS UNDER THE LAWS OF ANY JURISDICTION), OR INFRINGEMENT OF ANY PATENT, COPYRIGHT OR OTHER INTELLECTUAL PROPERTY RIGHT.

UNLESS EXPRESSLY APPROVED IN WRITING BY TWO AUTHORIZED ST REPRESENTATIVES, ST PRODUCTS ARE NOT RECOMMENDED, AUTHORIZED OR WARRANTED FOR USE IN MILITARY, AIR CRAFT, SPACE, LIFE SAVING, OR LIFE SUSTAINING APPLICATIONS, NOR IN PRODUCTS OR SYSTEMS WHERE FAILURE OR MALFUNCTION MAY RESULT IN PERSONAL INJURY, DEATH, OR SEVERE PROPERTY OR ENVIRONMENTAL DAMAGE. ST PRODUCTS WHICH ARE NOT SPECIFIED AS "AUTOMOTIVE GRADE" MAY ONLY BE USED IN AUTOMOTIVE APPLICATIONS AT USER'S OWN RISK.

Resale of ST products with provisions different from the statements and/or technical features set forth in this document shall immediately void any warranty granted by ST for the ST product or service described herein and shall not create or extend in any manner whatsoever, any liability of ST.

ST and the ST logo are trademarks or registered trademarks of ST in various countries.

Information in this document supersedes and replaces all information previously supplied.

The ST logo is a registered trademark of STMicroelectronics. All other names are the property of their respective owners.

© 2012 STMicroelectronics - All rights reserved

STMicroelectronics group of companies

Australia - Belgium - Brazil - Canada - China - Czech Republic - Finland - France - Germany - Hong Kong - India - Israel - Italy - Japan - Malaysia - Malta - Morocco - Philippines - Singapore - Spain - Sweden - Switzerland - United Kingdom - United States of America

www.st.com