

50 W mono BTL class-D audio amplifier

Features

- 50 W continuous output power:
 $R_L = 6 \Omega$, THD = 10% at $V_{CC} = 25 \text{ V}$
- 40 W continuous output power:
 $R_L = 8 \Omega$, THD = 10% at $V_{CC} = 25 \text{ V}$
- Wide range single supply operation (10 - 26 V)
- High efficiency ($\eta = 90\%$)
- Four selectable, fixed gain settings of nominally 21.6 dB, 27.6 dB, 31.1 dB and 33.6 dB
- Differential inputs minimize common-mode noise
- Standby and mute features
- Short-circuit protection
- Thermal-overload protection
- Externally synchronizable

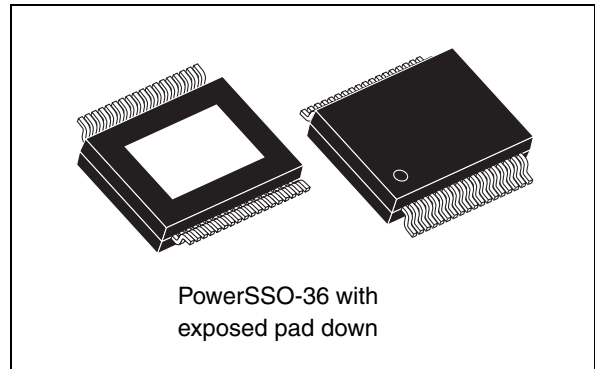

Description

The TDA7492MV is a mono BTL class-D audio amplifier with single power supply designed for home systems and docking stations.

Thanks to the high efficiency and an exposed-pad-down (EPD) package no heatsink is required.

Table 1. Device summary

Order code	Operating temp. range	Package	Packaging
TDA7492MV	0 to 70 °C	PowerSSO-36 EPD	Tube
TDA7492MV13TR	0 to 70 °C	PowerSSO-36 EPD	Tape and reel

Contents

- 1 Device block diagram 5**
- 2 Pin description 6**
 - 2.1 Pin out 6
 - 2.2 Pin list 7
- 3 Electrical specifications 8**
 - 3.1 Absolute maximum ratings 8
 - 3.2 Thermal data 8
 - 3.3 Electrical specifications 8
- 4 Characterization curves 10**
 - 4.1 For 6-Ω load 10
 - 4.2 For 8-Ω load 13
 - 4.3 Test board 16
- 5 Package mechanical data 17**
- 6 Applications information 19**
 - 6.1 Applications circuit 19
 - 6.2 Mode selection 20
 - 6.3 Gain setting 21
 - 6.4 Input resistance and capacitance 21
 - 6.5 Internal and external clocks 22
 - 6.5.1 Master mode (internal clock) 22
 - 6.5.2 Slave mode (external clock) 22
 - 6.6 Output low-pass filter 23
 - 6.7 Protection function 23
 - 6.8 Diagnostic output 24
- 7 Revision history 25**

List of tables

Table 1.	Device summary	1
Table 2.	Pin description list	7
Table 3.	Absolute maximum ratings	8
Table 4.	Thermal data	8
Table 5.	Electrical specifications	8
Table 6.	PowerSSO-36 EPD dimensions	18
Table 7.	Mode settings	20
Table 8.	Gain settings	21
Table 9.	How to set up SYNCLK	22
Table 10.	Document revision history	25

List of figures

Figure 1.	Internal block diagram	5
Figure 2.	Pin connection (top view, PCB view)	6
Figure 3.	Output power vs supply voltage	10
Figure 4.	THD vs output power (1 kHz)	10
Figure 5.	THD vs output power (100 Hz)	11
Figure 6.	THD vs frequency (100 mW)	11
Figure 7.	THD vs frequency	11
Figure 8.	Frequency response	12
Figure 9.	FFT (0 dB)	12
Figure 10.	FFT (-60 dB)	12
Figure 11.	Output power vs supply voltage	13
Figure 12.	THD vs output power (1 kHz)	13
Figure 13.	THD vs output power (100 Hz)	14
Figure 14.	THD vs frequency (100 mW)	14
Figure 15.	THD vs frequency	14
Figure 16.	Frequency response	15
Figure 17.	FFT (0 dB)	15
Figure 18.	FFT (-60 dB)	15
Figure 19.	Test board layout	16
Figure 20.	PowerSSO-36 EPD outline drawing	17
Figure 21.	Applications circuit for class-D amplifier	19
Figure 22.	Standby and mute circuits	20
Figure 23.	Turn-on/off sequence for minimizing speaker “pop”	20
Figure 24.	Device input circuit and frequency response	21
Figure 25.	Master and slave connection	22
Figure 26.	Typical LC filter for a 8-Ω speaker	23
Figure 27.	Typical LC filter for a 4-Ω speaker	23
Figure 28.	Behavior of pin DIAG for various protection conditions	24

1 Device block diagram

Figure 1 shows the block diagram of the TDA7492MV.

Figure 1. Internal block diagram

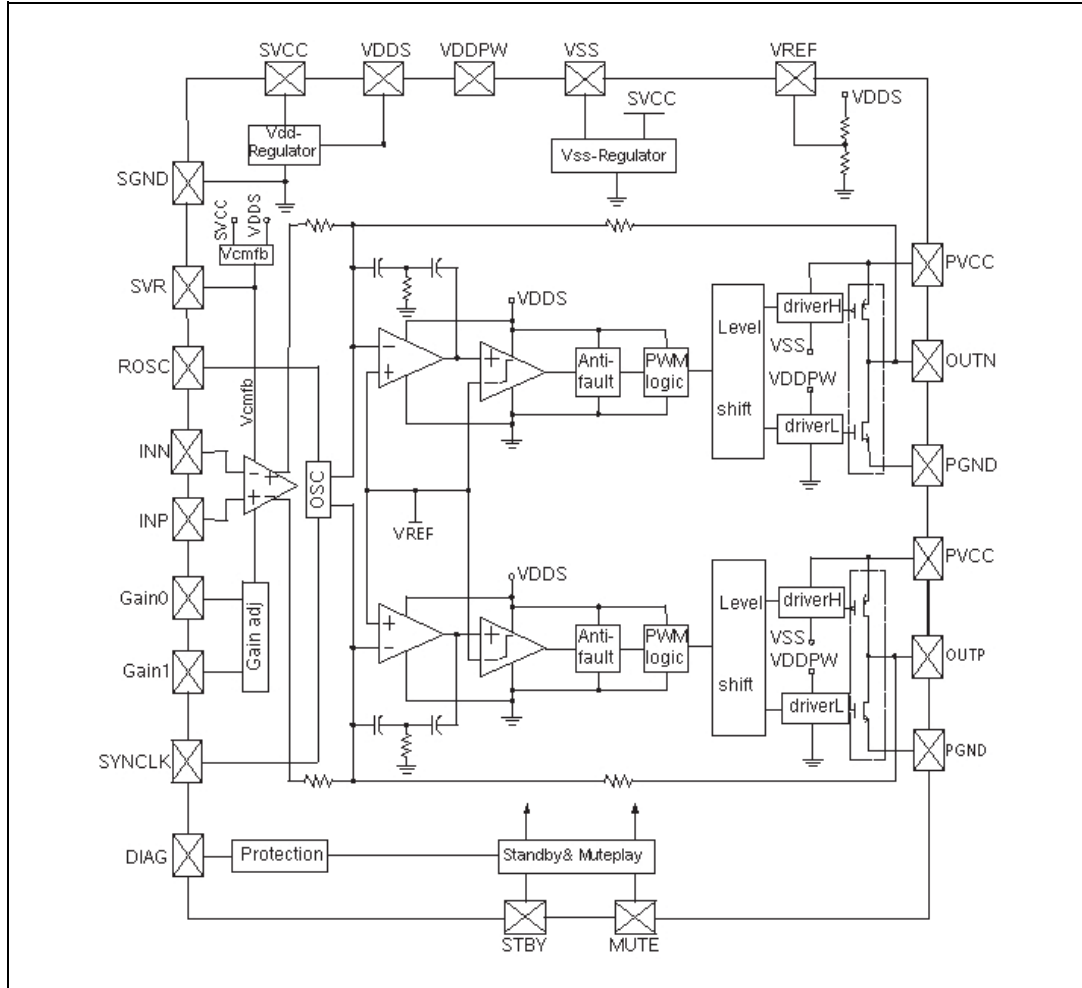

2 Pin description

2.1 Pin out

Figure 2. Pin connection (top view, PCB view)

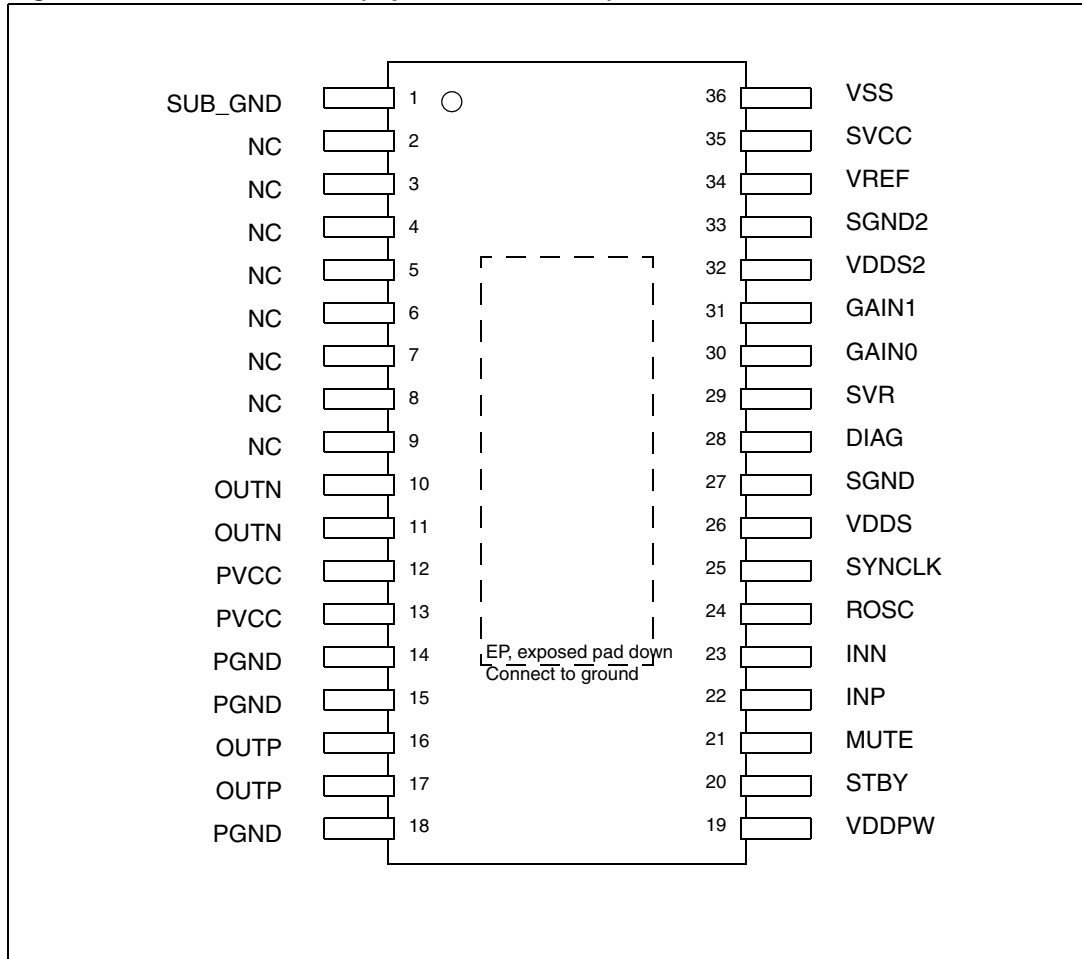

2.2 Pin list

Table 2. Pin description list

Number	Name	Type	Description
1	SUB_GND	POWER	Connect to the frame
2,3	NC	-	No internal connection
4,5	NC	-	No internal connection
6,7	NC	-	No internal connection
8,9	NC	-	No internal connection
10,11	OUTN	OUT	Negative PWM output
12,13	PVCC	POWER	Power supply for output channel
14,15	PGND	POWER	Power ground for output channel
16,17	OUTP	OUT	Positive PWM output
18	PGND	POWER	Power supply ground
19	VDDPW	OUT	3.3-V (nominal) regulator output referred to ground for power stage
20	STBY	INPUT	Standby mode control
21	MUTE	INPUT	Mute mode control
22	INP	INPUT	Positive differential input
23	INN	INPUT	Negative differential input
24	ROSC	OUT	Master oscillator frequency-setting pin
25	SYNCLCK	IN/OUT	Clock in/out for external oscillator
26	VDDS	OUT	3.3-V (nominal) regulator output referred to ground for signal blocks
27	SGND	POWER	Signal ground
28	DIAG	OUT	Open-drain diagnostic output
29	SVR	OUT	Supply voltage rejection
30	GAIN0	INPUT	Gain setting input 1
31	GAIN1	INPUT	Gain setting input 2
32	VDDS2	INPUT	To be connected to VDDS (pin 26)
33	SGND2	INPUT	To be connected to SGND (pin 27)
34	VREF	OUT	Half VDDS (nominal) referred to ground
35	SVCC	POWER	Signal power supply
36	VSS	OUT	3.3-V (nominal) regulator output referred to power supply
-	EP	-	Exposed pad for ground-plane heatsink, to be connected to ground

3 Electrical specifications

3.1 Absolute maximum ratings

Table 3. Absolute maximum ratings

Symbol	Parameter	Value	Unit
V_{CC}	DC supply voltage for pins PVCC, SVCC	30	V
V_I	Voltage limits for input pins STBY, MUTE, INN, INP, GAIN0, GAIN1	-0.3 - 3.6	V
T_{op}	Operating temperature	0 to 70	°C
T_j	Junction temperature	-40 to 150	°C
T_{stg}	Storage temperature	-40 to 150	°C

3.2 Thermal data

Table 4. Thermal data

Symbol	Parameter	Min	Typ	Max	Unit
$R_{th\ j-case}$	Thermal resistance, junction to case	-	2	3	°C/W

3.3 Electrical specifications

Unless otherwise stated, the results in [Table 5](#) below are given for the conditions:

$V_{CC} = 25\text{ V}$, R_L (load) = 8 Ω , $R_{OSC} = R3 = 39\text{ k}\Omega$, $C8 = 100\text{ nF}$, $f = 1\text{ kHz}$, $G_V = 21.6\text{ dB}$ and $T_{amb} = 25\text{ °C}$.

Table 5. Electrical specifications

Symbol	Parameter	Condition	Min	Typ	Max	Unit
V_{CC}	Supply voltage for pins PVCCA, PVCCB, SVCC	-	10	-	26	V
I_q	Total quiescent current	Without LC	-	26	35	mA
I_{qSTBY}	Quiescent current in standby	-	-	2.5	5.0	μA
V_{OS}	Output offset voltage	Play mode	-100	-	100	mV
		Mute mode	-60	-	60	
I_{OCP}	Overcurrent protection threshold	$R_L = 0\ \Omega$	4.8	6.0	-	A
T_j	Junction temperature at thermal shutdown	-	-	150	-	°C
R_i	Input resistance	Differential input	48	60	-	k Ω
V_{OVP}	Overvoltage protection threshold	-	28	29	-	V

Table 5. Electrical specifications (continued)

Symbol	Parameter	Condition	Min	Typ	Max	Unit
V_{UVP}	Undervoltage protection threshold	-	-	-	7	V
R_{dsON}	Power transistor on resistance	High side	-	0.2	-	Ω
		Low side	-	0.2	-	
P_o	Output power	THD = 10%	-	40	-	W
		THD = 1%	-	32	-	
P_o	Output power	$R_L = 6 \Omega$, THD = 10%, $V_{CC} = 25V$	-	50	-	W
		$R_L = 6 \Omega$, THD = 1% $V_{CC} = 25V$	-	40	-	
P_D	Dissipated power	$P_o = 40W$, THD = 10%	-	4.0	-	W
η	Efficiency	$P_o = 40 W$	80	90	-	%
THD	Total harmonic distortion	$P_o = 1 W$	-	0.1	0.4	%
G_V	Closed-loop gain	GAIN0 = L, GAIN1 = L	20.6	21.6	22.6	dB
		GAIN0 = L, GAIN1 = H	26.6	27.6	28.6	
		GAIN0 = H, GAIN1 = L	30.1	31.1	32.1	
		GAIN0 = H, GAIN1 = H	32.6	33.6	34.6	
ΔG_V	Gain matching	-	-1	-	1	dB
eN	Total input noise	A Curve, $G_V = 20$ dB	-	20	-	μV
		$f = 22$ Hz to 22 kHz	-	25	35	
SVRR	Supply voltage rejection ratio	$f_r = 100$ Hz, $V_r = 0.5$ V, $C_{SVR} = 10 \mu F$	40	50	-	dB
T_r, T_f	Rise and fall times	-	-	50	-	ns
f_{SW}	Switching frequency	Internal oscillator	290	310	330	kHz
f_{SWR}	Output switching frequency range	With internal oscillator ⁽¹⁾	250	-	400	kHz
		With external oscillator ⁽²⁾	250	-	400	
V_{inH}	Digital input high (H)	-	2.3	-	-	V
V_{inL}	Digital input low (L)		-	-	0.8	
A_{MUTE}	Mute attenuation	$V_{MUTE} = 1$ V	60	80	-	dB

1. $f_{SW} = 10^6 / ((16 * R_{OSC} + 182) * 4)$ kHz, $f_{SYNCLK} = 2 * f_{SW}$ with $R3 = 39$ k Ω (see [Figure 21.](#)).

2. $f_{SW} = f_{SYNCLK} / 2$ with the frequency of the external oscillator.

4 Characterization curves

The following characterization curves were made using the TDA7492MV exposed-pad-down test board with $V_{CC} = 25\text{ V}$, a signal frequency of 1 kHz and an output power of 1 W unless otherwise specified.

The LC filter for the 8-Ω load uses components of 33 μH and 220 nF and for the 6-Ω load 22 μH and 220 nF.

4.1 For 6-Ω load

Figure 3. Output power vs supply voltage

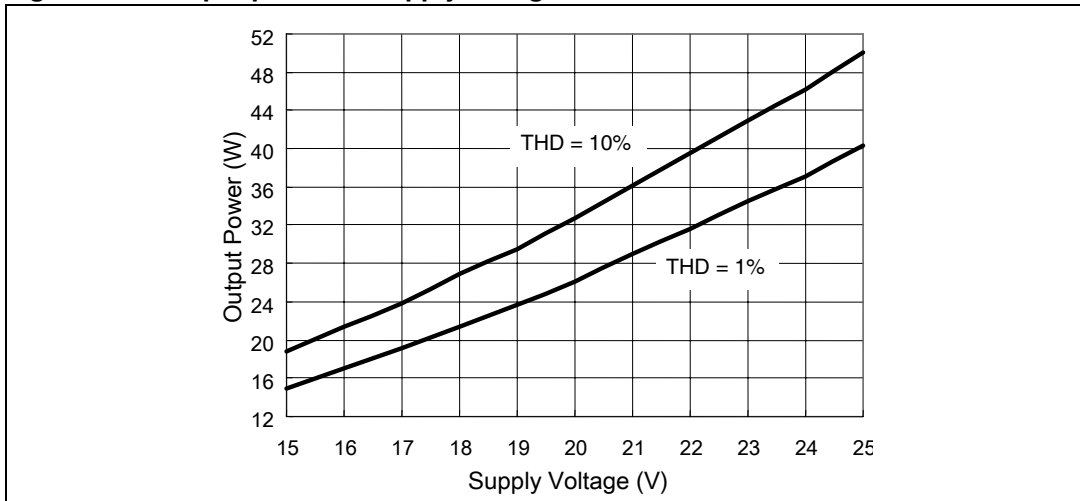

Figure 4. THD vs output power (1 kHz)

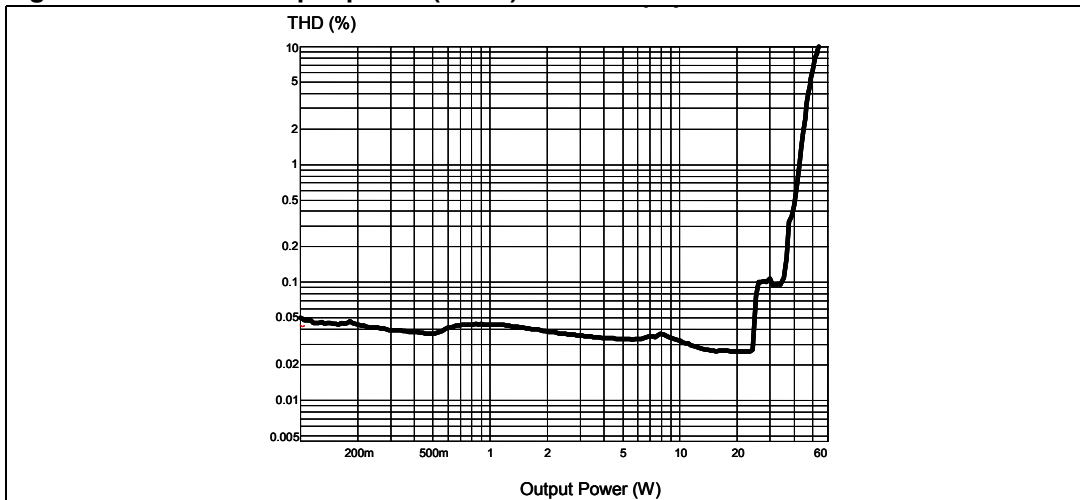

Figure 5. THD vs output power (100 Hz)

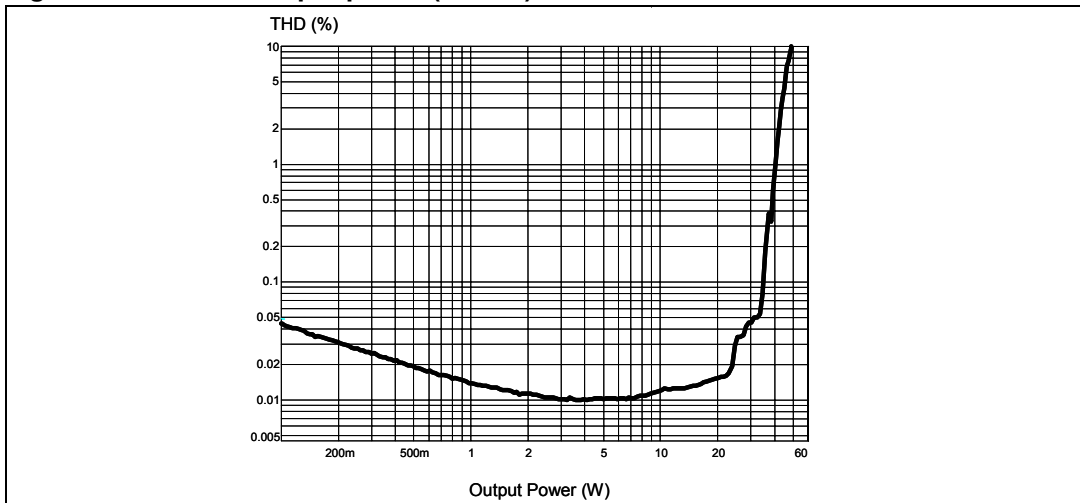

Figure 6. THD vs frequency (100 mW)

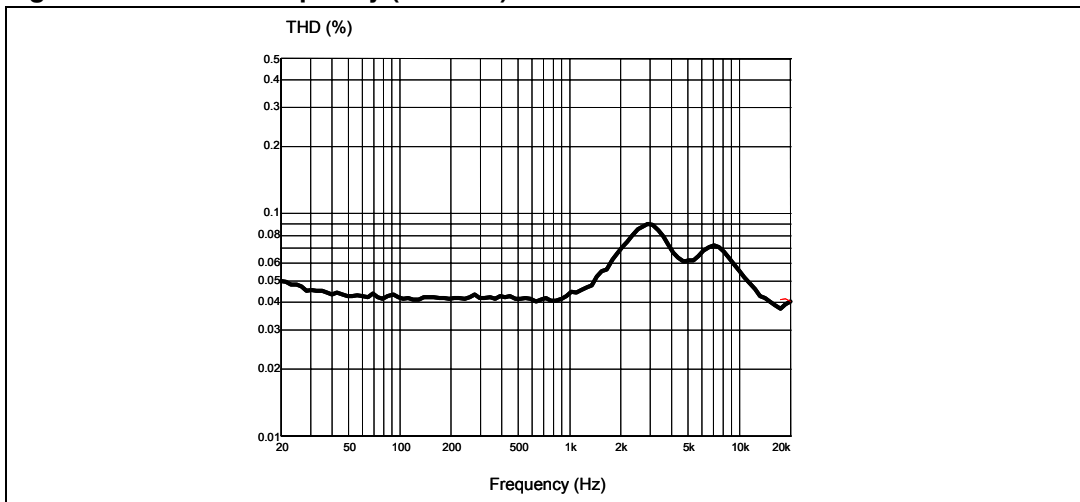

Figure 7. THD vs frequency

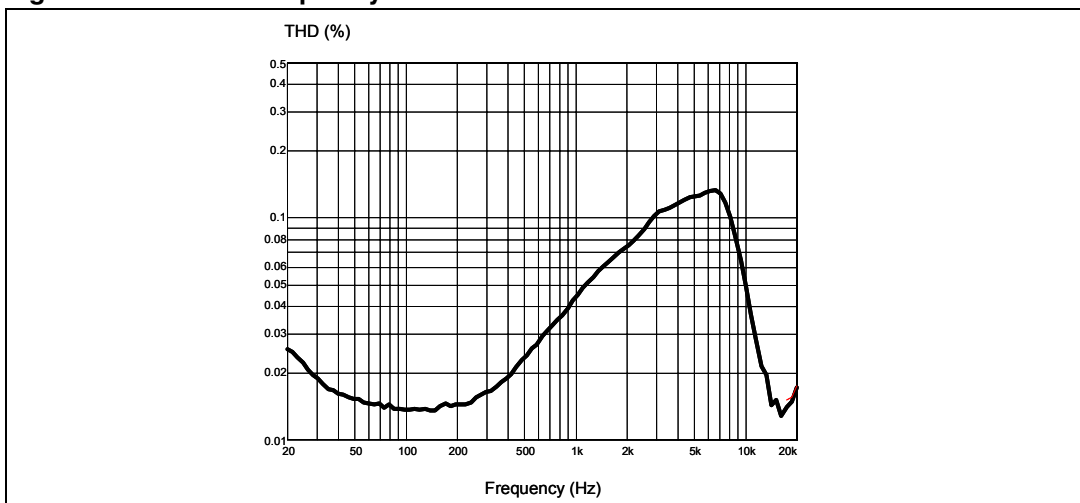

Figure 8. Frequency response

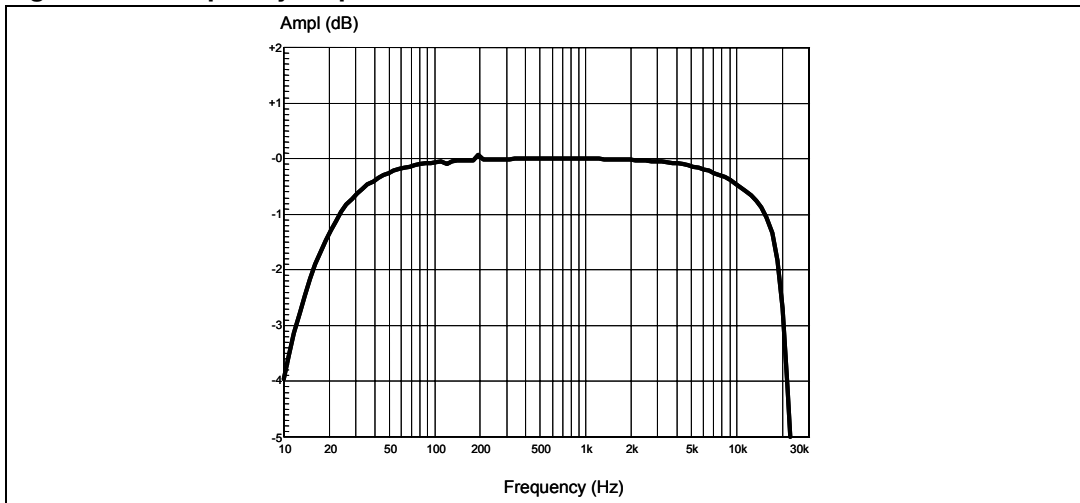

Figure 9. FFT (0 dB)

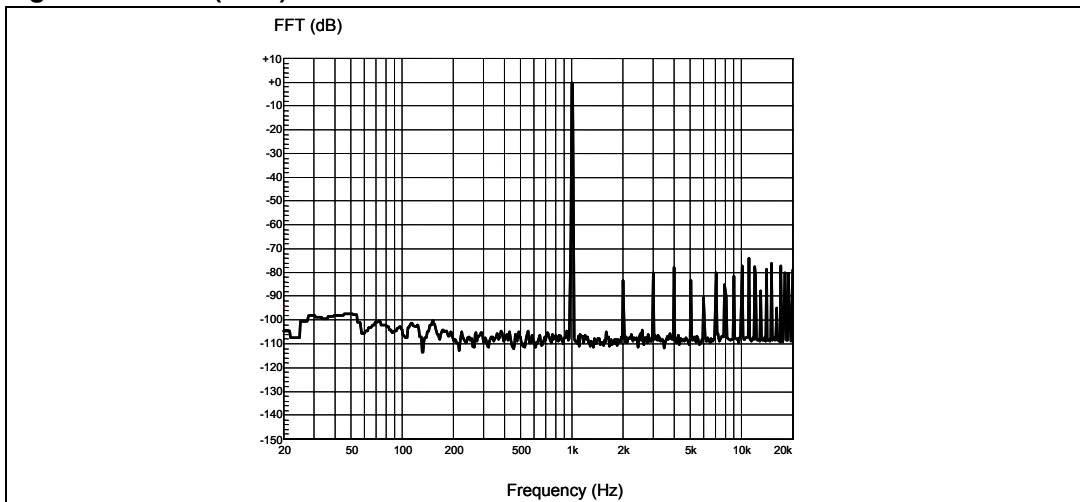
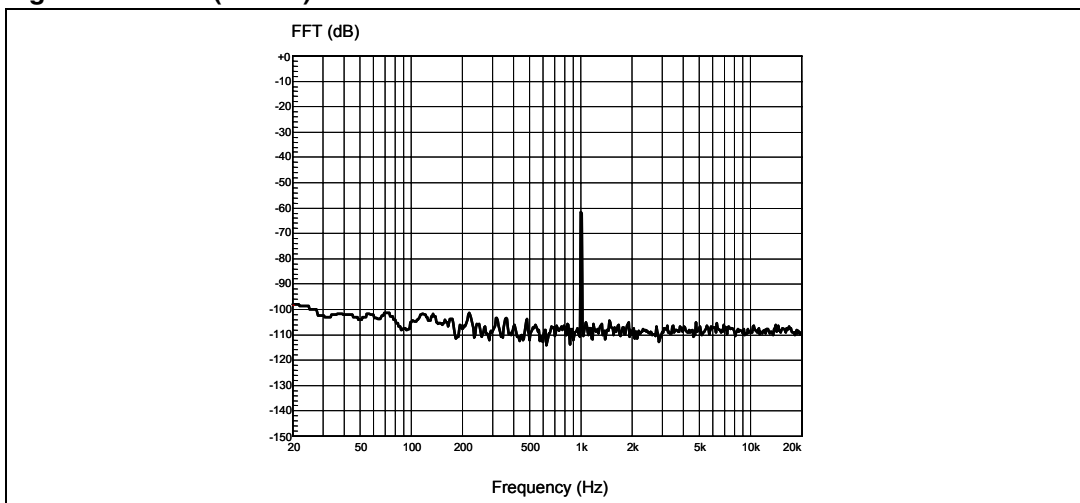

Figure 10. FFT (-60 dB)



4.2 For 8-Ω load

Figure 11. Output power vs supply voltage

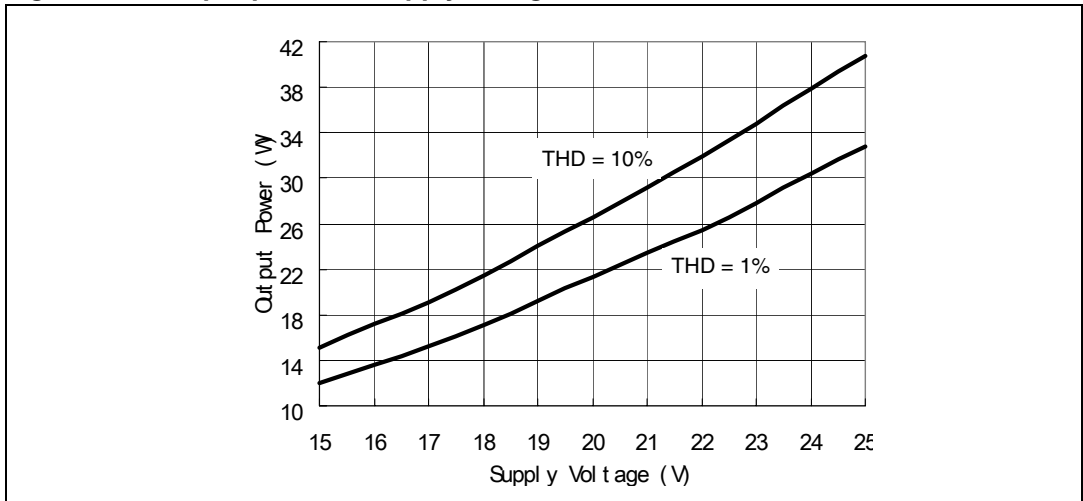

Figure 12. THD vs output power (1 kHz)

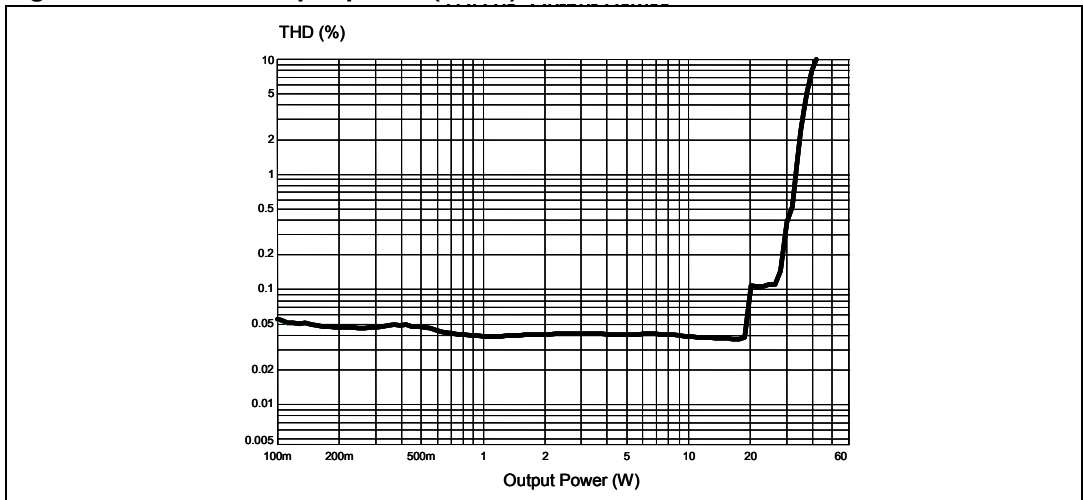

Figure 13. THD vs output power (100 Hz)

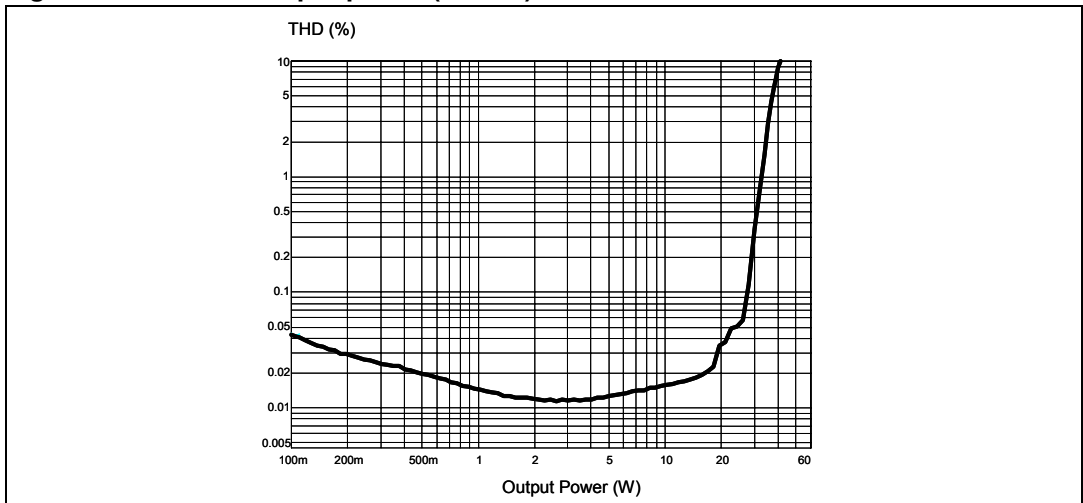

Figure 14. THD vs frequency (100 mW)

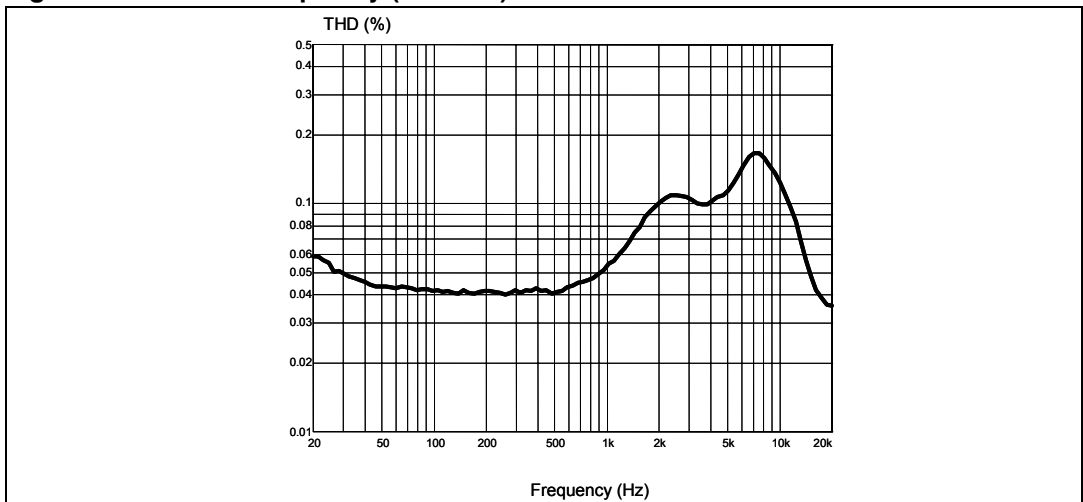

Figure 15. THD vs frequency

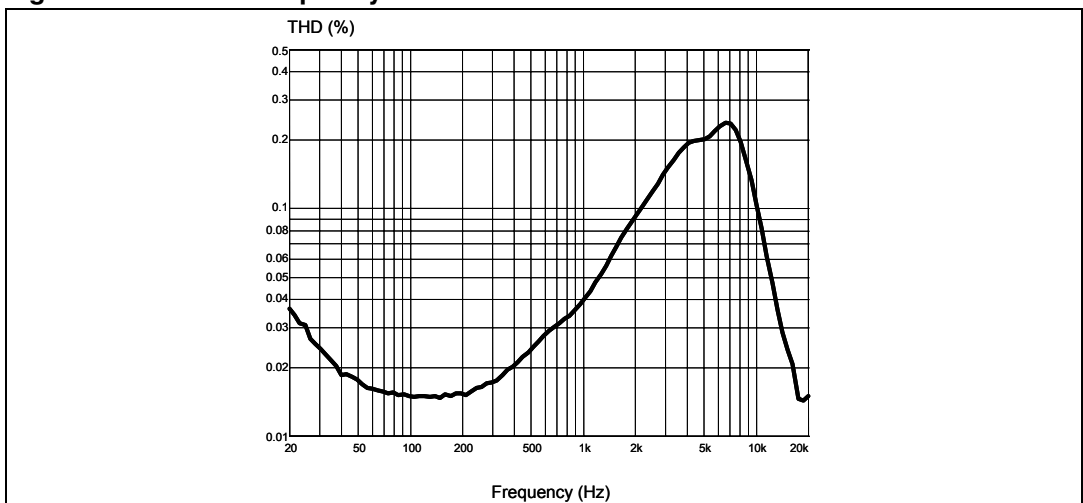

Figure 16. Frequency response

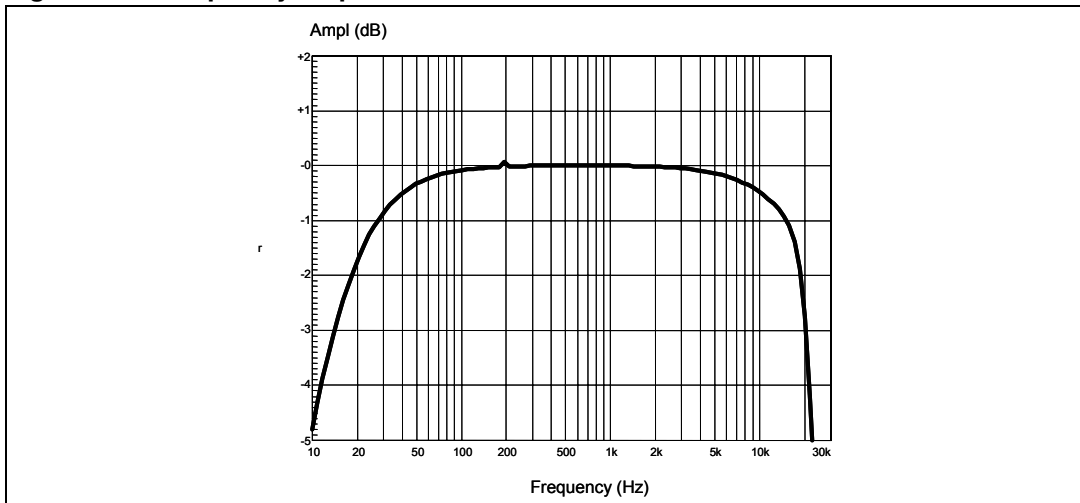

Figure 17. FFT (0 dB)

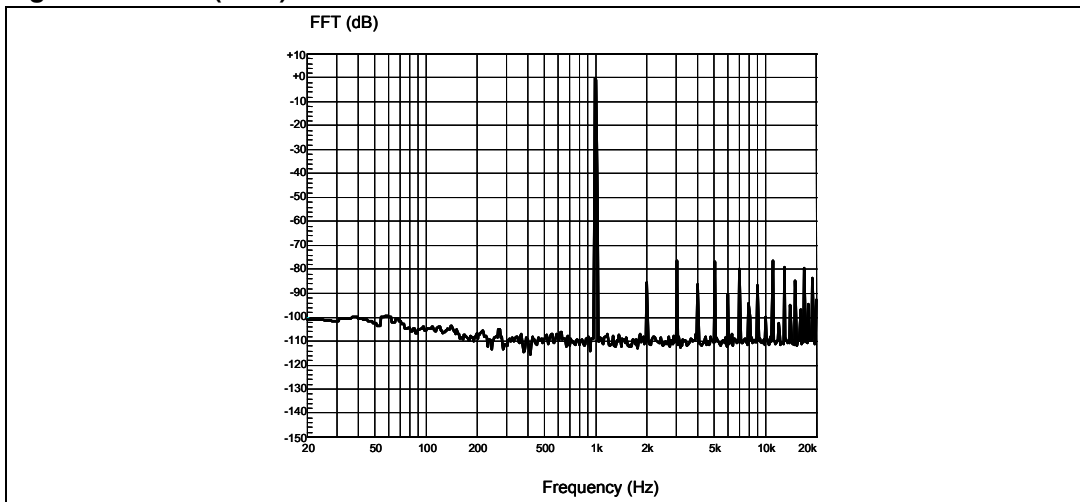
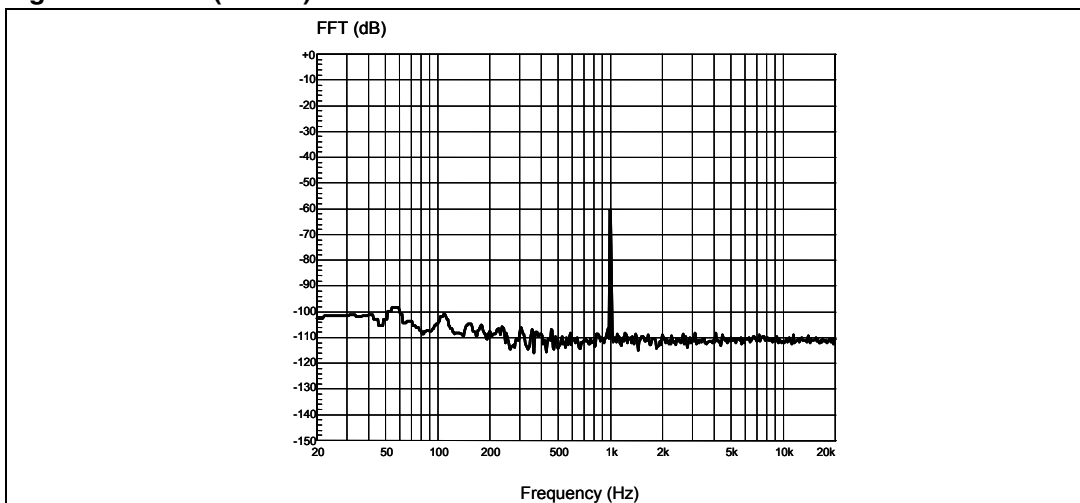
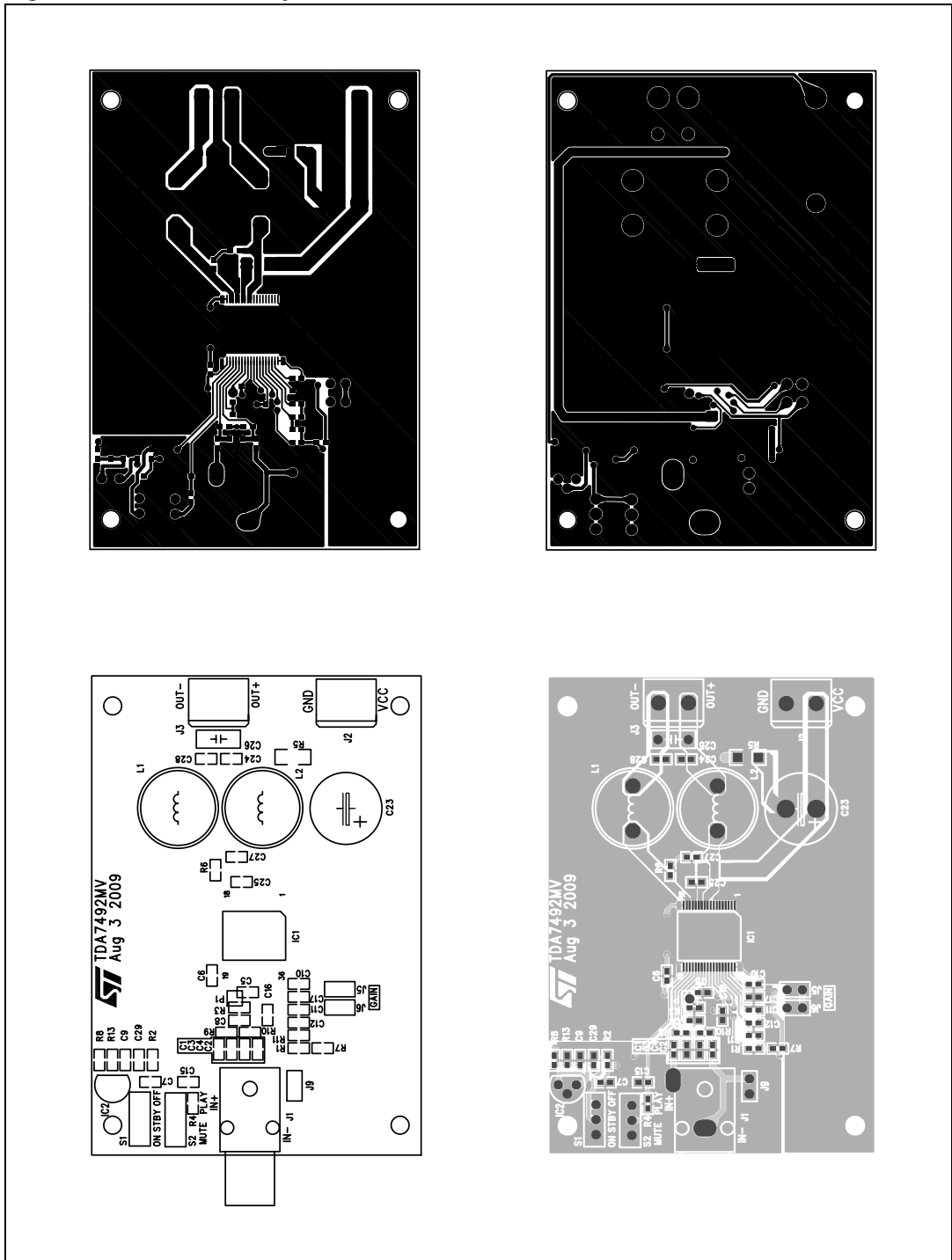

Figure 18. FFT (-60 dB)



4.3 Test board

Figure 19. Test board layout



5 Package mechanical data

The TDA7492MV comes in a 36-pin PowerSSO package with exposed pad down.

[Figure 20](#) below shows the package outline and [Table 6](#) gives the dimensions.

Figure 20. PowerSSO-36 EPD outline drawing

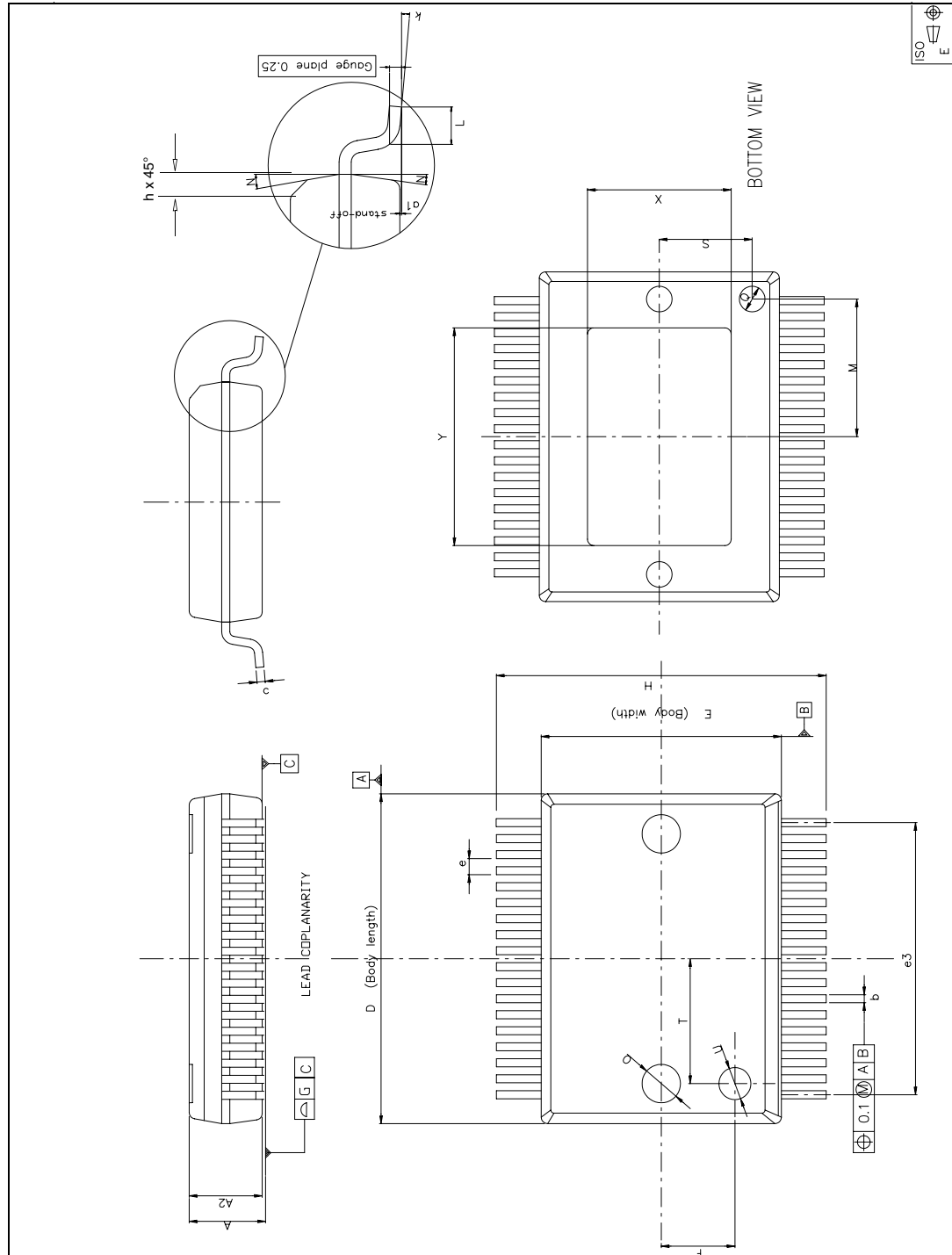

Table 6. PowerSSO-36 EPD dimensions

Symbol	Dimensions in mm			Dimensions in inches		
	Min	Typ	Max	Min	Typ	Max
A	2.15	-	2.47	0.085	-	0.097
A2	2.15	-	2.40	0.085	-	0.094
a1	0.00	-	0.10	0.000	-	0.004
b	0.18	-	0.36	0.007	-	0.014
c	0.23	-	0.32	0.009	-	0.013
D	10.10	-	10.50	0.398	-	0.413
E	7.40	-	7.60	0.291	-	0.299
e	-	0.5	-	-	0.020	-
e3	-	8.5	-	-	0.335	-
F	-	2.3	-	-	0.091	-
G	-	-	0.10	-	-	0.004
H	10.10	-	10.50	0.398	-	0.413
h	-	-	0.40	-	-	0.016
k	0	-	8 degrees	0	-	8 degrees
L	0.60	-	1.00	0.024	-	0.039
M	-	4.30	-	-	0.169	-
N	-	-	10 degrees	-	-	10 degrees
O	-	1.20	-	-	0.047	-
Q	-	0.80	-	-	0.031	-
S	-	2.90	-	-	0.114	-
T	-	3.65	-	-	0.144	-
U	-	1.00	-	-	0.039	-
X	4.10	-	4.70	0.161	-	0.185
Y	6.50	-	7.10	0.256	-	0.280

In order to meet environmental requirements, ST offers these devices in different grades of ECOPACK[®] packages, depending on their level of environmental compliance. ECOPACK[®] specifications, grade definitions and product status are available at: www.st.com. ECOPACK[®] is an ST trademark.

6 Applications information

6.1 Applications circuit

Figure 21. Applications circuit for class-D amplifier

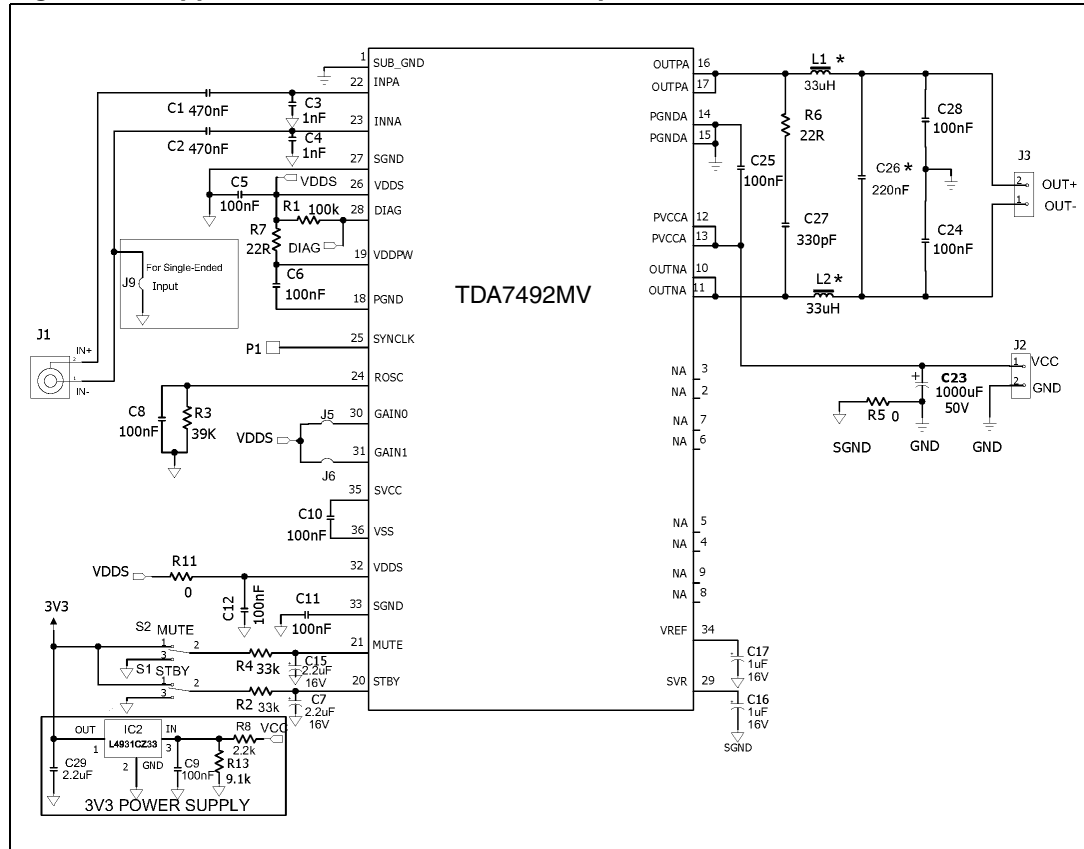

6.2 Mode selection

The three operating modes of the TDA7492MV are set by the two inputs STBY (pin 20) and MUTE (pin 21).

- Standby mode: all circuits are turned off, very low current consumption.
- Mute mode: inputs are connected to ground and the positive and negative PWM outputs are at 50% duty cycle.
- Play mode: the amplifiers are active.

The protection functions of the TDA7492MV are realized by pulling down the voltages of the STBY and MUTE inputs shown in [Figure 22](#). The input current of the corresponding pins must be limited to 200 μ A.

Table 7. Mode settings

Mode Selection	STBY	MUTE
Standby	L ⁽¹⁾	X (don't care)
Mute	H ⁽¹⁾	L
Play	H	H

1. Drive levels defined in [Table 5: Electrical specifications on page 8](#)

Figure 22. Standby and mute circuits

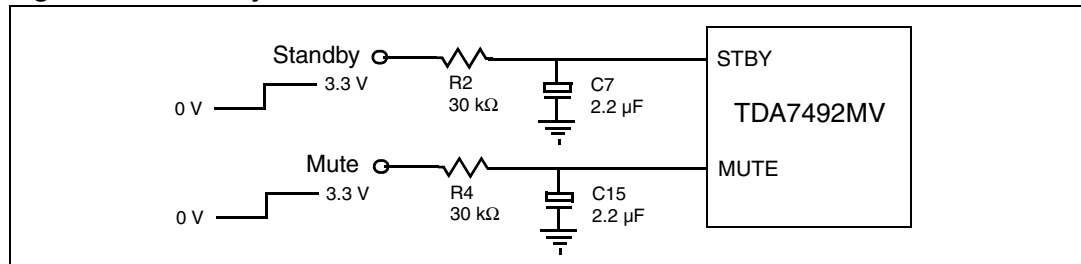
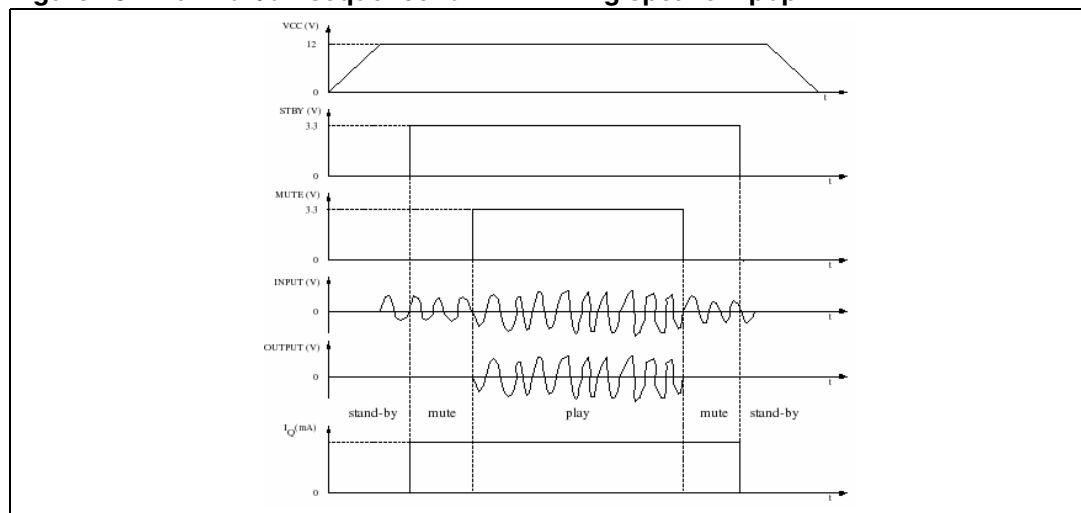

Figure 23. Turn-on/off sequence for minimizing speaker “pop”



6.3 Gain setting

The gain of the TDA7492MV is set by the two inputs, GAIN0 (pin 30) and GAIN1 (pin 31). Internally, the gain is set by changing the feedback resistors of the amplifier.

Table 8. Gain settings

GAIN0	GAIN1	Nominal gain, G_v (dB)
L	L	21.6
L	H	27.6
H	L	31.1
H	H	33.6

6.4 Input resistance and capacitance

The input impedance is set by an internal resistor $R_i = 60\text{ k}\Omega$ (typical). An input capacitor (C_i) is required to couple the AC input signal.

The equivalent circuit and frequency response of the input components are shown in [Figure 24](#). For $C_i = 470\text{ nF}$ the high-pass filter cut-off frequency is below 20 Hz:

$$f_c = 1 / (2 * \pi * R_i * C_i)$$

Figure 24. Device input circuit and frequency response

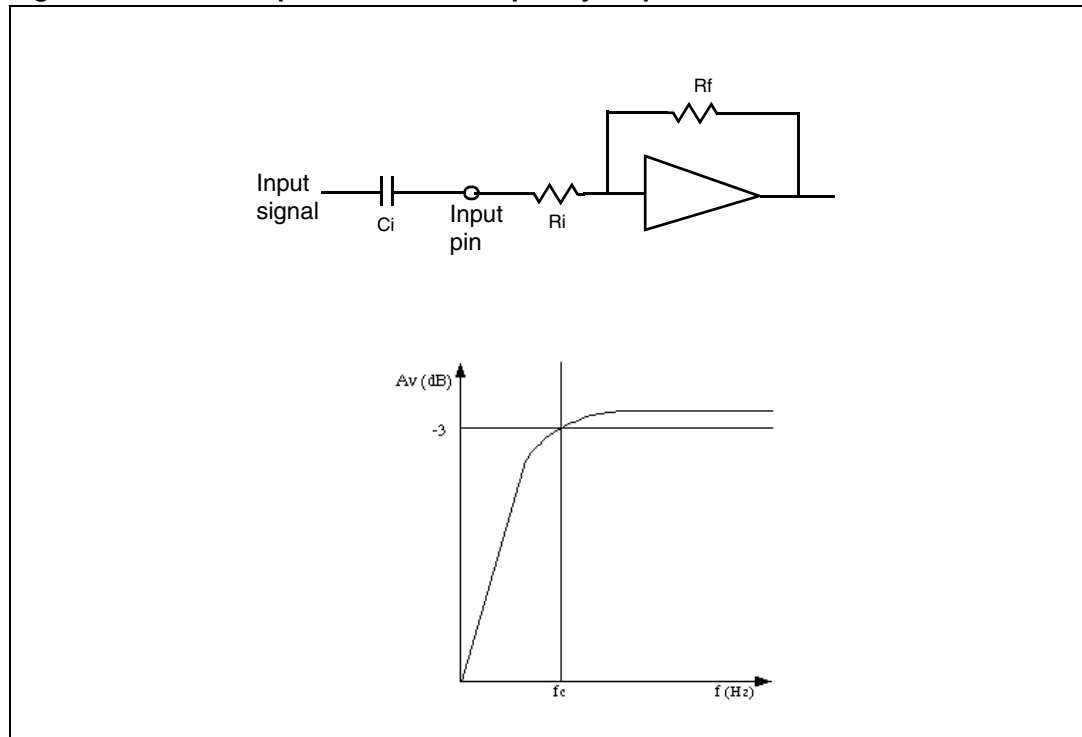

6.5 Internal and external clocks

The clock of the class-D amplifier can be generated internally or can be driven by an external source.

If two or more class-D amplifiers are used in the same system, it is recommended that all devices operate at the same clock frequency. This can be implemented by using one TDA7492MV as master clock, while the other devices are in slave mode (that is, externally clocked). The clock interconnect is via pin SYNCLK of each device. As explained below, SYNCLK is an output in master mode and an input in slave mode.

6.5.1 Master mode (internal clock)

Using the internal oscillator, the output switching frequency, f_{SW} , is controlled by the resistor, R_{OSC} , connected to pin ROSC:

$$f_{SW} = 10^6 / ((16 * R_{OSC} + 182) * 4) \text{ kHz}$$

where R_{OSC} is in $k\Omega$.

In master mode, pin SYNCLK is used as a clock output pin, whose frequency is:

$$f_{SYNCLK} = 2 * f_{SW}$$

For master mode to operate correctly then resistor R_{OSC} must be less than 60 $k\Omega$ as given below in [Table 9](#).

6.5.2 Slave mode (external clock)

In order to accept an external clock input the pin ROSC must be left open, that is, floating. This forces pin SYNCLK to be internally configured as an input as given in [Table 9](#).

The output switching frequency of the slave devices is:

$$f_{SW} = f_{SYNCLK} / 2$$

Table 9. How to set up SYNCLK

Mode	ROSC	SYNCLK
Master	$R_{OSC} < 60 \text{ k}\Omega$	Output
Slave	Floating (not connected)	Input

Figure 25. Master and slave connection

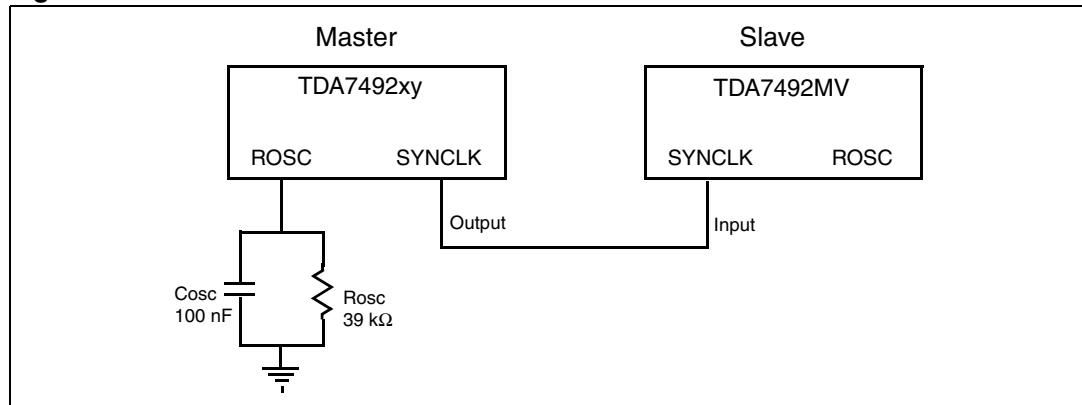

6.6 Output low-pass filter

To avoid EMI problems, it may be necessary to use a low-pass filter before the speaker. The cutoff frequency should be larger than 22 kHz and much lower than the output switching frequency. It is necessary to choose the L-C component values depending on the loud speaker impedance. Some typical values, which give a cut-off frequency of 27 kHz, are shown in [Figure 26](#) and [Figure 27](#) below.

Figure 26. Typical LC filter for a 8-Ω speaker

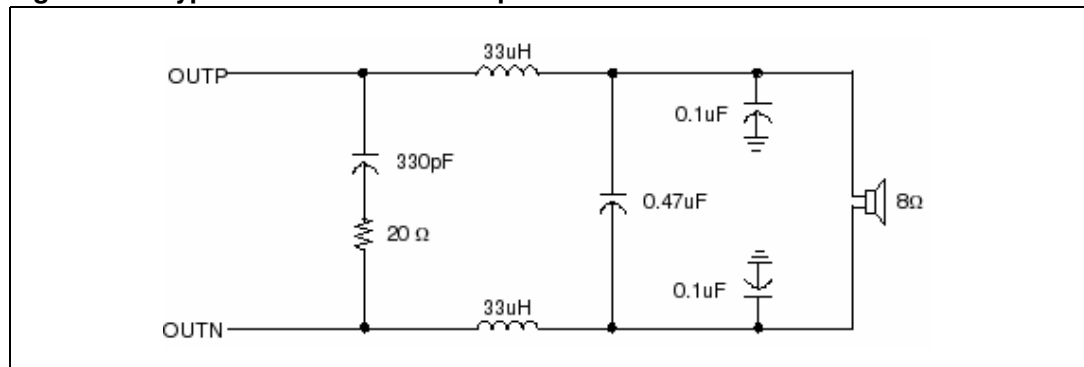
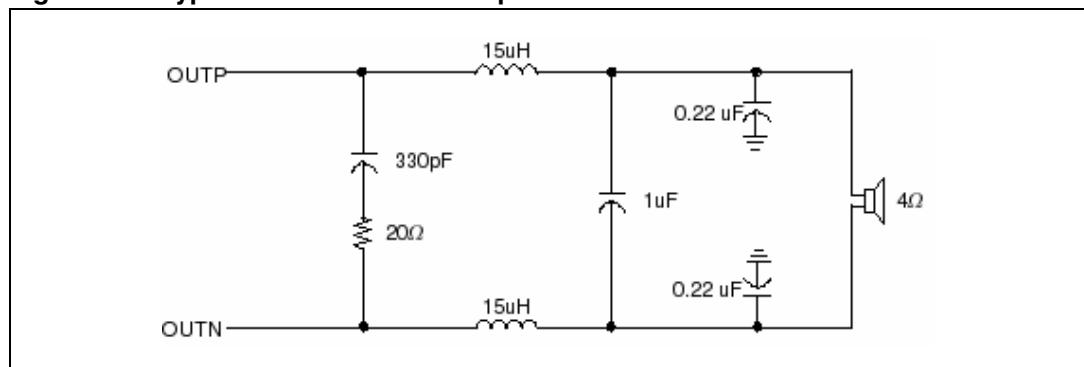

Figure 27. Typical LC filter for a 4-Ω speaker



6.7 Protection function

The TDA7492MV is fully protected against overvoltages, undervoltages, overcurrents and thermal overloads as explained here.

Overvoltage protection (OVP)

If the supply voltage exceeds the value for V_{OVP} given in [Table 5: Electrical specifications on page 8](#) the overvoltage protection is activated which forces the outputs to the high-impedance state. When the supply voltage falls back to within the operating range the device restarts.

Undervoltage protection (UVP)

If the supply voltage drops below the value for V_{UVP} given in [Table 5: Electrical specifications on page 8](#) the undervoltage protection is activated which forces the outputs to

the high-impedance state. When the supply voltage recovers to within the operating range the device restarts.

Overcurrent protection (OCP)

If the output current exceeds the value for I_{OCP} given in [Table 5: Electrical specifications on page 8](#) the overcurrent protection is activated which forces the outputs to the high-impedance state. Periodically, the device attempts to restart. If the overcurrent condition is still present then the OCP remains active. The restart time, T_{OC} , is determined by the R-C components connected to pin STBY.

Thermal protection (OTP)

If the junction temperature, T_j , reaches 145 °C (nominal), the device goes to mute mode and the positive and negative PWM outputs are forced to 50% duty cycle. If the junction temperature exceeds the value for T_j given in [Table 5: Electrical specifications on page 8](#) the device shuts down and the output is forced to the high impedance state. When the device cools sufficiently the device restarts.

6.8 Diagnostic output

The output pin DIAG is an open drain transistor. When the protection is activated it is in the high-impedance state. The pin can be connected to a power supply (< 26 V) by a pull-up resistor whose value is limited by the maximum sinking current (200 μ A) of the pin.

Figure 28. Behavior of pin DIAG for various protection conditions

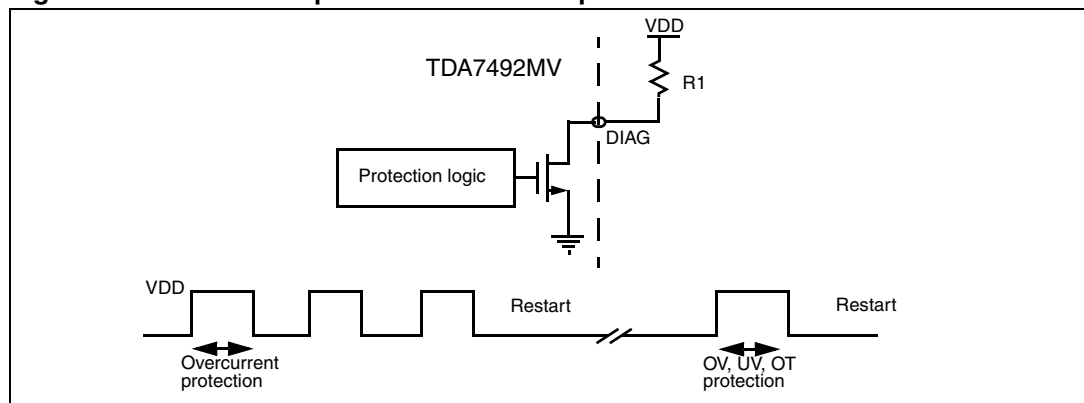

7 Revision history

Table 10. Document revision history

Date	Revision	Changes
20-Oct-2009	1	Initial release.

Please Read Carefully:

Information in this document is provided solely in connection with ST products. STMicroelectronics NV and its subsidiaries ("ST") reserve the right to make changes, corrections, modifications or improvements, to this document, and the products and services described herein at any time, without notice.

All ST products are sold pursuant to ST's terms and conditions of sale.

Purchasers are solely responsible for the choice, selection and use of the ST products and services described herein, and ST assumes no liability whatsoever relating to the choice, selection or use of the ST products and services described herein.

No license, express or implied, by estoppel or otherwise, to any intellectual property rights is granted under this document. If any part of this document refers to any third party products or services it shall not be deemed a license grant by ST for the use of such third party products or services, or any intellectual property contained therein or considered as a warranty covering the use in any manner whatsoever of such third party products or services or any intellectual property contained therein.

UNLESS OTHERWISE SET FORTH IN ST'S TERMS AND CONDITIONS OF SALE ST DISCLAIMS ANY EXPRESS OR IMPLIED WARRANTY WITH RESPECT TO THE USE AND/OR SALE OF ST PRODUCTS INCLUDING WITHOUT LIMITATION IMPLIED WARRANTIES OF MERCHANTABILITY, FITNESS FOR A PARTICULAR PURPOSE (AND THEIR EQUIVALENTS UNDER THE LAWS OF ANY JURISDICTION), OR INFRINGEMENT OF ANY PATENT, COPYRIGHT OR OTHER INTELLECTUAL PROPERTY RIGHT.

UNLESS EXPRESSLY APPROVED IN WRITING BY AN AUTHORIZED ST REPRESENTATIVE, ST PRODUCTS ARE NOT RECOMMENDED, AUTHORIZED OR WARRANTED FOR USE IN MILITARY, AIR CRAFT, SPACE, LIFE SAVING, OR LIFE SUSTAINING APPLICATIONS, NOR IN PRODUCTS OR SYSTEMS WHERE FAILURE OR MALFUNCTION MAY RESULT IN PERSONAL INJURY, DEATH, OR SEVERE PROPERTY OR ENVIRONMENTAL DAMAGE. ST PRODUCTS WHICH ARE NOT SPECIFIED AS "AUTOMOTIVE GRADE" MAY ONLY BE USED IN AUTOMOTIVE APPLICATIONS AT USER'S OWN RISK.

Resale of ST products with provisions different from the statements and/or technical features set forth in this document shall immediately void any warranty granted by ST for the ST product or service described herein and shall not create or extend in any manner whatsoever, any liability of ST.

ST and the ST logo are trademarks or registered trademarks of ST in various countries.

Information in this document supersedes and replaces all information previously supplied.

The ST logo is a registered trademark of STMicroelectronics. All other names are the property of their respective owners.

© 2009 STMicroelectronics - All rights reserved

STMicroelectronics group of companies

Australia - Belgium - Brazil - Canada - China - Czech Republic - Finland - France - Germany - Hong Kong - India - Israel - Italy - Japan - Malaysia - Malta - Morocco - Philippines - Singapore - Spain - Sweden - Switzerland - United Kingdom - United States of America

www.st.com